

VOLTAGE RANGE: 200 - 1000V

CURRENT: 0.5 A

Features

- Low leakage
- Low forward voltage drop
- High current capability
- Easily cleaned with Freon, Alcohol, Isopropanol and similar solvents
- The plastic material carries U/L recognition 94V-0

Mechanical Data

- Case: DO - 4 1
- Terminals: Plated Leads Solderable per MIL-STD-202, Method 208
- Polarity: Cathode Band
- Weight: 0.35 grams (approx.)
- Mounting Position: Any
- Marking: Type Number

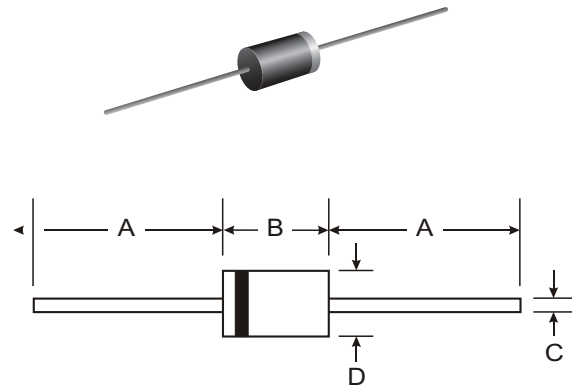

DO-41		
Dim	Min	Max
A	25.40	—
B	4.06	5.21
C	0.71	0.864
D	2.00	2.72
All Dimensions in mm		

Maximum Ratings and Electrical Characteristics T_A = 25°C unless otherwise specified

Single phase, half wave, 60Hz, resistive or inductive load. For capacitive load, derate current by 20%.

Characteristic	Symbol	ERA22-02	ERA22-04	ERA22-06	ERA22-08	ERA22-10	Unit
Maximum recurrent peak reverse voltage	V_{RRM}	200	400	600	800	1000	V
Maximum RMS voltage	V_{RMS}	140	280	420	560	700	V
Maximum DC blocking voltage	V_{DC}	200	400	600	800	1000	V
Maximum average forward rectified current 9.5mm lead length, @ T _A =75°C	$I_{F(AV)}$	0.5					A
Peak forward surge current 8.3ms single half-sine-wave superimposed on rated load @ T _J =125°C	I_{FSM}	20.0					A
Maximum instantaneous forward voltage @ 0.5 A	V_F	1.3					V
Maximum reverse current @ T _A =25°C at rated DC blocking voltage @ T _A =100°C	I_R	5.0 100.0					μ A
Maximum reverse recovery time (Note1)	t_{rr}	400					ns
Typical junction capacitance (Note2)	C_J	12					pF
Typical thermal resistance (Note3)	$R_{\theta JA}$	55					°C/W
Operating junction temperature range	T_J	-55----+150					°C
Storage temperature range	T_{STG}	-55----+150					°C

NOTE: 1. Measured with $I_F=0.5A$, $I_R=1A$, $I_{rr}=0.25A$.

2. Measured at 1.0MHz and applied reverse voltage of 4.0V DC.

3. Thermal resistance from junction to ambient.

FIG.1 – REVERSE RECOVERY TIME CHARACTERISTIC AND TEST CIRCUIT DIAGRAM

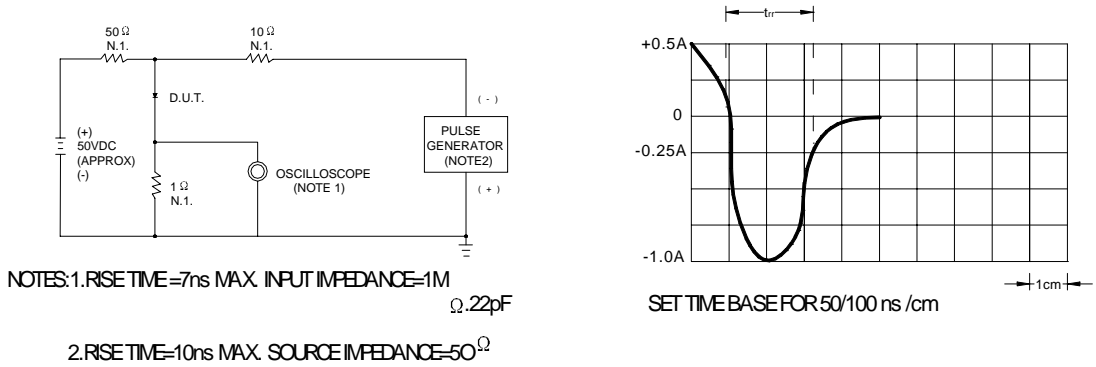
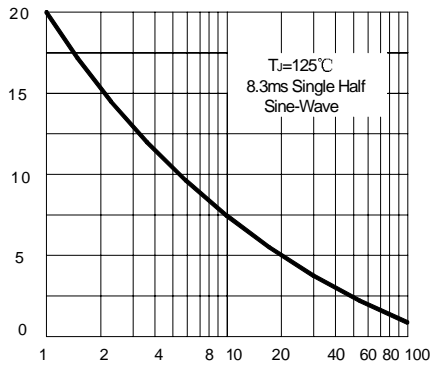

FIG.2- PEAK FORWARD SURGE CURRENT

PEAK FORWARD SURGE CURRENT
AMPERES



NUMBER OF CYCLES AT 60 Hz

FIG.3- FORWARD DERATING CURVE

AVERAGE FORWARD RECTIFIED CURF
CURRENT, AMPERES

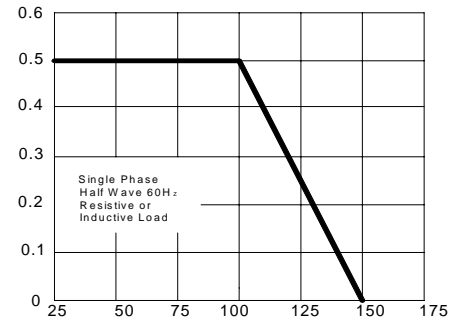

AMBIENT TEMPERATURE, °C

FIG.4 – CURRENT DERATING CURVE

INSTANTANEOUS FORWARD CURRENT
AMPERES

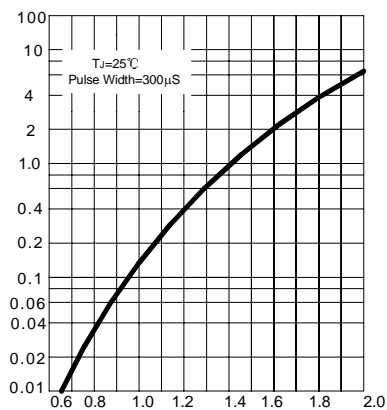

INSTANTANEOUS FORWARD VOLTAGE, VOLTS

FIG.5-TYPECAL JUNCTION CAPACITANCE

JUNCTION CAPACITANCE, pF

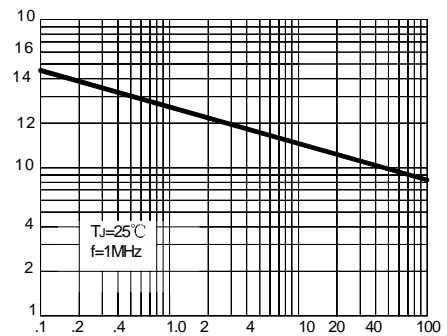

INSTANEOUS FORWARD VOLTAGE, VOLTS