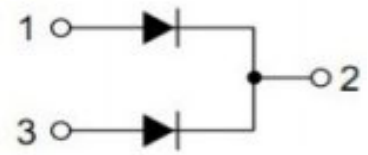
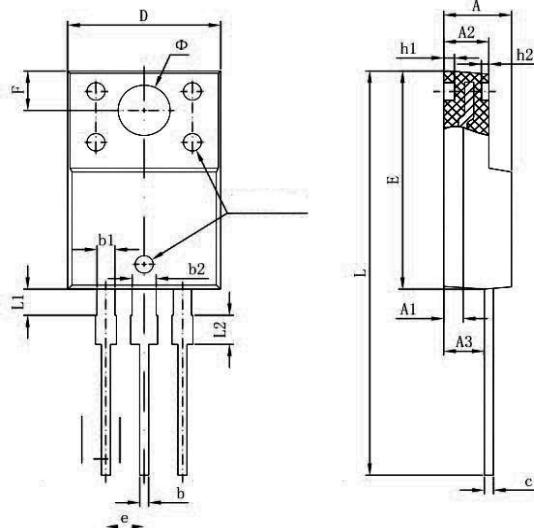

Features

- Schottky Barrier Diodes
- 10 A Total (5A Per Diode Leg)
- Guard Ring for Stress Protection
- Low Forward Voltage
- 175°C Operating Junction Temperature
- Epoxy Meets UL 94 V 0 @ 0.125 in
- Low Power Loss/High Efficiency
- High Surge Capacity
- Low Stored Charge Majority Carrier Conduction
- Pb Free Packages are Available*

Mechanical Characteristics:

- Case: Epoxy, Molded
- Weight: 2.26 grams (approximately)
- Finish: All External Surfaces Corrosion Resistant and Terminal Leads are Readily Solderable
- Lead Temperature for Soldering Purposes: 260°C Max. for 10 Seconds

TO-220F-3L PACKAGE OUTLINE DIMENSIONS

Symbol	Dimensions In Millimeters	
	Min.	Max.
A	4.470	4.670
A1	2.520	2.820
b	0.710	0.910
b1	1.170	1.370
c	0.310	0.530
c1	1.170	1.370
D	10.010	10.310
E	8.500	8.900
E1	12.060	12.460
e	2.540 TYP.	
e1	4.980	5.180
F	2.590	2.890
h	0.000	0.300
L	13.400	13.800
L1	3.560	3.960
Φ	3.735	3.935

RATINGS (Per Diode Leg)

Rating	Symbol	MBRF 10150CT	Unit
Peak Repetitive Reverse Voltage	V_{RRM}	150	V
Average Rectified Forward Current (Rated V_R) $T_C = 133^\circ\text{C}$	$I_{F(AV)}$	5	A
Peak Repetitive Forward Current (Rated V_R , Square Wave, 20 kHz) $T_C = 133^\circ\text{C}$	I_{FRM}	10	A
Maximum Instantaneous Forward Voltage ($I_F = 5\text{Amps}$, $T_C = 25^\circ\text{C}$)	V_F	0.90	V
Nonrepetitive Peak Surge Current (Surge applied at rates load conditions halfwave, single phase, 60Hz)	I_{FSM}	150	A
Peak Repetitive Reverse Surge Current (2.0 μs , 1.0 kHz)	I_{RRM}	5	A
Operating Junction Temperature	T_J	- 65 to +175	$^\circ\text{C}$
Voltage Rate of Change (Rated V_R)	dv/dt	10,000	V/ μs
Maximum Instantaneous Reverse Current (Rated dc Voltage, $T_C = 125^\circ\text{C}$)	I_R	6.0	mA
(Rated dc Voltage, $T_C = 25^\circ\text{C}$)		0.05	

MBRF10150CT

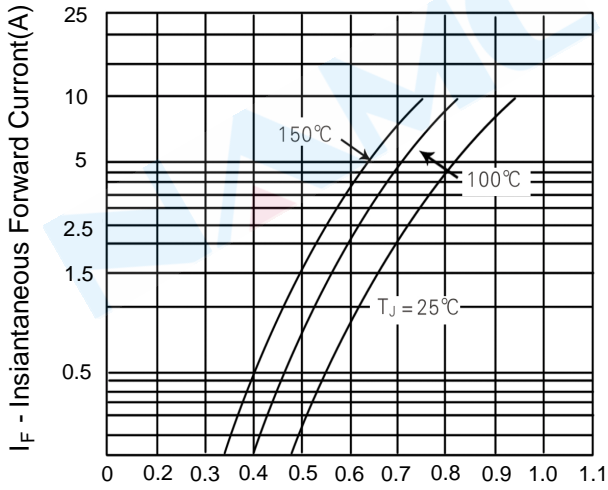

Figure 1. Typical Forward Voltage Per Diode

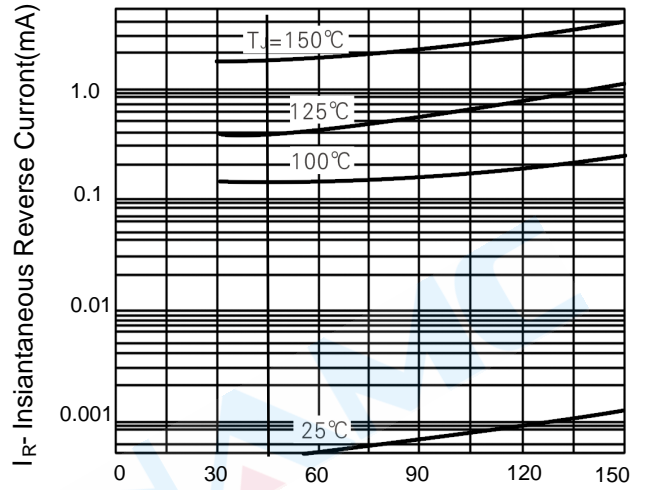

Figure 2. Typical Reverse Current Per Diode

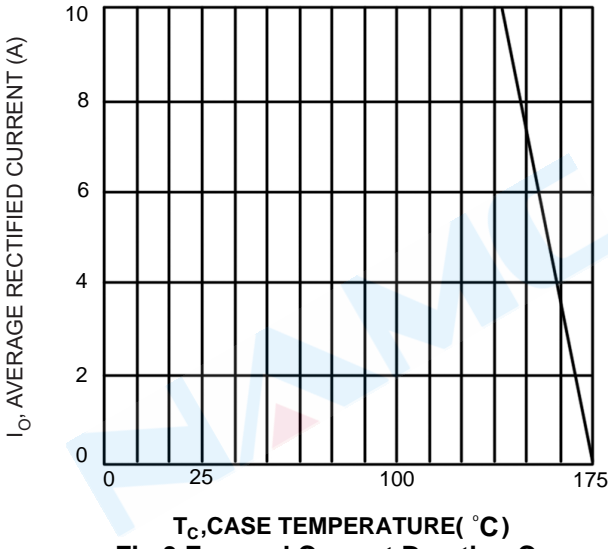

Fig.3 Forward Current Derating Curve

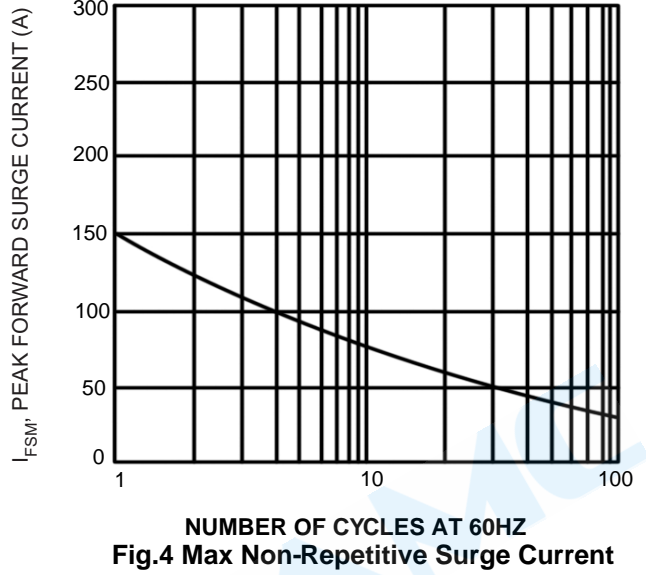

Fig.4 Max Non-Repetitive Surge Current