

TPD1S514x Family USB Charger Over Voltage, Surge and ESD Protection for V_{BUS} PIN

1 Features

- Over Voltage Protection at V_{BUS_CON} up to 30-V DC
- Precision OVP ($< \pm 1\%$ Tolerance)
- Low R_{ON} nFET Switch Supports Host and Charging Mode
- Dedicated V_{BUS_POWER} Pin Offers Flexible Power up Options Under Dead Battery Condition
- Transient Protection for V_{BUS} Line:
 - IEC 61000-4-2 Contact Discharge ± 15 kV
 - IEC 61000-4-2 Air Gap Discharge ± 15 kV
 - IEC 61000-4-5 Open Circuit Voltage 100 V
 - Precision Clamp Circuit Limits the V_{BUS_SYS} Voltage $< V_{OVP}$
- USB Inrush Current Compliant
- Thermal Shutdown (TSD) Feature

2 Applications

- Cell Phones
- Tablets
- eBook
- Portable Media Players
- 5-V, 9-V, and 12-V Power Rails

3 Description

The TPD1S514 Family consists of single-chip protection solutions for 5-V, 9-V or 12-V USB V_{BUS} lines, or other power buses. The bidirectional nFET switch ensures safe current flow in both charging and host mode while protecting the internal system circuits from any over voltage condition at the V_{BUS_CON} pin. On the V_{BUS_CON} pin, this device can handle over voltage protection up to 30-V DC. After the \overline{EN} pin toggles low, any device in the TPD1S514 Family waits 20 ms before turning ON the nFET through a soft start delay.

Typical application interfaces for the TPD1S514 Family are V_{BUS} lines in USB connectors typically found in cell phones, tablets, eBooks, and portable media players. The TPD1S514 Family can also be applied to any system using an interface for a 5-V, 9-V, or 12-V power rail.

Device Information⁽¹⁾

DEVICE NAME	PACKAGE	BODY SIZE (NOM)
TPD1S514x	WCSP (12)	1.29 mm x 1.99 mm

(1) For all available packages, see the orderable addendum at the end of the datasheet.

TPD1S514 Family Circuit Protection Scheme

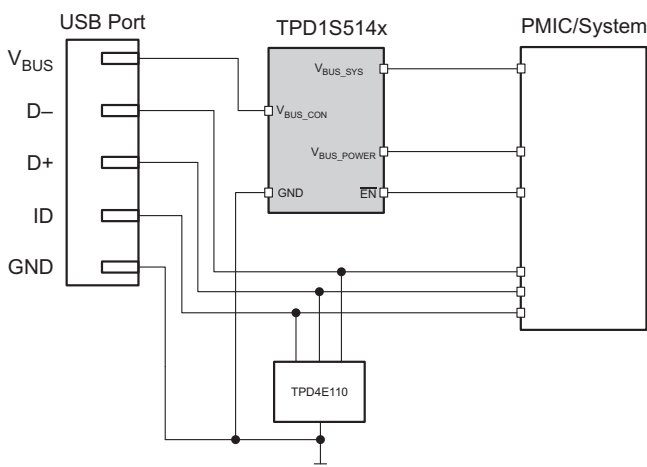

TPD1S514 Family Block Diagram

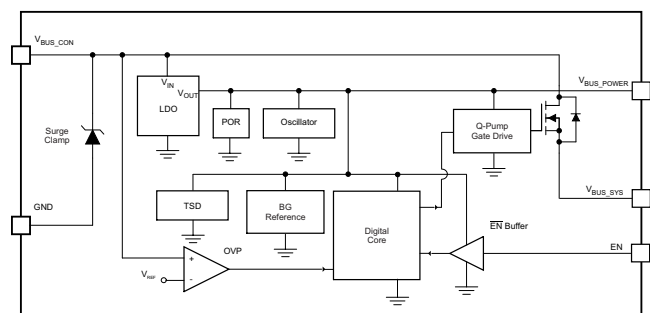

Table of Contents

1 Features	1	8 Detailed Description	11
2 Applications	1	8.1 Overview	11
3 Description	1	8.2 Functional Block Diagram	11
4 Revision History	2	8.3 Feature Description	11
5 Device Comparison Table	3	8.4 Device Functional Modes	13
6 Pin Configuration and Functions	3	9 Application and Implementation	14
7 Specifications	4	9.1 Application Information	14
7.1 Absolute Maximum Ratings	4	9.2 Typical Application	14
7.2 ESD Ratings	4	10 Power Supply Recommendations	18
7.3 Recommended Operating Conditions	5	11 Layout	19
7.4 Thermal Information	5	11.1 Layout Guidelines	19
7.5 Supply Current Consumption	5	11.2 Layout Example	19
7.6 Electrical Characteristics \overline{EN} Pin	6	12 Device and Documentation Support	20
7.7 Thermal Shutdown Feature	6	12.1 Community Resources	20
7.8 Electrical Characteristics nFET Switch	6	12.2 Trademarks	20
7.9 Electrical Characteristics OVP Circuit	7	12.3 Electrostatic Discharge Caution	20
7.10 Electrical Characteristics V_{BUS_POWER} Circuit	7	12.4 Glossary	20
7.11 Timing Requirements	8	13 Mechanical, Packaging, and Orderable Information	20
7.12 TPD1S514-1 Typical Characteristics	9		

4 Revision History

NOTE: Page numbers for previous revisions may differ from page numbers in the current version.

Changes from Revision D (July 2015) to Revision E	Page
• Removed Preview status of TPD1S514-3	1
• Changed Max value of $I_{V_{BUS_SLEEP}}$ PARAMETER for TPD1S514-3 (Preview) from 308 μ A to 335 μ A.	5
• Updated TEST CONDITIONS for T_{OFF_DELAY} PARAMETER.	8

Changes from Revision C (July 2015) to Revision D	Page
• Added TPD1S514 and TPD1S514-3 (Preview)	1

Changes from Revision B (September 2014) to Revision C	Page
• Removed Previewed TPD1S514-3 and Programmability Features.	1

Changes from Revision A (July 2014) to Revision B	Page
• Changed Body size to fix rounding error.	1

Changes from Original (April 2014) to Revision A	Page
• Removed Preview status of TPD1S514-2.	1
• Updated Device Comparison table.	3
• Updated Electrical Characteristics OVP Circuit table	7

5 Device Comparison Table

TPD1S514 Family	V _{OVp} (V)			V _{OVp, HYS} (mV)	V _{BUS_POWER} (V) ⁽¹⁾		T_Startup delay (ms) options	T_Soft Start (ms) options
	Min	Typ	Max	Typ	Min	Typ	Typ	Typ
TPD1S514-1	5.9	5.95	5.99	100	4.7	4.95	20	3.5
TPD1S514-2	9.9	9.98	10.05	100	4.7	4.95		
TPD1S514-3	13.5	13.75	14	100	4.7	4.95		
TPD1S514	5.9	5.95	5.99	20	6.2	6.48		

(1) With V_{BUS_CON} > 6.5V. See Sections [V_{BUS_POWER}](#), [TPD1S514-1](#), [TPD1S514-2](#), [TPD1S514-3](#) and [V_{BUS_POWER}](#), [TPD1S514](#) for full description.

6 Pin Configuration and Functions

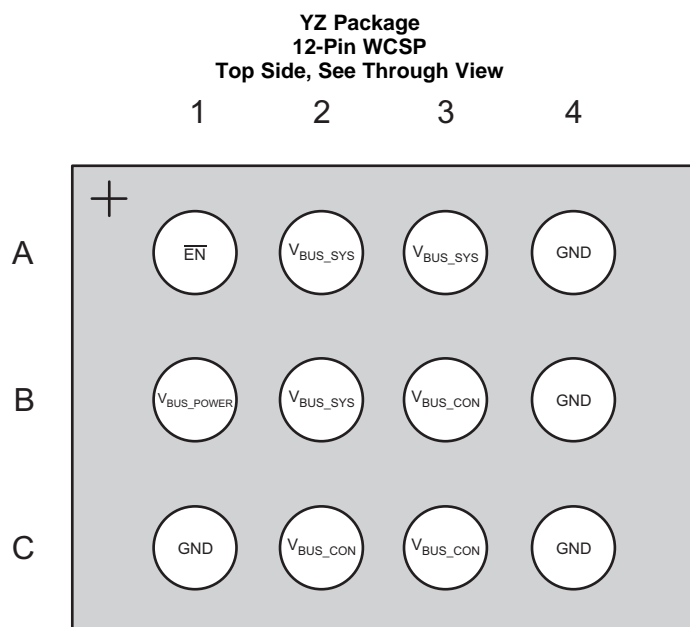

Pin Functions

PIN		I/O	DESCRIPTION
NAME	NO.		
$\overline{\text{EN}}$	A1	I	Enable Active-Low Input. Drive $\overline{\text{EN}}$ low to enable the switch. Drive $\overline{\text{EN}}$ high to disable the switch.
V _{BUS_POWER}	B1	O	5-V Power source controlled by V _{BUS_CON} .
V _{BUS_SYS}	A2, A3, B2	IO	Connect to internal VBUS plane.
V _{BUS_CON}	B3, C2, C3	IO	Connect to USB connector VBUS pin; IEC 61000-4-2 ESD protection and IEC 61000-4-5 Surge protection.
GND	A4, B4, C1, C4	G	Connect to PCB ground plane.

7 Specifications

7.1 Absolute Maximum Ratings⁽¹⁾⁽²⁾

over operating free-air temperature range (unless otherwise noted)

		MIN	MAX	UNIT	
V _{BUS_CON}	Supply voltage from USB connector	-0.3	30	V	
V _{BUS_SYS}	Internal Supply DC voltage Rail on the PCB	-0.3	20	V	
I _{BUS}	Continuous input current on V _{BUS_CON} pin ⁽³⁾		3.5	A	
I _{OUT}	Continuous output current on V _{BUS_CON} pin ⁽³⁾		3.5	A	
I _{PEAK}	Peak Input and Output Current on V _{BUS_CON} , V _{BUS_SYS} pin (10 ms)		8	A	
I _{DIODE}	Continuous forward current through the FET body diode		1	A	
I _{POWER}	Continuous Current through V _{BUS_POWER}		1	mA	
V _{EN}	Voltage on Input pin (\overline{EN})		7	V	
V _{BUS_POWER}	Continuous Voltage at V _{BUS_POWER}	TPD1S514-1	See ⁽⁴⁾	V	
		TPD1S514-2	See ⁽⁴⁾		
		TPD1S514-3	See ⁽⁴⁾		
		TPD1S514	See ⁽⁴⁾		
T _{STG}	Storage temperature range	-65	150	°C	
T _A	Operating Free Air Temperature	-40	85	°C	
	IEC 61000-4-5 Peak Pulse Current (t _p = 8/20μs)	V _{BUS_CON} pin	30	A	
	IEC 61000-4-5 Peak Pulse Power (t _p = 8/20μs)	V _{BUS_CON} pin	900	W	
	IEC 61000-4-5 Open circuit voltage (t _p = 1.2/50 μs)	V _{BUS_CON} pin	100	V	
C _{LOAD}	Output load capacitance	V _{BUS_SYS} pin	0.1	100	μF
C _{CON}	Input capacitance	V _{BUS_CON} pin	0.1	50	μF
C _{POW}	V _{BUS_POWER} Capacitance	V _{BUS_POWER} pin	0.1	4.7	μF

- (1) Stresses above these ratings may cause permanent damage. Exposure to absolute maximum conditions for extended periods may degrade device reliability. These are stress ratings only, and functional operation of the device at these or any other conditions beyond those specified is not implied.
- (2) The algebraic convention, whereby the most negative value is a minimum and the most positive value is a maximum.
- (3) Thermal limits and power dissipation limits must be observed.
- (4) 6.9 V or V_{BUS_CON} + 0.3 V, whichever is smaller.

7.2 ESD Ratings

			VALUE	UNIT	
V _(ESD)	Electrostatic discharge	Human-body model (HBM), per ANSI/ESDA/JEDEC JS-001 ⁽¹⁾	±2000	V	
		Charged-device model (CDM), per JEDEC specification JESD22-C101 ⁽²⁾	±500		
		IEC 61000-4-2 Contact Discharge	V _{BUS_CON} pin		±15000
		IEC 61000-4-2 Air-gap Discharge	V _{BUS_CON} pin		±15000

- (1) JEDEC document JEP155 states that 500-V HBM allows safe manufacturing with a standard ESD control process. Manufacturing with less than 500-V HBM is possible with the necessary precautions.
- (2) JEDEC document JEP157 states that 250-V CDM allows safe manufacturing with a standard ESD control process. Manufacturing with less than 250-V CDM is possible with the necessary precautions.

7.3 Recommended Operating Conditions

over operating free-air temperature range (unless otherwise noted)

			MIN	TYP	MAX	UNIT
V _{BUS_CON}	Supply voltage from USB connector	TPD1S514-1	3.5	5	5.9	V
		TPD1S514-2	3.5	9	9.9	
		TPD1S514-3	3.5	12	13.5	
		TPD1S514	3.5	5	5.9	
V _{BUS_SYS}	Internal Supply DC voltage Rail on the PCB	TPD1S514-1	3.9	5	5.9	V
		TPD1S514-2	3.9	9	9.9	
		TPD1S514-3	3.9	12	13.5	
		TPD1S514	3.9	5	5.9	
C _{LOAD}	Output load capacitance	V _{BUS_SYS} pin	2.2		μF	
C _{CON}	Input capacitance	V _{BUS_CON} pin	1		μF	
C _{POWER}	Capacitance on V _{BUS_POWER}	V _{BUS_POWER} pin	1		μF	
T _A	Operating free-air temperature		-40		85	°C

7.4 Thermal Information

THERMAL METRIC ⁽¹⁾		TPD1S514 Family	UNIT
		YZ (WCSP)	
		12 PINS	
R _{θJA}	Junction-to-ambient thermal resistance	89	°C/W
R _{θJC(top)}	Junction-to-case (top) thermal resistance	0.6	°C/W
R _{θJB}	Junction-to-board thermal resistance	16.3	°C/W
Ψ _{JT}	Junction-to-top characterization parameter	2.7	°C/W
Ψ _{JB}	Junction-to-board characterization parameter	16.2	°C/W

 (1) For more information about traditional and new thermal metrics, see the *IC Package Thermal Metrics* application report, [SPRA953](#).

7.5 Supply Current Consumption

over operating free-air temperature range (unless otherwise noted)

PARAMETER	TEST CONDITIONS	DEVICE NAME	TYP	MAX	UNIT	
I _{BUS_SLEEP}	Measured at V _{BUS_CON} pin, EN = 5 V	V _{BUS_CON} = 5 V	TPD1S514-1	150	245	μA
		V _{BUS_CON} = 9 V	TPD1S514-2	176	281	
		V _{BUS_CON} = 12 V	TPD1S514-3	195	335	
		V _{BUS_CON} = 5 V	TPD1S514	150	245	
I _{BUS}	Measured at V _{BUS_CON} pin, EN = 0 V and no load	V _{BUS_CON} = 5 V	TPD1S514-1	228	354	μA
		V _{BUS_CON} = 9 V	TPD1S514-2	250	413	
		V _{BUS_CON} = 12 V	TPD1S514-3	270	456	
		V _{BUS_CON} = 5 V	TPD1S514	228	354	
I _{BUS_SYS}	Measured at V _{BUS_SYS} pin, V _{BUS_CON} = Hi-Z, EN = 0 V	V _{BUS_SYS} = 5 V	TPD1S514-1	210	354	μA
		V _{BUS_SYS} = 9 V	TPD1S514-2	250	424	
		V _{BUS_SYS} = 12 V	TPD1S514-3	333	461	
		V _{BUS_SYS} = 5 V	TPD1S514	210	354	
I _{HOST_LEAK}	Measured at V _{BUS_SYS} pin, V _{BUS_CON} = Hi-Z, EN = 5 V	V _{BUS_SYS} = 5 V	TPD1S514-1	90	218	μA
		V _{BUS_SYS} = 9 V	TPD1S514-2	290	491	
		V _{BUS_SYS} = 12 V	TPD1S514-3	506	696	
		V _{BUS_SYS} = 5 V	TPD1S514	90	218	

7.6 Electrical Characteristics $\overline{\text{EN}}$ Pin

over operating free-air temperature range (unless otherwise noted)

PARAMETER			TEST CONDITIONS	MIN	TYP	MAX	UNIT
V_{IH}	High-level input voltage	$\overline{\text{EN}}$	$V_{BUS_CON} = 5\text{ V}$	1.2		6	V
V_{IL}	Low-level input voltage	$\overline{\text{EN}}$	$V_{BUS_CON} = 5\text{ V}$	0		0.8	V
I_{IL}	Input Leakage Current	$\overline{\text{EN}}$	$V_{\overline{\text{EN}}} = 0\text{ V}$, $V_{BUS_CON} = 5\text{ V}$			1	μA
I_{IH}	Input Leakage Current	$\overline{\text{EN}}$	$V_{\overline{\text{EN}}} = 5\text{ V}$, $V_{BUS_CON} = 5\text{ V}$			10	μA

7.7 Thermal Shutdown Feature

over operating free-air temperature range (unless otherwise noted)

PARAMETER		TEST CONDITIONS	MIN	TYP	MAX	UNIT
T_{SHDN}	Thermal Shutdown	$V_{BUS_CON} = 5\text{ V}$, $\overline{\text{EN}} = 0\text{ V}$, Junction temperature decreases from thermal shutdown level until the nFET switch turns off.		145		$^{\circ}\text{C}$
Thermal Shutdown Hysteresis		$V_{BUS_CON} = 5\text{ V}$, $\overline{\text{EN}} = 0\text{ V}$, Junction temperature decreases from thermal shutdown level until the nFET switch turns on.		25		$^{\circ}\text{C}$

7.8 Electrical Characteristics nFET Switch

 $T = 25^{\circ}\text{C}$

PARAMETER		TEST CONDITIONS		MIN	TYP	MAX	UNIT
R_{ON}	Switch ON Resistance	$V_{BUS_CON} = 5\text{ V}$, $I_{OUT} = 1\text{ A}$	TPD1S514-1		39	50	m Ω
		$V_{BUS_CON} = 9\text{ V}$, $I_{OUT} = 1\text{ A}$	TPD1S514-2		39	50	
		$V_{BUS_CON} = 12\text{ V}$, $I_{OUT} = 1\text{ A}$	TPD1S514-3		39	50	
		$V_{BUS_CON} = 5\text{ V}$, $I_{OUT} = 1\text{ A}$	TPD1S514		39	50	

7.9 Electrical Characteristics OVP Circuit

T = 25°C

PARAMETER			TEST CONDITIONS	MIN	TYP	MAX	UNIT	
V _{OVP}	Input voltage protection threshold	V _{BUS_CON}	V _{BUS_CON} increasing from 0 V to 20 V	TPD1S514-1	5.90	5.95	5.99	V
				TPD1S514-2	9.9	9.98	10.05	
				TPD1S514-3	13.5	13.75	14	
				TPD1S514	5.90	5.95	5.99	
V _{HYS_OVP}	Hysteresis on OVP	V _{BUS_CON}	V _{BUS_CON} decreasing from 20 V to 0 V	TPD1S514-1		100	mV	
				TPD1S514-2		100		
				TPD1S514-3		100		
				TPD1S514		20		
V _{UVLO}	Input under voltage lockout	V _{BUS_CON}	V _{BUS_CON} voltage rising from 0 V to 5 V	2.7	3.1	3.5	V	
V _{HYS_UVLO}	Hysteresis on UVLO	V _{BUS_CON}	Difference between rising and falling UVLO thresholds		80		mV	
V _{UVLO_FALLING}	Input under voltage lockout	V _{BUS_CON}	V _{BUS_CON} voltage falling from 5 V to 0 V	2.6	3.0	3.4	V	
V _{UVLO_SYS}	V _{BUS_SYS} under voltage lockout	V _{BUS_SYS}	V _{BUS_SYS} voltage rising from 0 V to 5 V	2.8	3.7	4.3	V	
V _{HYS_UVLO_SYS}	V _{BUS_SYS} UVLO Hysteresis	V _{BUS_SYS}	Difference between rising and falling UVLO thresholds on V _{BUS_SYS}		500		mV	
V _{UVLO_SYS_FALLING}	V _{BUS_SYS} under voltage lockout	V _{BUS_SYS}	V _{BUS_SYS} voltage falling from 5 V to 0 V	2.6	3.0	3.4	V	

7.10 Electrical Characteristics V_{BUS_POWER} Circuit

over operating free-air temperature range (unless otherwise noted)

PARAMETER			TEST CONDITIONS	MIN	TYP	MAX	UNIT
V _{CLAMP}	Output Voltage on V _{BUS_POWER} during OVP	V _{BUS_CON} = 20 V	TPD1S514-1		5.0	5.5	V
			TPD1S514-2		5.0	5.5	
			TPD1S514-3		5.0	5.5	
			TPD1S514		6.48	6.68	
V _{BUS_POWER}	Output Voltage on V _{BUS_POWER} during normal operation	V _{BUS_CON} = 5 V; I _{BUS_POWER} = 1 mA;	TPD1S514-1	4.7	4.95	V	
			TPD1S514-2	4.7	4.95		
			TPD1S514-3	4.7	4.95		
			TPD1S514	4.7	4.98		
I _{BUS_POWER_MAX}	Output Current on V _{BUS_POWER}	V _{BUS_CON} = 5 V – 15 V				3	mA

7.11 Timing Requirements

over operating free-air temperature range (unless otherwise noted)

PARAMETER		TEST CONDITIONS	MIN	TYP	MAX	UNIT	
t_{DELAY}	USB Charging Turn-ON Delay	Measured from \overline{EN} asserted LOW to nFET begins to Turn ON, excludes soft-start time		20		ms	
							TPD1S514-1
							TPD1S514-2
							TPD1S514-3
t_{SS}	USB Charging rise time (Soft Start Delay)	Force 5 V on VBUS_CON, measured from V_{BUS_SYS} rises from 10% to 90% (with 1 M Ω load/ NO C_{LOAD})		3.5		ms	
							TPD1S514-1
							TPD1S514-2
							TPD1S514-3
t_{OFF_DELAY}	USB Charging Turn-OFF time	Measured from \overline{EN} asserted High to V_{BUS_SYS} falling to 10% with $R_{LOAD} = 10 \Omega$ and No C_{LOAD} on V_{BUS_SYS}		5.5		μ s	
							TPD1S514-1
							TPD1S514-2
							TPD1S514-3
OVER VOLTAGE PROTECTION							
$t_{OVP_response}$	OVP Response time	Measured from OVP Condition to FET Turn OFF ⁽¹⁾			100	ns	

(1) Specified by design, not production tested

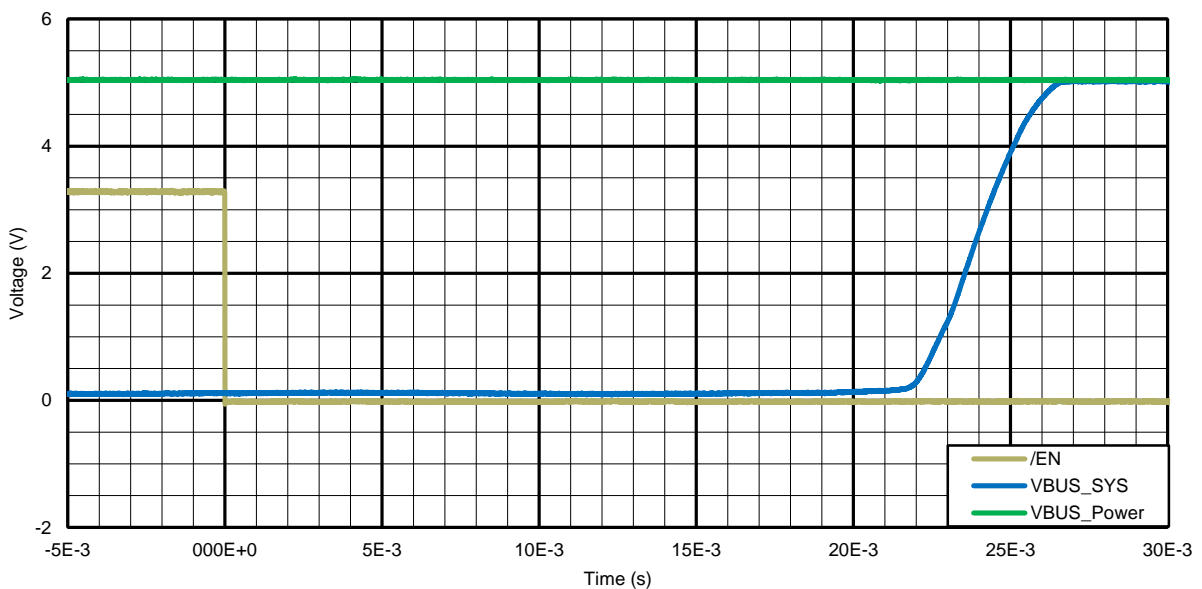
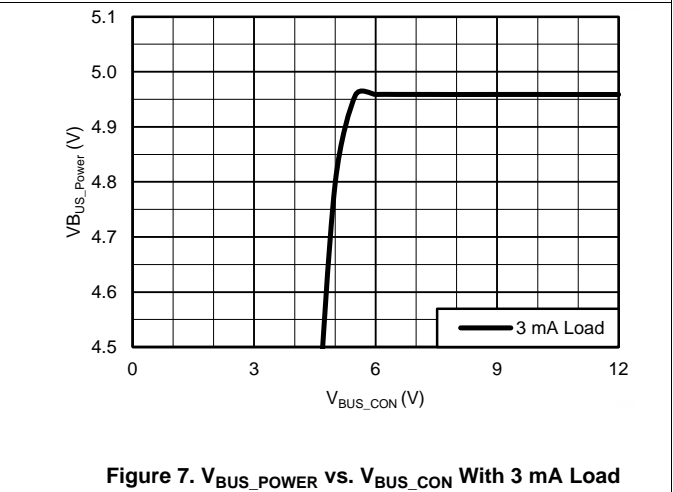
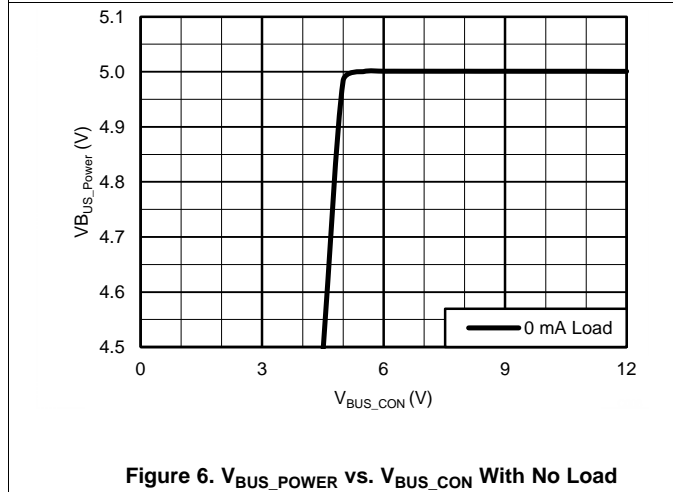
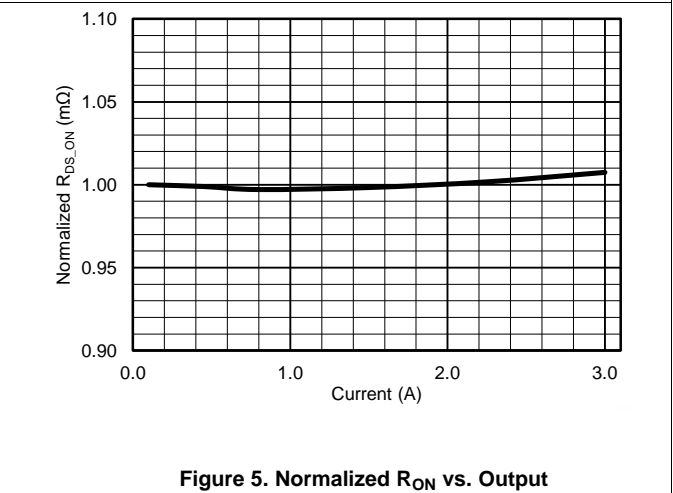
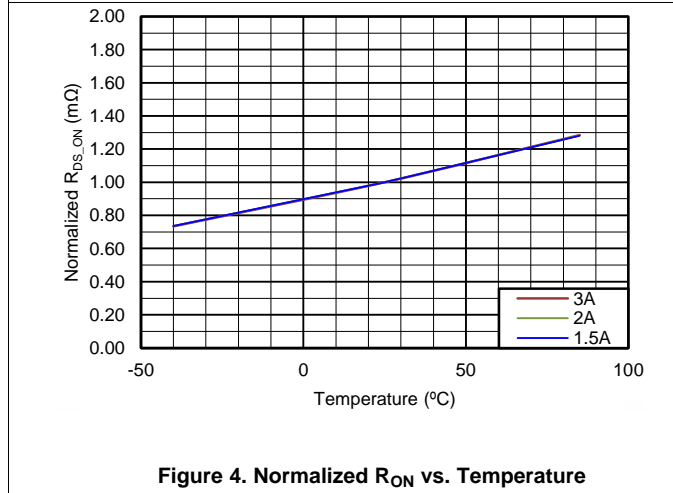
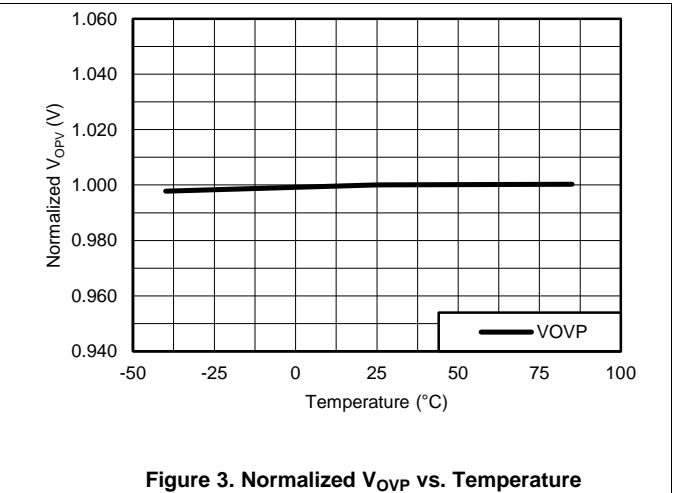
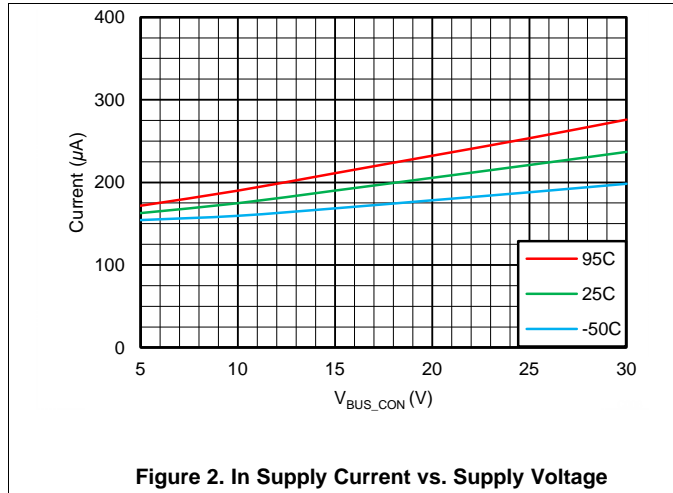
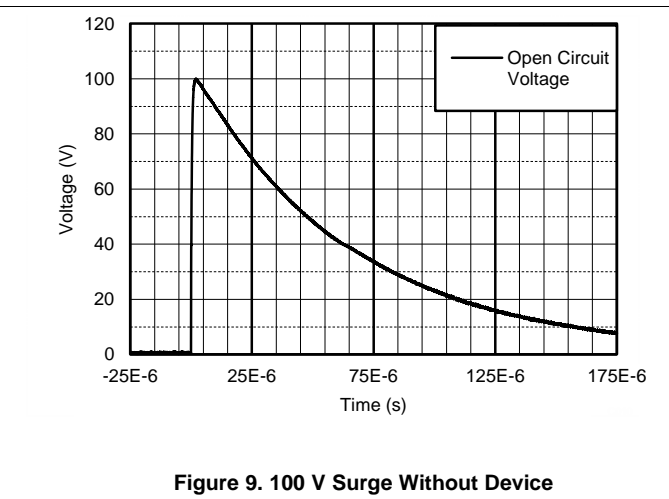
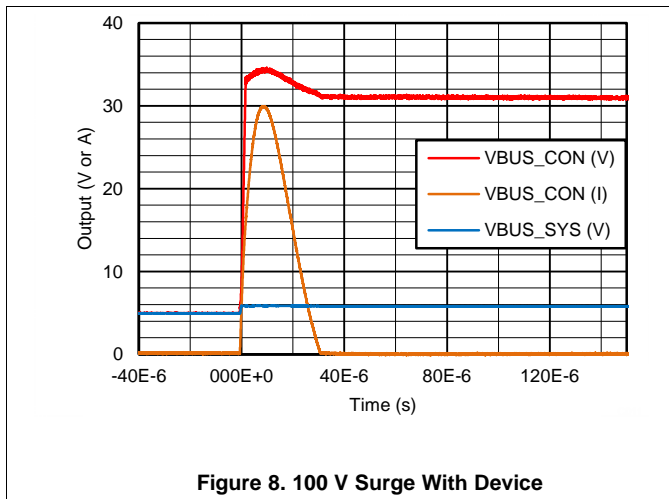

Figure 1. TPD1S514-1 Response to set \overline{EN} low

7.12 TPD1S514-1 Typical Characteristics



TPD1S514-1 Typical Characteristics (continued)



8 Detailed Description

8.1 Overview

The TPD1S514 Family provides single-chip ESD, surge, and over voltage protection solutions for portable USB Charging and Host interfaces. Each device offers over voltage protection at the V_{BUS_CON} pin up to 30-V DC. The TPD1S514 Family offers an ESD and Precision Clamp for the V_{BUS_CON} pin, thus eliminating the need for external TVS clamp circuits in the application.

Each device has an internal oscillator and charge pump which controls turning ON the internal nFET switch. The internal oscillator controls the timers which enable the charge pump. If V_{BUS_CON} is less than V_{OVP} , the internal charge pump is enabled. After a 20 ms internal delay, the charge-pump starts-up, and turns ON the internal nFET switch through a soft start. If at any time V_{BUS_CON} rises above V_{OVP} , the nFET switch is turned OFF within 100 ns.

The TPD1S514 Family of devices also have a V_{BUS_POWER} pin which follows V_{BUS_CON} up to 4.9 V at 3 mA (except for TPD1S514, which follows V_{BUS_CON} up to 6.48 V, after which it is regulated to that voltage) to power the system from V_{BUS_CON} . In the case where the system battery state cannot power the system, voltage from an external charger can be provided to power the system. V_{BUS_POWER} is supplied by an always on LDO regulator supplied by V_{BUS_CON} . V_{BUS_POWER} output voltage remains regulated to 4.9 V (except for TPD1S514, which follows V_{BUS_CON} up to 6.48 V, after which it is regulated to that voltage) at up to 30-V DC on V_{BUS_CON} and during IEC 61000-4-5 surge events of up to 100 V open circuit voltage on V_{BUS_CON} .

8.2 Functional Block Diagram

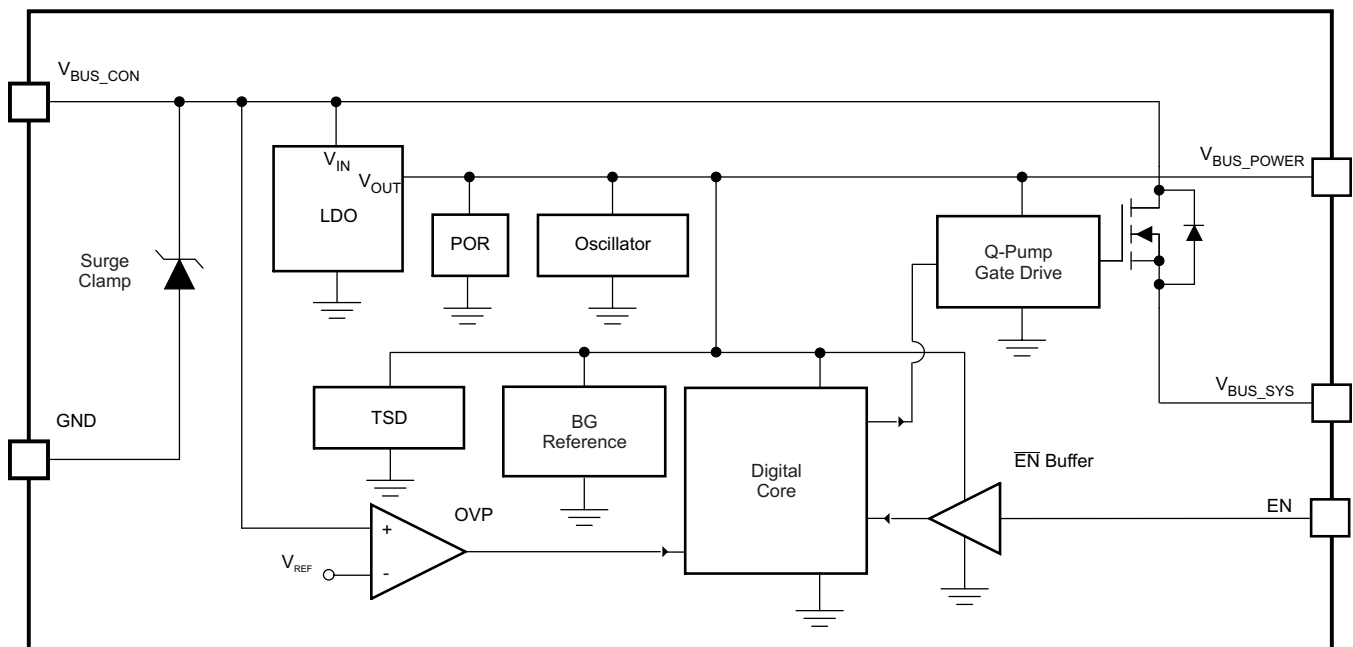

8.3 Feature Description

8.3.1 Over Voltage Protection on V_{BUS_CON} up to 30 V DC

When the V_{BUS_CON} voltage rises above V_{OVP} , the internal nFET switch is turned OFF, removing power from the system side. V_{BUS_CON} can tolerate up to 30-V DC. The response to over voltage is very rapid, with the nFET switch turning off in less than 100 ns. When the V_{BUS_CON} voltage returns back to below $V_{OVP} - V_{HYS_OVP}$, the nFET switch is turned ON again after an internal delay of t_{OVP_RECOV} (t_{DELAY}). This time delay ensures that the V_{BUS_CON} supply has stabilized before turning the switch back on. After t_{OVP_RECOV} , the TPD1S514 Family device turns on the nFET through a soft start. Once the OVP condition is cleared the nFET is turned completely ON.

Feature Description (continued)

8.3.2 Precision OVP (< ±1% Tolerance)

1% OVP trip threshold accuracy allows use of the entire input charging range while protecting sensitive system-side components from over voltage conditions.

8.3.3 Low R_{ON} nFET Switch Supports Host and Charging Mode

The nFET switch has a total on resistance (R_{ON}) of 39 m Ω . This equates to a voltage drop of less than 140 mV when charging at the maximum 3.5 A current level. Such low R_{ON} helps provide maximum potential to the system as provided by an external charger or by the system when in Host Mode.

8.3.4 V_{BUS_POWER} , TPD1S514-1, TPD1S514-2, TPD1S514-3

The V_{BUS_POWER} pin provides up to 3 mA and 5 V for powering the system using V_{BUS_CON} . V_{BUS_POWER} follows V_{BUS_CON} after 3.5 V and up to the regulated 5 V. In the case where the system battery state cannot power the system, voltage from an external charger can power the system. V_{BUS_POWER} is supplied by an always on LDO regulator supplied by V_{BUS_CON} . The V_{BUS_POWER} output voltage remains regulated to 5 V at up to 30-V DC on V_{BUS_CON} and during IEC 61000-4-5 surge events of up to 100 V.

8.3.5 V_{BUS_POWER} , TPD1S514

The V_{BUS_POWER} pin provides up to 3 mA and 6.48 V for powering the system using V_{BUS_CON} . V_{BUS_POWER} follows V_{BUS_CON} after 3.5 V and up to the regulated 6.48 V. In the case where the system battery state cannot power the system, voltage from an external charger can be provided to power the system. V_{BUS_POWER} is supplied by an always on LDO regulator supplied by V_{BUS_CON} . The V_{BUS_POWER} output voltage remains regulated to 6.48 V at up to 30-V DC on V_{BUS_CON} and during IEC 61000-4-5 surge events of up to 100 V.

8.3.6 Powering the System When Battery is Discharged

There are two methods for powering the system under a dead battery condition. Case 1: The \overline{EN} pin can be tied to ground so that the nFET is always ON (when $V_{UVLO} < V_{BUS_CON} < V_{OVP}$) and an external charger can power V_{BUS} . Case 2: If \overline{EN} is controlled by a Power Management Unit (PMIC) or other logic, V_{BUS_POWER} can be used to power the PMIC. In Case 2, once the device is enabled, $t_{DELAY} + t_{SS}$, work together to meet the USB Inrush Current compliance.

8.3.7 ±15 kV IEC 61000-4-2 Level 4 ESD Protection

The V_{BUS_CON} pin can withstand ESD events up to ±15 kV Contact and Air-Gap. An ESD clamp diverts the current to ground.

8.3.8 100 V IEC 61000-4-5 μ s Surge Protection

The V_{BUS_CON} pin can withstand surge events up to 100 V open circuit voltage (V_{PP}), or 900 W. A Precision Clamp diverts the current to ground and active circuitry switches OFF the nFET earlier than 100 ns before an over voltage can get through to V_{BVS_SYS} . The ultra-fast response time of the TPD1S514 Family holds the voltage on V_{BUS_SYS} to less than V_{OVP} during surge events of up to 100 V_{PP} .

8.3.9 Startup and OVP Recovery Delay

Upon startup or recovering from an over voltage, the TPD1S514 Family of devices have a built in startup delay. An internal oscillator controls a charge pump to control the delay. Once a manufactured pre-programmed time, t_{DELAY} , has elapsed, the charge pump is enabled which turns ON the nFET. A manufactured pre-programmed soft start, t_{SS} , is used when turning ON the nFET. Once the device is enabled, these start delays, $t_{DELAY} + t_{SS}$, work together to meet the USB Inrush Current compliance.

8.3.10 Thermal Shutdown

The TPD1S514 Family has an over-temperature protection circuit to protect against system faults or improper use. The basic function of the thermal shutdown (TSD) circuit is to sense when the junction temperature has exceeded the absolute maximum rating and shuts down the device until the junction temperature has cooled to a safe level.

8.4 Device Functional Modes

8.4.1 Operation With $V_{BUS_CON} < 3.5\text{ V}$ (Minimum V_{BUS_CON})

The TPD1S514 Family operates normally (nFET ON) with input voltages above 3.5 V. The maximum UVLO voltage is 3.5 V and the device will operate at input voltages above 3.5 V. The typical UVLO voltage is 3.1 V and the device may operate at input voltages above that point. The device may also operate at input voltages as low as 2.7 V, the minimum UVLO. At input voltages between 0.6 V and 1.2 V, the state of output pins may not be controlled internally.

8.4.2 Operation With $V_{BUS_CON} > V_{OVP}$

The TPD1S514 Family operates normally (nFET ON) with input voltages below V_{OVP_min} . The typical OVP voltage is V_{OVP_TYP} and the device may operate at input voltages below that point. The device may also operate at input voltages as high as V_{OVP_MAX} .

Device Name	V_{OVP}		
	MIN	TYP	MAX
TPD1S514-1	5.9	5.95	5.99
TPD1S514-2	9.9	9.98	10.05
TPD1S514-3	13.5	13.75	14
TPD1S514	5.9	5.95	5.99

8.4.3 OTG Mode

The TPD1S514 Family of devices UVLO and OVP voltages are referenced to V_{BUS_CON} voltage. In OTG mode, V_{BUS_SYS} is driving the V_{BUS_CON} . Under this situation, initially V_{BUS_CON} is powered through the body diode of the nFET by V_{BUS_SYS} . Once the UVLO threshold on V_{BUS_CON} is met, the nFET turns ON. If there is a short to ground on V_{BUS_CON} the OTG supply is expected to limit the current.

9 Application and Implementation

NOTE

Information in the following applications sections is not part of the TI component specification, and TI does not warrant its accuracy or completeness. TI's customers are responsible for determining suitability of components for their purposes. Customers should validate and test their design implementation to confirm system functionality.

9.1 Application Information

The TPD1S514 Family of devices offer V_{BUS} port protection implementing UVLO and OVP, with an LDO supplied V_{BUS_POWER} pin to regulate an output supply pin of 3 mA at 5 V (except for TPD1S514, which follows V_{BUS_CON} up to 6.48 V, after which it is regulated to that voltage). The V_{BUS_POWER} pin can be used to power the system from an external source on V_{BUS_CON} in case the system's battery state cannot power the system.

9.2 Typical Application

9.2.1 TPD1S514-1 USB 2.0/3.0 Case 1: Always Enabled

The \overline{EN} pin can be tied to ground so that the nFET is ON when $V_{UVLO} < V_{BUS_CON} < V_{OVP}$ and an external charger can power V_{BUS} . V_{BUS_POWER} should be tied to ground with a 1- μ F capacitor for LDO stability. USB Inrush Current compliance tests will need to be handled by the rest of the system since the start delays t_{DELAY} and t_{SS} implement only after the device changes from disabled to enabled, or after any UVLO or OVP event.

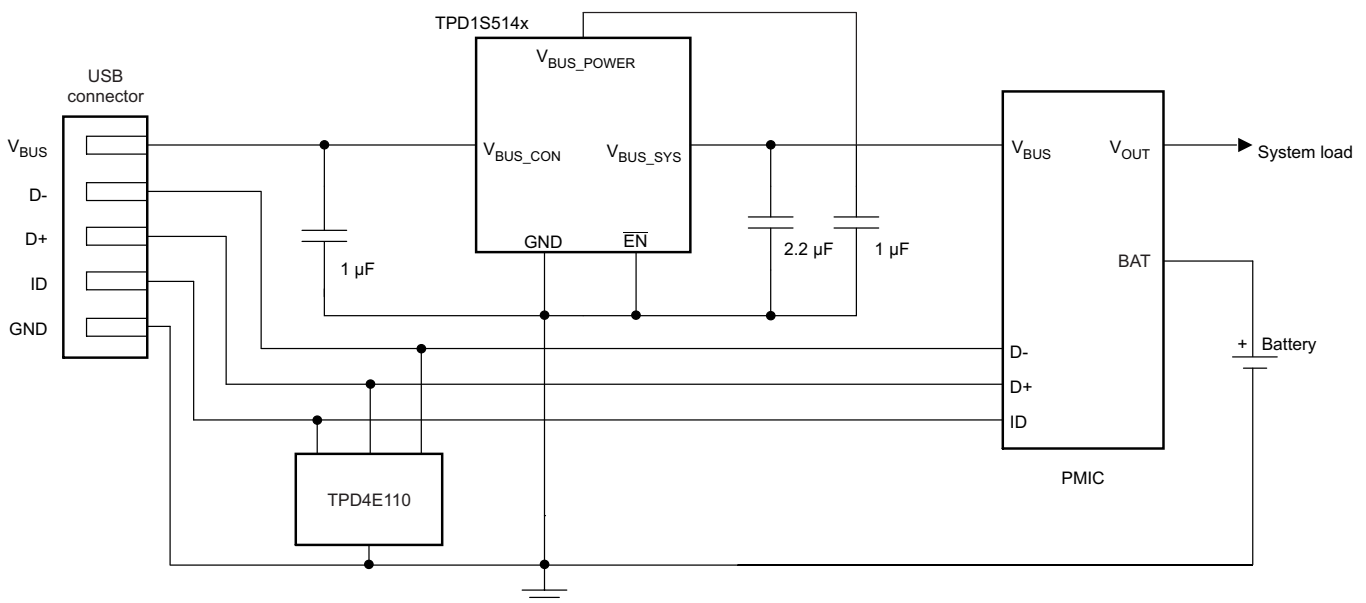

Figure 10. Always on, TPD1S514-1

9.2.1.1 Design Requirements

For this example, use the following table as input parameters:

Design Parameters	Example Value
Signal range on V_{BUS_CON}	3.5 V – 5.9 V
Signal range on V_{BUS_SYS}	3.9 V – 5.9 V
Signal on \overline{EN}	Tie to system ground plane

9.2.1.2 Detailed Design Procedure

To begin the design process the designer needs to know the V_{BUS} voltage range.

9.2.1.2.1 V_{BUS} Voltage Range

The UVLO trip-point is a maximum 3.5 V and the OVP trip-point is a minimum 5.9 V. This provides some headroom for the USB 2.0 specified minimum 4.4 V (Low-power) or 4.75 V (Full-power) and 5.25 V maximum; or the USB 3.0 specified minimum 4.45 V and 5.25 V maximum.

9.2.1.2.2 Discharged Battery

Connecting \overline{EN} to ground sets the part active at all times. OVP and UVLO are always active, even when the system battery is fully discharged. In the case of a discharged system battery, V_{BUS_SYS} can be used to power the system when a source with voltage between V_{UVLO} and V_{OVP} is attached to V_{BUS_CON} .

9.2.1.3 Application Curves

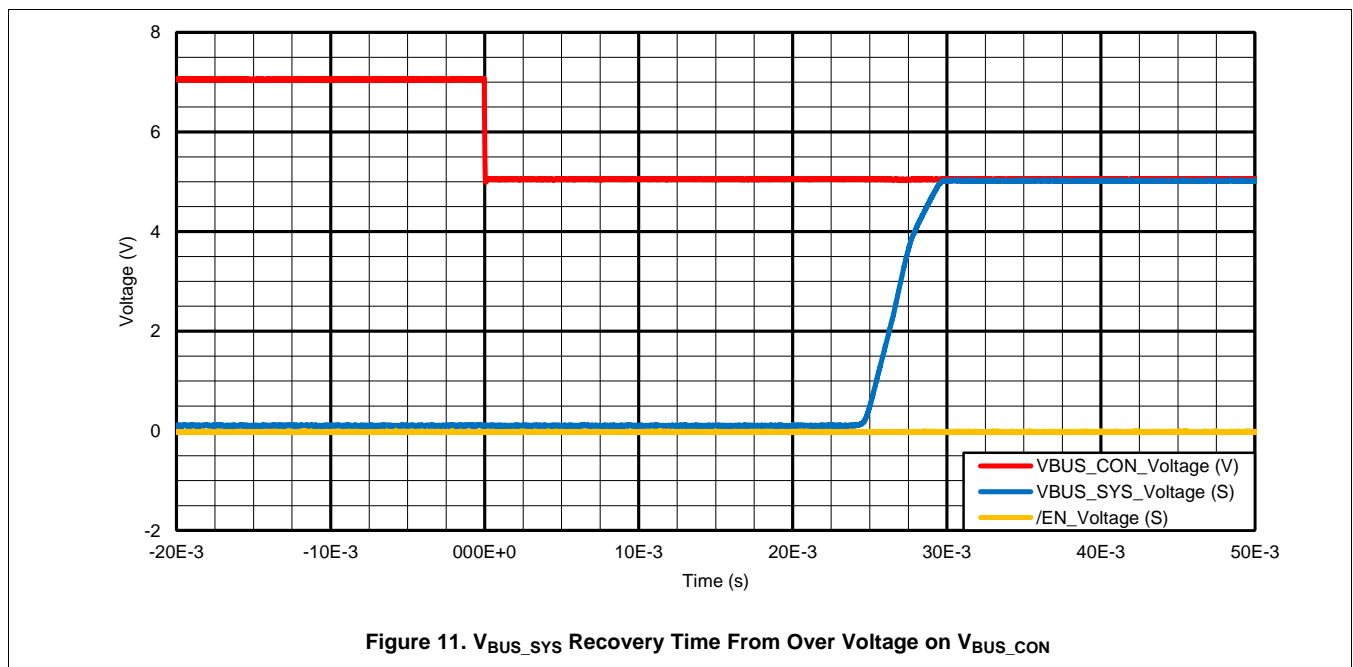

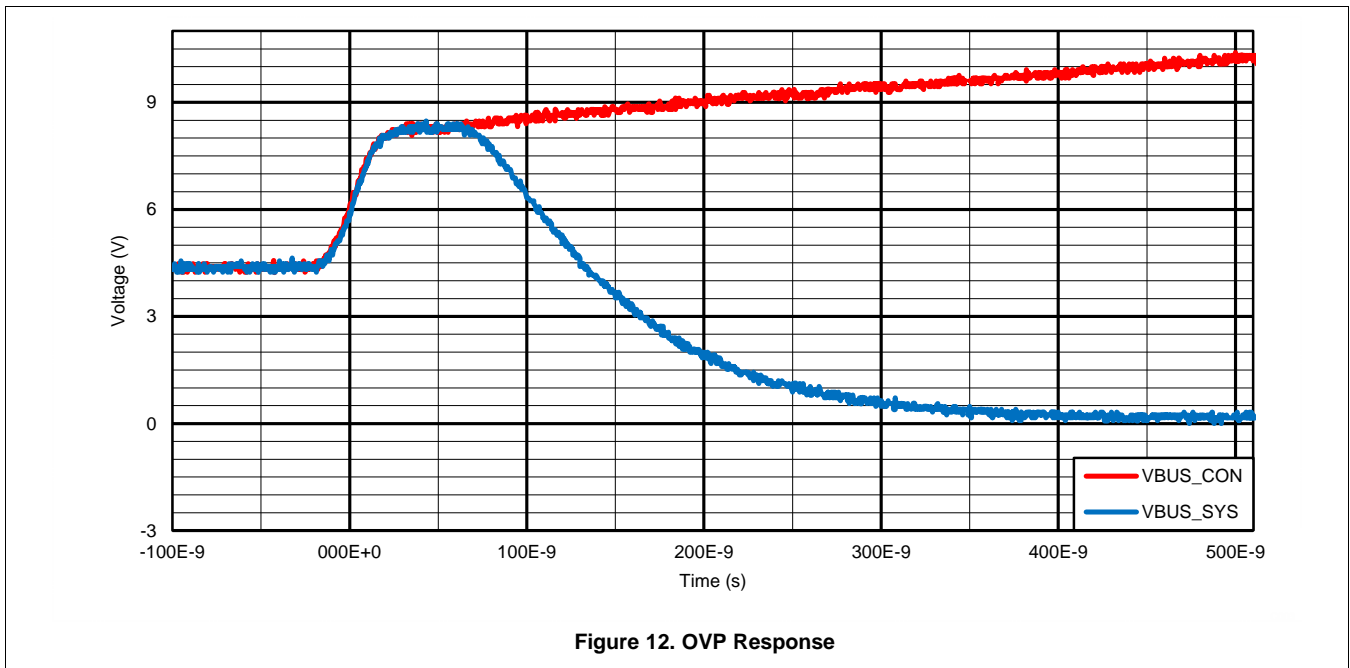

9.2.2 TPD1S514-1 USB 2.0/3.0 Case 2: PMIC Controlled \overline{EN}

The TPD1S514 Family offers more flexibility to system designers to power up the system during a dead battery condition. Refer to [Figure 13](#), the V_{BUS_POWER} pin supplies 4.95 V and 3 mA to power the PMIC in a dead battery condition. Regardless of \overline{EN} state, V_{BUS_POWER} is available to the PMIC. Utilizing this power, the PMIC can enable the TPD1S514 Family of devices when a valid V_{BUS_CON} voltage is present.

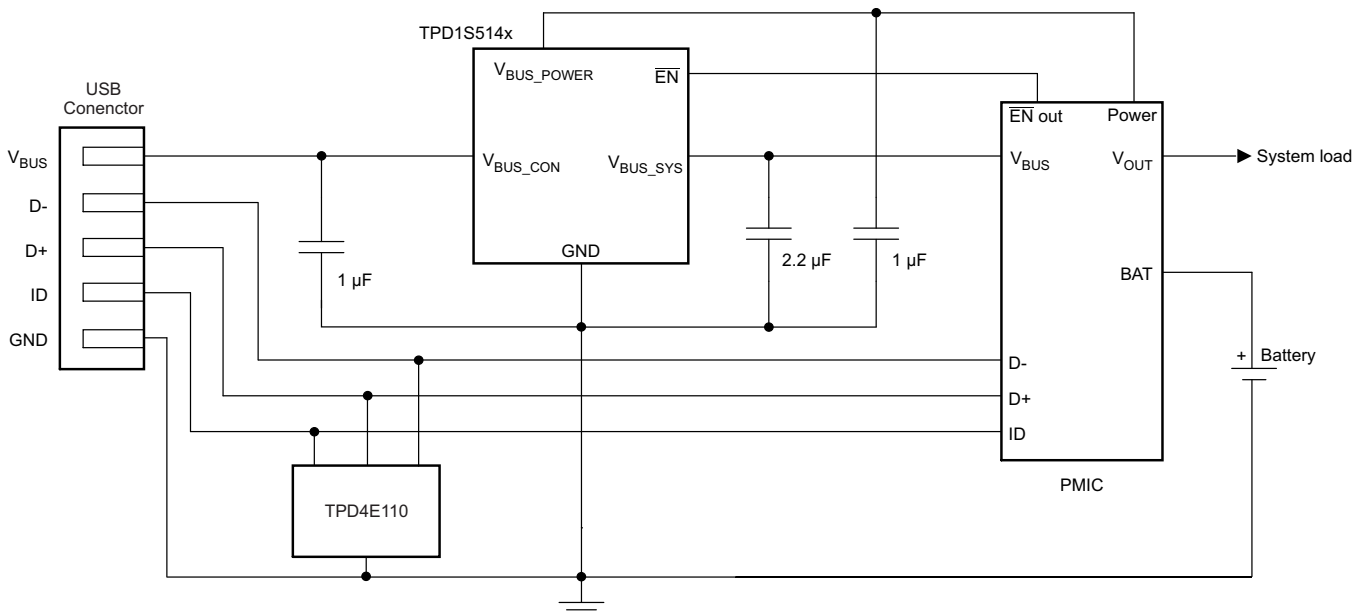

Figure 13. PMIC Controlled \overline{EN} , TPD1S514-1

9.2.2.1 Design Requirements

For this example, use the following table as input parameters:

Design Parameters	Example Value
Signal range on V_{BUS_CON}	3.5 V – 5.9 V
Signal range on V_{BUS_SYS}	3.9 V – 5.9 V
Drive \overline{EN} low (enabled)	0 V – 0.8 V
Drive \overline{EN} high (disabled)	1.2 V – 6.0 V

9.2.2.2 Detailed Design Procedure

To begin the design process, some parameters must be decided upon. The designer needs to know the following:

- V_{BUS} voltage range
- PMIC power requirement

9.2.2.2.1 V_{BUS} Voltage Range

The UVLO trip-point is a maximum 3.5 V and the OVP trip-point is a minimum 5.9 V. This provides some headroom for the USB 2.0 specified minimum 4.4 V (Low-power) or 4.75 V (Full-power) and 5.25 V maximum; or the USB 3.0 specified minimum 4.45 V and 5.25 V maximum.

9.2.2.2.2 PMIC Power Requirement

The V_{BUS_POWER} pin can source up to 3 mA of current and maintain a minimum 4.8 V, 4.95 V typical. TPD1S514-1 design provides an LDO regulator supplied voltage source which can be used to provide power to a PMIC when its internal battery supplied power is unavailable. When selecting a matching PMIC, ensure its power requirement can be met by the V_{BUS_POWER} pin if designing for this scenario.

9.2.2.2.3 Discharged Battery

Powering the PMIC from V_{BUS_POWER} allows logic control of the \overline{EN} pin to set TPD1S514-1 active and begin charging the battery and powering up the rest of the system.

9.2.2.3 Application Curves

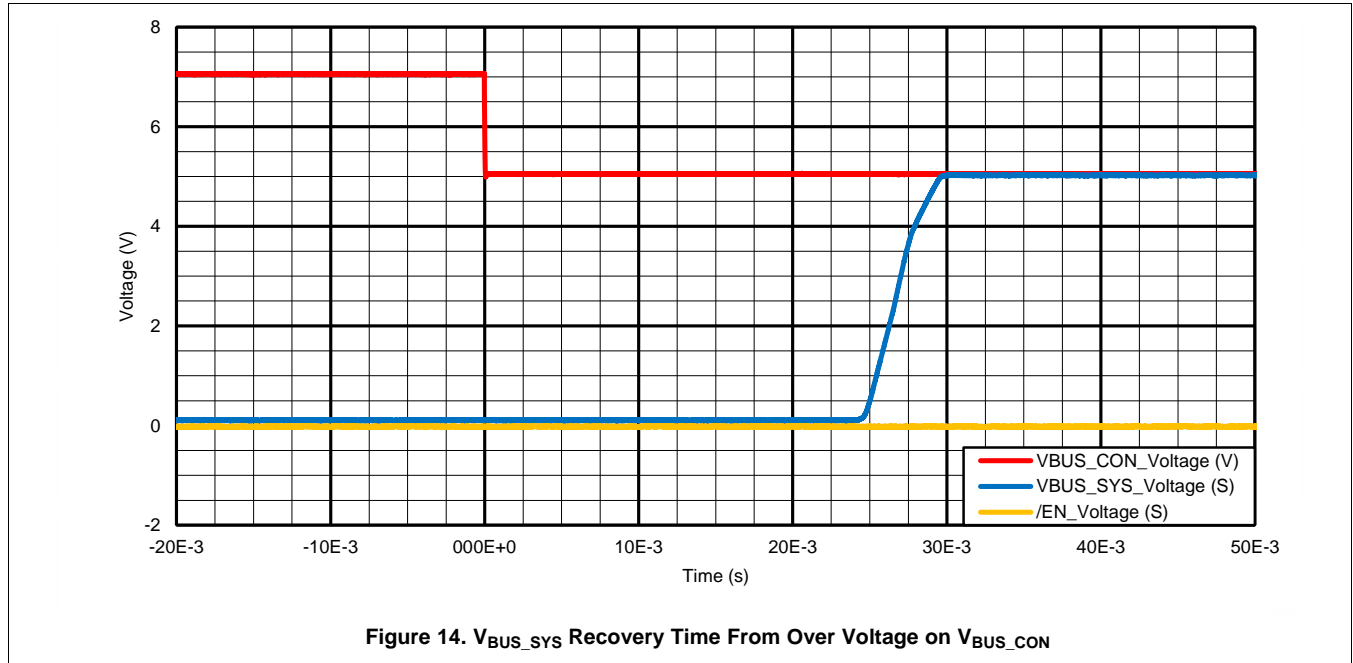

10 Power Supply Recommendations

The TPD1S514 Family is designed to receive power from a USB 3.0 (or lower) V_{BUS} source. It can operate normally (nFET ON) between a minimum 3.5 V and a maximum V_{OVP_MIN} V. Thus, the power supply (with a ripple of V_{RIPPLE}) requirement for the TPD1S514 Family of devices to be able to switch the nFET ON is between $3.5\text{ V} + V_{RIPPLE}$ and $V_{OVP_MIN} - V_{RIPPLE}$, where V_{OVP_MIN} is:

Device Name	V_{OVP_MIN}
TPD1S514-1	5.90 V
TPD1S514-2	9.9 V
TPD1S514-3	13.5 V
TPD1S514	5.90 V

11 Layout

11.1 Layout Guidelines

- The optimum placement is as close to the connector as possible.
 - EMI during an ESD event can couple from the trace being struck to other nearby unprotected traces, resulting in early system failures.
 - The PCB designer needs to minimize the possibility of EMI coupling by keeping any unprotected traces away from the protected traces which are between the TVS and the connector.
- Route the protected traces as straight as possible.
- Eliminate any sharp corners on the protected traces between the TVS and the connector by using rounded corners with the largest radii possible.
 - Electric fields tend to build up on corners, increasing EMI coupling.

11.2 Layout Example

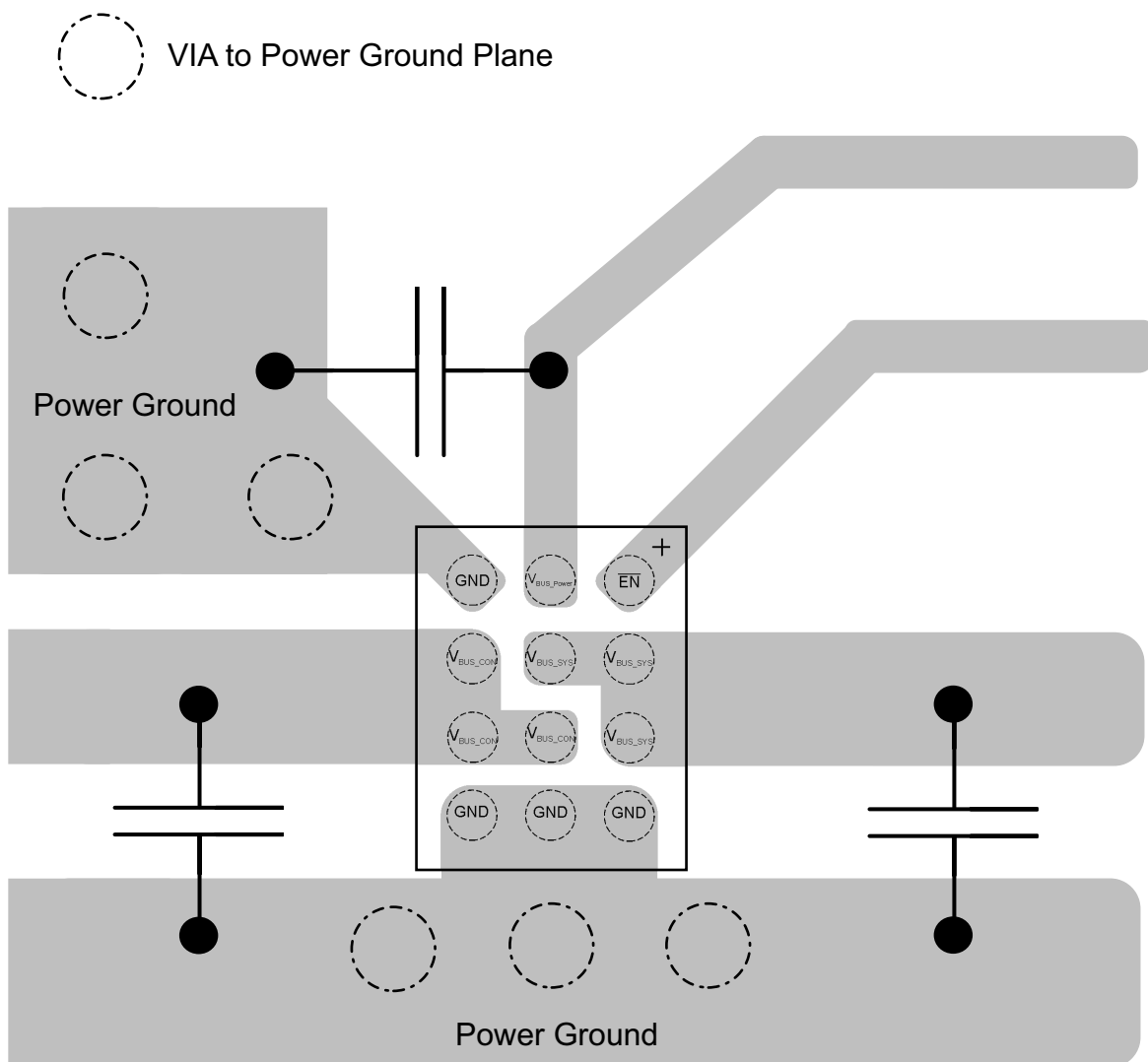

When designing layout for the TPD1S514 Family, note that V_{BUS_CON} and V_{BUS_SYS} pins allow extra wide traces for good power delivery. In the example shown, these pins are routed with 50 mil (1.27 mm) wide traces. Place the V_{BUS_CON} , V_{BUS_SYS} , and V_{BUS_POWER} capacitors as close to the pins as possible. Use external and internal ground planes and stitch them together with VIAs as close to the GND pins of TPD1S514 as possible. This allows for a low impedance path to ground so that the device can properly dissipate any surge or ESD events.

12 Device and Documentation Support

12.1 Community Resources

The following links connect to TI community resources. Linked contents are provided "AS IS" by the respective contributors. They do not constitute TI specifications and do not necessarily reflect TI's views; see TI's [Terms of Use](#).

TI E2E™ Online Community *TI's Engineer-to-Engineer (E2E) Community*. Created to foster collaboration among engineers. At e2e.ti.com, you can ask questions, share knowledge, explore ideas and help solve problems with fellow engineers.

Design Support *TI's Design Support* Quickly find helpful E2E forums along with design support tools and contact information for technical support.

12.2 Trademarks

E2E is a trademark of Texas Instruments.
All other trademarks are the property of their respective owners.

12.3 Electrostatic Discharge Caution



This integrated circuit can be damaged by ESD. Texas Instruments recommends that all integrated circuits be handled with appropriate precautions. Failure to observe proper handling and installation procedures can cause damage.

ESD damage can range from subtle performance degradation to complete device failure. Precision integrated circuits may be more susceptible to damage because very small parametric changes could cause the device not to meet its published specifications.

12.4 Glossary

[SLYZ022](#) — *TI Glossary*.

This glossary lists and explains terms, acronyms, and definitions.

13 Mechanical, Packaging, and Orderable Information

The following pages include mechanical packaging and orderable information. This information is the most current data available for the designated devices. This data is subject to change without notice and revision of this document. For browser-based versions of this data sheet, refer to the left-hand navigation.

TPD1S514-xYZ

YZ0012-C01

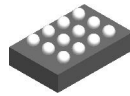

PACKAGE OUTLINE

DSBGA - 0.625 mm max height

DIE SIZE BALL GRID ARRAY

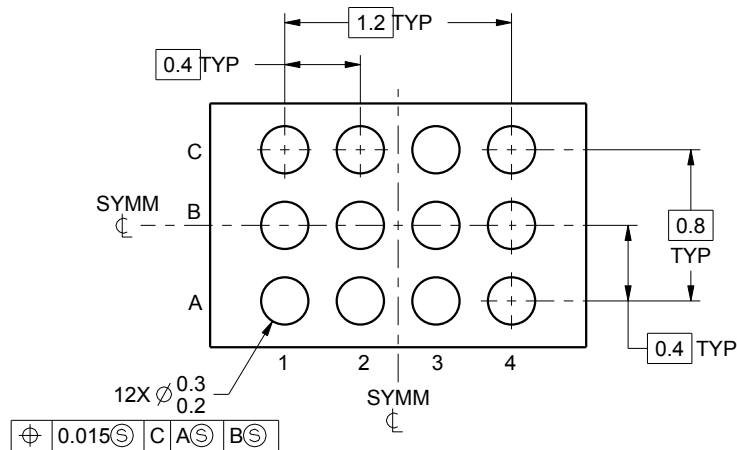
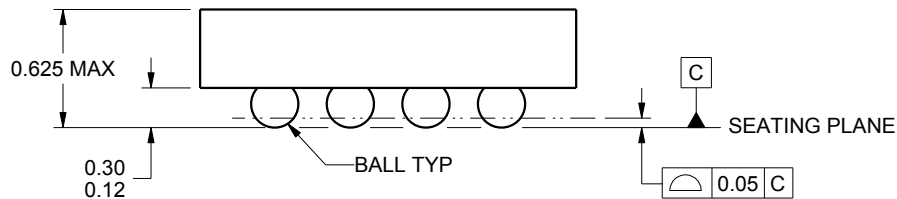
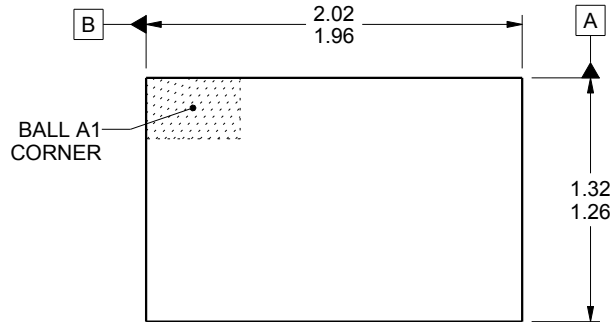

4221703/A 11/2014

NOTES:

1. All linear dimensions are in millimeters. Any dimensions in parenthesis are for reference only. Dimensioning and tolerancing per ASME Y14.5M.
2. This drawing is subject to change without notice.

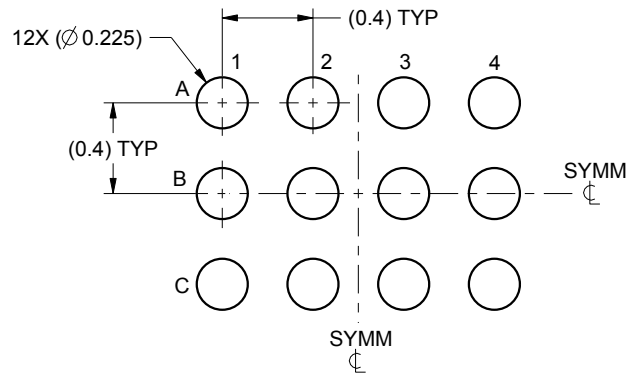

LAND PATTERN EXAMPLE
SCALE:30X

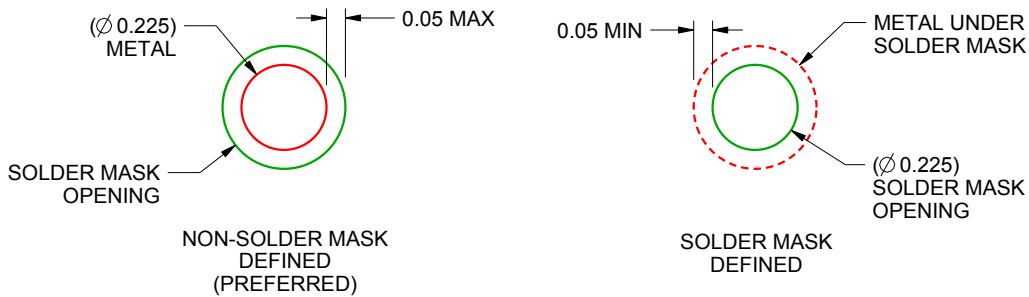

SOLDER MASK DETAILS
NOT TO SCALE

4221703/A 11/2014

NOTES: (continued)

3. Final dimensions may vary due to manufacturing tolerance considerations and also routing constraints. For more information, see Texas Instruments literature number SBVA017 (www.ti.com/lit/sbva017).

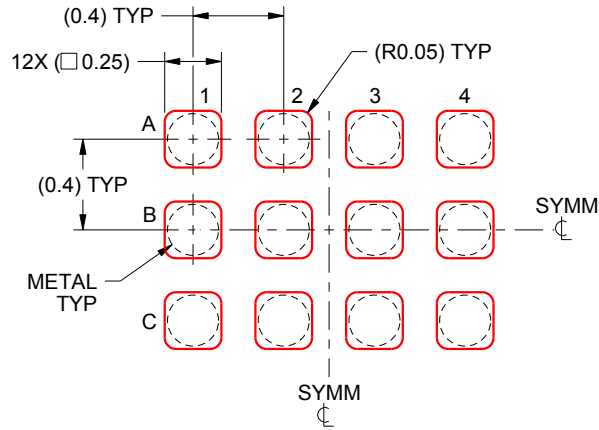

SOLDER PASTE EXAMPLE
BASED ON 0.1 mm THICK STENCIL
SCALE:30X

4221703/A 11/2014

NOTES: (continued)

4. Laser cutting apertures with trapezoidal walls and rounded corners may offer better paste release.

PACKAGING INFORMATION

Orderable Device	Status (1)	Package Type	Package Drawing	Pins	Package Qty	Eco Plan (2)	Lead/Ball Finish (6)	MSL Peak Temp (3)	Op Temp (°C)	Device Marking (4/5)	Samples
TPD1S514-1YZR	ACTIVE	DSBGA	YZ	12	3000	Green (RoHS & no Sb/Br)	SNAGCU	Level-1-260C-UNLIM	-40 to 85	RH5141	Samples
TPD1S514-2YZR	ACTIVE	DSBGA	YZ	12	3000	Green (RoHS & no Sb/Br)	SNAGCU	Level-1-260C-UNLIM	-40 to 85	RH5142	Samples
TPD1S514-3YZR	ACTIVE	DSBGA	YZ	12	3000	Green (RoHS & no Sb/Br)	SNAGCU	Level-1-260C-UNLIM	-40 to 85	RH5143	Samples

(1) The marketing status values are defined as follows:

ACTIVE: Product device recommended for new designs.

LIFEBUY: TI has announced that the device will be discontinued, and a lifetime-buy period is in effect.

NRND: Not recommended for new designs. Device is in production to support existing customers, but TI does not recommend using this part in a new design.

PREVIEW: Device has been announced but is not in production. Samples may or may not be available.

OBSOLETE: TI has discontinued the production of the device.

(2) Eco Plan - The planned eco-friendly classification: Pb-Free (RoHS), Pb-Free (RoHS Exempt), or Green (RoHS & no Sb/Br) - please check <http://www.ti.com/productcontent> for the latest availability information and additional product content details.

TBD: The Pb-Free/Green conversion plan has not been defined.

Pb-Free (RoHS): TI's terms "Lead-Free" or "Pb-Free" mean semiconductor products that are compatible with the current RoHS requirements for all 6 substances, including the requirement that lead not exceed 0.1% by weight in homogeneous materials. Where designed to be soldered at high temperatures, TI Pb-Free products are suitable for use in specified lead-free processes.

Pb-Free (RoHS Exempt): This component has a RoHS exemption for either 1) lead-based flip-chip solder bumps used between the die and package, or 2) lead-based die adhesive used between the die and leadframe. The component is otherwise considered Pb-Free (RoHS compatible) as defined above.

Green (RoHS & no Sb/Br): TI defines "Green" to mean Pb-Free (RoHS compatible), and free of Bromine (Br) and Antimony (Sb) based flame retardants (Br or Sb do not exceed 0.1% by weight in homogeneous material)

(3) MSL, Peak Temp. - The Moisture Sensitivity Level rating according to the JEDEC industry standard classifications, and peak solder temperature.

(4) There may be additional marking, which relates to the logo, the lot trace code information, or the environmental category on the device.

(5) Multiple Device Markings will be inside parentheses. Only one Device Marking contained in parentheses and separated by a "~" will appear on a device. If a line is indented then it is a continuation of the previous line and the two combined represent the entire Device Marking for that device.

(6) Lead/Ball Finish - Orderable Devices may have multiple material finish options. Finish options are separated by a vertical ruled line. Lead/Ball Finish values may wrap to two lines if the finish value exceeds the maximum column width.

Important Information and Disclaimer: The information provided on this page represents TI's knowledge and belief as of the date that it is provided. TI bases its knowledge and belief on information provided by third parties, and makes no representation or warranty as to the accuracy of such information. Efforts are underway to better integrate information from third parties. TI has taken and

continues to take reasonable steps to provide representative and accurate information but may not have conducted destructive testing or chemical analysis on incoming materials and chemicals. TI and TI suppliers consider certain information to be proprietary, and thus CAS numbers and other limited information may not be available for release.

In no event shall TI's liability arising out of such information exceed the total purchase price of the TI part(s) at issue in this document sold by TI to Customer on an annual basis.

TAPE AND REEL INFORMATION



QUADRANT ASSIGNMENTS FOR PIN 1 ORIENTATION IN TAPE



*All dimensions are nominal

Device	Package Type	Package Drawing	Pins	SPQ	Reel Diameter (mm)	Reel Width W1 (mm)	A0 (mm)	B0 (mm)	K0 (mm)	P1 (mm)	W (mm)	Pin1 Quadrant
TPD1S514-1YZR	DSBGA	YZ	12	3000	180.0	8.4	1.39	2.09	0.75	4.0	8.0	Q2

TAPE AND REEL BOX DIMENSIONS

*All dimensions are nominal

Device	Package Type	Package Drawing	Pins	SPQ	Length (mm)	Width (mm)	Height (mm)
TPD1S514-1YZR	DSBGA	YZ	12	3000	182.0	182.0	20.0

IMPORTANT NOTICE

Texas Instruments Incorporated and its subsidiaries (TI) reserve the right to make corrections, enhancements, improvements and other changes to its semiconductor products and services per JESD46, latest issue, and to discontinue any product or service per JESD48, latest issue. Buyers should obtain the latest relevant information before placing orders and should verify that such information is current and complete. All semiconductor products (also referred to herein as "components") are sold subject to TI's terms and conditions of sale supplied at the time of order acknowledgment.

TI warrants performance of its components to the specifications applicable at the time of sale, in accordance with the warranty in TI's terms and conditions of sale of semiconductor products. Testing and other quality control techniques are used to the extent TI deems necessary to support this warranty. Except where mandated by applicable law, testing of all parameters of each component is not necessarily performed.

TI assumes no liability for applications assistance or the design of Buyers' products. Buyers are responsible for their products and applications using TI components. To minimize the risks associated with Buyers' products and applications, Buyers should provide adequate design and operating safeguards.

TI does not warrant or represent that any license, either express or implied, is granted under any patent right, copyright, mask work right, or other intellectual property right relating to any combination, machine, or process in which TI components or services are used. Information published by TI regarding third-party products or services does not constitute a license to use such products or services or a warranty or endorsement thereof. Use of such information may require a license from a third party under the patents or other intellectual property of the third party, or a license from TI under the patents or other intellectual property of TI.

Reproduction of significant portions of TI information in TI data books or data sheets is permissible only if reproduction is without alteration and is accompanied by all associated warranties, conditions, limitations, and notices. TI is not responsible or liable for such altered documentation. Information of third parties may be subject to additional restrictions.

Resale of TI components or services with statements different from or beyond the parameters stated by TI for that component or service voids all express and any implied warranties for the associated TI component or service and is an unfair and deceptive business practice. TI is not responsible or liable for any such statements.

Buyer acknowledges and agrees that it is solely responsible for compliance with all legal, regulatory and safety-related requirements concerning its products, and any use of TI components in its applications, notwithstanding any applications-related information or support that may be provided by TI. Buyer represents and agrees that it has all the necessary expertise to create and implement safeguards which anticipate dangerous consequences of failures, monitor failures and their consequences, lessen the likelihood of failures that might cause harm and take appropriate remedial actions. Buyer will fully indemnify TI and its representatives against any damages arising out of the use of any TI components in safety-critical applications.

In some cases, TI components may be promoted specifically to facilitate safety-related applications. With such components, TI's goal is to help enable customers to design and create their own end-product solutions that meet applicable functional safety standards and requirements. Nonetheless, such components are subject to these terms.

No TI components are authorized for use in FDA Class III (or similar life-critical medical equipment) unless authorized officers of the parties have executed a special agreement specifically governing such use.

Only those TI components which TI has specifically designated as military grade or "enhanced plastic" are designed and intended for use in military/aerospace applications or environments. Buyer acknowledges and agrees that any military or aerospace use of TI components which have **not** been so designated is solely at the Buyer's risk, and that Buyer is solely responsible for compliance with all legal and regulatory requirements in connection with such use.

TI has specifically designated certain components as meeting ISO/TS16949 requirements, mainly for automotive use. In any case of use of non-designated products, TI will not be responsible for any failure to meet ISO/TS16949.

Products

Audio	www.ti.com/audio
Amplifiers	amplifier.ti.com
Data Converters	dataconverter.ti.com
DLP® Products	www.dlp.com
DSP	dsp.ti.com
Clocks and Timers	www.ti.com/clocks
Interface	interface.ti.com
Logic	logic.ti.com
Power Mgmt	power.ti.com
Microcontrollers	microcontroller.ti.com
RFID	www.ti-rfid.com
OMAP Applications Processors	www.ti.com/omap
Wireless Connectivity	www.ti.com/wirelessconnectivity

Applications

Automotive and Transportation	www.ti.com/automotive
Communications and Telecom	www.ti.com/communications
Computers and Peripherals	www.ti.com/computers
Consumer Electronics	www.ti.com/consumer-apps
Energy and Lighting	www.ti.com/energy
Industrial	www.ti.com/industrial
Medical	www.ti.com/medical
Security	www.ti.com/security
Space, Avionics and Defense	www.ti.com/space-avionics-defense
Video and Imaging	www.ti.com/video

TI E2E Community

e2e.ti.com