

MBR10200CT/FCT/CS

10 AMPERES SCHOTTKY BARRIER RECTIFIERS

VOLTAGE 200 Volt **CURRENT** 10 Ampere

FEATURES

- Plastic package has Underwriters Laboratory Flammability Classification 94V-O. Flame Retardant Epoxy Molding Compound.
- Low power loss, high efficiency.
- High current capability
- For use in low voltage, high frequency inverters free wheeling, and polarity protection applications.
- Lead free in compliance with EU RoHS 2011/65/EU directive

MECHANICAL DATA

Device Weight : 0.07 ounces (1.96grams) - TO -220AB
 0.06 ounces (1.74grams) - ITO -220AB
 0.01 ounces (0.3grams) - TO -252

- Terminals: solder plated, solderable per MIL-STD-750, Method 2026
- Polarity: As marked.

Mounting Torque : Recommended 4~5 kg-cm.

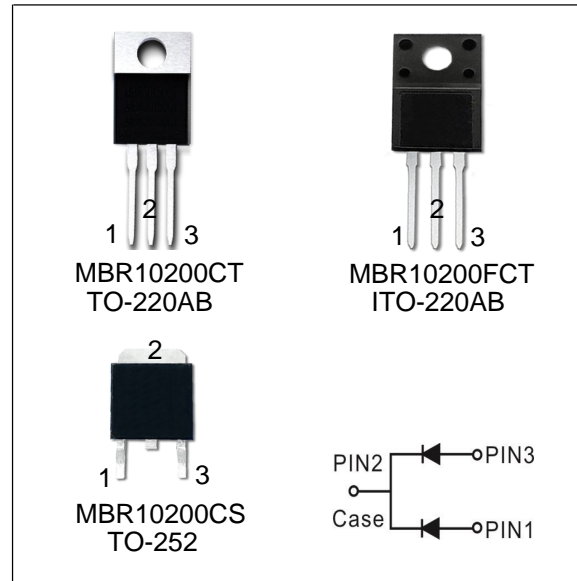

MARK: AEXXX

MAXIMUM RATINGS($T_A=25^{\circ}\text{C}$ unless otherwise noted)

PARAMETER	SYMBOL	VALUE	UNIT
Maximum repetitive peak reverse voltage	V_{RRM}	200	V
Maximum average forward rectified current	$I_{F(AV)}$	5 10	A
Peak forward surge current 8.3ms single half sine-wave superimposed on rated load	I_{FSM}	130	A
Typical junction capacitance ($V_R=4V$, $f=1\text{MHz}$)	C_J	50	pF
Typical thermal resistance per diode (Note 1)	$R_{\theta JC}$	2.0	$^{\circ}\text{C/W}$
Operating junction temperature range	T_J	-40 to + 150	$^{\circ}\text{C}$
Storage temperature range	T_{STG}	-40 to + 150	$^{\circ}\text{C}$

Note : 1. Mounted on infinite heatsink.

ELECTRICAL CHARACTERISTICS($T_A=25^{\circ}\text{C}$ unless otherwise noted)

PARAMETER	SYMBOL	TEST CONDITIONS	MIN.	TYP.	MAX.	UNIT
Breakdown voltage per diode	V_{BR}	$I_R=0.1\text{mA}$	200	-	-	V
Instantaneous forward voltage per diode	V_F	$I_F=5\text{A}$ $T_J=25^{\circ}\text{C}$	-	0.85	0.90	V
Reverse current per diode	I_R	$V_R=200\text{V}$ $T_J=25^{\circ}\text{C}$	-	0.5	5	μA

MBR10200CT/FCT/CS

RATING AND CHARACTERISTIC CURVES

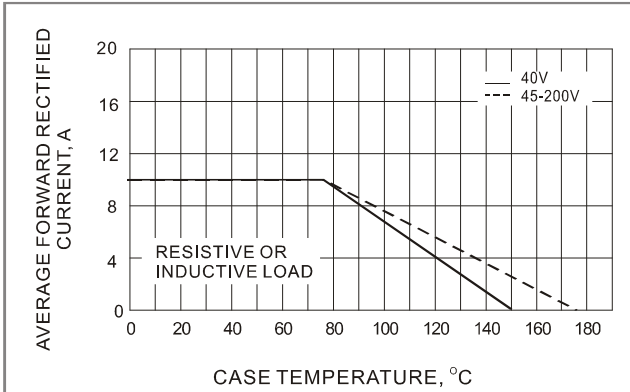

Fig.1- FORWARD CURRENT DERATING CURVE

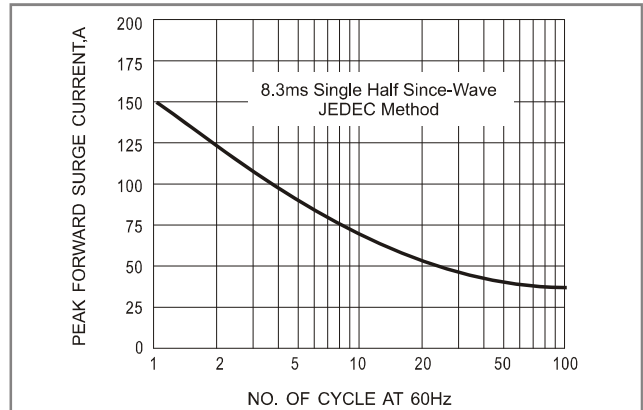

Fig.2- TYPICAL INSTANTANEOUS FORWARD CHARACTERISTICS

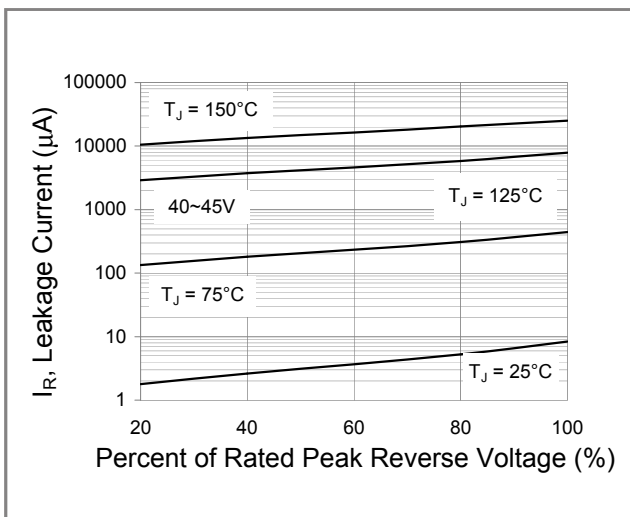

Fig.3- TYPICAL REVERSE CHARACTERISTICS

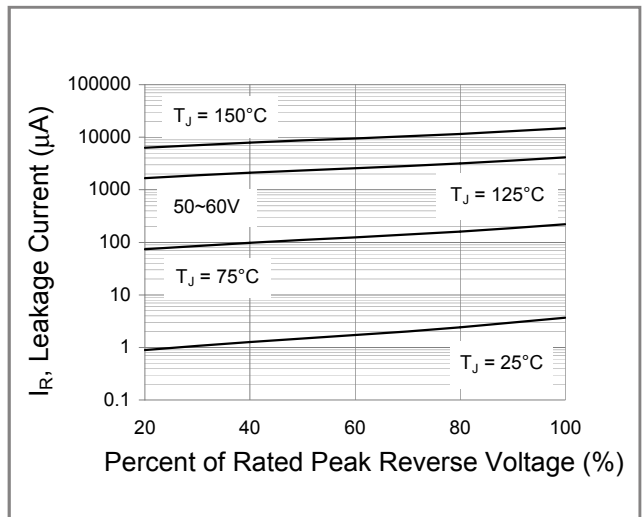

Fig.4- TYPICAL REVERSE CHARACTERISTICS

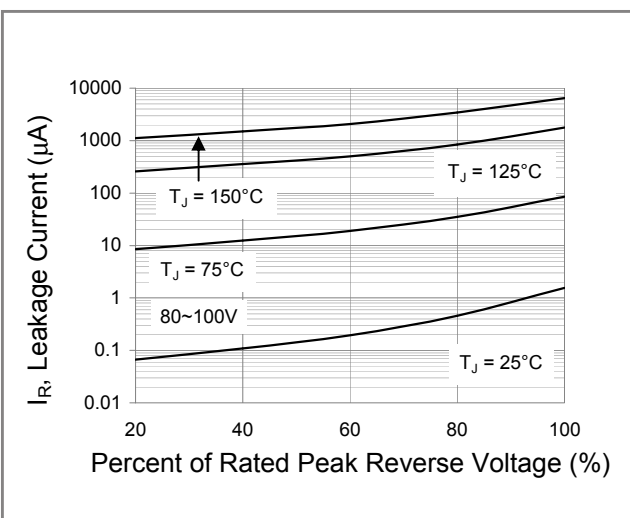

Fig.5- TYPICAL REVERSE CHARACTERISTICS

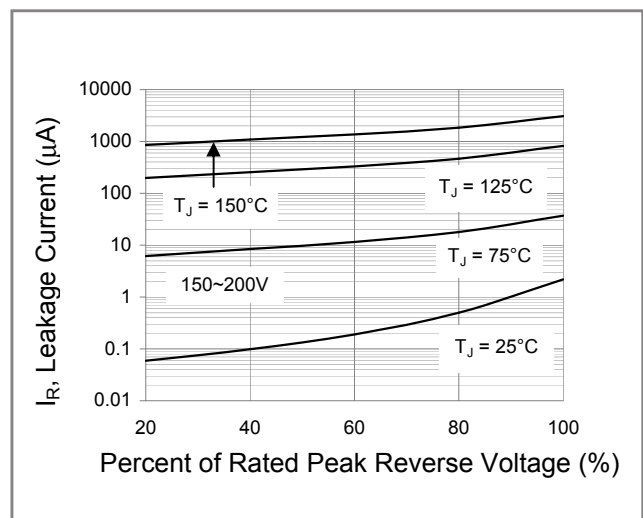
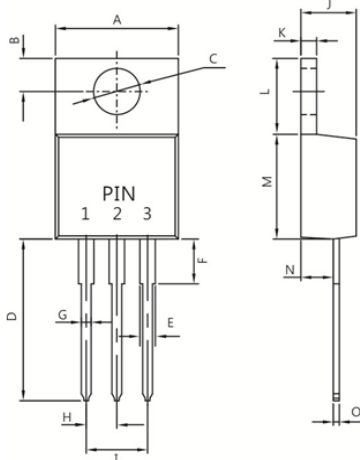

Fig.6- TYPICAL REVERSE CHARACTERISTICS

MBR10200CT/FCT/CS

TO-220AB

Dim.	Min.	Max.
A	----	10.50
B	2.50	3.50
C	3.50	4.10
D	13.10	13.90
E	1.15	1.49
F	----	6.35
G	0.65	0.95
H	2.29	2.79
I	4.80	5.30
J	4.40	4.80
K	1.14	1.40
L	5.84	6.86
M	8.50	9.60
N	2.03	2.92
O	0.30	0.64

All Dimensions in millimeter

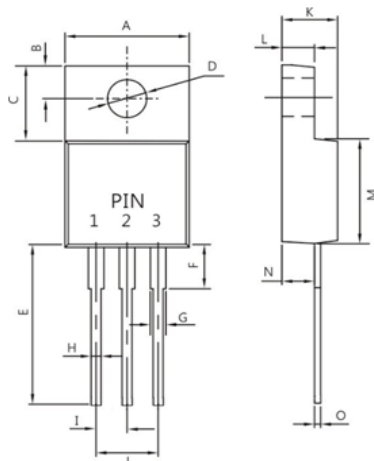
ITO-220AB

Dim.	Min.	Max.
A	----	10.50
B	2.60	3.00
C	6.70	7.10
D	2.90	3.50
E	13.10	13.90
F	----	4.00
G	1.11	1.45
H	0.40	0.80
I	2.40	2.80
J	5.00	5.40
K	4.30	4.70
L	2.90	3.30
M	8.20	9.00
N	2.50	2.90
O	0.40	0.80

All Dimensions in millimeter

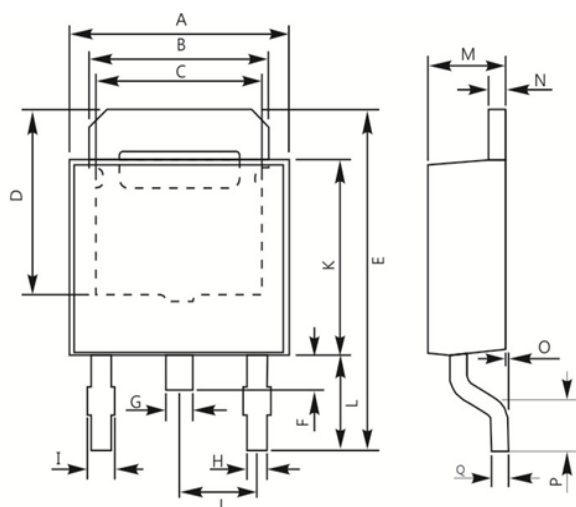
TO-252

Dim.	Min.	Max.
A	6.40	6.80
B	5.20	5.50
C	3.80	----
D	4.75	----
E	9.40	10.20
F	0.80	1.20
G	0.70	0.90
H	0.50	0.70
I	0.60	0.90
J	2.30	Ref.
K	5.40	5.80
L	2.40	3.00
M	2.20	2.40
N	0.45	0.55
O	----	0.15
P	1.40	1.77
Q	0.508	Typ.

All Dimensions in millimeter