

- STRUCTURE Silicon Monolithic Integrated Circuit
- PRODUCT SERIES Analog Output Ambient Light Sensor IC
- TYPE **BH1600FVC**
- FUNCTION 1. Compact surface mount package 3.0 × 1.6 mm
 2. Spectral responsibility is approximates human eyes response
 3. Output current which is proportionate to the light
 4. Supply voltage operates from 2.4V
 5. Built-in shutdown function
 6. Control output current gain in 2 steps is possible
 7. 1.8V logic input interface

● Absolute Maximum Ratings (Ta=25°C)

Parameter	Symbol	Limits	Units
Supply Voltage	Vmax	4.5	V
Operating Temperature	Topr	-30~85	°C
Storage Temperature	Tstg	-40~100	°C
Iout Current	Ioutmax	7.5	mA
Power Dissipation	Pd	260※	mW

※70mm × 70mm × 1.6mm glass epoxy board. Derating in done at 3.47mW/°C for operating above Ta=25°C.

● Operating Conditions

Parameter	Symbol	Min.	Typ.	Max.	Units
VCC Voltage	Vcc	2.4	3.0	3.6	V

NOTE: This product is not designed for protection against radioactive rays.

This product does not include laser transmitter. This product does not include optical load.

This product includes Photodetector, (Photo Diode) inside of it.

·Status of this document

The Japanese version of this document is the formal specification. A customer may use this translation version only for a reference to help reading the formal version. If there are any differences in translation version of this document, formal version takes priority.

●Electrical Characteristics (VCC=3.0V,Ta=25°C)

Parameter	Symbol	Min.	Typ.	Max.	Units	Conditions
Supply Current	I _{cc1}	39	64	90	uA	Ev=100 lx (H-Gain Mode) ※
Shutdown Current	I _{cc2sd}	-	0.01	0.2	uA	V _{GC1} =V _{GC2} =0 No Input Light
Dark Current	I _{dark}	-	-	0.1	uA	Ev=0 lx
Light Current	I _{out}	39	60	81	uA	Ev=100 lx (H-Gain Mode) ※
Saturated Output Voltage	V _{OMAX}	2.6	2.9	3.0	V	Ev=100 lx, RL=220kΩ (H-Gain Mode) ※
GC1, GC2 Input 'L' Voltage	V _{IL}	0	-	0.4	V	
GC1,GC2 Input 'H' Voltage	V _{IH}	1.4	-	V _{CC}	V	
Wake-up Time	twu	-	64	128	us	Shutdown → H-Gain Mode Ev=100lx ※
Gain Ratio H-Gain Mode/L-Gain Mode		-	9.5	10	times	Ev=100lx ※

※ White LED is used as optical source

●Package Outlines

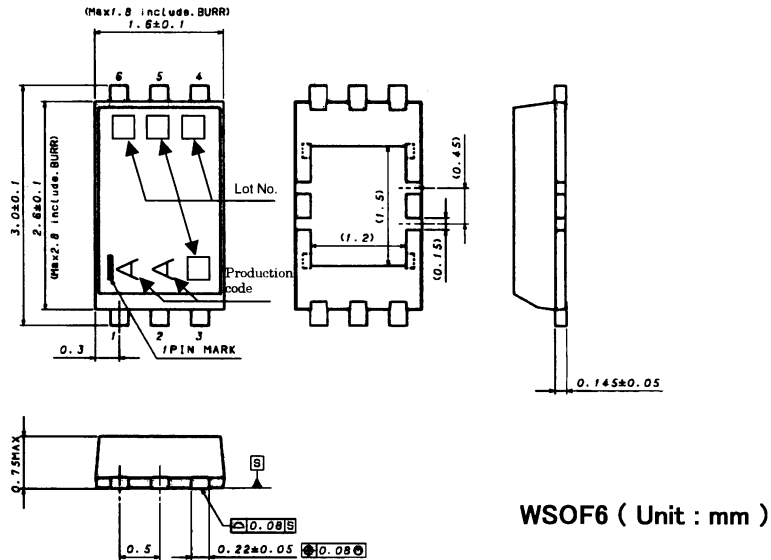

● Pin Description

Pin No.	Pin Name	Function
1	IOUT	Output current which is proportionate to the light. Use this pin putting resistor between GND.
2	GND	
3	VCC	
4	NC	OPEN or short circuit to GND.
5	GC1	Mode Setting Pin 1
6	GC2	Mode Setting Pin 2

● Block Diagram

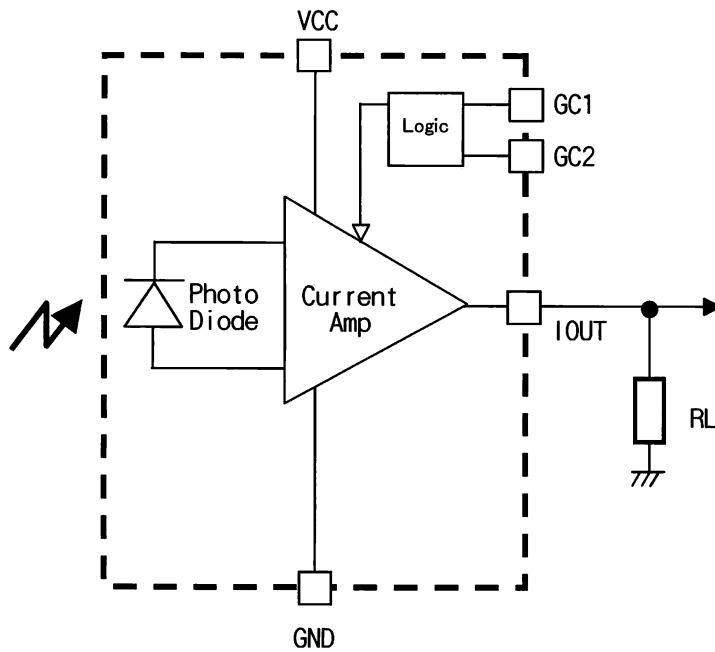

● Mode Setting

GC2	GC1	Mode
0	0	Shutdown
0	1	H-Gain Mode
1	0	L-Gain Mode
1	1	Test Mode(Input prohibition)

● Cautions on use

1) Absolute Maximum Ratings

An excess in the absolute maximum ratings, such as supply voltage (V_{max}), temperature range of operating conditions (T_{opr}), etc., can break down devices, thus making impossible to identify breaking mode such as a short circuit or an open circuit. If any special mode exceeding the absolute maximum ratings is assumed, consideration should be given to take physical safety measures including the use of fuses, etc.

2) GND voltage

Make setting of the potential of the GND terminal so that it will be maintained at the minimum in any operating state. Furthermore, check to be sure no terminals are at a potential lower than the GND voltage including an actual electric transient.

3) Short circuit between terminals and erroneous mounting

In order to mount ICs on a set PCB, pay thorough attention to the direction and offset of the ICs. Erroneous mounting can break down the ICs. Furthermore, if a short circuit occurs due to foreign matters entering between terminals or between the terminal and the power supply or the GND terminal, the ICs can break down.

4) Operation in strong electromagnetic field

Be noted that using ICs in the strong electromagnetic field can malfunction them.

5) Inspection with set PCB

On the inspection with the set PCB, if a capacitor is connected to a low-impedance IC terminal, the IC can suffer stress. Therefore, be sure to discharge from the set PCB by each process. Furthermore, in order to mount or dismount the set PCB to/from the jig for the inspection process, be sure to turn OFF the power supply and then mount the set PCB to the jig. After the completion of the inspection, be sure to turn OFF the power supply and then dismount it from the jig. In addition, for protection against static electricity, establish a ground for the assembly process and pay thorough attention to the transportation and the storage of the set PCB.

6) Input terminals

In terms of the construction of IC, parasitic elements are inevitably formed in relation to potential. The operation of the parasitic element can cause interference with circuit operation, thus resulting in a malfunction and then breakdown of the input terminal. Therefore, pay thorough attention not to handle the input terminals; such as to apply to the input terminals a voltage lower than the GND respectively, so that any parasitic element will operate. Furthermore, do not apply a voltage to the input terminals when no power supply voltage is applied to the IC. In addition, even if the power supply voltage is applied, apply to the input terminals a voltage lower than the power supply voltage or within the guaranteed value of electrical characteristics.

7) Thermal design

Perform thermal design in which there are adequate margins by taking into account the power dissipation (P_d) in actual states of use.

8) Treatment of package

Dusts or scratch on the photo detector may affect the optical characteristics. Please handle it with care.

9) When power is first supplied to this IC, rush current may flow instantaneously. Because it is possible that the charge current to the parastic capacitance of internal photo diode or the internal logic may be unstable.

Therefore, give special consideration to power coupling capacitance, power wiring, width of GND wiring, and routing of connections.

Notes

- No technical content pages of this document may be reproduced in any form or transmitted by any means without prior permission of ROHM CO.,LTD.
- The contents described herein are subject to change without notice. The specifications for the product described in this document are for reference only. Upon actual use, therefore, please request that specifications to be separately delivered.
- Application circuit diagrams and circuit constants contained herein are shown as examples of standard use and operation. Please pay careful attention to the peripheral conditions when designing circuits and deciding upon circuit constants in the set.
- Any data, including, but not limited to application circuit diagrams information, described herein are intended only as illustrations of such devices and not as the specifications for such devices. ROHM CO.,LTD. disclaims any warranty that any use of such devices shall be free from infringement of any third party's intellectual property rights or other proprietary rights, and further, assumes no liability of whatsoever nature in the event of any such infringement, or arising from or connected with or related to the use of such devices.
- Upon the sale of any such devices, other than for buyer's right to use such devices itself, resell or otherwise dispose of the same, no express or implied right or license to practice or commercially exploit any intellectual property rights or other proprietary rights owned or controlled by
- ROHM CO., LTD. is granted to any such buyer.
- Products listed in this document are no antiradiation design.

The products listed in this document are designed to be used with ordinary electronic equipment or devices (such as audio visual equipment, office-automation equipment, communications devices, electrical appliances and electronic toys).

Should you intend to use these products with equipment or devices which require an extremely high level of reliability and the malfunction of which would directly endanger human life (such as medical instruments, transportation equipment, aerospace machinery, nuclear-reactor controllers, fuel controllers and other safety devices), please be sure to consult with our sales representative in advance.

It is our top priority to supply products with the utmost quality and reliability. However, there is always a chance of failure due to unexpected factors. Therefore, please take into account the derating characteristics and allow for sufficient safety features, such as extra margin, anti-flammability, and fail-safe measures when designing in order to prevent possible accidents that may result in bodily harm or fire caused by component failure. ROHM cannot be held responsible for any damages arising from the use of the products under conditions out of the range of the specifications or due to non-compliance with the NOTES specified in this catalog.

Thank you for your accessing to ROHM product informations.

More detail product informations and catalogs are available, please contact your nearest sales office.

ROHM Customer Support System

THE AMERICAS / EUROPE / ASIA / JAPAN

www.rohm.com

Contact us : webmaster@rohm.co.jp