 Shenzhen Electric Connector Technology CO.,LTD 深圳市电连精密技术有限公司	Product Specification	DOC. No.: 651-0291-01	Rev.: B	Page: 1/14
	P/N: 818000291	Approved/Date	Check/Date	Design/date
		Sam 07/26-12'	Sam 07/26-12'	Hu 07/26-12'

1. Application (应用):

This products are designed for Characteristic measurement in the Mobile phones, W-LAN M, Microwave equipments, etc, application.

该系列产品设计用于移动电话, W-LAN, 其它无线和测量设备等领域电路的特性测量。

2. Scope(范围):

This specification covers the requirements for product performance, test methods and quality assurance provisions of Mini RF III Switch Connectors.

本规范内容包括第三代 Mini RF 开关型同轴连接器的产品性能、测试方法及品质保证方面的要求。

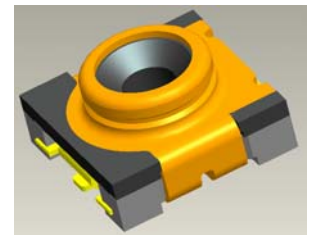

3. Technology Parameters (技术参数)

3.1 Frequency Range(频率范围)	DC~11GHz
3.2 Nominal Characteristic Impedance (特征阻抗)	50 +/-5 Ohm
3.3 Power Rating (额定功率)	2W
3.4 V.S.W.R(电压驻波比)	1.2 Max.(DC~3GHz); 1.3 Max.(3~6GHz); 1.5 Max.(6~11GHz)
3.5 Insertion Loss(插入损耗)-NC State	-0.1dB Max.(DC~3GHz); -0.2dB Max.(3~6GHz); -0.5dB Max.(6~11GHz)
3.6 Isolation(隔离度)-NO State	-20dB Min.(DC~3GHz); -15dB Min.(3~6GHz); -10dB Min.(6~11GHz)
3.7 Operating Temperature Range (工作温度范围)	-40°C ~ +85°C
3.8 Operating Humidity (工作湿度)	95% R.H.MAX

4. Ratings (额定性能要求)

4.1 Voltage Rating (额定电压)	60 VAC (R.M.S)
4.2 Initial Insulation Resistance (绝缘电阻)	500 M Ohm
4.3 Withstand Voltage (耐电压)	300V AC 1 Min.
4.4 Contact Resistance (接触电阻)	
4.4.1 Inner Contact (内导体) (扣除导体电阻) (Without conductor resistance)	70 m ohm Max.
4.4.2 Outer Contact (外导体)	20 m ohm Max.
4.5 Durability(耐久性)	100 Cycles.

5. Compliant Product (可兼容产品)

序号	厂商名称	料号	产品名称/型号	对应测量探针	备注
1	Muruta(村田)	MM8030-2600	带开关同轴连接器 Coaxial Connectors with Switchs	MM126310 或 MXHQ87WA3000	
2	Tyco Electrical 或 TE Connectivity (泰科电子)	1551372-1	微型 Pico 交换同轴连接器 Pico II (Pico Switching Coaxial Connector)	Mass prod.test probe pico switch (PN619361-1)	

ECT Shenzhen Electric Connector Technology CO.,LTD 深圳市电连精密技术有限公司	Product Specification		DOC. No.: 651-0291-01	Rev.: B	Page: 2/14
	P/N: 818000291	Approved/Date	Check/Date	Design/date	
		Sam 07/26-12'	Sam 07/26-12'	Hu 07/26-12'	

6. Electrical Performance(电性性能)

No	Items (项目)	Test Condition (测试条件)	Specifications (规格)
6.1	Contact Resistance (接触电阻)	(EIA 364-23) Testing by the voltage dropping method with the low level current. 按低电平压降方式测量电阻值。 Open circuit voltage/放电压: 20mV MAX Circuit current/电流: 100mA MAX Note:Without Contact Resistance 测试不包括体电阻	Inner contact(中心导体): 70mΩ MAX Ground contact(外导体): 20mΩ MAX
6.2	Insulation Resistance (绝缘电阻)	Mate the plug and receptacle connector together, and then, apply DC 200 V Voltage between the inner contact and the ground contact in accordance with EIA 364-21 按照 EIA364-21,将公母头配合在一起,然后在内导体和拉地端之间施加 200V DC 的电压,然后,进行相关的测试。	Initial(初始值): 500 MΩ MIN After (测试后): 100 MΩ MIN
6.3	Dielectric withstanding voltage (耐电压)	Mate the plug and receptacle connector together, and then apply AC 300 V for 1 minute between the inner contact and the ground contact in accordance with EIA 364-20 按照 EIA364-20 标准,将公母头配合在一起,然后在内导体和接地外导体之间施加 300V AC 的电压持续 1 分钟,并进行相关测试。	No flashover, No sparkover, No excess leakage, No breakdown 无瞬断、熔闪、漏电、击穿。
6.4	V.S.W.R (电压驻波比)	Measure the V.S.W.R as shown in figure 1 by the network analyzer Frequency: DC~11GHz 通过网络分析仪测试 V.S.W.R, 频率范围为 DC~11GHz.如图 1 所示。	1.2 Max. (DC~3GHz); 1.3 Max. (3~6GHz); 1.5 Max. (6~11GHz)

ECT Shenzhen Electric Connector Technology CO.,LTD 深圳市电连精密技术有限公司	Product Specification	DOC. No.: 651-0291-01	Rev.: B	Page: 3/14
	P/N: 818000291	Approved/Date Sam 07/26-12'	Check/Date Sam 07/26-12'	Design/date Hu 07/26-12'

		<p align="center">Figure 1</p> <p align="center">(unit:mm)</p> <p>① Port 1 ④ 818000291 ② SMA Jack ⑤ Port 2 ③ Microstrip line</p>		
6.5	Insertion Loss (插入损耗) -开关 ON 态	Measure the Inertion Loss as shown in figure 2 by the network analyzer Frequency: DC~11GHz 通过网络分析仪测试插损，频率范围为 DC~11GHz.如图 2 所示。	-0.1dBMax. (DC~3GHz); -0.2dBMax. (3~6GHz); -0.5dBMax. (6~11GHz)	
		<p align="center">Figure 2</p> <p align="center">(unit:mm)</p> <p>① Port 1 ④ 818000291 ② SMA Jack ⑤ Port 2 ③ Microstrip line</p>		
6.6	Isolation (隔离度) -开关 OFF 态	Measure the Isolation as shown in figure 3 by the network analyzer Frequency: DC~11GHz 通过网络分析仪测试隔离度，频率范围为 DC~11GHz.如图 3 所示。	20dBMin. (DC~3GHz); 15dBMin. (3~6GHz); 10dBMin. (6~11GHz)	
		<p align="center">Figure3</p> <p align="center">(unit:mm)</p> <p>① Port 1 ④ 818000291 ② SMA Jack ⑤ Temination ③ Microstrip line ⑥ Probe for automatic measurement</p>		

ECT Shenzhen Electric Connector Technology CO.,LTD 深圳市电连精密技术有限公司	Product Specification		DOC. No.: 651-0291-01	Rev.: B	Page: 4/14
	P/N: 818000291	Approved/Date	Check/Date	Design/date	
		Sam 07/26-12'	Sam 07/26-12'	Hu 07/26-12'	

7. Mechanical Performance(机械性能)

No	Items (项目)	Test Condition (测试条件)	Specifications (规格)
7.1	Mating/Un-mating Force (插拔力)	<p>A.Mating Force Measuring the required force for complete mated to the mated connector at 25±3mm/minutes.</p> <p>B.unmating Force Measuring the required force for complete unmating from the mated connector at 25±3mm/minutes.</p> <p>将公母座完全配合到位并测试要求的插入力； 将公母座分离到完全分开位置并测试要求的拔出力， 速率：每分钟 25±3 毫米。</p>	<p>1.Mating Force (插入力): 30N(3Kgf) Max</p> <p>2.Unmating Force (拔出力): 5~30N (0.5~3Kgf)</p>
7.2	Allowed Push Foce (允许的推压力)	<p>The connector is soldered on the test PCB and then push the switch of the connector from on-state to off-state by a test probe as shown in Figure 4 with the required force along the axis direction,which is needed to get 15dB isolation at 6GHz is measured.</p> <p>如图 4 所示，通过测试探针以轴向力下压连接器开关的动弹片使开关完全断开,当 6GHz 频点所对应的隔离度达到 15dB 时,测试所施加的力。</p>	2.0~4.5N (0.20~0.45Kgf)

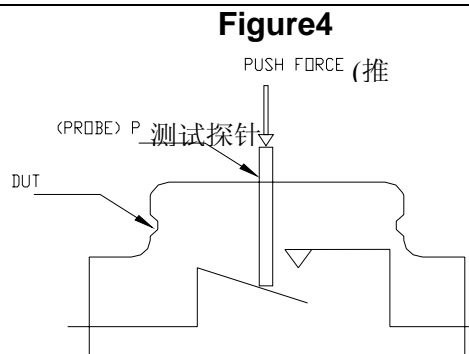

ECT Shenzhen Electric Connector Technology CO.,LTD 深圳市电连精密技术有限公司	Product Specification		DOC. No.: 651-0291-01	Rev.: B	Page: 5/14
	P/N: 818000291	Approved/Date	Check/Date	Design/date	
		Sam 07/26-12'	Sam 07/26-12'	Hu 07/26-12'	

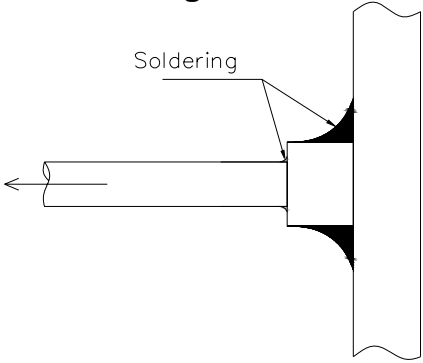
	7.3	Durability (机械寿命)	<p>Mate and un-mate the receptacle connector(soldered to the test board) and plug connector 100 cycles at the speed of 25 ± 3 mm/minutes along the mating direction by the push-push machine</p> <p>将母座焊接在测试板上，然后，通过插拔力测试仪沿配合方向以每分钟 25 ± 3 毫米的速度插拔公母头 100 个循环，然后测试参数。</p>	<p>Appearance: No abnormality</p> <p>Contact Resistance: Shall meet 6.1</p> <p>外观：无损伤</p> <p>接触电阻：满足节 6.1 要求</p>
	7.4	Adhered of Electrode Terminal (焊点粘接力)	<p>Soldering test sample with test PCB. Measure Recording to figure 5 under condition as following.</p> <p>将产品焊在 PCB 上,按图 5 方式在下述条件下测量:</p> <p>1. Force(拉力):40N 2.Time(时间):5+/-1s.</p>	No excoriation of electrode terminal 端子焊点无损伤。
	<p>Figure 5</p> 			
7.5	Vibration (振动)	<p>Apply the following vibration to the mating connector.</p> <p>During the testing,run 100mA DC to check electrical discontinuity.</p> <p>Frequency:10Hz → 100Hz→30Hz/approx 20minutes.</p> <p>Half amplitude,Peak value of acceleration: 3mm or 60m/s^2 (6G)</p> <p>Directions,cycle:3 mutually perpendicular direction,3 cycles about each direction</p> <p>将公母头配合，并施加如下条件测试。在测试期间,施加 100mA DC 电压,并检验电不连续性。</p> <p>频率：10Hz → 100Hz → 10Hz/约 20minutes.</p> <p>半振幅、加速度：3mm、60m/s^2 (6G)</p> <p>方向和循环次数：每个互相垂直方向上进行 3 次测量。</p>	<p>Appearance:No abnormality</p> <p>Contact Res.:Shall meet 6.1</p> <p>Nodiscontinuities of $10\ \mu\text{s}$ or longer duration</p> <p>外观：无损伤</p> <p>接触电阻：满足节 6.1 的要求，电不连续性不超过 $10\ \mu\text{s}$。</p>	

 Shenzhen Electric Connector Technology CO.,LTD 深圳市电连精密技术有限公司	Product Specification		DOC. No.: 651-0291-01	Rev.: B	Page: 6/14
	P/N: 818000291	Approved/Date	Check/Date	Design/date	
		Sam 07/26-12'	Sam 07/26-12'	Hu 07/26-12'	

7.6	Shock (机械冲击)	<p>EIA 364-27 Condition A</p> <p>The object of this test procedure is to detail a standard method to assess the ability of a connector to withstand specified severity of mechanical shock. Test Current:100mA.</p> <p>此测试程序的目的是要作一详细标准以评估连接器能承受特定严格机械冲击的能力。</p> <p>Peak value of acceleration:750m/s² (75G)</p> <p>Duration :6ms</p> <p>Wave form : half sinusoidal</p> <p>Directions,cycle : 6 mutually perpendicular direction, 3cycles about each direction</p> <p>振幅峰值, :750m/s² (75G)</p> <p>持续时间: 6 毫秒</p> <p>波型: 半正弦波</p> <p>方向和循环次数: 每 6 个相互垂直方向上各进次 3 次。通电 100mA 测试电不连续性。</p>	<p>Appearance: No abnormality</p> <p>Contact Res.: Shall meet 6.1</p> <p>No discontinuities of 10 μ s or longer duration</p> <p>外观: 无损伤</p> <p>接触电阻: 满足节 6.1 要求</p> <p>电不连续性不超过 10 μ s</p>
-----	-----------------	---	--

8. Environmental Performance(环境性能)

No	Items (项目)	Test Condition (测试条件)	Specifications (规格)
8.1	Humidity (湿度试验)	<p>Test is done without mating adaptor ,apply the following environment to the mating connector in accordance with MIL-STD-202, Method 103Test Condition B</p> <p>Temperature : 60°C</p> <p>Humidity : 95%R.H</p> <p>Duration: 96 hours(50hours*)</p> <p>Note: The condition is under the “*”value when test is done with adaptor.</p> <p>Measurements should be done within 2hours.</p> <p>在未用转接器插合状态下, 根据 MIL-STD-202 试验条件 B 中的第 103 方法,对已配合的连接器施加下列条件测试.</p> <p>温度: 60°C</p> <p>湿度: 95%R.H</p> <p>持续时间: 96 小时(50 小时*)</p> <p>备注: 1)在有转接器插合状态下测试时间为“*”值。2) 所有测量应在完成湿度试验 2 小时内进行。</p>	<p>Appearance: No abnormality</p> <p>Contact Resistance: Shall meet 6.1</p> <p>Insulation Resistance: Shall meet 6.2</p> <p>Dielectric withstanding voltage Shall meet 6.3</p> <p>外观: 无损伤</p> <p>接触电阻: 满足 6.1</p> <p>绝缘电阻: 满足 6.2</p> <p>耐电压: 满足 6.3</p>

 Shenzhen Electric Connector Technology CO.,LTD 深圳市电连精密技术有限公司		Product Specification		DOC. No.: 651-0291-01	Rev.: B	Page: 7/14
		P/N:		Approved/Date	Check/Date	Design/date
		818000291		Sam 07/26-12'	Sam 07/26-12'	Hu 07/26-12'
	8.2	Thermal Shock (冷热冲击)	Apply the following environment to the mating connector in accordance with MIL-STD-202, Method 107 Test Condition : -50°C (30min) ~ 25°C (5max) ~ 90°C (30min) ~ 25°C (5max) Transition time: : 5min. MAX Cycles: 50 Cycles 根据 MIL-STD-202, 按如下试验条件对已配合的连接器施加下列条件测试. 循环: -50°C (30min) ~ 25°C (5max) ~ 90°C (30min) ~ 25°C (5max) 转换时间: 5 min Max. 循环次数: 50 次数	Appearance: No abnormality Contact Resistance: Shall meet 6.1 Insulation Resistance: Shall meet 6.2 Dielectric withstanding voltage Shall meet 6.3 外观: 无损伤 接触电阻: 满足节 6.1 中的要求 绝缘电阻: 满足节 6.2 中的要求 耐电压: 满足节 6.3 中的要求		
	8.3	solderability (可焊试验)	Apply the following environment to the mating connector Temperature : 245 ± 5°C Duration : 3~5 second Test sample should be observed by the magnification of 10times after the test. 按下列条件对已配合的连接器进行测试. 温度: 245+/-5°C 持续时间: 3~5 秒钟. 观测: 10 倍放大镜	At least 95% covered by a continuous new solder coating. 吃锡面积大于 95% 以上。		
		Resistance to soldering heat (耐焊接热试验)	Apply the following environment to the mating connector Temperature : 260 ± 2°C Duration : 3+/-5%min 按下列条件对已配合的连接器进行测试. 温度: 260+/-2°C 持续时间: 3+/-5%分钟.	Appearance: No abnormality Coplanarity of the solder tail should be not beyond 0.10mm 外观无明显损伤, 焊脚平面度不超过 0.10mm.		

P/N:

818000291

Approved/Date

Sam
07/26-12'

Check/Date

Sam
07/26-12'

Design/date

Hu
07/26-12'

8.4

Salt Spray
(盐雾测试)

EIA 364-26 Test Condition A
Apply the following environment to the mating connector
Temperature : $35 \pm 2^{\circ}\text{C}$
Relative Humidity : 90~98%R.H
Salt water density: $5 \pm 1\%$
Duration : 48 hours for contact area
根据 EIA364-26 试验条件 A 中的要求,,对已配合的连接器施加下列条件测试.
温度: $35 \pm 2^{\circ}\text{C}$
相对湿度: 90~98%R.H
盐水浓度: $5 \pm 1\%$
持续时间: 48 hours

Appearance: No abnormality
Contact Resistance: Shall meet 6.1
外观: 无损伤
接触电阻: 满足节 6.1 中的要求

9. Profile Dimensions(外形规格)

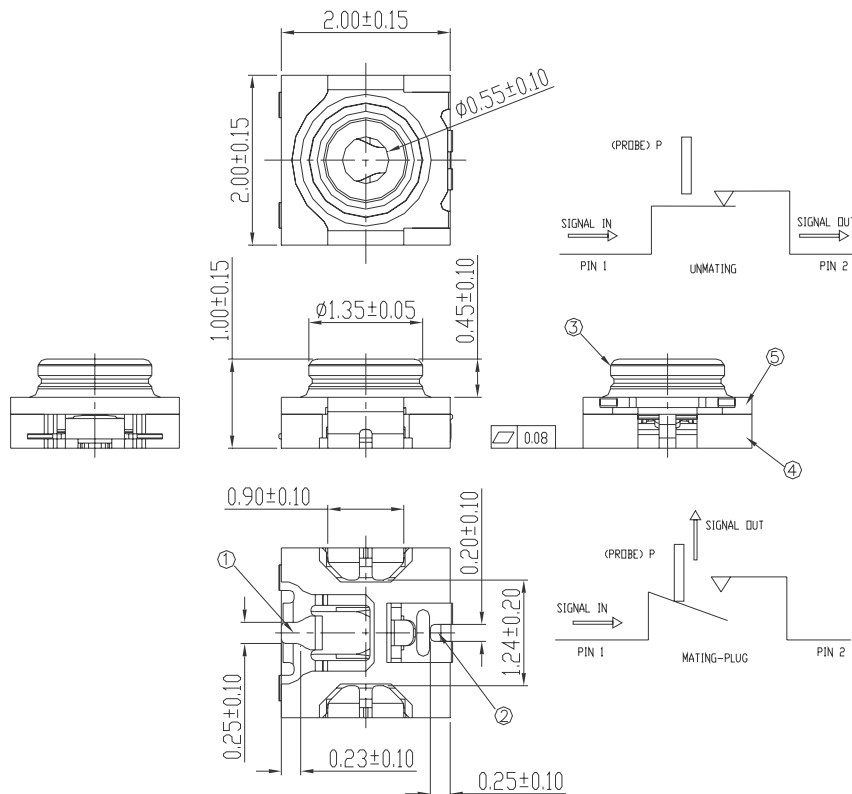

⑤	1	TOP HOUSING	Hight Temp. Plastic UL94V-0/BLACK
④	1	BODY HOUSING	Hight Temp. Plastic UL94V-0/BLACK
③	1	SHELL	Copper Alloy/Au Plated Over Ni
②	1	PIN 2	Stainless Steel/Au Plated Over Ni
①	1	PIN 1	Stainless Steel/Au Plated Over Ni
ITEM	Q'TY	DESCRIPTION	MATERIAL/FINISH
BOM LIST			

ECT Shenzhen Electric Connector Technology CO.,LTD 深圳市电连精密技术有限公司	Product Specification	DOC. No.: 651-0291-01	Rev.: B	Page: 9/14
	P/N: 818000291	Approved/Date Sam 07/26-12'	Check/Date Sam 07/26-12'	Design/date Hu 07/26-12'

10.Recommanded PCB LAYOUT And METAL MASK(推荐的 PCB 安装焊盘及钢网规格)

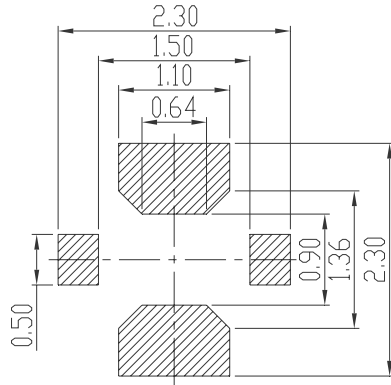

Recommend PCB Layout
General Tolerance: ±0.05

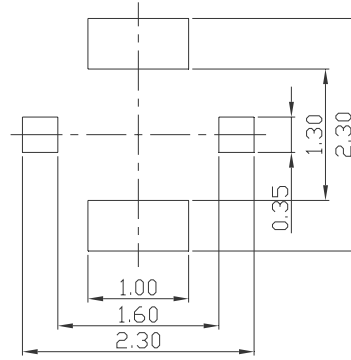

RECOMMENDED METAL MASK
THICKNESS 0.12MM

11. Recommanded Reflow Soldering Condition(SMT 温度曲线图)

11.1 Recommanded Temp.&Time of Reflow Soldering
建议回流焊温度与时间条件

11.2 Reflow Soldering Standard Condtions
回流焊极限温度与时间条件

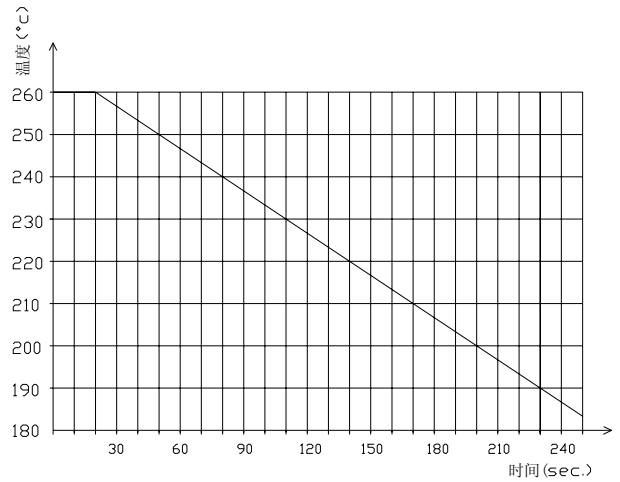
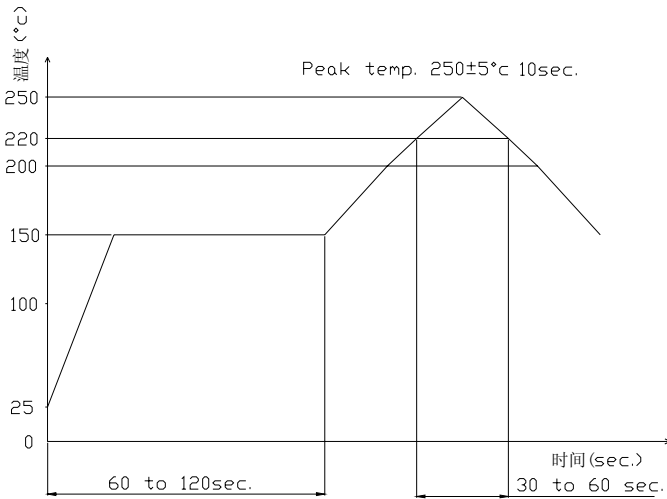

ECTShenzhen Electric Connector
Technology CO.,LTD
深圳市电连精密技术有限公司**Product
Specification**

DOC. No.: 651-0291-01

Rev.: B

Page: 10/14

P/N:

818000291

Approved/Date

Sam
07/26-12'

Check/Date

Sam
07/26-12'

Design/date

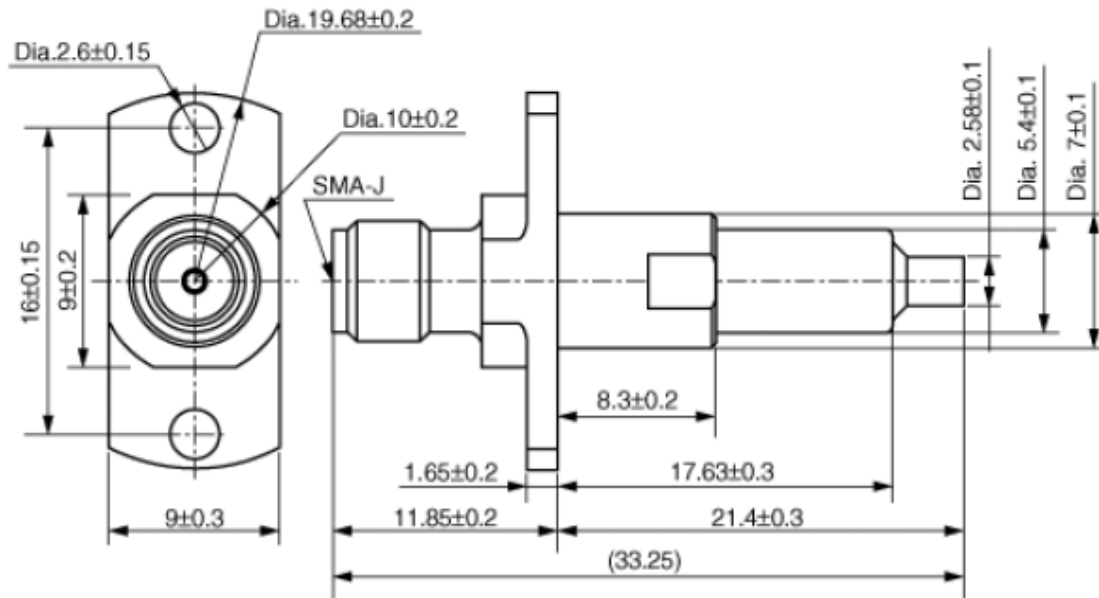
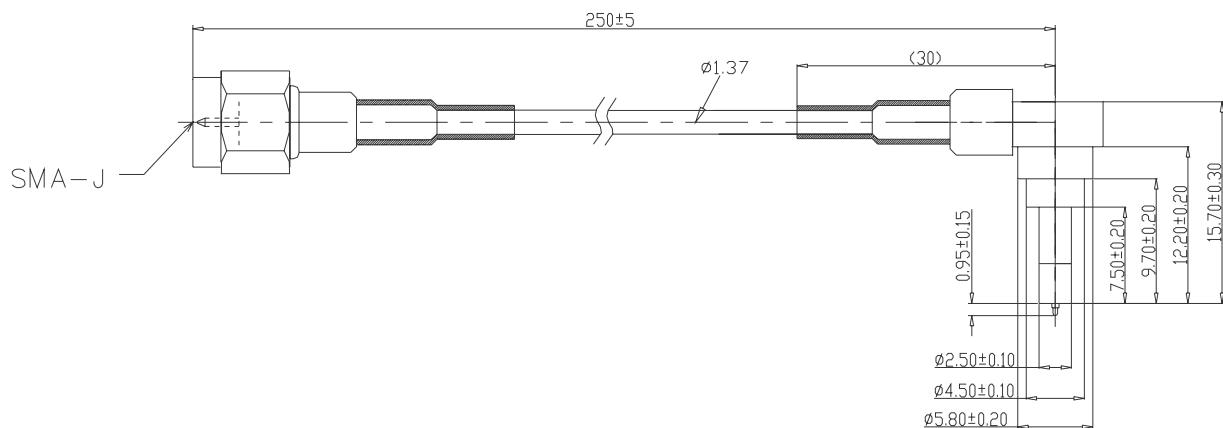
Hu
07/26-12'**12.Recommanded Mating test Probe(推荐的测试探针)****Type A:****Type B:**

ECT Shenzhen Electric Connector Technology CO.,LTD 深圳市电连精密技术有限公司	Product Specification	DOC. No.: 651-0291-01	Rev.: B	Page: 11/14
	P/N: 818000291	Approved/Date Sam 07/26-12'	Check/Date Sam 07/26-12'	Design/date Hu 07/26-12'

13.Packaging (包装)

13.1 上带的剥离力度：300mm/min 的速度进行剥离，力度最大应该是 1.3N

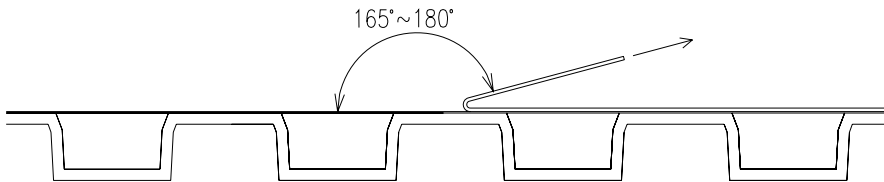

13.2 包装方式：载带包装，3000Pcs/卷 (Φ178mm)

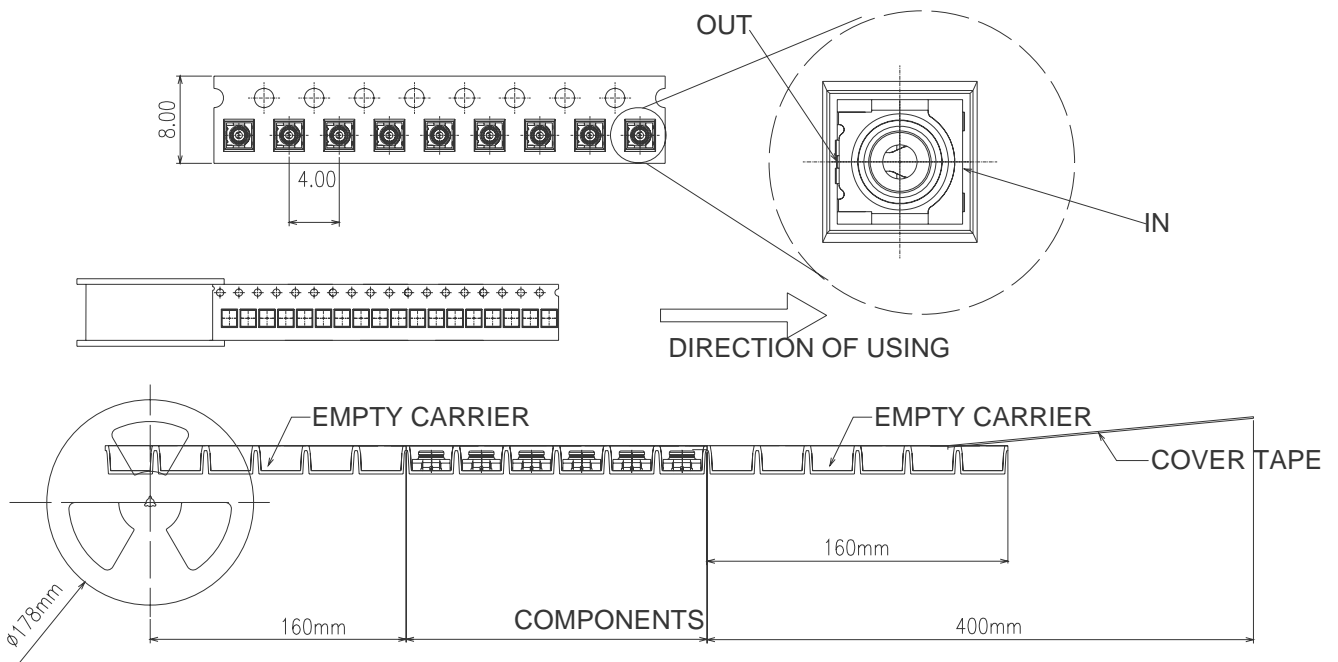

 Shenzhen Electric Connector Technology CO.,LTD 深圳市电连精密技术有限公司	Product Specification		DOC. No.: 651-0291-01	Rev.: B	Page: 12/14
	P/N: 818000291	Approved/Date	Check/Date	Design/date	
		Sam 07/26-12'	Sam 07/26-12'	Hu 07/26-12'	

14. Usage Precaution (使用禁忌或注意事项)

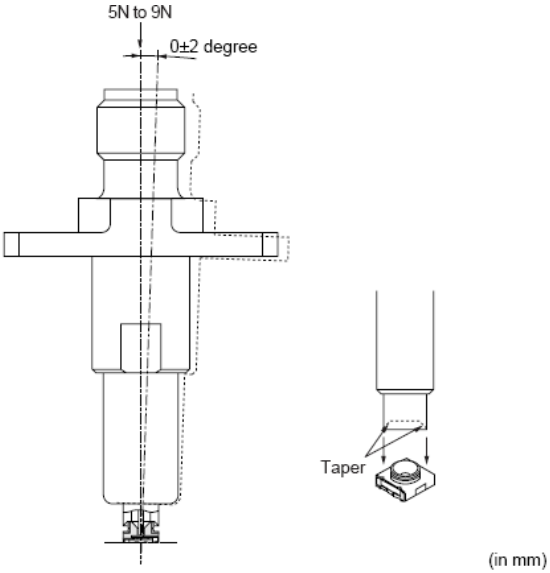
No	Items (项目)	Test Condition (测试条件)	Specifications (规格)
14.1	(1) Connection/ disconnection of connectors 连接器的连接 和断开	<p>1).To mate the connectors, the mating axis of both connectors must be aligned and the connectors can be mated fully, until they can't be moved. Not allowed in a very tilt mating angle and do not bend coaxial cable in the measuring procedure, otherwise you'll get a not good test data.</p> <p>1).公母头连接器进行配合前,务必确保两者对齐,对插到死点位置为止,表示两者已完全配合在一起,不要以极偏的角度插配连接器,测试使用过程中,请不要将同轴线折弯,否则可能会影响测试效果。</p> <p>2).To disconnect connectors, pls disengage them along the axis direction of mating hole,until they're separated completely.</p> <p>2) 断开时请尽量沿配合开口的轴向方向竖直拔起线端公头直至两者完全脱离为止。</p> <p>允许的配合角度和施加力如图 6.</p>	
		<p>Figure 6</p> <p style="text-align: center;">Type A:</p> 	

ECT Shenzhen Electric Connector Technology CO.,LTD 深圳市电连精密技术有限公司	Product Specification		DOC. No.: 651-0291-01	Rev.: B	Page: 13/14
	P/N: 818000291	Approved/Date	Check/Date	Design/date	
		Sam 07/26-12'	Sam 07/26-12'	Hu 07/26-12'	

Type B:

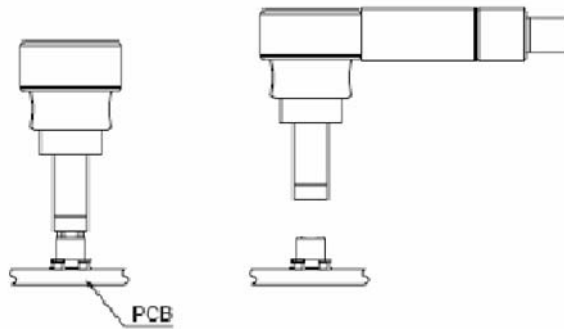

14.2	Precautions (禁忌)	<p>Pls mount this product at the position so that stress by wrap and/or bend of the pcb may not apply to it.产品安装位置处不应有PCB 翘曲和/或弯曲施加应力.</p> <p>Pls avoid the cleaning of this product 请避免清洁此产品.</p>	
14.3	Stockpile condition (存储条件)	<p>Use this product within 6 months after receipt 有效期: 请在产品接收后的 6 个月内使用</p> <p>Condition : Temp: -10~+40℃ Humidity:15~85%</p> <p>存储环境: 温度:-10~+40℃; 湿度:15%~85%</p>	

 Shenzhen Electric Connector Technology CO.,LTD 深圳市电连精密技术有限公司	Product Specification			DOC. No.: 651-0291-01	Rev.: B	Page: 14/14
	P/N: 818000291			Approved/Date	Check/Date	Design/date
				Sam 07/26-12'	Sam 07/26-12'	Hu 07/26-12'

15. Test Sequence and Sample Quantity(测试顺序及样品数量)

Test Item (测试项目)	Group (测试分组)											
	A	B	C	D	E	F	G	H	I	J	K	L
Examination of product (外观检测)	1,11	1,	1,3	1,	1,	1,6	1,	1,3	1,3	1,5		
Contact Resistance (接触电阻)	2,12			2,4	2,4	2,7	2,7			2,4		
Insulation Resistance (绝缘电阻)	3,					3,8	3,8					
Dielectric Withstanding Voltage (耐电压)	4,					4,9	4,9					
V.S.W.R (电压驻波比)	5,13											
Insertion Loss (插入损耗)	6,14	1,										
Isolation (隔离度)	7,15											
Mating/un-mating Force (插拔力)	8,10											
Allowed Push Force (接触压力)		2,4										
Durability (机械寿命)	9,	3,										
Adhered of Electrode Terminal (焊点粘接力)			2,									
Vibration (振动)				3,								
Shock (冲击)					3,							
Humidity (湿度试验)						5,						
Thermal Shock (冷热冲击)							5,					
Solderability (可焊性)								2,				
Resist.to soldering heat (耐焊接热试验)									2,			
Salt Spray (盐雾测试)										3,		
Sample QTY(PCS) 样品数量	5	5	5	5	5	5	5	5	5	5	5	5

The number of group is test sequence 测试分组中的序号为试验顺序。