

REV.	DESCRIPTION	ECN NO.	DATE	DRAWER

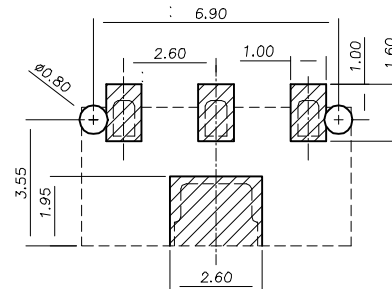
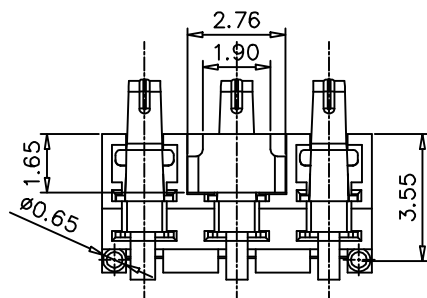
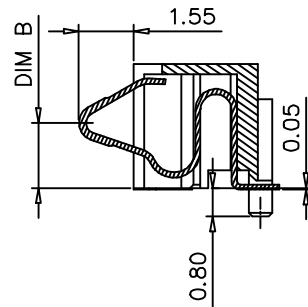
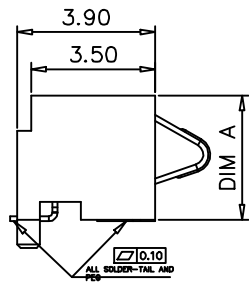
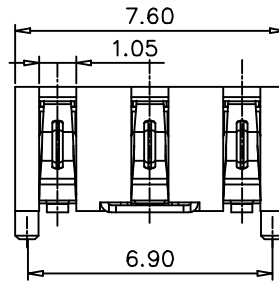
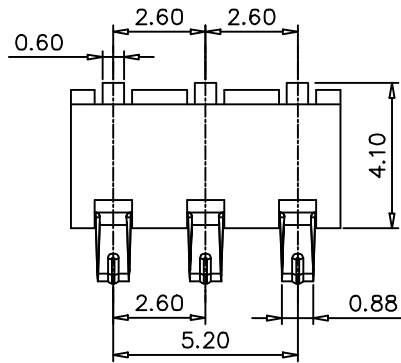

RECOMMENDED PCB LAYOUT
TOP VIEW (XX±0.05)

NOTES:

A.Material:

- 1.Insulator:Highperature thermoplastic UL94V,(BLACK LCP)
- 2.Material:C17200,plating,Selective gold 3u"Contact over , on solder area gold 1u",all nickel

B.Electrical specifications:

- Voltage rating:250 VAC min
- Current rating:2.0A min
- Dielectric strength:1000V AC for 1 minute min
- Insulation resistance:1000 meg ohm min
- Contact resistance:30 mill,ohm max
- Operation temperature:-55C to+125C
- Product withstanding rff low soldering 260C for 15s

C.Mechanical speieications:

- 3.1 Durability:3500 cycles
- 3.2 Normal force at working position:120g min

PART NUMBER

WD-03153M-BX1-XX

镀金厚度 0-FU
1- 3u" 2-6u"
3-15u" 4-30u"
5-50u"

规格	A	B
WD-03153M-BX1-40	4.00	2.30
WD-03153M-BX1-35	3.50	1.90

DIMENSION IN mm [inch]		东莞市伟定电子有限公司	
Tolerance unless otherwise specified		TEL: 0769-88925318 FAX: 0769-89221023	
X. ± --	X.* ± 10'	ITEM : 2.6mm SMT 3P 电池座	
XX ± 0.38	XX.* ± 5'		
XXX ± 0.25	XXX.* ± 2'	PART NO:WD-03153M-BX1-XX	Scale: 1 : 1
XXX ± 0.13	XXX.* ± --	DRAW NO:WD-03153M-BX1-XX	Size: A 4
Appover: JEERY		Checker: ANDY	Drawer: CHRIS
		2015/04/02	
		Sheet: 1 / 1	