

Features

- Lead free and Green Device Available
- Low Rds-on to Minimize Conductive Loss
- High avalanche Current

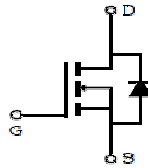

V_{DSS}	30V
R_{DS(on)} V_{GS}=10V typ.	4.3mΩ
max.	5.5mΩ
R_{DS(on)} V_{GS}=4.5V typ.	6.3mΩ
max.	7.5mΩ
I_D @ V_{GS}=10V (Silicon limited)	100A
I_D @ V_{GS}=10V (Package limited)	80A

Application

- Load Switch
- SPMS

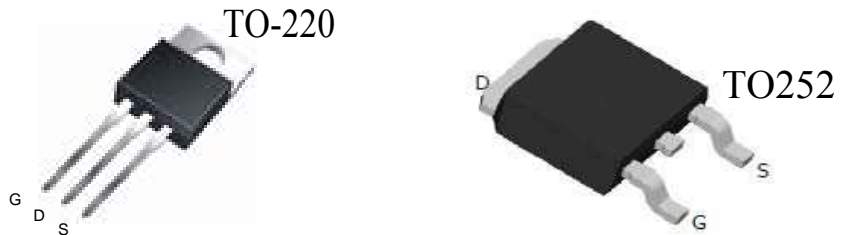

1.Gate 2. Drain 3. Source

Absolute Maximum Ratings (T_A=25°C unless otherwise noted)

Symbol	Param	Maximum	Unit	
V _{DSS}	Drain-to-Source Voltage	30	V	
V _{GSS}	Gate-to-Source Voltage	±20	V	
I _D V _{GS} =10V	Continuous Drain Current	T _C =25°C (Silicon limited)	100	A
		T _C =100°C (Silicon limited)	80	
I _D V _{GS} =4.5V		T _C =25°C (Package limited)	70	
		T _C =25°C (Silicon limited)	100	
		T _C =100°C (Silicon limited)	65	
		T _C =25°C (Package limited)	70	
I _{DP}	Pulsed Drain Current	T _C =25°C	-	A
I _{AS}	Avalanche Current (L=0.1mH)		23	A
E _{AS}	Avalanche Energy (L=0.1mH)		26	mJ
P _D	Maximum Power Dissipation	T _C =25°C	71	W
		T _C =100°C	35	
T _J , T _{STG}	Junction & Storage Temperature Range		-55~175	°C

Thermal Characteristics

Symbol	Parameter	Max.	Unit
R _{thJC}	Thermal resistance, junction to case	2.1	°C/W
R _{thJA}	Thermal resistance, junction to ambient	106	°C/W

Electrical Characteristics (TA=25°C unless otherwise noted)

Symbol	Parameter	Test Conditions	Min.	Typ	Max.	Unit
Static Characteristics						
BV_{DSS}	Drain-Source Breakdown Voltage	$V_{GS}=0V, I_D=250\mu A$	30	—	—	V
I_{DSS}	Zero Gate Voltage Drain Current	$V_{DS}=30V, V_{GS}=0V$	—	—	1	μA
$V_{GS(th)}$	Gate Threshold Voltage	$V_{DS}=V_{GS}, I_D=250\mu A$	0.8	—	1.8	V
I_{GSS}	Gate Leakage Current	$V_{GS}=\pm 20V, V_{DS}=0V$	—	—	± 100	nA
$R_{DS(on)}$	Drain-Source On-Resistance	$V_{GS}=10V, I_D=25A$	—	5.3	6.5	m Ω
		$V_{GS}=4.5V, I_D=20A$	—	6.2	8	
G_{fs}	Forward Transconductance	$V_{DS}=5V, I_D=100A$	—	72	—	S
Diode Characteristics						
V_{SD}	Diode Forward Voltage	$I_{SD}=25A, V_{GS}=0V$	—	0.8	1.3	V
I_S	Diode Continuous Forward Current		—	—	50	A
t_{rr}	Reverse Recovery Time	$I_S=20A,$ $di/dt=100A/\mu s$	—	14	—	nS
Q_{rr}	Reverse Recovery Charge		—	2.8	—	nC
Dynamic Characteristics						
R_G	Gate Resistance	$V_{GS}=0V, V_{DS}=0V,$ Frequency=1MHz	—	1.9	—	Ω
C_{iss}	Input Capacitance	$V_{GS}=0V,$ $V_{DS}=15V,$ F=1MHz	—	2999	—	pF
C_{oss}	Output Capacitance		—	335	—	
C_{rss}	Reverse Transfer Capacitance		—	290	—	
$t_{d(on)}$	Turn-On Delay Time	$V_{DS}=15V,$ $I_D=1A,$ $R_g=3\ \Omega,$ $V_{GS}=4.5V$	—	21	—	nS
t_r	Rise Time		—	32	—	
$t_{d(off)}$	Turn-Off Delay Time		—	59	—	
t_f	Fall Time		—	34	—	
Gate Charge Characteristics						
Q_g	Total Gate Charge	$V_{DS}=25V,$ $V_{GS}=4.5V,$ $I_D=14A$	—	26	—	nC
Q_{gs}	Gate-to-Source Charge		—	3.5	—	
Q_{gd}	Gate-to-Drain Charge		—	14	—	

Typical Operating Characteristics

Figure 1. Typ. Output Characteristics

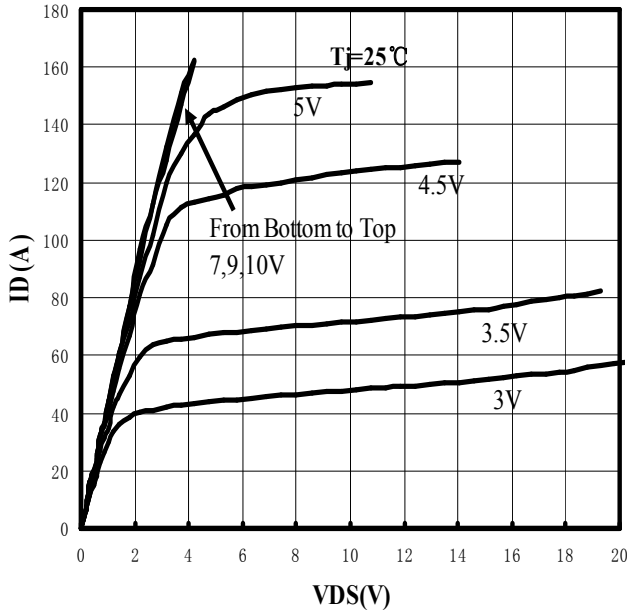

Figure 2. Typ. Output Characteristics

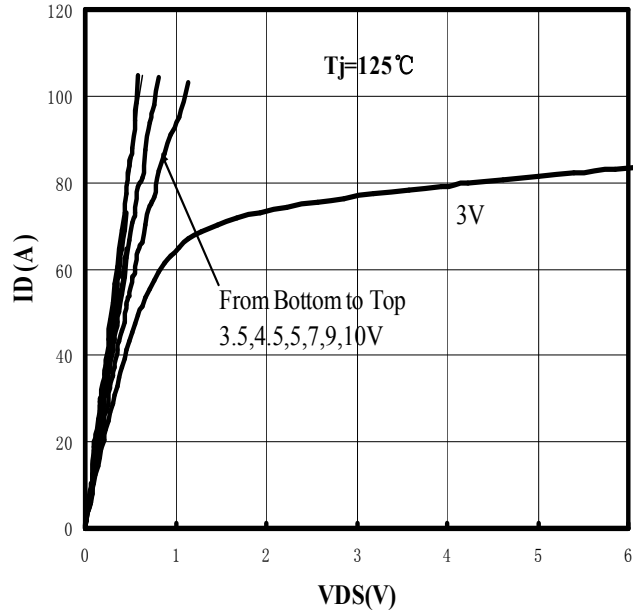

Figure 3. Transfer Characteristics

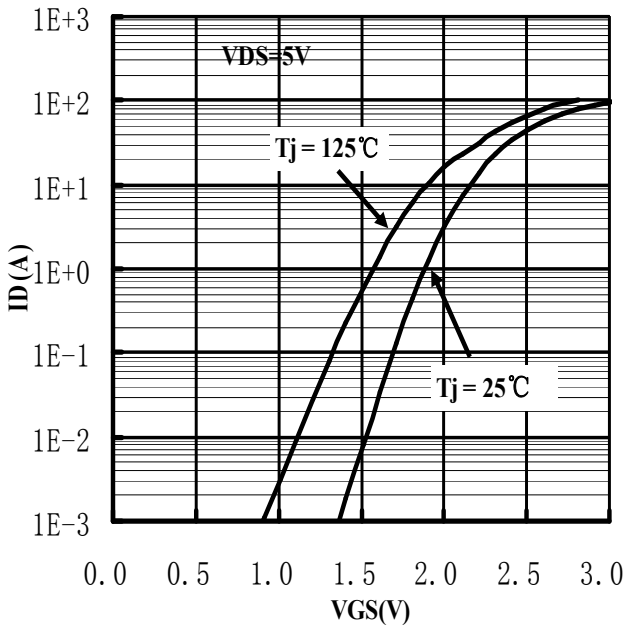
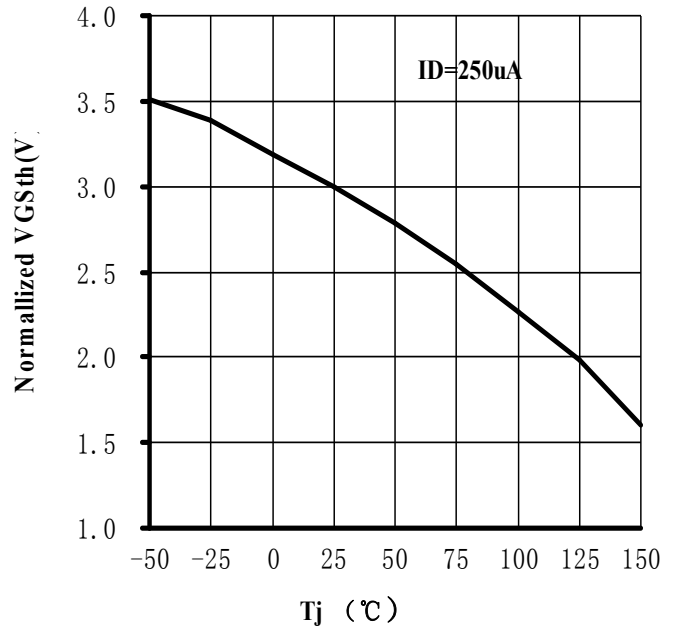

Figure 4. Gate Threshold Voltage Characteristics



Typical Operating Characteristics

Figure 5. Rdson vs. Drain Current Characteristics

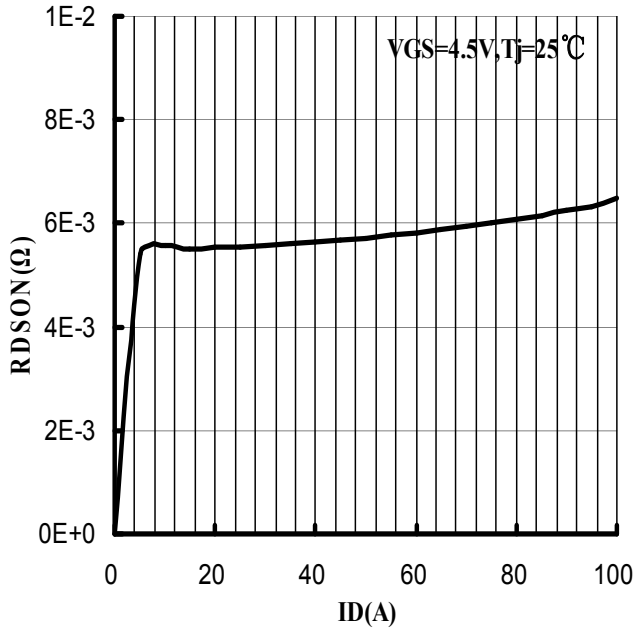

Figure 6. Rdson vs. Junction Tem Characteristics

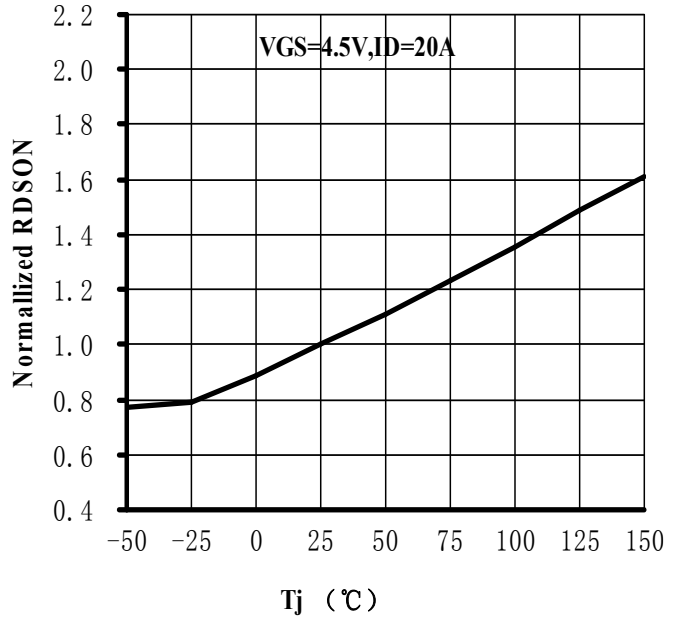

Figure 7. Rdson vs. VGS Characteristics

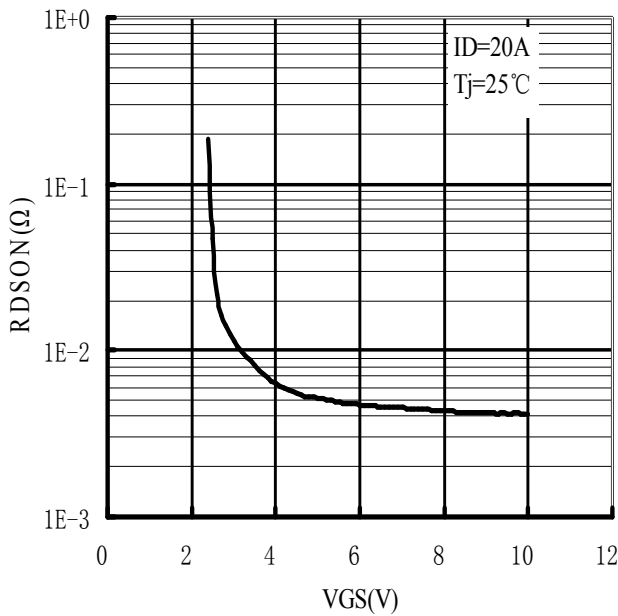
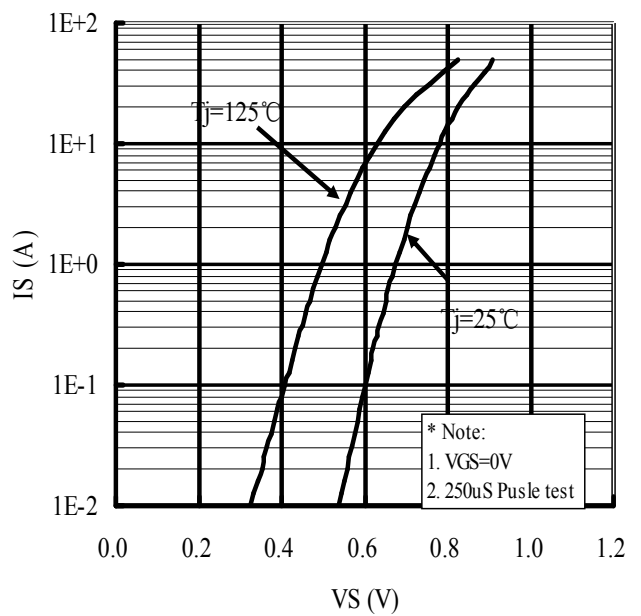

Figure 8. IS vs. VSD Characteristics



Typical Operating Characteristics

Figure 9. Gate Charge Characteristics

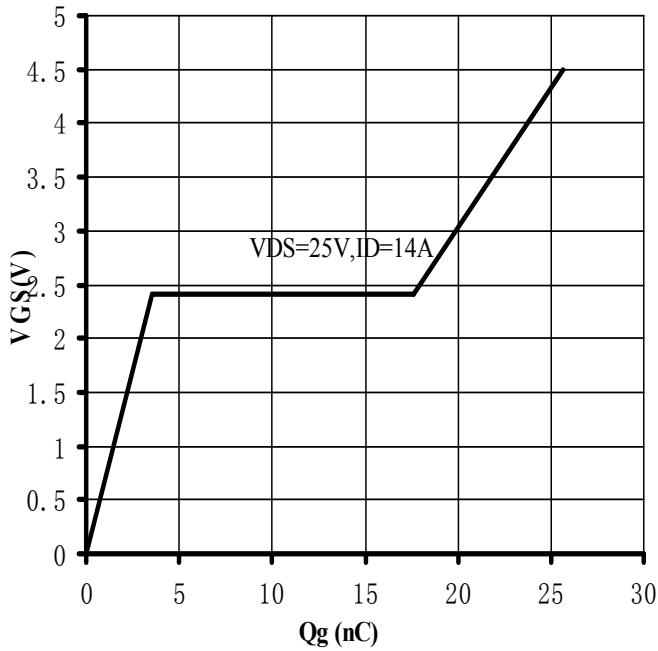

Figure 10. Capacitance Characteristics

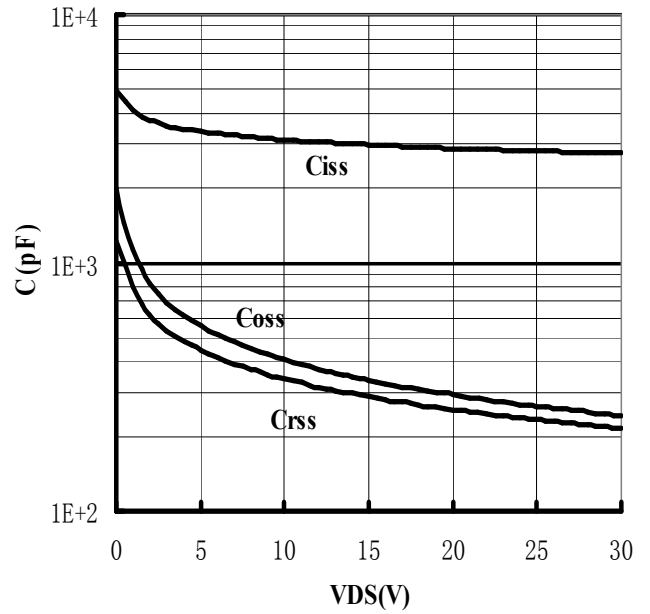
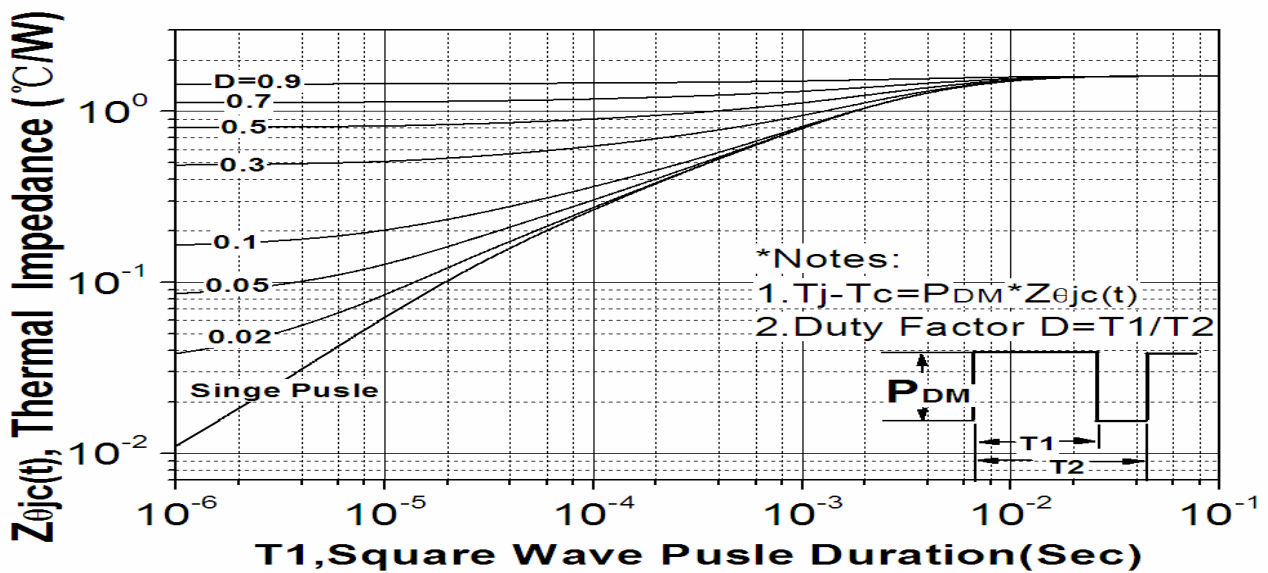
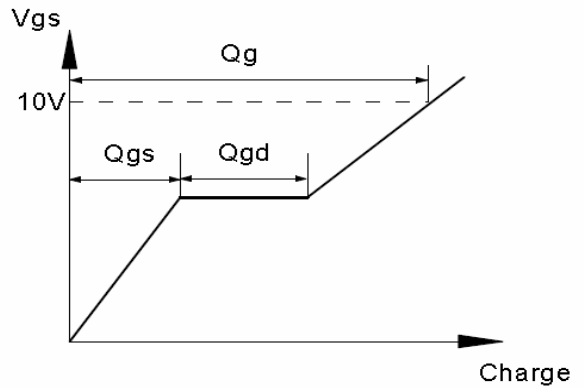
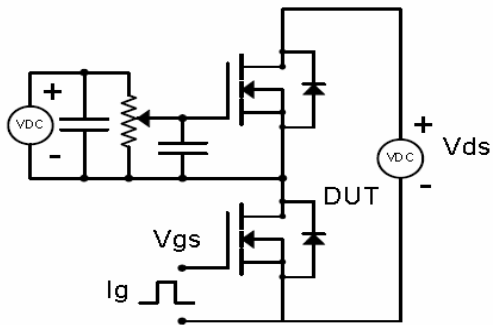

Figure 11. Thermal Resistance Characteristics



Test Circuit & Waveform

Gate Charge Test Circuit & Waveform



Resistive Switching Test Circuit & Waveforms

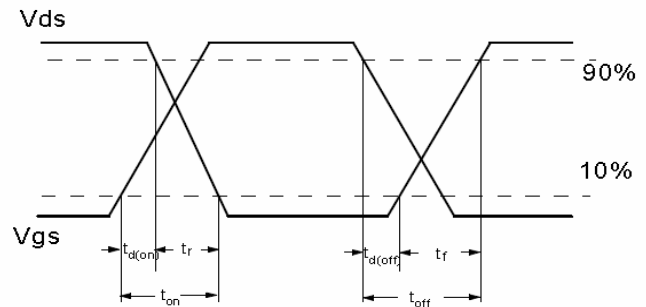
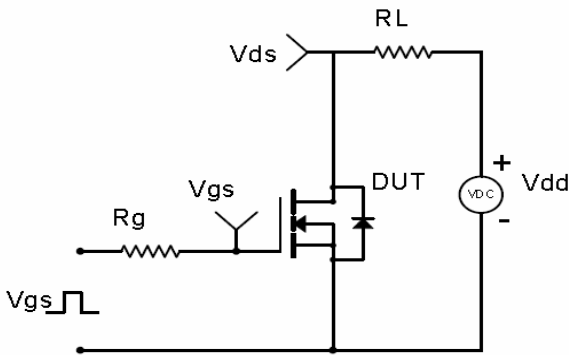

Unclamped Inductive Switching (UIS) Test Circuit & Waveforms

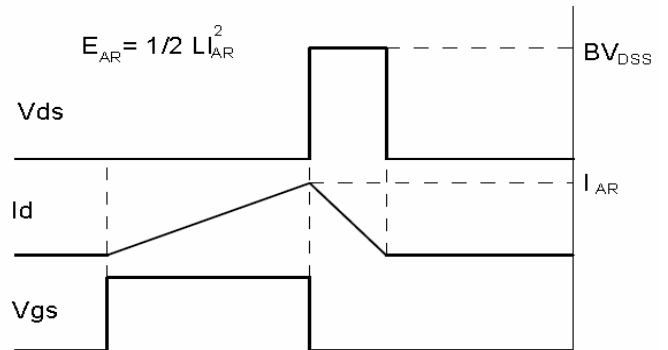
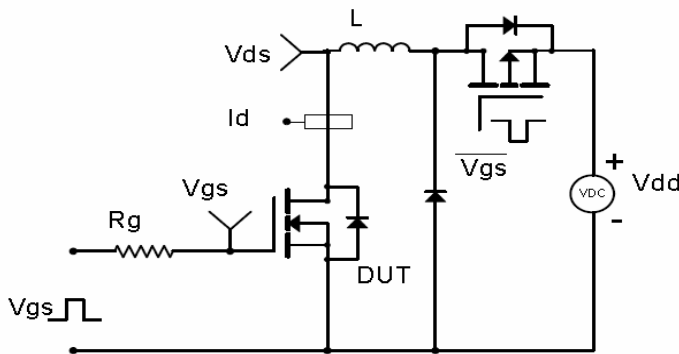

Diode Recovery Test Circuit & Waveforms

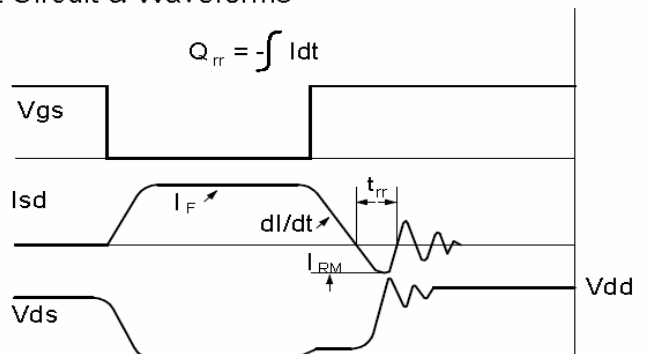
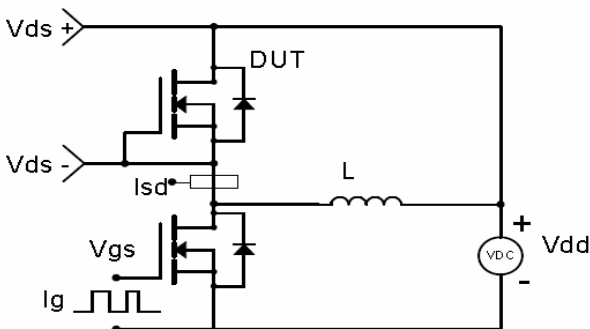

Package Information

TO-252

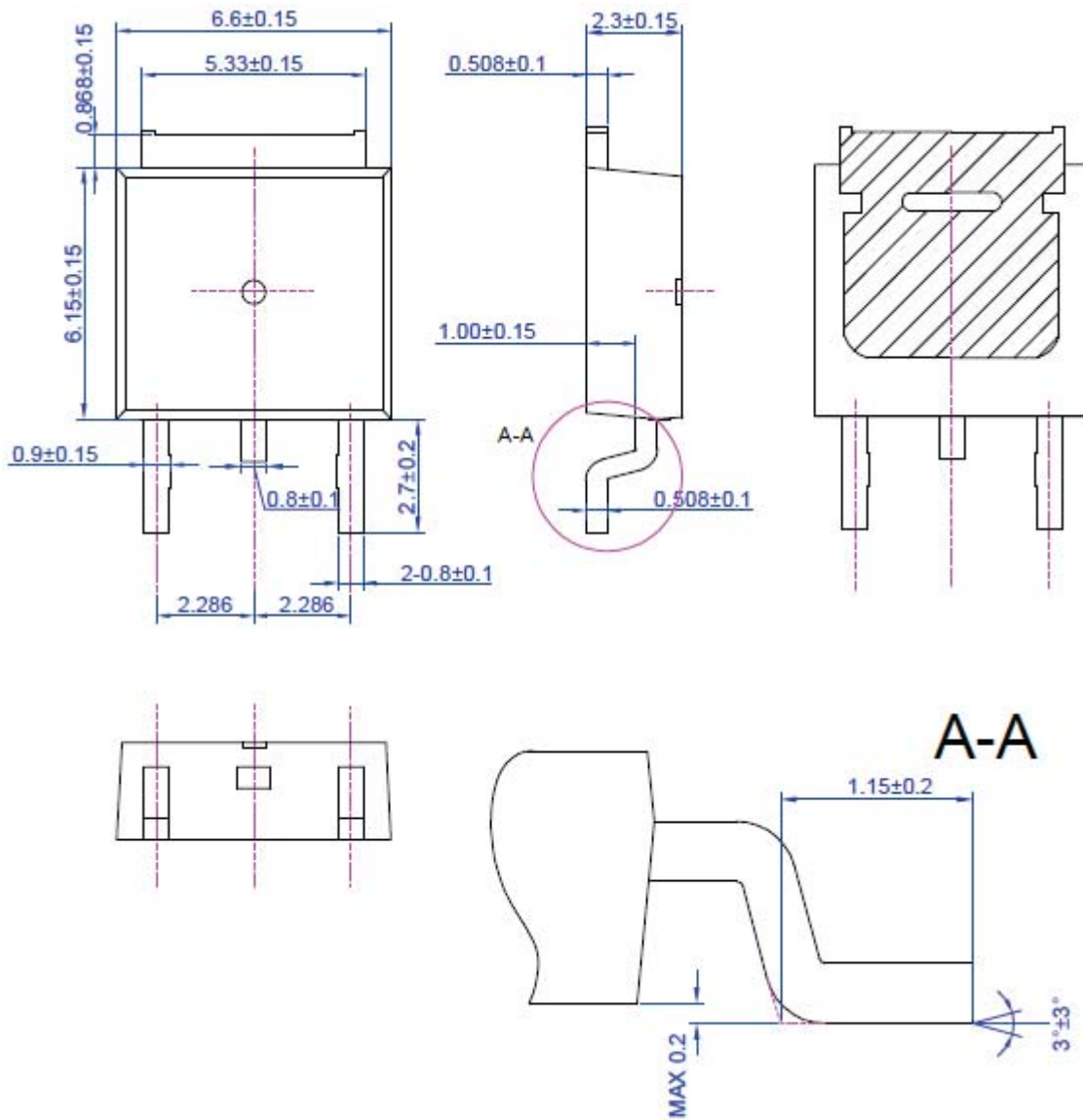

Package Information

TO-220 (B)

