

TABLE OF CONTENTS

NL SERIES 12VIN DC / DC CONVERTERS

NL50S

SINGLE OUTPUT, 50 WATTS.....2

NL100

SINGLE AND DUAL OUTPUT, 100 WATTS.....4

NL150

SINGLE AND TRIPLE OUTPUT, 150 WATTS.....6

ACCESSORY PRODUCTS (EMI FILTERS)

NLF50

50 WATT MAX CAPABILITY.....8

NLF150

150 WATT MAX CAPABILITY.....9

PERFORMANCE CHARACTERISTICS.....10

GUIDE TO OPERATION.....11

APPLICATION NOTES.....14

BLOCK DIAGRAM.....23

FREQUENTLY ASKED QUESTIONS.....24

NL50

50 Watts Output Power

SINGLE OUTPUT



How to Order:

NL	50	S	M	/	5	-	A	-	D
Series	Total Output Power	Single Output	Industrial (I) or Military (M)	Output Voltage: Maximum current as stated in chart	Options: A- pins out side of unit B- pins out bottom of unit C- pins out top of unit D- through hole inserts (STD threaded) I - M2.5 inserts				

INPUT CHARACTERISTICS

	PER CHANNEL			Units
	Min.	Typ.	Max.	
Input Voltage	9	12	18	Vdc
Brown Out (75% of Full Load) [fig. I]*		7		Vdc
No Load Power Dissipation		1	2	Watt
Inrush Charge [fig. VII]*			3.5	mc
Reflective Ripple Current [fig. VIII]*		3		%
Logic Disable Current (Sink)		100	150	μA
Logic Disable Power In		0.5	1	W
Input Ripple Rejection (120 Hz)		50		dB
Input Ripple Rejection (800 Hz)		40		dB
Efficiency (FL) [fig. II & III]*	72	78-85		%
3.3 Vdc Output (FL)	70	75		%
2 Vdc Output (FL)	63	69		%

EMI: Units conform to MIL-STD-461D (on the input leads) with companion filter

Input Transient: Units can withstand 24V transients for up to 0.1 second

STABILITY

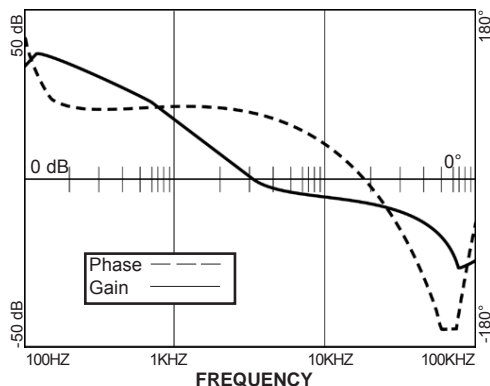

FEATURES

- .38 Inch Profile
- Synchronization
- N + 1 Redundancy
- Remote Turn On (TTL)
- Parallelable Operation
- Output Voltage Trim Pin
- Over Temperature Protection
- Output Overvoltage/Overcurrent Protection
- Built-In Test (Output Power Good)
- 100% Environmental Screening (Military Version)

SELECTION CHART

Nominal Output Voltage	Output Current (Amps)	Model Number (Industrial)	Model Number (Military)
2	10	NL50SI/2-A	NL50SM/2-A
3.3	10	NL50SI/3.3-A	NL50SM/3.3-A
5	10	NL50SI/5-A	NL50SM/5-A
5.2	9.6	NL50SI/5.2-A	NL50SM/5.2-A
12	4.2	NL50SI/12-A	NL50SM/12-A
15	3.3	NL50SI/15-A	NL50SM/15-A

OUTPUT CHARACTERISTICS

	PER CHANNEL			Units
	Min.	Typ.	Max.	
Set Point Accuracy			1 †	% V _{out}
Load Regulation		10	30	mV
Line Regulation		5	25	mV
Ripple P-P (10 MHz) [fig. IV]*		50	150	mV
Trim Range	100		110	% V _{out}
Remote Sense Compensation		0.5		Vdc
Overvoltage Protection (2V, 3.3V)		140		% V _{out}
Overvoltage Protection (5V-15V)		130		% V _{out}
Current Sharing		±10		% I _{out}
Transient Response (V _{out} 1%) Time/Overshoot [fig.V & VI]*				
20-80% Load		300/250		μS/mV
Low Line - High Line		250/200		μS/mV
50-100% Load		250/200		μS/mV
Temperature Drift		0.01	0.05	%/°C
Long Term Drift		0.01	0.02	%/1Khrs
Current Limit	105	125	150	% I _{out}
Short Circuit Current	20		75	% I _{out}
Turn On Time [fig. XI]*		3		mS
Logic Turn On Time [fig. IX]*		3		mS

† 1% or 50mV, whichever is greater

* figures on page 10

All specifications are typical @+25°C with nominal input voltage under full output load conditions, unless otherwise noted. Specifications subject to change without notice.

Martek Power Abbott, Inc. 1111 Knox Street, Torrance, CA 90034 USA
<http://www.martekpowerabbott.com>

TEL (310) 202-8820 FAX (310) 836-4926
 email: sales.mpa@martekpower.com

HIGH DENSITY
DC TO DC CONVERTERS

Industrial & Military Grades

TEMPERATURE CHARACTERISTICS

	Min.	Typ.	Max.	Units
Operating	-55		+100	°C
Storage (Ambient)	-55		+125	°C
Over Temperature Shutdown		+105		°C
Thermal Resistance Case - Ambient		9		°C/W

ENVIRONMENTAL SCREENING - M MODEL

Stabilization Bake:	+125°C for 24 hours similar to Mil-Std-883, M1008.2, Condition B
Temperature Cycling:	10 cycles at -55°C to +125°C (transition period 36 minutes) similar to Mil-Std-883, M1010, Condition B
Burn-in:	160 hours at +85°C min.
Final Testing	

ENVIRONMENTAL SCREENING - I MODEL

Burn-in:	16 hours at +85°C min.
Final Testing	

See "Guide to Operation" for full details.

ISOLATION CHARACTERISTICS

	Min.	Typ.	Units
Isolation:			
Input to Output	250		Vdc
Output to Base	100		Vdc
Input to Base	100		Vdc
Input to Output Capacitance		0.022	µf
Insulation Resistance (@50 Vdc)	50		MOhm

MECHANICAL CHARACTERISTICS

Weight	3.2	oz.
	90	grams
Size	3.0 x 1.5 x 0.38	inch
	76.2 x 38.1 x 9.7	mm
Volume	1.71	inch ³
	28	cm ³
Material	Pin	Brass (Solder Plating)
	Baseplate	Aluminum 5052-H32
	Case	28 Gauge Steel (cold rolled)
Finish		Nickel Plating
Mounting	Standard	4-40 inserts provided in baseplate
	I Option	M2.5 metric inserts (4 places)
	D Option	0.115 DIA thru holes (4 places)

CASE DRAWINGS

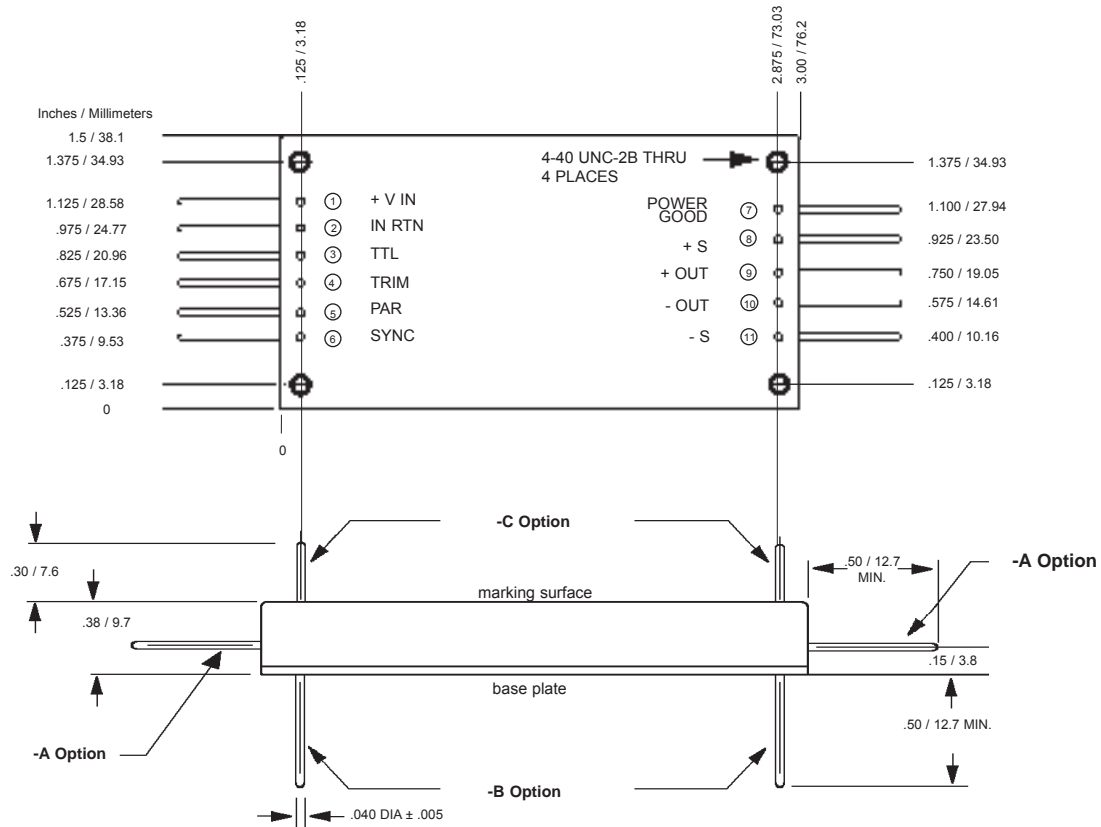

Tolerances: inches - x.xx = ±0.03 mm - x.x = ±0.8
x.xxx = ±0.015 x.xx = ±0.40

All specifications are typical @+25°C with nominal input voltage under full output load conditions, unless otherwise noted. Specifications subject to change without notice.

NL100

100 Watts Output Power

SINGLE AND DUAL OUTPUTS



How to Order:

NL 100 D I / 5 / 15 - A - D

Series	Output Voltages: One number is for single output or two numbers for dual output. Maximum current as stated in selection chart.	Options: A- pins out side of unit B- pins out bottom of unit C- pins out top of unit D- through hole inserts (STD threaded) I - M2.5 inserts
Total Output Power		
Single (S), Dual (D) Output		
Industrial (I) or Military (M)		

Model Numbering Example:

To order a 100 watt, 15 V out (single output), industrial grade power supply with pins out the side, the model number would be: NL100SI/15-A. Military grade would be NL100SM/15-A. To order a 100 watt, dual output, 15 V and 15 V, industrial grade power supply with pins out the top, the model number would be NL100DI/15/15-C. Dual output, 12 V and 15 V, military grade, would be NL100DM/12/15-C. When ordering a dual output unit, the first output voltage in the model number is located on channel 1, and the second output voltage in the model number is located on channel 2 (see case drawing for details).

INPUT CHARACTERISTICS

PER CHANNEL

	Min.	Typ.	Max.	Units
Input Voltage	9	12	18	Vdc
Brown Out (75% of Full Load) [fig. I]*		7		Vdc
No Load Power Dissipation		1	2	Watt
Inrush Charge [fig. VII]*			3.5	mc
Reflective Ripple Current [fig. VIII]*		3		%
Logic Disable Current (Sink)		100	150	µA
Logic Disable Power In		0.5	1	W
Input Ripple Rejection (120 Hz)		50		dB
Input Ripple Rejection (800 Hz)		40		dB
Efficiency (FL) [fig. II & III]*	72	78-85		%
3.3 Vdc Output (FL)	70	75		%
2 Vdc Output (FL)	63	69		%

EMI: Units conform to MIL-STD-461D (on the input leads) with companion filter

Input Transient: Units can withstand 24V transients for up to 0.1 second

STABILITY

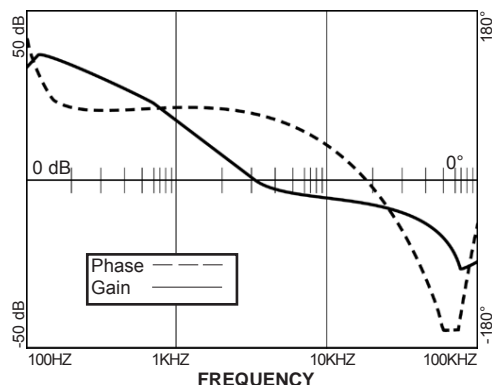

FEATURES

- .38 Inch Profile
- Synchronization
- Remote Turn On (TTL)
- Output Voltage Trim Pin
- Over Temperature Protection
- Output Overvoltage/Overcurrent Protection
- Built-In Test (Output Power Good)
- 100% Environmental Screening (Military Version)
- Outputs Isolated Allowing Any Combination of Output Voltages

SELECTION CHART

Output Voltage and Output Current

Nominal Output Voltage	Single Output Current (Amps)	Dual Per Channel Current (Amps)
2	20	10
3.3	20	10
5	20	10
5.2	19.2	9.6
12	8.3	4.2
15	6.7	3.3

OUTPUT CHARACTERISTICS

PER CHANNEL

	Min.	Typ.	Max.	Units
Set Point Accuracy			1 †	% V _{out}
Load Regulation		10	30	mV
Line Regulation		5	25	mV
Ripple P-P (10 MHz) [fig. IV]*		50	150	mV
Trim Range	100		110	% V _{out}
Remote Sense Compensation		0.5		Vdc
Overvoltage Protection (2V, 3.3V)		140		% V _{out}
Overvoltage Protection (5V-15)		130		% V _{out}
Current Sharing		±10		% I _{out}
Transient Response (Vout 1%) Time/Overshoot [fig. V & VI]*				
20-80% Load		300/250		µS/mV
Low Line - High Line		250/200		µS/mV
50-100% Load		250/200		µS/mV
Temperature Drift		0.01	0.05	%/°C
Long Term Drift		0.01	0.02	%/1KHrs
Current Limit	105	125	150	% I _{out}
Short Circuit Current	20		75	% I _{out}
Turn On Time [fig. XI]*		3		mS
Logic Turn On Time [fig. IX]*		3		mS

† 1% or 50mV, whichever is greater

* figures on page 10 represents per channel

All specifications are typical @+25°C with nominal input voltage under full output load conditions, unless otherwise noted. Specifications subject to change without notice.

HIGH DENSITY DC TO DC CONVERTERS

Industrial & Military Grades

TEMPERATURE CHARACTERISTICS

	Min.	Typ.	Max.	Units
Operating	-55		+100	°C
Storage (Ambient)	-55		+125	°C
Over Temperature Shutdown		+105		°C
Thermal Resistance Case - Ambient		9		°C/W

ENVIRONMENTAL SCREENING - M MODEL

Stabilization Bake:	+125°C for 24 hours similar to Mil-Std-883, M1008.2, Condition B
Temperature Cycling:	10 cycles at -55°C to +125°C (transition period 36 minutes) similar to Mil-Std-883, M1010, Condition B
Burn-in:	160 hours at +85°C min.
Final Testing	

ENVIRONMENTAL SCREENING - I MODEL

Burn-in:	16 hours at +85°C min.
Final Testing	

See "Guide to Operation" for full details.

ISOLATION CHARACTERISTICS

	Min.	Typ.	Units
Isolation:			
Input to Output	250		Vdc
Output to Base	100		Vdc
Input to Base	100		Vdc
Input to Output Capacitance		0.044	µf
Insulation Resistance (@50 Vdc)	50		MOhm

MECHANICAL CHARACTERISTICS

Weight	6.4	oz.
	180	grams
Size	3.0 x 3.0 x 0.38	inch
	76.2 x 76.2 x 9.7	mm
Volume	3.42	inch ³
	56.0	cm ³
Material	Pin	Brass (Solder Plating)
	Baseplate	Aluminum 5052-H32
	Case	28 Gauge Steel (cold rolled)
Finish		Nickel Plating
Mounting	Standard	4-40 inserts provided in baseplate
	I Option	M2.5 metric inserts (4 places)
	D Option	0.115 DIA thru holes (4 places)

CASE DRAWINGS

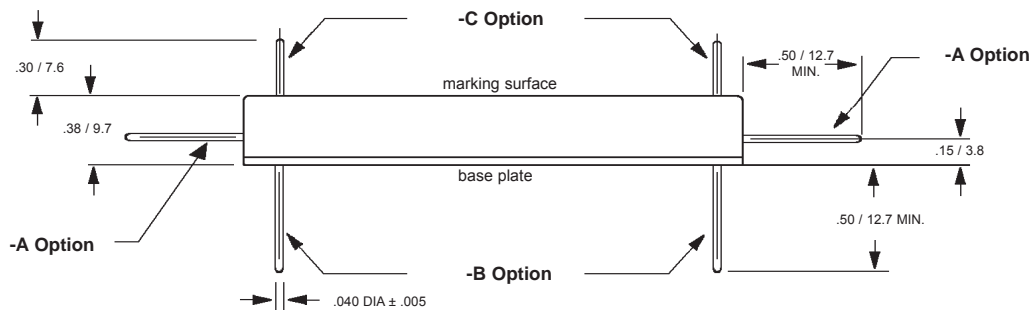
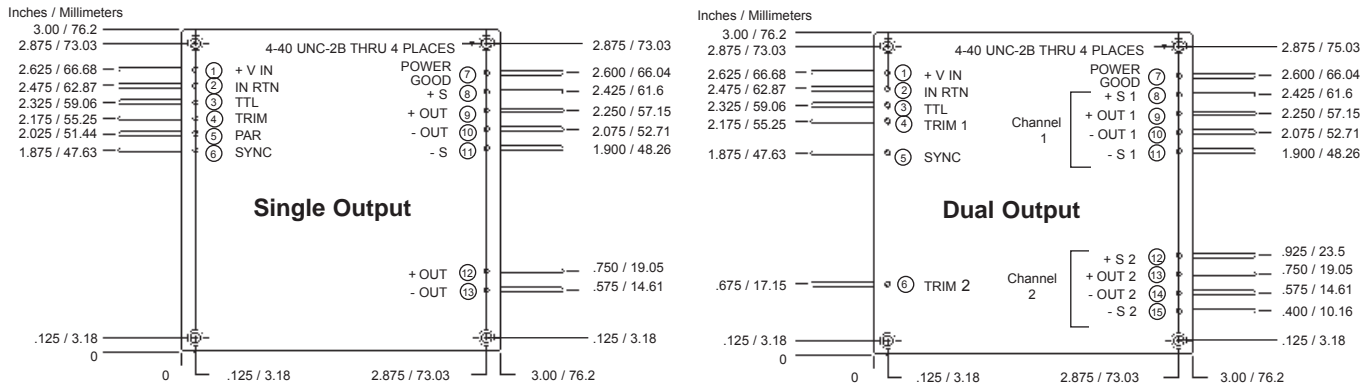

Tolerances: inches - x.xx = ±0.03 mm - x.x = ±0.8
 x.xxx = ±0.015 x.xx = ±0.40

All specifications are typical @+25°C with nominal input voltage under full output load conditions, unless otherwise noted. Specifications subject to change without notice.

Martek Power Abbott, Inc. 1111 Knox Street, Torrance, CA 90034 USA
<http://www.martekpowerabbott.com>

TEL (310) 202-8820 FAX (310) 836-4926
 email: sales.mpa@martekpower.com

NL150

150 Watts Output Power

SINGLE AND TRIPLE OUTPUTS



How to Order:

NL 150 T M / 5/12 /15 - A - D

Series	Output Voltages: One number is for single output or three numbers for triple output. Maximum current as stated in chart.	Options: A- pins out side of unit B- pins out bottom of unit C- pins out top of unit D- through hole inserts (STD threaded) I - M2.5 inserts
Total Output Power		
Single (S), Triple (T) Output		
Industrial (I) or Military (M)		

Model Numbering Example:

To order a 150 watt, 15 V out (single output), industrial grade power supply with pins out the bottom, the model number would be: NL150SI/15-B. Military grade would be NL150SM/15-B. To order a 150 watt, triple output, 15 Vdc, 15 Vdc and 5.2 Vdc, industrial grade power supply with pins out the top, the model number would be NL150TI/15/15/5.2-C. Triple output, 5 V, 12 V and 15 V, military grade, would be NL150TM/5/12/15-C. When ordering a triple output unit, the first output voltage in the model number is located on channel 1, the second output voltage in the model number is located on channel 2, and the third output voltage in the model number is located on channel 3 (see case drawing for details).

INPUT CHARACTERISTICS

PER CHANNEL

	Min.	Typ.	Max.	Units
Input Voltage	9	12	18	Vdc
Brown Out (75% of Full Load) [fig. I]*		7		Vdc
No Load Power Dissipation		1	2	Watt
Inrush Charge [fig. VII]*			3.5	mc
Reflective Ripple Current [fig. VIII]*		3		%
Logic Disable Current (Sink)		100	150	µA
Logic Disable Power In		0.5	1	W
Input Ripple Rejection (120 Hz)		50		dB
Input Ripple Rejection (800 Hz)		40		dB
Efficiency (FL) [fig. II, III]*	72	78-85		%
3.3 Vdc Output (FL)	70	75		%
2 Vdc Output (FL)	63	69		%

EMI: Units conform to MIL-STD-461D (on the input leads) with companion filter

Input Transient: Units can withstand 24V transients for up to 0.1 second

STABILITY

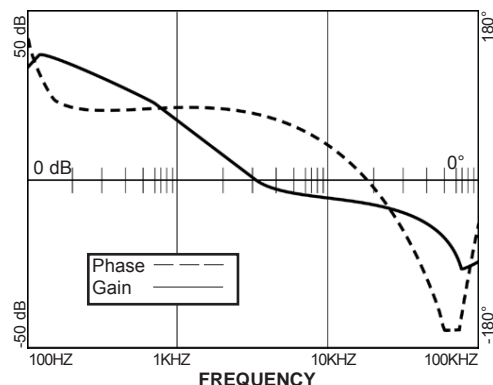

FEATURES

- .38 Inch Profile
- Synchronization
- Remote Turn On (TTL)
- Output Voltage Trim Pin
- Single and Triple Outputs
- Over Temperature Protection
- Built-In Test (Output Power Good)
- N + 1 Redundancy (Single Output)
- Triple Outputs are Isolated Allowing Any Combination of Output Voltages
- 100% Environmental Screening (Military Version)

SELECTION CHART

Output Voltage and Output Current

Nominal Output Voltage	Single Output Current (Amps)	Triple Per Channel Current (Amps)
2	30	10
3.3	30	10
5	30	10
5.2	28.8	9.6
12	12.6	4.2
15	10	3.3

OUTPUT CHARACTERISTICS

PER CHANNEL

	Min.	Typ.	Max.	Units
Set Point Accuracy			1 †	% V _{out}
Load Regulation		10	30	mV
Line Regulation		5	25	mV
Ripple P-P (10 MHz) [fig. IV]*		50	150	mV
Trim Range	100		110	% V _{out}
Remote Sense Compensation		0.5		Vdc
Overvoltage Protection (2V, 3.3V)		140		% V _{out}
Overvoltage Protection (5V-15)		130		% V _{out}
Current Sharing		±10		% I _{out}
Transient Response (V _{out} 1%) Time/Overshoot [fig. V & VI]*				
20-80% Load		300/250		µS/mV
Low Line - High Line		250/200		µS/mV
50-100% Load		250/200		µS/mV
Temperature Drift		0.01	0.05	%/°C
Long Term Drift		0.01	0.02	%/1KHrs
Current Limit	105	125	150	% I _{out}
Short Circuit Current	20		75	% I _{out}
Turn On Time [fig. XI]*		3		mS
Logic Turn On Time [fig. IX]*		3		mS

† 1% or 50mV, whichever is greater

* figures on page 10 represents per channel

All specifications are typical @+25°C with nominal input voltage under full output load conditions, unless otherwise noted. Specifications subject to change without notice.

HIGH DENSITY DC TO DC CONVERTERS

Industrial & Military Grades

TEMPERATURE CHARACTERISTICS

	Min.	Typ.	Max.	Units
Operating	-55		+100	°C
Storage (Ambient)	-55		+125	°C
Over Temperature Shutdown		+105		°C
Thermal Resistance Case - Ambient		9		°C/W

ENVIRONMENTAL SCREENING - M MODEL

Stabilization Bake:	+125°C for 24 hours similar to Mil-Std-883, M1008.2, Condition B
Temperature Cycling:	10 cycles at -55°C to +125°C (transition period 36 minutes) similar to Mil-Std-883, M1010, Condition B
Burn-in:	160 hours at +85°C min.
Final Testing	

ENVIRONMENTAL SCREENING - I MODEL

Burn-in:	16 hours at +85°C min.
Final Testing	

See "Guide to Operation" for full details.

ISOLATION CHARACTERISTICS

	Min.	Typ.	Units
Isolation:			
Input to Output	250		Vdc
Output to Base	100		Vdc
Input to Base	100		Vdc
Input to Output Capacitance		0.066	µf
Insulation Resistance (@50 Vdc)	50		MOhm

MECHANICAL CHARACTERISTICS

Weight	9.6	oz.
	270	grams
Size	3.0 x 4.5 x 0.38	inch
	76.2 x 114.3 x 9.7	mm
Volume	5.13	inch ³
	84	cm ³
Material	Pin	Brass (Solder Plating)
	Baseplate	Aluminum 5052-H32
	Case	28 Gauge Steel (cold rolled)
Finish		Nickel Plating
Mounting	Standard	4-40 inserts provided in baseplate
	I Option	M2.5 metric inserts (6 places)
	D Option	0.115 DIA thru holes (6 places)

CASE DRAWINGS

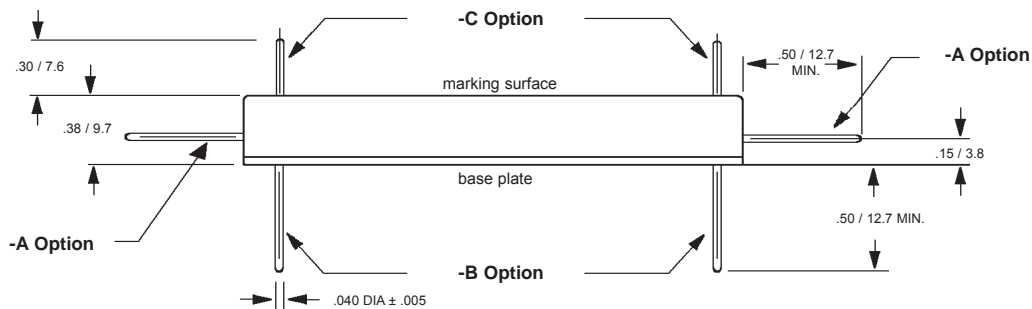
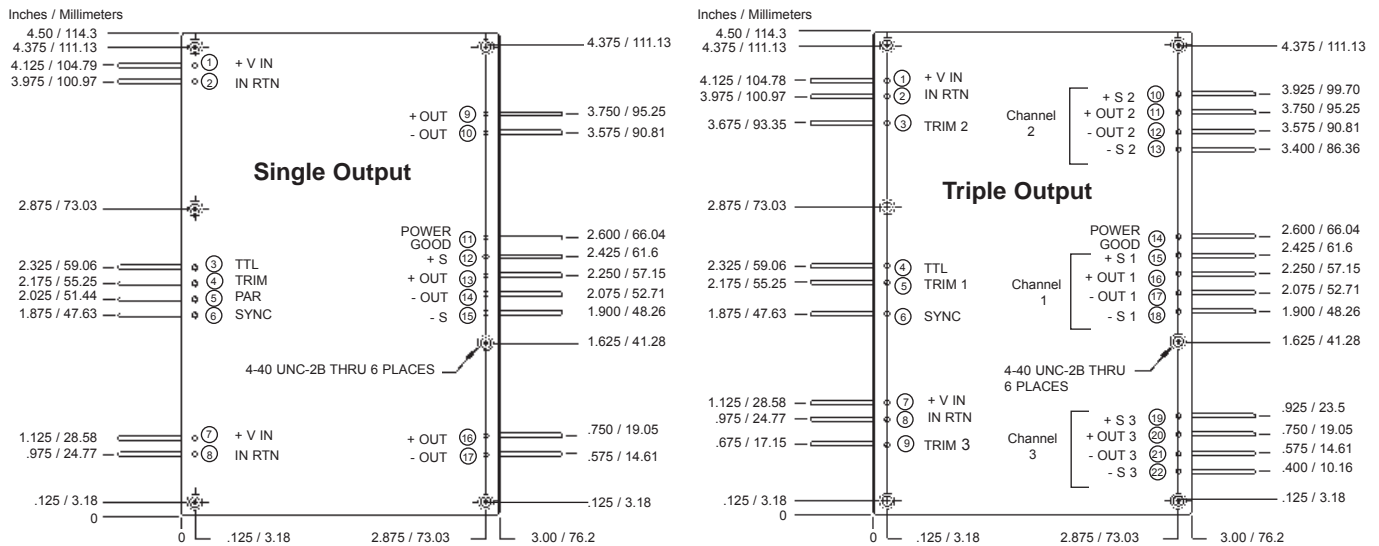

Tolerances: inches - x.xx = ±0.03 mm - x.x = ±0.8
 x.xxx = ±0.015 x.xx = ±0.40

All specifications are typical @+25°C with nominal input voltage under full output load conditions, unless otherwise noted. Specifications subject to change without notice.

NLF50

EMI Filter



How to Order:

NLF 50 - A - D

- Series: NLF 50 - A - D
Total Output Power: 50
- Options:
 A- pins out side of unit
 B- pins out bottom of unit
 C- pins out top of unit
 D- through hole inserts (STD threaded)
 I - M2.5 inserts

EMI COMPARISON GRAPHS

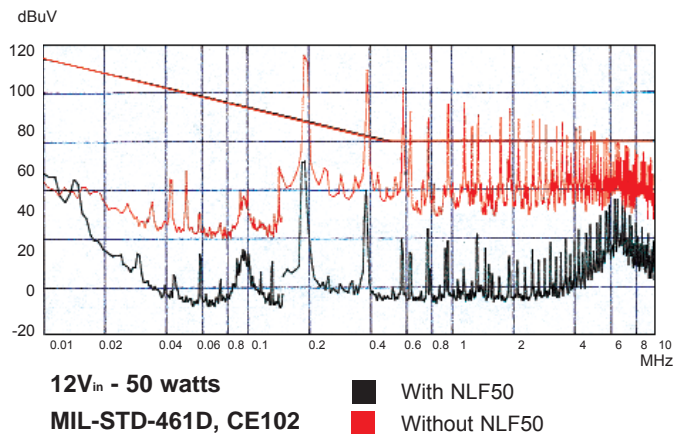
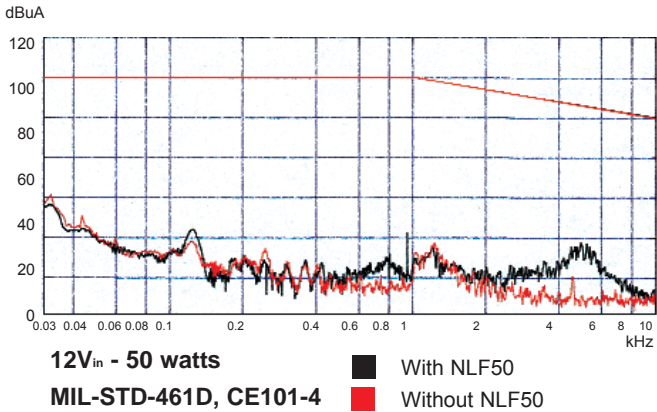

FEATURES

- MIL-STD-461D Compliance CE101 and CE102
- Less than 1.0 volt drop across the NLF50
- Does Not Require External Components
- Meets Environmental Requirements of MIL-STD-810E and MIL-STD-901C
- For Use With NLF50 Series DC/DC Converters

SPECIFICATIONS

Input Voltage (maximum)	24	Vdc
Rated Output Current	8	A
Isolation (Input/Output to Case)	100	Vdc
Operating Temperature	-55 + 100	°C
Storage Temperature	-55 + 125	°C
Insulation Resistance (measured at 50Vdc)	50	M Ohm
Weight	1.9	oz.
	54	grams
Size	1.75 x 1.5 x 0.38	inch
	44.5 x 38.1 x 9.7	mm
Volume	1.00	inch ³
	16.5	cm ³
Material	Pin	Brass (Solder Plating)
	Baseplate	Aluminum 5052-H32
	Case	28 Gauge Steel (cold rolled)
Finish		Nickel Plating
Mounting	Standard	4-40 inserts provided in baseplate
	I Option	M2.5 metric inserts (4 places)
	D Option	0.115 DIA thru holes (4 places)

CASE DRAWING

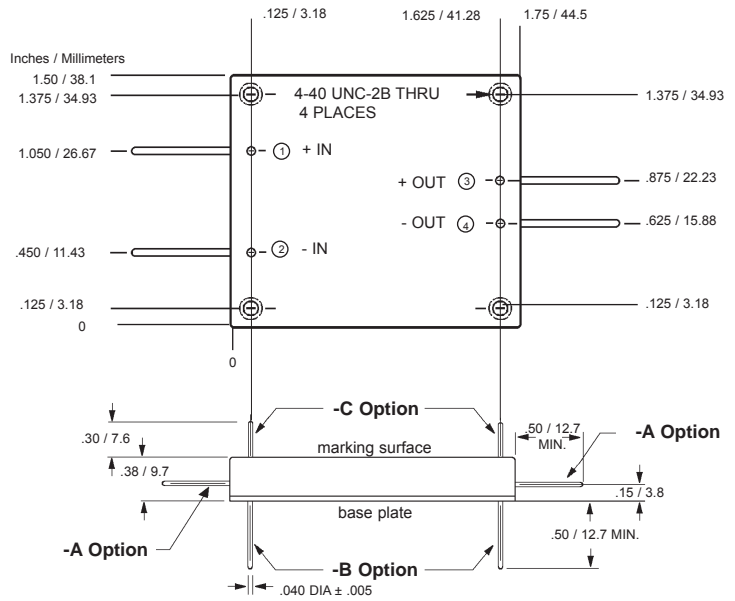

Tolerances:

inches	-	x.xx	= ±0.03
		x.xxx	= ±0.015
mm	-	x.x	= ±0.8
		x.xx	= ±0.40

All specifications are typical @+25°C with nominal input voltage under full output load conditions, unless otherwise noted. Specifications subject to change without notice.

NLF150

EMI Filter



How to Order:

NLF 150 - A - D

Series	Options:
Total Output Power	A- pins out side of unit
	B- pins out bottom of unit
	C- pins out top of unit
	D- through hole inserts (STD threaded)
	I - M2.5 inserts

EMI COMPARISON GRAPHS

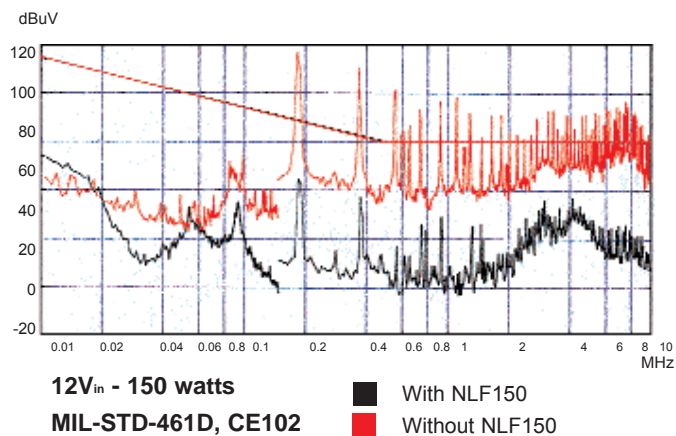
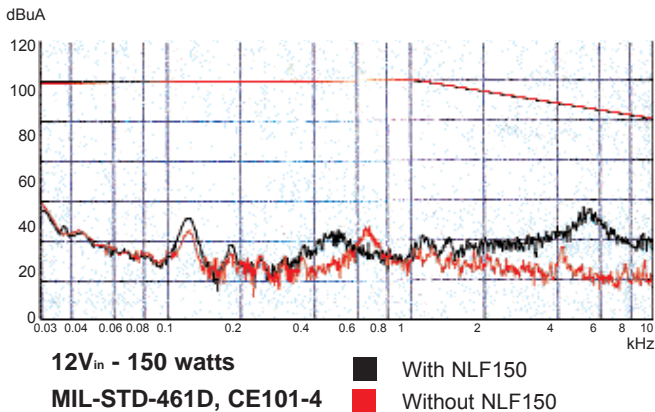

FEATURES

- MIL-STD-461D Compliance CE101 and CE102
- Does Not Require External Components
- Meets Environmental Requirements of MIL-STD-810E and MIL-S-901
- For Use With NL100, NL150 Series DC/DC Converters
- Less than 1 Volt drop across the NLF150

SPECIFICATIONS

Input Voltage (maximum)	24	Vdc
Rated Output Current	24	A
Isolation (Input/Output to Case)	100	Vdc
Operating Temperature	-55 to +100	°C
Storage Temperature	-55 to +125	°C
Insulation Resistance (measured at 50Vdc)	50	M Ohm
Weight	4.0	oz.
	115	grams
Size	3.0 x 2.0 x 0.38	inch
	76.2 x 50.8 x 9.7	mm
Volume	2.28	inch ³
	37.5	cm ³
Material	Pin	Brass (Solder Plating)
	Baseplate	Aluminum 5052-H32
	Case	28 Gauge Steel (cold rolled)
Finish		Nickel Plating
Mounting	Standard	4-40 inserts provided in baseplate
	I Option	M2.5 metric inserts (4 places)
	D Option	0.115 DIA thru holes (4 places)

CASE DRAWINGS

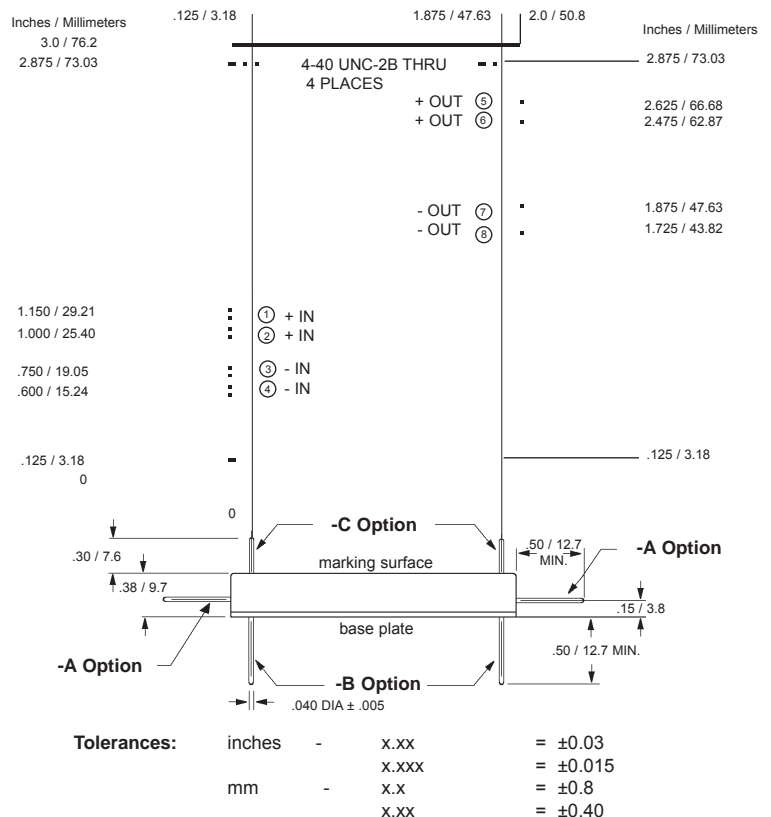

All specifications are typical @+25°C with nominal input voltage under full output load conditions, unless otherwise noted. Specifications subject to change without notice.

PERFORMANCE CHARACTERISTICS

NL50S

NL100

NL150

I. Input Voltage vs. Output Power

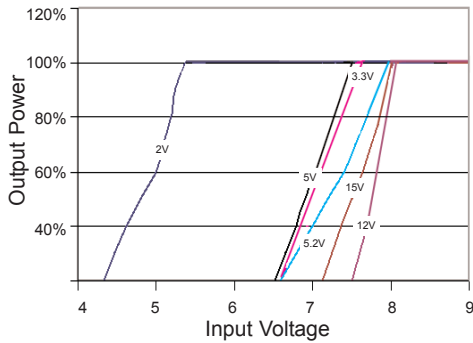

II. Efficiency vs. Output Power

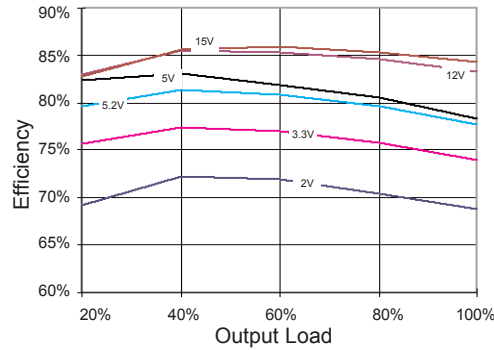

III. Efficiency vs. Input Voltage

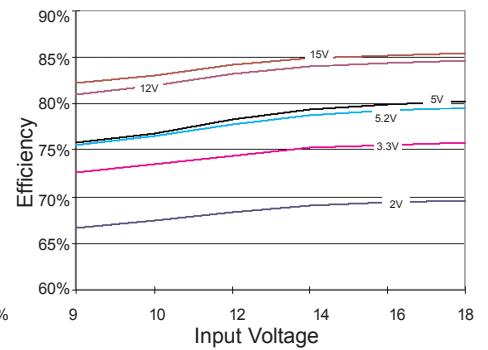

IV. Output Voltage Ripple

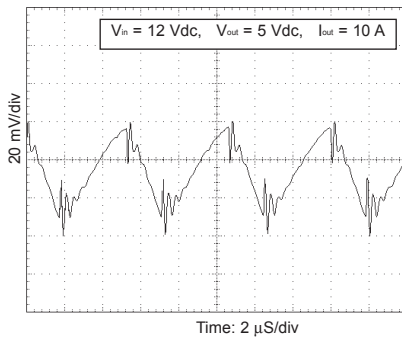

V. Load Transient Response

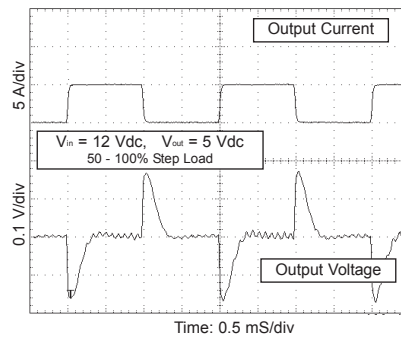

VI. Input Transient Response

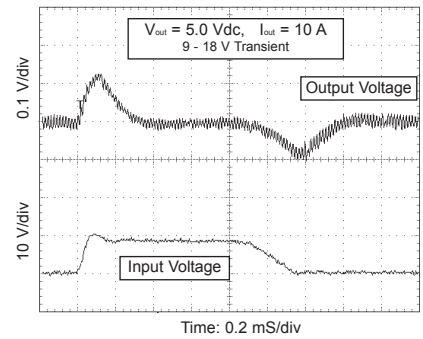

VII. Input Inrush Current

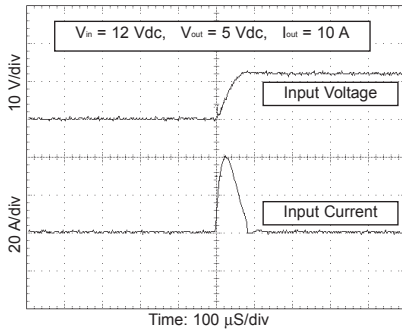

VIII. Input Current Ripple

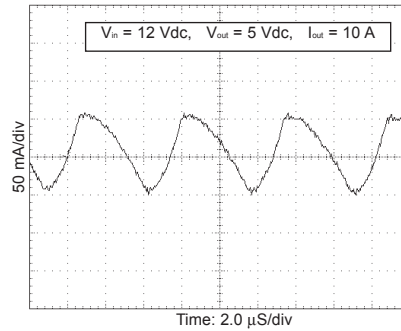

IX. TTL Turn On

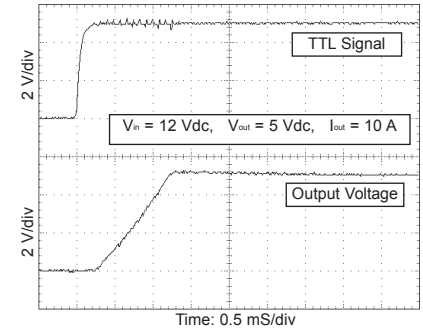

X. TTL Turn-off

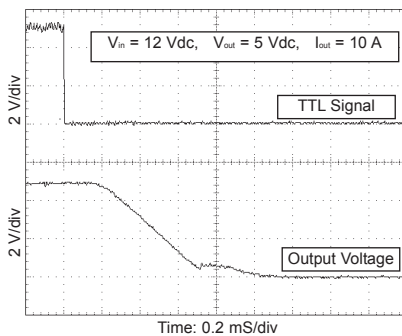

XI. Turn-on

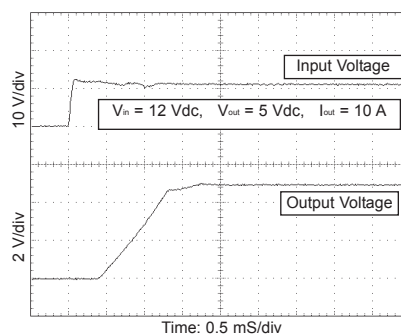

XII. Turn-off / Hold-up Time

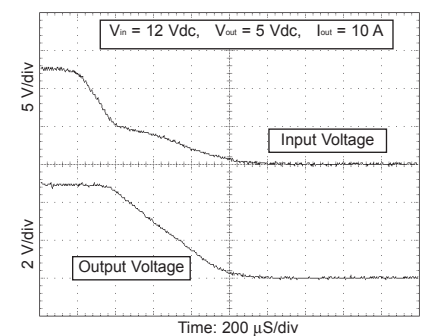

GUIDE TO OPERATION

I. ELECTRICAL DESCRIPTION

The NL Series of DC-DC converters utilize a unique planar power transformer yielding significantly greater power densities than existing designs. Advanced current mode control is utilized enabling fast transient response time. Input to output isolation is accomplished via magnetic feedback. The switching frequency of the NL series is fixed at 200kHz (factory set; greater than 180kHz and less than 200kHz) to minimize noise and allow for simplified EMI filtering (a companion EMI module is available).

II. MECHANICAL DESCRIPTION

General

The NL series converters are encased in a 5 sided steel can with an aluminum baseplate to facilitate heat transfer. Their height dimension of 0.375" allows for mounting in standard 1/2 inch width circuit card racks. The NL series is available in three pin-out configurations; (1) pins out the side, for chassis mounting and maximum height reduction, (2) pins out the top, for PCB mounting with forced air cooling (baseplate exposed to forced air), and (3) pins out the bottom (through the baseplate) for mounting to a metal clad PCB. The pins are non-rigid and may be formed to suit specific mounting configurations. Care should be taken not to excessively bend or over stress the pins to avoid breakage.

The high efficiency of the NL reduces heat dissipation and minimizes heat sinking requirements i.e., typical dissipation of the 50 watt converter operation at full load will be between 10 and 15 watts. Though this reduces heat sinking requirements, **the baseplate temperature must be maintained below +100°C for military versions and +71°C for industrial versions or permanent damage may occur.**

Installation and Mounting

Before mounting the converter be sure that the mounting surface and converter baseplate is clean. Heat sink mounting surfaces must be smooth, flat to within 0.005 and cover the entire baseplate of the module. Based on the calculated power dissipation (see Application Manual on Common Equations for sample calculation) the heatsink should have adequate heat dissipation characteristics. To facilitate heat transfer, apply thermal compound to the base of the module before mounting it to the heat sink. It is extremely important to achieve a good thermal interface between the base of the converter and the heatsink. We highly recommend the use of thermal grease or some other type of conducting material. Failure to achieve a good thermal interface may result in damage to the converter.

There are three types of mounting inserts available on the NL series; smooth through hole, 4-40 or M2.5 metric threaded inserts (to specify which, see "How to Order" section on specification sheet). For the threaded inserts mounting studs should not exceed a penetration of five threads. Each NL series converter has a label on it that will clearly identify pin functions and electrical ratings. Descriptions of these functions can be found in the Guide to Operation and the Application Notes sections. Before electrically wiring the converter we recommend carefully reviewing the application notes section entitled "General Application Notes" and "Wire Gage & Distance to Load".

III. MILITARY SPECIFICATIONS

The NL series is environmentally sealed and are fully qualified to the following military environmental specifications;

Specification	Condition	Method	Procedure	Test Condition
MIL-STD-810E	Vibration	514.4	1	Up to 30gs, each axis for 1 hour
MIL-STD-810E	Humidity	507.3	1	95% humidity, non-condensing for 10 days
MIL-STD-810E	Temp/Altitude	520.1	3	40 hours from -55°C to +71°C
MIL-STD-810E	Acceleration	513.4	3	14gs each axis
MIL-STD-810E	Temperature Shock	503.3		-55°C to +100°C (non-operating, one hour each cycle)
MIL-S-901C	High Impact Shock			5 foot hammer drop
	Input Transient			Transients up to 24 V for 0.1 second

*Certified test reports are available upon request.

The NL series have been tested and found to meet the requirements of Mil-Std-461D for conducted emissions/interference on the input power leads (CE101 and CE102) when used with the appropriate NLF passive EMI filter. In addition, the series have been fully characterized to Mil-Std-461D for radiated interference (RE101, RE102), conducted susceptibility (CS101, CS114, CS115 and CS116) and radiated susceptibility (RS101, RS103). Full test reports are available upon request that detail our level of compliance for each of these conditions.

IV. PRODUCT FEATURES

Output Voltage Sensing (All models)

Output voltage sensing is provided for either local (at the unit) or remote (at the load) sensing. The sense feature can automatically compensate for up to a 0.5V drop in the leads to the load. **The sense pins must be connected (either local or remote) for operation.** If remote sensing is not desired it is required to tie the sense pins locally, i.e., -sense to -output and +sense to +output. See application notes for more details.

Power Good/Built-in-test (All models)

A power good signal (pin) is provided to allow for the monitoring of the output voltage. The power good is set at +5V (referenced to the input return). If the output voltage of the converter drops below 90% of its normal set going (i.e., out of regulation), the power good pin is actively pulled low through a voltage comparator. See application notes for more details.

TTL (Remote on/off) (All Models)

The TTL feature is used to command the NL series on and off and is referenced to the input return. When the TTL pin is left unconnected or, if a voltage between 2.4V and 5.0V is applied to the pin, the converter will remain on. When the TTL pin is pulled down below 0.8V the unit will turn off. See application notes for more details.

Parallel Operation (NL50, 100 and 150 Single Outputs)

A parallel circuit is provided to allow for parallel operation to achieve higher output power or N+1 redundancy. Parallel operation is accomplished by connecting all the parallel pins together (single pin wiring), all synchronization pins together and connecting all input power leads (+ and - leads) together. Units will parallel between $\pm 10\%$ of total output power current.

Over Temperature Protection (All Models)

An integral electronic over temperature shut down circuit is provided to protect the NL series from accidental over heating. If the temperature (measured at the baseplate) of the converter exceeds 5% above the rated high operating temperature, the unit will automatically shut down. Once the temperature (measured at the baseplate) is reduced to 85%, of the rated high operating temperature, power will be automatically restored.

Output Voltage Trim (All Models)

An output voltage trim pin is provided for the adjustment of the output voltage. Using this feature the output voltage can be trimmed up to 110% (trim is only available to increase the output voltage) of nominal. To increase the output voltage of the NL series, simply attach a resistor between the trim pin and the input return of the unit. See application notes for more details.

Switching Frequency Synchronization (All models)

The NL series switching frequency is factory set greater than 180kHz but less than 200kHz. The synchronization clock will be at twice the switching frequency. If desired, several NL units may be synchronized to the same switching frequency by wiring all of the sync pins together and wiring all input returns of the units together. The unit which is switching at the fastest rate will automatically become the "master" and will adjust the remaining units to switch at the same (higher) frequency. Also, the frequency of the synchronized units may be increased by injecting a higher frequency pulsed waveform into the sync pin. See application notes for more details.

Overload/Short Circuit Protection (All Models)

The output of the NL Series is protected from an accidental overload or short circuit condition of any duration. When the output load exceeds the full load capability of the supply (between 105% to 150% of the maximum rated output current) the converter switches into a "Burrp-Mode" (this is where the converter is sensing the overload and is continuously turning on and off in a controlled fashion). When the overload/short circuit is removed the con-

verter automatically returns to its normal mode of operation.

Over Voltage Protection (All Models)

The NL series provides an internal “Latching” output overvoltage protection circuit. Should an output overvoltage condition occur, the converter will shut off. **Input must be recycled to restore output.**

V. RELIABILITY

Reliability Calculation

In order to achieve superior reliability, the NL series converters adhere to the stringent component derating guidelines of NAVMAT P4855-1. The Mean Time Between Failure (MTBF) per Mil-HBDBK-217F Notice 2 for the NL Series under the operating conditions of 50°C baseplate, maximum rated output power for a ground benign environment is calculated in the following table. Test reports for all models are available upon request.

MODEL	MTBF HOURS
NL50SM (Military)	1,770,000
NL50SI (Industrial)	567,000

Standard Military Grade Module Screening

Each military grade NL module under goes environmental screening based upon the parameters outlined in Mil-Std-883 and NAVMAT P4855-1. The screening and process steps consist of the following;

- 1 STABILIZATION BAKE; +125°C FOR 24 HOURS PER MIL-STD-883, M1008.2 CONDITION B
- 2 VOLTAGE ISOLATION AND PARAMETRIC TESTING AT 25°C
- 3 MODULE ENCAPSULATION
- 4 TEMPERATURE CYCLING (NON-OPERATIONAL); 10 CYCLES MINIMUM, AT -55°C TO +125°C, 36 MINUTE TRANSITION WITH A 1 HOUR DWELL AT EACH TEMPERATURE EXTREME. PROCEDURE REFERENCE MIL-STD-883, M1010, CONDITION B AND NAVMAT P4855-1.
- 5 VOLTAGE ISOLATION AND PARAMETRIC TESTING AT 25°C
- 6 LONG TERM OPERATIONAL BURN IN; 160 HOURS OF POWERED OPERATION UNDER LOAD. MODULES ARE CONTINUOUSLY CYCLED FROM +85°C TO THERMAL SHUT DOWN POINT (+105°C) DURING THE 160 HOURS.
- 7 VOLTAGE ISOLATION AND PARAMETRIC TESTING AT 25°C
- 8 VISUAL INSPECTION

Additional testing is available including parametric testing at temperature or extended burn in time. Consult factory for more information. Additional testing or customer specific testing will require additional charges.

Accelerated Life Testing

An accelerated life test was performed on representative sample units of the NL series to determine the long-term effects on performance. Units were subjected to 450 thermal cycles (non-operational) of -55°C to +125°C, and 50 thermal cycles (operational) between -55°C and 70°C. At every 50th cycle modules were given full parametric testing. At the conclusion of the 500th cycle modules were found to operate within published specifications.

Additional qualifications tests include: monitored, 3 axis, random vibration with power applied at full output load; 25 thermal shock cycles between -55 and 125°C (non operational) and 2200 hour (3 month) high temperature burn-in at full output load.

APPLICATION NOTES

General Application Notes.....	15
Wire Gage & Distance to Load.....	15
Ripple & Noise.....	16
Remote Sense.....	17
Remote On/Off.....	17
Output Trim.....	18
Series Operation.....	19
Parallel Operation.....	19
Synchronization.....	19
Power Good Signal.....	20
Electro Magnetic Filter (EMI) NLF50/150.....	20
Trim Values.....	21
Applications Manual.....	22
Block Diagram.....	23
Frequently Asked Questions.....	24

General Application Notes

The NL Series of DC-DC converters utilize a unique planar power transformer yielding significantly greater power densities than existing designs. Advanced current mode control is utilized enabling fast transient response time. Input to output isolation is accomplished via magnetic feedback. The switching frequency of the NL series is fixed at 200kHz (factory set; greater than 180kHz but less than 200kHz) to minimize noise and allow for simplified EMI filtering (a companion EMI module is available). Sufficient capacitance on the input and output, internal to the unit, allows for simple use and operation with no external components in most applications.

The NL units are supplied in a five sided metal case to minimize radiated noise. The height dimension of 0.375" allows for mounting in standard 1/2 inch width circuit card racks. The NL is available in three pin-out configurations; 1) pins out the side for chassis mounting and maximum height reduction, 2) pins out the top for PCB mounting with forced air cooling (baseplate exposed to forced air), and 3) pins out the bottom (through the baseplate) for conduction cooling via a metal clad board. The high efficiency of the NL reduces head dissipation and minimizes heat sinking requirements i.e., maximum dissipation of the 50 watt converter will be between 10 and 15 watts. A number of protection features, as well as electrical and thermal derating of internal components allows for high reliability throughout the entire operating ranges. There are two operating ranges available, -40 °C to +71°C (for industrial applications) and -55 °C to +100 °C (for military applications). Qualification test reports to Mil-Std-810E and Mil-Std-901C are available on request.

The most basic use of the power converter is shown in figure 1. An input fuse is always recommended to protect both the source and the power supply in the event of failures. Bus fuse type MDX or equivalent slow-blow is recommended with a current rating approximately 200% of the full load input current to the converter. Having a slow-blow type fuse will allow for the converter's inrush charge at turn-on.

The sense pins of the converter must be connected to their corresponding output bus. Inherently, power converters will have some internal energy loss, which is dissipated in the form of heat through an aluminum mounting surface. This surface must be cooled to maintain a temperature below the maximum operating temperature.

Basic Converter Hook-up

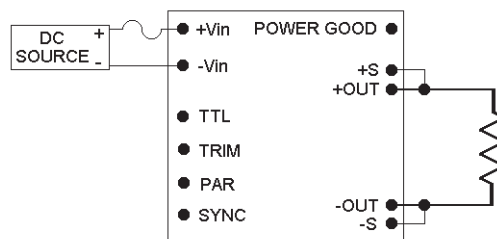

Figure 1

Wire Gage & Distance to Load

If the resistance of the wire, printed circuit board runs or connectors used to connect a converter to system components is too high, excessive voltage drop will result between the converter and system components, degrading overall system performance.

For example, if the DC/DC converter in Figure 1a is a 50W unit (5 VDC @ 10 Amps) with output load regulation specified at 0.2%; the connection as shown will degrade load regulation by a factor of 10. In this example, the 4 feet of #14 AWG wire used to connect the converter output to the load, has a total line resistance of 10 mW (ignoring any contact resistance). For a 50W, 5VDC output converter, the drop across the lead resistance will be 100 mV (10 A X 0.010W) or 2% of the output. Thus, the converter was selected for 0.2% regulation, but the power system layout achieves only 2.2%.

This can be corrected by decreasing the distance between the converter output and load. If that is not possible, using larger diameter wire (see table 1), or PCB runs that have a larger cross sectional area and shorter length will also reduce conductor resistance. The use of

Basic Hook-up

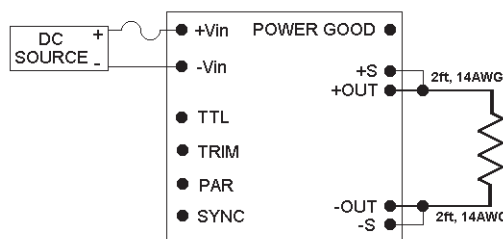

Figure 1a

the converter's remote sense capability will also work (see remote sense for more information on this option).

#AWG	Current Resistance mΩ/Foot	#AWG	Current Resistance mΩ/Foot
9	0.792	21	12.77
10	0.998	22	16.20
11	1.261	23	20.30
12	1.558	24	25.67
13	2.001	25	32.37
14	2.524	26	41.02
15	3.181	27	51.44
16	4.020	28	65.31
17	5.054	29	81.21
18	6.386	30	103.7
19	8.046	31	130.9
20	10.13	32	162.0

Table 1

Note: High IR drops between the converter and load may cause converter parameters such as output voltage accuracy, trim range, etc. to appear to be out of specification. High IR drops on input lines may cause start up problems (voltage at the input pins below the input range of the converter).

Obviously, any connections made to the power distribution bus may present a problem. Poor connections (such as microcracking around solder joints) can cause serious problems such as arcing. Contact resistance must be minimized. Proper workmanship standards must be followed to insure reliable solder joints for board mount converters.

Terminal strips, spade lugs and edge connectors must be free of any corrosion, dust or dirt. If parallel lines or connections are available for routing converter output currents, they should be utilized.

Ripple & Noise

Output ripple and noise (sometimes referred to as PARD or "Periodic and Random Deviations") can be defined as unwanted variations in the output voltage of a power supply. In switching power supplies this output noise is seen as a series of pulses with a high frequency content and is therefore measured as a peak value (i.e., specified as "peak-to-peak").

Abbott power supplies are specified and tested in our factory with a 25 MHz or 10 Mhz bandwidth oscilloscope. Measurements taken by a scope set at higher frequencies (i.e. 300 MHz) may produce significantly different results due to noise coupling on to the probe from sources other than the power supply.

Noise that is common to all output leads of a power converter with respect to the chassis is referred to as common mode noise. Noise that is apparent on one output lead with respect to corresponding output lead is referred to differential mode noise. Common mode noise is produced in switching action. Abbott typically minimizes the level of output common mode noise by incorporating line to chassis ground capacitors (on input and output leads) into the power converters. In most cases this is sufficient to minimize the level of common mode noise, however if further attenuation is required additional line to chassis ground capacitance may be added by the customer at the system level. Abbott noise specifications (output ripple specifications) all reference the level of differential mode noise at a given bandwidth, not the level of common mode noise. The measurement of differential mode noise is detailed in the following paragraphs.

Measurement Techniques

The length of all measurements leads (especially the ground lead) should be minimized and the sense pins should be tied to their respective outputs (+Sense to +V out). We recommend measurement as close to the supply as possible. This can be accomplished by connecting a short bus wire (generally 0.5 inches or less, making a loop at the end to place in the probe) to the negative and positive outputs on the back side of the connector mate, then place the tip of the probe on the +output and ground ring (or ground band) on the -output for a true ripple measurement. This is displayed in figure 1b;

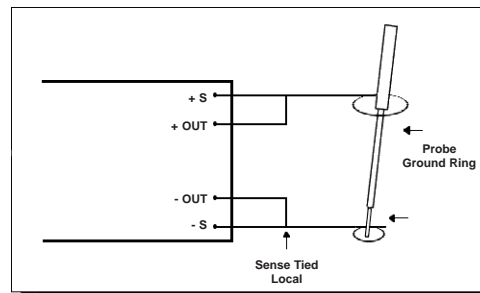

Figure 1b

Utilizing the probe ground ring (as opposed to a ground wire) will minimize the chance of noise coupling from sources other than the power supply. If this is not practical or possible then attach a 6 to 8 inch twisted pair wire to the outputs of the power supply and place a 10-20 uF tantalum capacitor (low ESR type, with an appropriate voltage rating) across the load. This test method is shown on figure 1c.

Remote Sense

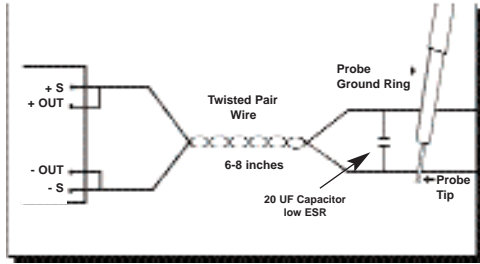

Figure 1c

This test method will enable a remote measurement and eliminate any noise that may couple on to the extended leads coming off the converter.

Ripple Reduction Techniques

In applications where the output ripple of the converter is higher than desired various techniques can be employed to reduce output ripple and noise (PARD). One method is to add additional capacitance in parallel with the output leads of the converter (low ESR type tantalums or ceramics are recommended). This should substantially reduce PARD, but be aware that excessive additional output capacitance can cause converter oscillations (see table 2 for the maximum allowable capacitance that may be added to the output leads and for typical output ripple values with this capacitance added).

Output Voltage	Maximum Capacitance per 50W channel	Typical Vp-p@10MHZ (full load, nominal input voltage)
2V	1100uF	15mV
3.3V	1100uF	20mV
5V	1100uF	20mV
5.2V	1100uF	20mV
12V	110uF	20mV
15V	75uF	20mV

Table 2

Another way to reduce PARD is to use Martek Power Abbott's output ripple attenuator module, SMRA (see table 3 for typical output ripple values while using the SMRA with an NL series 50 watt channel. Full specifications for the SMRA module can be found in the SM series data book).

Output Voltage	Typical Vp-p@10MHZ (full load, nominal input voltage)
2V	15mV
3.3V	20mV
5V	15mV
5.2V	15mV
12V	15mV
15V	15mV

Table 3

Remote sense pins, +S and -S have been provided on the NL Series converters for applications where precise load regulation is required at a distance from where the converter is physically located. If remote sensing is NOT required, these pins **MUST be tied** to their respective output pins (+S to +OUT and -S to -OUT). If one or more of these sense pins are not connected to their respective output pins, the output(s) of the unit will not regulate to within specification and may cause a high output voltage condition.

Remote Sense - Single Output

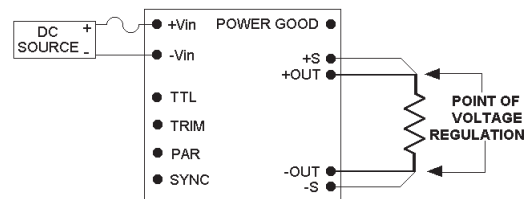

Figure 2

•DO NOT connect sense pins to any pin other than their respective output pins or permanent damage will occur.

•DO NOT connect sense pins to any load other than the same load the output pins are connected to or permanent damage may occur.

The internal remote sense circuit is designed to compensate for a maximum of 0.5V difference (0.25V in each output lead) in voltage between the load and the power converter. Longer output leads or traces are required to be of sufficient gauge or width to maintain the voltage drop across them of 0.5V maximum at rated load current.

Remote On/Off

Remote turn ON/ turn OFF feature (TTL) is an additional feature of the NL Series. This feature is especially useful in portable/mobile applications where battery power conservation is critical or in applications involving high power pulsed loads where inrush currents are high.

The NL Series employs a typical TTL open collector with positive logic control pin. The voltage level at the TTL pin is referenced with respect to the converter -VIN input. When the TTL circuit is pulled to less than 0.8 V ("logic 0") with respect to the -VIN pin, via either an open collector (see figure 3), or totem-pole driver, or a mechanical switch, with a 100µA capability, the converter shuts down. An optocoupler can also be used if the TTL signal needs to be referenced from the output side. If the TTL pin is left floating or is pulled above 2.4V up to 5.0V ('logic 1') the unit will remain on. Many more devices can be used to activate the TTL pin shut-down function, consult the factory for your specific requirements. When employing multiple NL modules which are to be turned on and off at the same time, tie the TTL pins of every module together.

Remote Turn On/Off

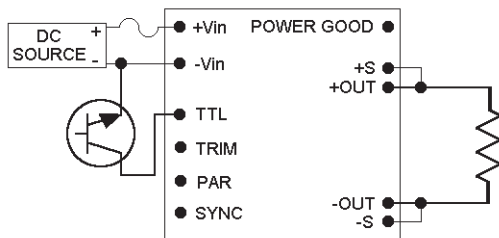

Figure 3

Output Trim

The output voltage is increased by simply connecting a resistor between the trim pin and the input voltage pin (see figure 4).

Basic Trim

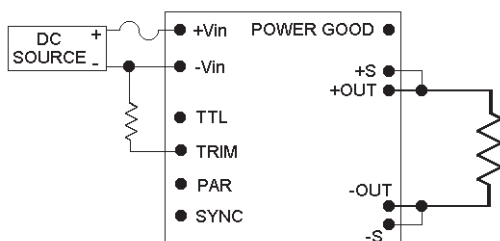

Figure 4

The value of the resistor required is determined by using the equation below.

$$R_{(NL50S)}^* = \frac{R_3(R_2 + R_4 - R_2 V_{OUT}) + R_4 R_2}{R_2(V_{OUT} - 1) - R_4}$$

$$R_{(NL100S)} = \frac{R^*}{2} \quad R_{(NL150S)} = \frac{R^*}{3}$$

The values of R2, R3 and R4 are output voltage dependent per the following table:

V _{OUT}	R ₂	R ₃	R ₄
2V	20K	20K	18.70K
3.3V	8.25K	20K	18.70K
5V	10K	20K	39.0K
5.2V	10K	20K	39.0K
12V	3.65K	8.25K	39.0K
15V	2.74K	8.25K	39.0K

Note: The equation for R is valid for the NL50S, 100D and 150T. For the NL100S and 150S, use the R(NL100S) and R(NL150S) equations accordingly.

Resistor values for trim ranges have been calculated for your reference on page 24.

Example 1:

We have a NL50S with a 12 volt output but need trimming up to 13 Vdc. The equation would be as follows,

$$R = \frac{8.25K(3.65K + 39K - 3.65K(13)) + 39K(3.65K)}{3.65K(13 - 1) - 39K}$$

$$R = 21.41K\Omega$$

By using a 21.41KΩ resistor for the trim resistor R, the output voltage will be 13 Vdc.

Figure 4a shows a scheme for a continuously variable output from 100% to 110% of nominal output voltage (voltages higher than 110% may activate the overvoltage protection circuit).

Variable Trimming

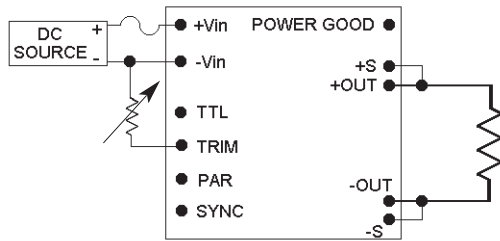

Figure 4a

Series Operation

The NL family of power converters may be arranged in a series operating mode to supply higher output voltages when required (see figure 5). In this configuration D1 and D2 are added to protect against the application of a negative voltage across the outputs of the power converters during power up and power down. The two (or more) units need not have the same output voltage, but the output current supplied in this configuration will be limited to the lowest maximum output current of the modules used.

Series Operation

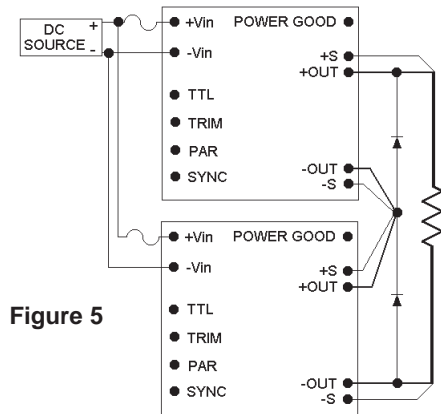

Figure 5

Parallel Operation

The NL Series converter has the capability of being paralleled to drive loads of higher power. The PAR pin is supplied on the unit for this function. If parallel operation of two or more units is required, the following precautions must be followed. (NOTE: It is not recommended to parallel more than five 50 watt units or two 100 watt units. The 150 watt units may be paralleled to a maximum power level of 250 watts.)

- Corresponding input and output leads or traces on each unit should be as equal in length and size as practical. The more equivalent the leads are the closer the current sharing.
- The leads connecting the PAR, SYNC and -IN pins may need to be shielded to avoid high frequency noise interference in very high power applications.
- The PAR, SYNC and -IN pins of all units should be tied together.

OR-ing diodes may be included in the positive output leads for true N+1 redundant systems, but are not necessary. Local sensing should be used whenever possible to minimize noise on +S and -S pins in parallel applications. In some applications, especially in those where it is difficult to keep output and input leads of equal size and length, a series resistance may be inserted in the +S lead. This will give the converter the ability to compensate for lead imbalance. Note: this will also result in a slightly higher output voltage.

Parallel Operation

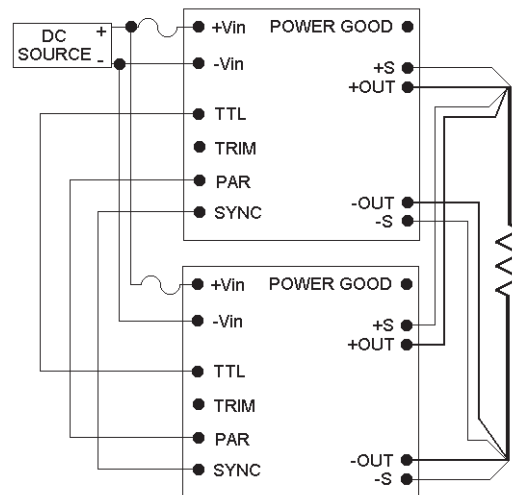

Figure 6

Synchronization

Synchronization of multiple units to each other or to a central clock frequency is essential in noise sensitive systems. The NL Series units are capable of being synchronized to each other by tying the SYNC and -IN pins together. This will synchronize all of the units together (see figure 7).

Synchronization of NL Units

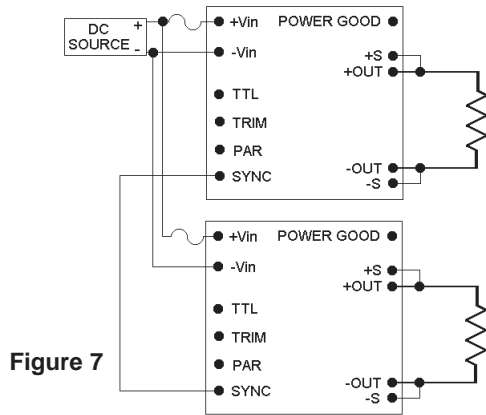

Figure 7

The NL Series converter can be tied to the central clock (see figure 7a) by inputting a square wave clock signal (standard TTL levels of '0V' and '5V' are recommended) which has a frequency of 400 kHz or greater (a period of 2.5 μ S or lower) and a duty cycle of no less than 10% (a pulse width of greater than 0.25 μ S). The NL Series converter's internal synchronization circuit is triggered by the rising edge of this clock waveform. **The frequency can be increased by the external clock between the frequency range of 400-420 KHz.** The input resistance of the SYNC pin for each NL50S is 110 ohm. Higher frequencies make the unit less noise tolerant and care should be taken in how the SYNC pin line is connected between units and/or system clock. In some cases shielding the SYNC pin line will help eliminate the noise. Do not add any capacitance from the SYNC pin line to ground.

Synchronization to External Clock

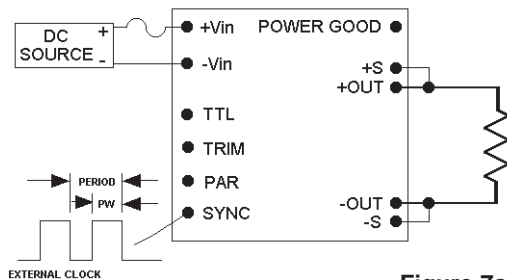

Figure 7a

Power Good Signal

The power good signal is provided to allow for the monitoring of the output voltage. The power good is set to +5V (referenced to the input return) whenever the output of the unit is above 90% of its nominal value.

Power Good

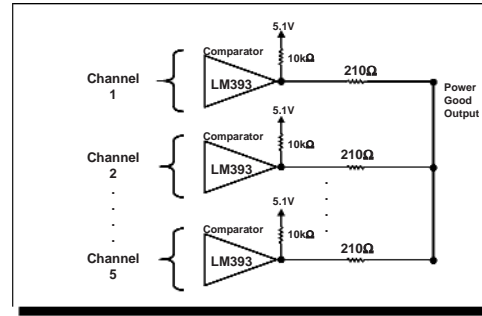

Figure 8

If the output voltage falls below this point the power good pin is actively pulled low. Also, if the output over-voltage circuit triggers due to an overvoltage condition the power good pin is actively pulled low.

See figure 8 for a schematic of the power good circuitry internal to the unit. This figure shows a comparator with a series resistance of 210 Ω to the external power good pin. When multiple channels are utilized the power good circuitry is connected as shown (i.e., the NL150T has three channels and therefore has three power good circuits connected together internal to the unit).

Electro Magnetic Filter (EMI) NLF50 & NLF150

For applications where electromagnetic interference is a concern, the NLF (50 and 150 watt capable), a passive input line filter, may be installed at the input of the NL series converter (see figure 9). With the NLF Mil-Std-461D, CE101-4 and CE102 are within compliance on the input leads. Test reports characterizing both filters for conducted and radiated emission and susceptibility are available. Filters guarantee conducted emissions (on the input leads) only. All test reports are certified by an independent testing lab.

NLF Connection

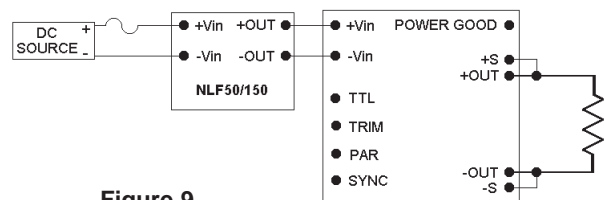

Figure 9

TRIM VALUES

2 V UNIT

	1.00%	2.00%	3.00%	4.00%	5.00%	6.00%	7.00%	8.00%	9.00%	10.00%
R2	20000	41980	41980	41980	41980	41980	41980	41980	41980	41980
R3	20000	20000	20000	20000	20000	20000	20000	20000	20000	20000
R4	20000	20000	20000	20000	20000	20000	20000	20000	20000	20000
VOUT	2.02	2.04	2.06	2.08	2.1	2.12	2.14	2.16	2.18	2.2
R TRIM (50S)	980000	15487	14271	13135	12073	11076	10139	9258	8426	7640
R TRIM (100S)	490000	7744	7136	6568	6036	5538	5070	4629	4213	3820
R TRIM (150S)	326667	5162	4757	4378	4024	3692	3380	3086	2809	2547

3 . 3 V UNIT

	1.00%	2.00%	3.00%	4.00%	5.00%	6.00%	7.00%	8.00%	9.00%	10.00%
R2	8250	8250	8250	8250	8250	8250	8250	8250	8250	8250
R3	20000	20000	20000	20000	20000	20000	20000	20000	20000	20000
R4	18975	18975	18975	18975	18975	18975	18975	18975	18975	18975
VOUT	3.33	3.37	3.4	3.43	3.47	3.5	3.53	3.56	3.6	3.63
R TRIM (50S)	612500	251071	169750	125962	91618	74875	62500	52981	43250	37500
R TRIM (100S)	306250	125536	84875	62981	45809	37438	31250	26490	21625	18750
R TRIM (150S)	204167	83690	56583	41987	30539	24958	20833	17660	14417	12500

5 V UNIT

	1.00%	2.00%	3.00%	4.00%	5.00%	6.00%	7.00%	8.00%	9.00%	10.00%
R2	10000	10000	10000	10000	10000	10000	10000	10000	10000	10000
R3	20000	20000	20000	20000	20000	20000	20000	20000	20000	20000
R4	40000	40000	40000	40000	40000	40000	40000	40000	40000	40000
VOUT	5.05	5.1	5.15	5.2	5.25	5.3	5.35	5.4	5.45	5.5
R TRIM (50S)	780000	380000	246667	180000	140000	113333	94286	80000	68889	60000
R TRIM (100S)	390000	190000	123333	90000	70000	56667	47143	40000	34444	30000
R TRIM (150S)	260000	126667	82222	60000	46667	37778	31429	26667	22963	20000

5 . 2 V UNIT

	1.00%	2.00%	3.00%	4.00%	5.00%	6.00%	7.00%	8.00%	9.00%	10.00%
R2	10000	10000	10000	10000	10000	10000	10000	10000	10000	10000
R3	20000	20000	20000	20000	20000	20000	20000	20000	20000	20000
R4	40500	40500	40500	40500	40500	40500	40500	40500	40500	40500
VOUT	5.25	5.3	5.36	5.41	5.46	5.51	5.56	5.62	5.67	5.72
R TRIM (50S)	182500	142000	110645	92500	78780	68043	59412	51053	45323	40448
R TRIM (100S)	91250	71000	55323	46250	39390	34022	29706	25526	22661	20224
R TRIM (150S)	60833	47333	36882	30833	26260	22681	19804	17018	15108	13483

1 2 V UNIT

	1.00%	2.00%	3.00%	4.00%	5.00%	6.00%	7.00%	8.00%	9.00%	10.00%
R2	3650	3650	3650	3650	3650	3650	3650	3650	3650	3650
R3	8250	8250	8250	8250	8250	8250	8250	8250	8250	8250
R4	40150	40150	40150	40150	40150	40150	40150	40150	40150	40150
VOUT	12.12	12.24	12.36	12.48	12.6	12.72	12.84	12.96	13.08	13.2
R TRIM (50S)	326333	159042	103278	75396	58667	47514	39548	33573	28926	25208
R TRIM (100S)	163167	79521	51639	37698	29333	23757	19774	16786	14463	12604
R TRIM (150S)	108778	53014	34426	25132	19556	15838	13183	11191	9642	8403

1 5 V UNIT

	1.00%	2.00%	3.00%	4.00%	5.00%	6.00%	7.00%	8.00%	9.00%	10.00%
R2	2740	2740	2740	2740	2740	2740	2740	2740	2740	2740
R3	8250	8250	8250	8250	8250	8250	8250	8250	8250	8250
R4	38360	38360	38360	38360	38360	38360	38360	38360	38360	38360
VOUT	15.15	15.3	15.45	15.6	15.75	15.9	16.05	16.2	16.35	16.5
R TRIM (50S)	247483	119617	76994	55683	42897	34372	28283	23717	20165	17323
R TRIM (100S)	123742	59808	38497	27842	21448	17186	14142	11858	10082	8662

APPLICATIONS MANUAL

Common Equations

Calculation of Input Current

Calculating the required current draw for your converter is as follows.

$$\text{Maximum Input current} = \frac{\frac{\text{Output Power}}{\text{Efficiency}}}{\text{Minimum Steady State Input Line}}$$

The above calculation will yield the converter's input current. For Example;

Model: NL50SM/5-C

Output Power: 50 watts

Steady State Line: 12 VDC

Efficiency; 78% at 12 VDC line, full load (see tables in Performance Characteristics) assuming 5% safety factor efficiency is then 73%

Steady State Input Line: 12 VDC

$$\text{Input Current} = \frac{\frac{50 \text{ watts}}{0.73}}{12 \text{ VDC}} \quad \text{Input Current} = 5.71 \text{ amps}$$

The worst case steady state input current to the NL series converter operating at full load with an input of 12 VDC is 5.71 amps.

Note: it is always best to be conservative. The figures for input voltage and efficiency should always include some additional margin for error.

Power Dissipation

The calculation of the total power dissipated from the converter will be essential for thermal management of the device. Unlike other types of electronic devices DC/DC converters tend to generate a significant amount of heat. This heat is channeled (by design) to the bottom or baseplate of the module. The following equations assist when designing a suitable heat sink.

The basic equation is;

$$P_{\text{Diss}} = P_{\text{in}} - P_{\text{out}}$$

Where P_{out} is defined as the maximum load condition and P_{in} is defined as a function of P_{out} and efficiency. The equation is therefore;

$$P_{\text{Diss}} = \left[\frac{P_{\text{out}}}{\text{Efficiency}} \right] - P_{\text{out}}$$

The energy loss calculated from the above equation will be dissipated via the converter's baseplate in the form of heat. A key parameter in this equation is the converter efficiency. Efficiency will be dependent upon the line and load characteristics of the application.

The above calculation will yield the converter's power dissipation. For example;

Model: NL150SM/5-C

Output Power: 150 watts

Efficiency; 78% at 12 VDC line, 100% load (see tables in Performance Characteristics) assuming 5% safety factor efficiency is then 73%

$$P_{\text{Diss}} = \left[\frac{150}{0.73} \right] - 150 \quad P_{\text{Diss}} = 55.48 \text{ watts}$$

B L O C K D I A G R A M

50 watt Channel(s)

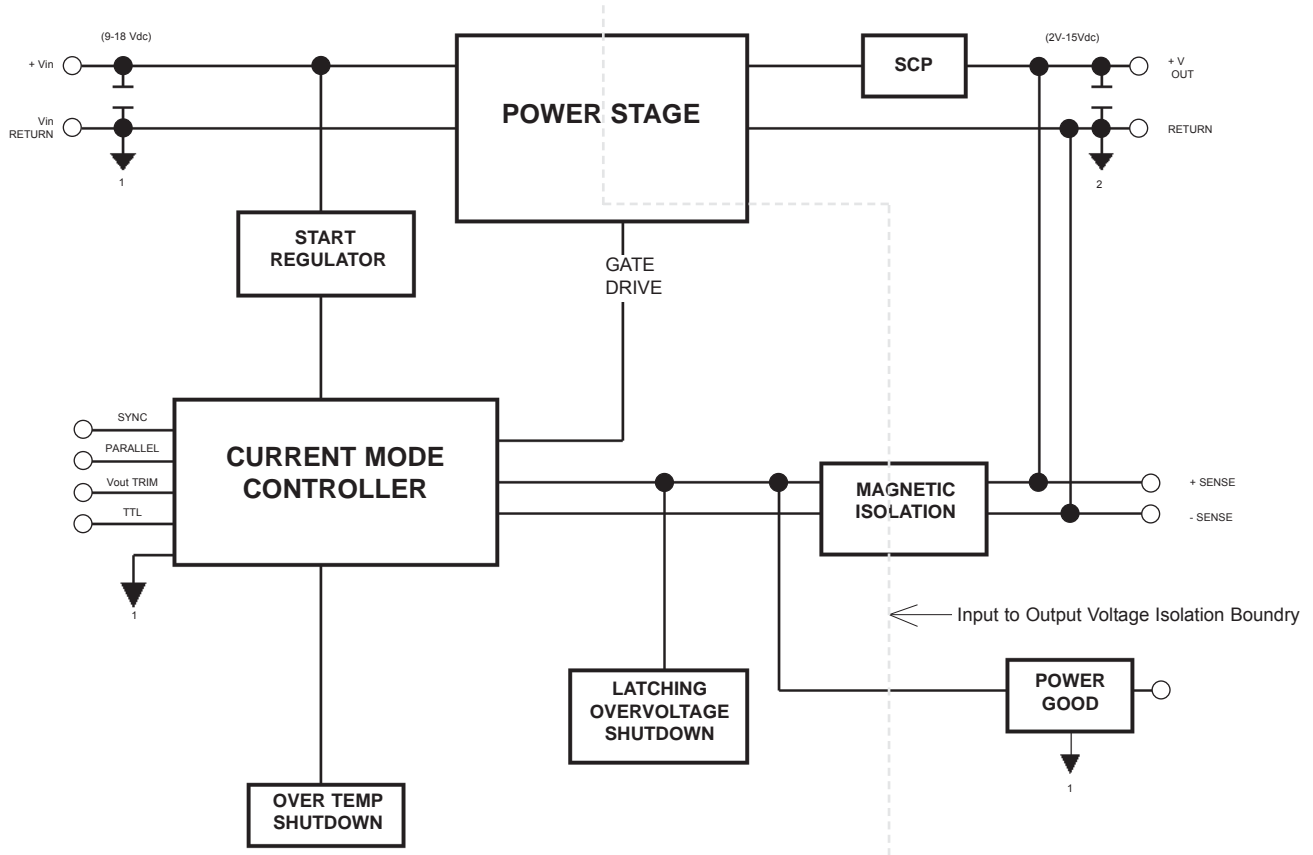

FREQUENTLY ASKED QUESTIONS

Q- Can I measure output voltage without any load connected to the unit?

A- Yes, all NL modules regulate to the specified output voltage under "no load" conditions.

Q- Can I connect the input ground to the output ground or to chassis ground?

A- Yes, the input, output and chassis grounds are isolated up 100 VDC minimum (see specification sheet) and may be tied together in any manner.

Q- Are any additional components required to operate the NL modules?

A- No, the NL series was designed for full operational performance without the need for additional components.

Q- Are any additional components recommended to enhance operation?

A- This will depend on your application. For noise sensitive systems we would recommend the use of bypass capacitors in parallel with the output leads of the converter (low ESR type). This will reduce the effects of noise on the output lines. For applications where the power source is located a significant distance away for the converter modules it may be desirable to add bypass capacitors in parallel with the input leads. Lastly, series operation clamping diodes can be included to protect against reverse voltage conditions (see series operation note in the applications section).

Q- At the output of the converter I have a hold up capacitor in parallel with my load. Will this cause a problem?

A- It might! Though a small amount of capacitance in parallel with the output will improve (reduce) noise performance, if the capacitor is too large it may cause the converter to trip its' over load protection circuit. If this happens it will appear as a "no output" condition. If you suspect that this is happening we suggest you remove the hold up capacitor from the line. The converter will then recover immediately.

Q- The module's output voltage drops to zero at high temperature but when the unit cools down the output returns. What's causing this problem?

A- The thermal protection circuit (described in the Over Temperature Protection section in the Guide to Operation) is engaging. This circuit will activate when the baseplate exceeds its maximum operating temperature (71°C for industrial and 100°C for military versions). To verify this you must measure the temperature at the center of the baseplate with a calibrated temperature probe. The center is the converter's "hot spot" and is the monitoring point for the thermal protection circuit. Measurements taken at other locations of the device will be lower by as much as 10°C. Also, be sure that the probe is securely in contact with the converter's base minimizing contact with any other thermally conductive material while taking the measurement.

Q- How many NL modules can be used with each EMI filter?

A- The NLF EMI filters are not specified for a maximum number of units but rather a maximum output power capability. As long as the total power draw does not exceed the filter rating the filter will perform to specification.

Q- If I don't want to use some of the features of the NL converter (TRIM, TTL, PAR, SYNC or POWER GOOD) do I still have to connect the pins?

A- No, for full operating performance all that needs to be connected is the two (2) input pins, the two to six (2/6) output pins (depending on output power) and the two to six (2/6) sense pins connected to either the load or the respective +/- output pins. You MUST connect all output pins provided to ensure reliable operation. The remaining pins may be left open (or cut for mounting purposes).

Q- I need to use an input EMI filter in front of the converter. Do you have a suggested circuit?

A- Abbott offers passive EMI filters (NLF modules) that are designed to operate in conjunction with our modules to provide compliance to Mil-Std-461D, conducted emissions (CE101 and CE102) on the input leads. Many customers have successfully designed their own filter however, we advise care when doing so. Any circuit between the power source and the input to the converter has the potential to cause operational problems (such as filter/converter oscillations). In addition, any components in line with the converter will cause a voltage drop and this must be taken into account when considering low line operation. For example, the input to the NL50 series converter is 9 to 18 VDC. When an NLF50 filter is added in line with the converter the low line input voltage at the input of the filter should be at least 10 VDC to account for the 1.0 VDC drop across the filter.

Q- What level of transient protection is the NL series capable of withstanding?

A- The converter alone can withstand a transient of 24 VDC for 100 mS.

STANDARD TERMS & CONDITIONS

Terms

Net 30 days from date of invoice.

Order Placement

Orders may be placed directly with Martek Power Abbott by mail, fax or telephone. Orders under \$1,000.00 on new accounts are COD or via VISA or American Express.

Taxes

All applicable VAT, Federal, State or local taxes are charged extra.

Freight

All prices listed are F.O.B. Factory, Los Angeles, California. Unless otherwise specified, shipment will be made via UPS Surface (for delivery in USA). The charges may vary by order but will generally be \$5 to \$10.00.

Insurance

Customers are liable for costs of insurance and transportation and for all import duties, taxes, licenses, clearance or other expenses required at the port of entry and destination.

Shipping and Delivery

All Martek Power Abbott power supplies are shipped complete with mounting hardware and printed instructions. Martek Power Abbott power modules are packaged for shipment per Interstate Commerce Commission Uniform Freight Classification Rules No. 40 and 41. Special military preservation and packaging is available upon request, at a modest additional cost.

Discrepancies in Delivery

It is the obligation of the customer to **notify Martek Power Abbott within ten days (of receipt)** of any obvious omissions or defects. Determination of responsibility will be made based on available information (i.e. shipping logs, carrier W/B, data, etc.)

Tax Identification Number

Martek Power Abbott's TIN number is 92-2137181.

Cage Code

Martek Power Abbott's cage code number is 15755.

Export Commodity Control Number (E.C.C.N.)

EAR99

WARRANTY & REPAIR INFORMATION

Warranty

Martek Power Abbott warranties each product manufactured by us, sold by us or our authorized agents, to be free from defects in material and workmanship, for the period states below for each product line. The Company shall, at its option, and as the Customer's and user's sole and exclusive remedy, issue a credit in the amount of the then applicable price of such product, or repair or replace any such product which is defective under the terms of the foregoing warranty, free of charge.

ALL OTHER EXPRESS, STATUTORY AND IMPLIED WARRANTIES, INCLUDING ALL IMPLIED WARRANTIES OF MERCHANTABILITY OR FITNESS FOR A PARTICULAR PURPOSE, ARE HEREBY DISCLAIMED. IN NO EVENT WILL THE COMPANY BE LIABLE FOR ANY INDIRECT, PUNITIVE, SPECIAL, INCIDENTAL OR CONSEQUENTIAL DAMAGE IN CONNECTION WITH OR RELATED TO THE SALE OF PRODUCTS.

I. Warranty of CB, NL, NH, NB, NW, and SM Series: CB, NL, NH, NW, NB, and SM Series are under a warranty period of three (3) years.

II. Warranty of ALL OTHER MODELS: All other models are under a warranty period of one (1) year.

Repair

I. Repair of CB, NL, NH, NB, NW, and SM Series: CB, NL, NH, NW, NB, and SM Series converters are covered under a three (3) year warranty. During this warranty period Martek Power Abbott will repair or replace (at Martek Power Abbott's discretion) all CB, NL, NH, NW, NB, and SM products found to be defective. CB, NL, NH, NW, NB, and SM Series converters which are out of warranty will not be repaired by Martek Power Abbott.

II. Repair of All other models: Martek Power Abbott will repair products covered by our warranty. To return products a Return Material Authorization (RMA) number is required. Products beyond the warranty will be repaired only after customer has authorized quoted repair charges. Any Martek Power Abbott products over seven (7) years old from date of original shipment will not be serviced or repaired.

Return Material Authorization Numbers

All returning goods must be accompanied by a Return Material Authorization (RMA) number. The RMA number must be clearly marked on the outside of the shipping carton. To receive an RMA number contact Martek Power Abbott at (310) 202-8820, ext. 276. Please be prepared with the correct model and serial number of the returning product. For out of warranty products a company purchase order will be required for processing.

Evaluation Charges

All out of warranty products returned to Martek Power Abbott are subject to a \$50.00 evaluation charge. If the returned product is found to be in need of repair, and these repairs are authorized, the \$50.00 evaluation will be waived.

Repair Charges

Repair charges for all models are quoted per Martek Power Abbott's published repair price list. The repair charges do not include any additional processing or testing fees (i.e. ESS testing).

Shipping Instructions

All returning goods must have a Return Material Authorization (RMA) number marked on the carton. The number should be marked on a minimum of 2 sides of the carton, 3 inches (76mm) high, 6 inches (152mm) long. All goods must be shipped prepaid. Martek Power Abbott reserves the right to refuse all shipments received without a Return Material Authorization (RMA) number.



M A R T E K P O W E R

With a worldwide network of design and manufacturing facilities, Martek Power is firmly established as a global leader in the development, manufacture and technical support of a broad range of innovative standard, semi-custom and custom power conversion products.



Over 1,500,000 products per year are shipped to more than 3,000 customers in markets as diverse as data processing, telecommunications, data networking, computer peripherals, aerospace, process control, military, medical and instrumentation.



With seven operating divisions located worldwide, Martek Power has the proximity to offer unparalleled local service, tailored to the needs of individual customers. Over 1,400 highly skilled employees (including 100 in R&D) are employed at ISO 9001:2000 registered manufacturing facilities in Europe, the United States, Mexico and China.

Martek Power offers one of the widest range of power conversion products in the industry. Products range from AC/DC switching power supplies, to uninterruptible power supplies, to DC/DC converter modules, to chargers. We provide cost-effective solutions to any customer power requirement whether it requires an “off-the-shelf” standard product or a semi-custom or full custom design.

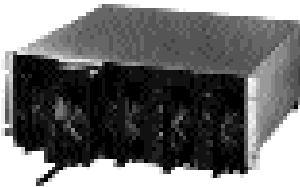

Martek Power satisfies low volume “quick-turn” requirements as well as the rigorous demands of high volume OEM applications. We have the technical experience, manufacturing capacity, comprehensive product offering and total commitment to quality to be a true partner in the development of all your power system needs.



www.martekpower.com