



## Index

<b>Adapters</b> .....	<b>Page</b>
18 GHz (N to SMA) .....	67
27 GHz (Super SMA) .....	68
33 GHz (3.5 mm to 2.40 mm) .....	69
40 GHz (2.92 mm “JK”).....	70
40 GHz (2.92 mm to 2.40 mm) .....	71
40 GHz (SSMA to 2.40 mm) .....	72
50 GHz (2.40 mm) .....	73

*Southwest Microwave Adapters are considered in-between metrology and instrument grades.  
Our adapters would best be described as “Precision Grade” which are ideally suited for production tests.*

### N to Super SMA Adapters

#### DC to 18.0 GHz

#### Application:

- DC to 18.0 GHz High Performance

#### Features:

- Mode Free Through 18.0 GHz.
- Low VSWR:  
DC to 18.0 GHz.....1.15:1 max.
- Performance Consistency Unit-to-unit
- Temperature Rating -55°C to +165°C

#### Interface:

- Per MIL-STD-348  
SMA Figs. 310-1 and 310-2  
N Figs. 304-1 and 304-2

#### Construction:

- Housing: Stainless Steel, Passivated
- Contact: Beryllium Copper (BeCu)  
Gold Plated Per MIL-G-45204
- Dielectric:  
PTFE Fluorocarbon Per ASTM D 1457
- Center Contact Capture:  
Ultem 1000 Per ASTM D 5205

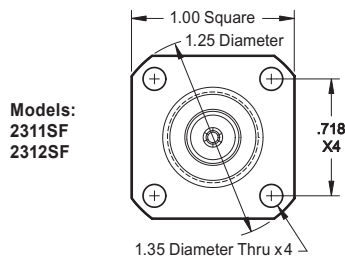

N to SMA Adapter (Model # 2320SF) Test Data

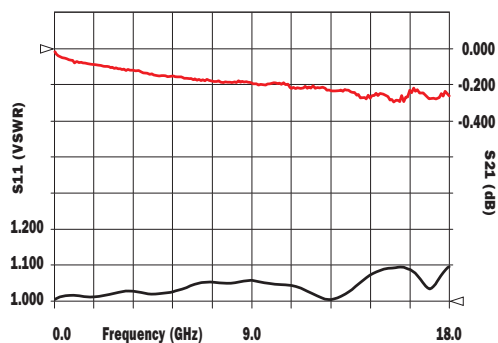

#### N (f) to SMA (f)

(18 GHz)



Model 2310SF

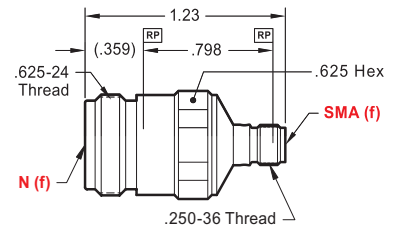

#### N (m) to SMA (f)

(18 GHz)



Model 2320SF

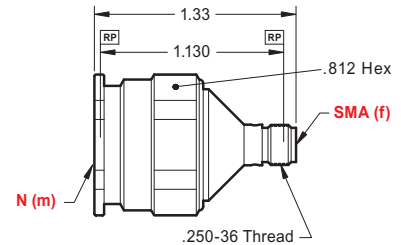

#### N (f) to SMA (m)

(18 GHz)



Model 2330SF

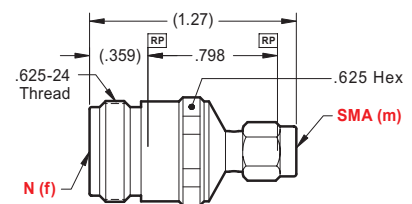

#### N (m) to SMA (m)

(18 GHz)



Model 2340SF

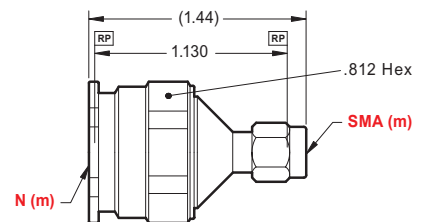

#### N (f) to SMA (m)

(18 GHz)



Model 2311SF

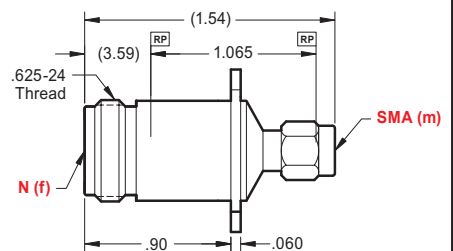

#### N (f) to SMA (f)

(18 GHz)



Model 2312SF

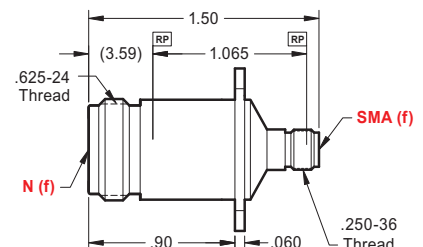

All Southwest Microwave Models are Suitable for Space / Hi-Rel Applications (see page 109).

### Super SMA Adapters

DC to 27.0 GHz

**Application:**

- DC to 27.0 GHz High Performance

**Features:**

- Mode Free Through 27.0 GHz.
- Low VSWR:  
DC to 18.0 GHz.....1.10:1 max.  
18.0 to 27.0 GHz.....1.15:1 max.
- Minimum VSWR Contribution When Used as Connector Savers
- Performance Consistency Unit-to-unit
- Temperature Rating -55°C to +165°C

**Interface:**





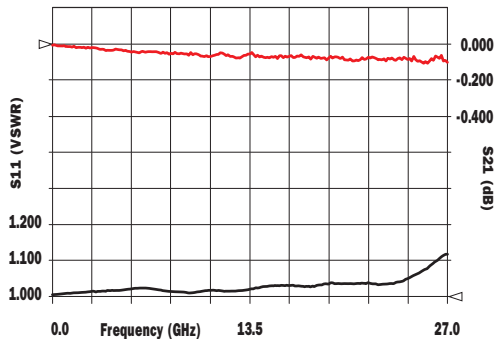

- Per MIL-STD-348  
SMA Figs. 310-1 and 310-2

**Construction:**

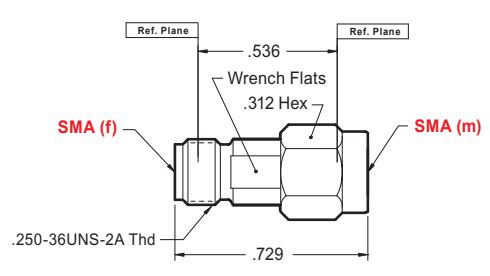
- Housing: Stainless Steel, Passivated
- Contact: Beryllium Copper (BeCu)  
Gold Plated Per MIL-G-45204
- Dielectric:  
PTFE Fluorocarbon Per ASTM D 1457
- Center Contact Capture:  
Ultem 1000 Per ASTM D 5205

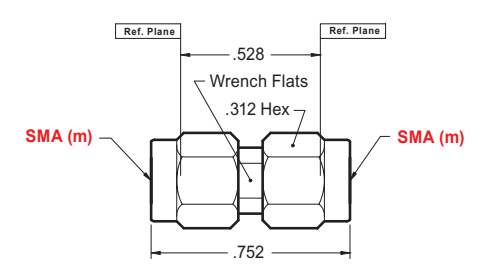
Super SMA Adapter (Model # 232-502SF) Test Data

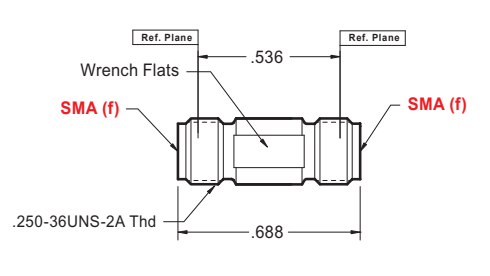

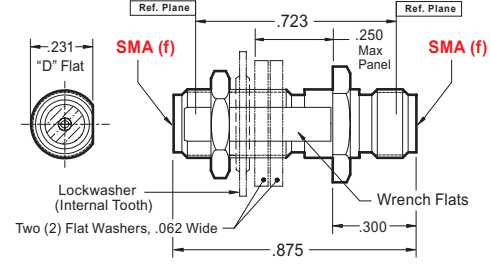
<p><b>SMA (m) to (f)</b> (27 GHz)</p>  <p><b>Model 230-506SF</b></p>	
<p><b>SMA (m) to (m)</b> (27 GHz)</p>  <p><b>Model 231-502SF</b></p>	
<p><b>SMA (f) to (f)</b> (27 GHz)</p>  <p><b>Model 232-502SF</b></p>	
<p><b>SMA (f) to (f)</b> Bulkhead (27 GHz)</p>  <p><b>Model 232-510SF</b></p>	

All Southwest Microwave Models are Suitable for Space / Hi-Rel Applications (see page 109).

### 3.5 mm to 2.40 mm

#### DC to 33.0 GHz

#### Application:

- DC to 33.0 GHz High Performance

#### Features:

- Mode Free Through 33.0 GHz.
- Low VSWR:  
DC to 27.0 GHz.....1.10:1 max.  
27.0 to 33.0 GHz.....1.15:1 max.
- Performance Consistency Unit-to-unit
- Temperature Rating -55°C to +135°C

#### Interface:





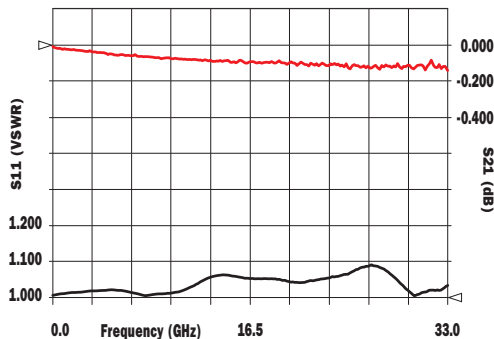

- Per MIL-STD-348  
2.40 mm Figs. 324-1 and 324-2  
3.5 mm Ref IEEE Std 287

#### Construction:

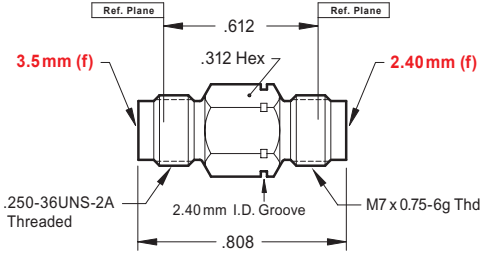
- Housing: Stainless Steel, Passivated
- Contact: Beryllium Copper (BeCu)  
Gold Plated Per MIL-G-45204
- Center Contact Capture:  
Ultem 1000 Per ASTM D 5205  
and KEL-F Per ASTM D 1430

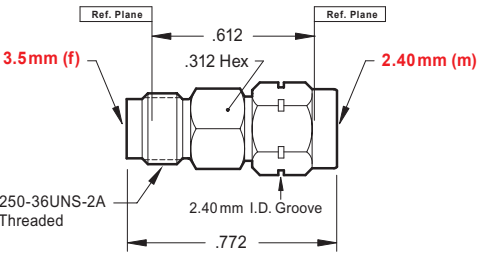
3.5 mm to 2.40 mm (Model # 61420-00SF) Test Data

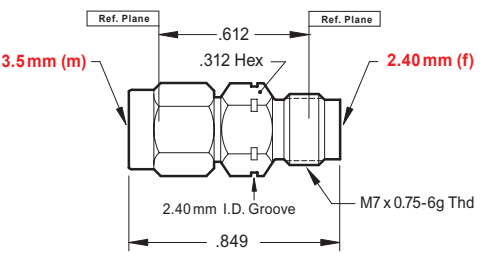

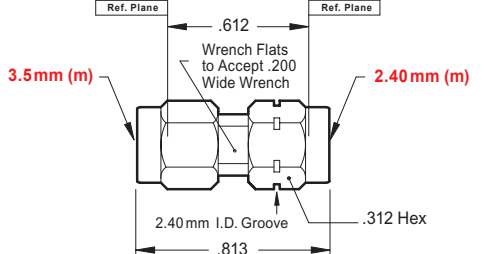
<p><b>3.5 mm (f) to 2.40 mm (f)</b> (33 GHz)</p>  <p><b>Model 61410-00SF</b></p>	 <p>Ref. Plane .612 Ref. Plane 3.5 mm (f) .312 Hex 2.40 mm (f) .250-36UNS-2A Threaded 2.40 mm I.D. Groove M7 x 0.75-6g Thd .808</p>
<p><b>3.5 mm (f) to 2.40 mm (m)</b> (33 GHz)</p>  <p><b>Model 61420-00SF</b></p>	 <p>Ref. Plane .612 Ref. Plane 3.5 mm (f) .312 Hex 2.40 mm (m) .250-36UNS-2A Threaded 2.40 mm I.D. Groove .772</p>
<p><b>3.5 mm (m) to 2.40 mm (f)</b> (33 GHz)</p>  <p><b>Model 61430-00SF</b></p>	 <p>Ref. Plane .612 Ref. Plane 3.5 mm (m) .312 Hex 2.40 mm (f) 2.40 mm I.D. Groove M7 x 0.75-6g Thd .849</p>
<p><b>3.5 mm (m) to 2.40 mm (m)</b> (33 GHz)</p>  <p><b>Model 61440-00SF</b></p>	 <p>Ref. Plane .612 Ref. Plane 3.5 mm (m) Wrench Flats to Accept .200 Wide Wrench 2.40 mm (m) 2.40 mm I.D. Groove .312 Hex .813</p>

All Southwest Microwave Models are Suitable for Space / Hi-Rel Applications (see page 109).

### 2.92 mm "JK" Adapters

#### DC to 40.0 GHz

#### Application:

- DC to 40.0 GHz High Performance

#### Features:

- Mode Free Through 40.0 GHz.
- Low VSWR:  
DC to 27.0 GHz.....1.10:1 max.  
27.0 to 40.0 GHz.....1.15:1 max.
- Minimum VSWR Contribution When Used as Connector Savers
- Performance Consistency Unit-to-unit
- Temperature Rating -55°C to +135°C

#### Interface:

- Per MIL-STD-348  
2.92 mm (SMK) Figs. 323-1 and 323-2

#### Construction:

- Housing: Stainless Steel, Passivated
- Contact: Beryllium Copper (BeCu)  
Gold Plated Per MIL-G-45204
- Center Contact Capture:  
Ultem 1000 Per ASTM D 5205  
and KEL-F Per ASTM D 1430

2.92 mm to 2.92 mm (Model # 1031-00SF) Test Data

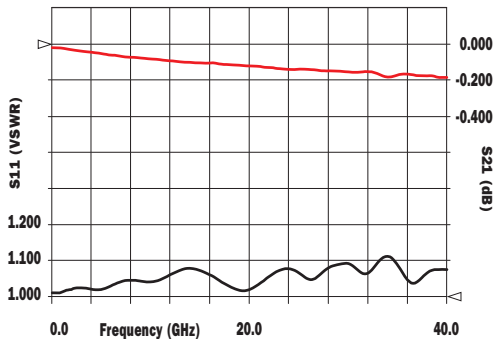

2.92 mm (f) to (m)  
(40 GHz)



Model 1030-00SF

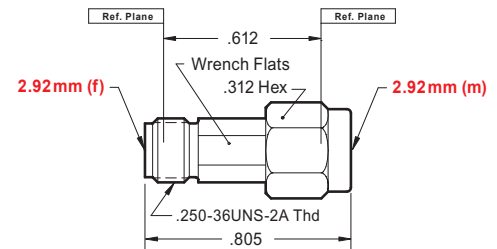

2.92 mm (m) to (m)  
(40 GHz)



Model 1031-00SF

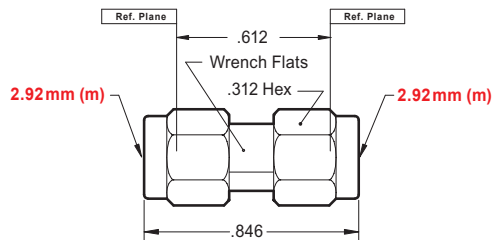

2.92 mm (f) to (f)  
(40 GHz)



Model 1032-00SF

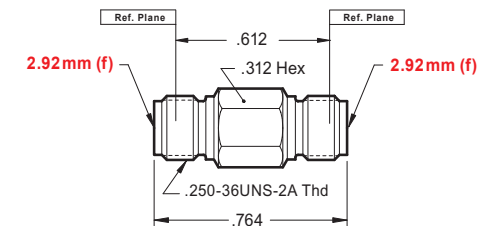

2.92 mm (f) to (m)  
Bulkhead  
(40 GHz)



Model 1030-10SF

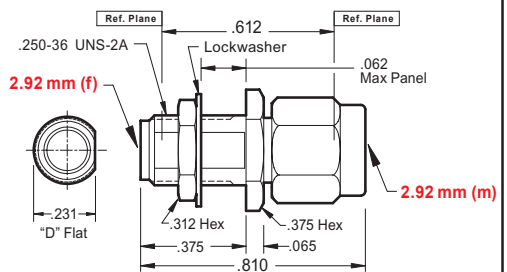

2.92 mm (f) to (f)  
Bulkhead  
(40 GHz)



Model 1032-10SF

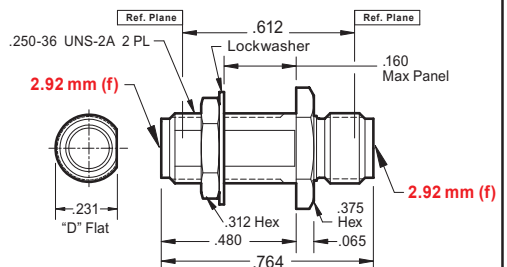

All Southwest Microwave Models are Suitable for Space / Hi-Rel Applications (see page 109).

### 2.92 mm to 2.40 mm

DC to 40.0 GHz

**Application:**

- DC to 40.0 GHz High Performance

**Features:**

- Mode Free Through 40.0 GHz.
- Low VSWR:  
DC to 27.0 GHz.....1.10:1 max.  
27.0 to 40.0 GHz.....1.15:1 max.
- Performance Consistency Unit-to-unit
- Temperature Rating -55°C to +135°C

**Interface:**





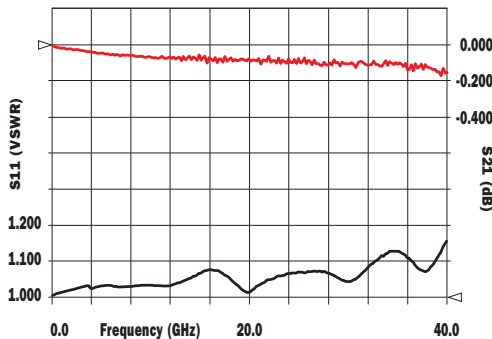

- Per MIL-STD-348  
2.92 mm (SMK) Figs. 323-1 and 323-2  
2.40 mm Figs. 324-1 and 324-2

**Construction:**

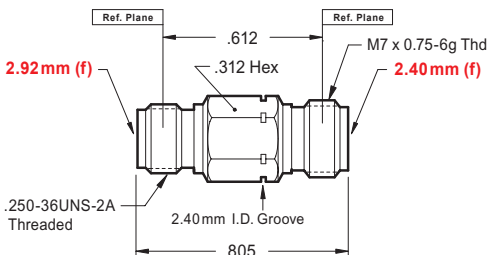
- Housing: Stainless Steel, Passivated
- Contact: Beryllium Copper (BeCu)  
Gold Plated Per MIL-G-45204
- Center Contact Capture:  
Ultem 1000 Per ASTM D 5205  
and KEL-F Per ASTM D 1430

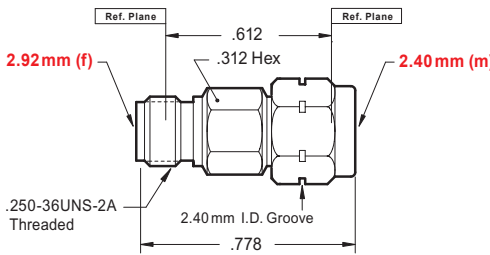
2.92 mm to 2.40 mm (Model # 101430-00SF) Test Data

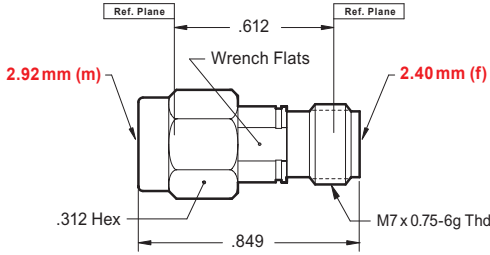

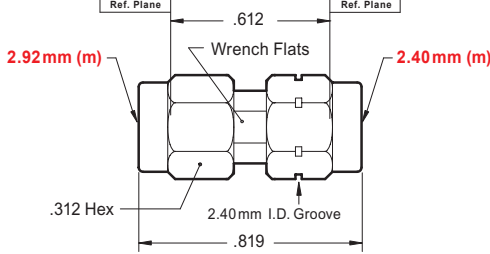
<p><b>2.92 mm (f) to 2.40 mm (f)</b> (40 GHz)</p>  <p><b>Model 101410-00SF</b></p>	
<p><b>2.92 mm (f) to 2.40 mm (m)</b> (40 GHz)</p>  <p><b>Model 101420-00SF</b></p>	
<p><b>2.92 mm (m) to 2.40 mm (f)</b> (40 GHz)</p>  <p><b>Model 101430-00SF</b></p>	
<p><b>2.92 mm (m) to 2.40 mm (m)</b> (40 GHz)</p>  <p><b>Model 101440-00SF</b></p>	

All Southwest Microwave Models are Suitable for Space / Hi-Rel Applications (see page 109).

### SSMA (Airline) to 2.40 mm

DC to 40.0 GHz

**Application:**

- DC to 40.0 GHz High Performance

**Features:**

- Mode Free Through 40.0 GHz.
- Low VSWR:  
DC to 27.0 GHz.....1.10:1 max.  
27.0 to 40.0 GHz.....1.15:1 max.
- Performance Consistency Unit-to-unit
- Temperature Rating -55°C to +135°C

**Interface:**





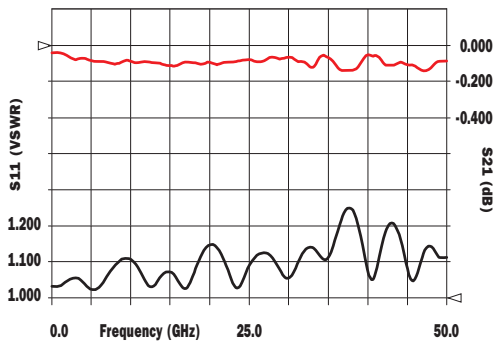

- Per MIL-STD-348  
SSMA Figs. 319-1 and 319-2  
2.40 mm Figs. 324-1 and 324-2

**Construction:**

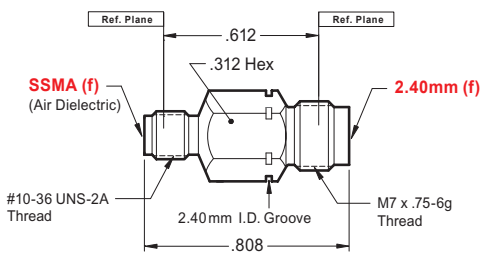
- Housing: Stainless Steel, Passivated
- Contact: Beryllium Copper (BeCu)  
Gold Plated Per MIL-G-45204
- Center Contact Capture:  
Ultem 1000 Per ASTM D 5205  
and KEL-F Per ASTM D 1430

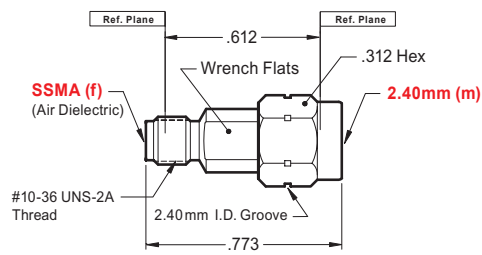
**SSMA (Airline) to 2.4 mm**  
(Model # 11430-00SF) Test Data

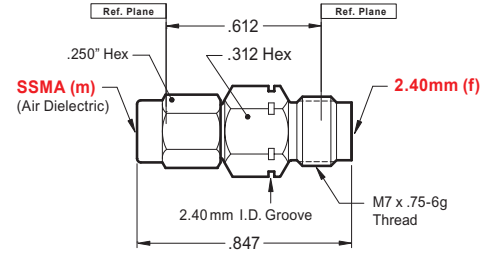

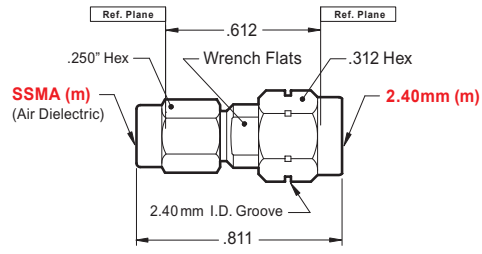
<p><b>SSMA (f) to 2.40 mm (f)</b> (40 GHz)</p>  <p><b>Model 11410-00SF</b></p>	 <p>Ref. Plane .612 Ref. Plane SSMA (f) (Air Dielectric) .312 Hex 2.40mm (f) #10-36 UNS-2A Thread 2.40 mm I.D. Groove M7 x .75-6g Thread .808</p>
<p><b>SSMA (f) to 2.40 mm (m)</b> (40 GHz)</p>  <p><b>Model 11420-00SF</b></p>	 <p>Ref. Plane .612 Ref. Plane SSMA (f) (Air Dielectric) Wrench Flats .312 Hex 2.40mm (m) #10-36 UNS-2A Thread 2.40 mm I.D. Groove .773</p>
<p><b>SSMA (m) to 2.40 mm (f)</b> (40 GHz)</p>  <p><b>Model 11430-00SF</b></p>	 <p>Ref. Plane .612 Ref. Plane SSMA (m) (Air Dielectric) .250° Hex .312 Hex 2.40mm (f) 2.40 mm I.D. Groove M7 x .75-6g Thread .847</p>
<p><b>SSMA (m) to 2.40 mm (m)</b> (40 GHz)</p>  <p><b>Model 11440-00SF</b></p>	 <p>Ref. Plane .612 Ref. Plane SSMA (m) (Air Dielectric) .250° Hex Wrench Flats .312 Hex 2.40mm (m) 2.40 mm I.D. Groove .811</p>

### 2.40 mm Adapters

#### DC to 50.0 GHz

#### Application:

- DC to 50.0 GHz High Performance

#### Features:

- Mode Free Through 50.0 GHz.
- Low VSWR:  
DC to 27.0 GHz.....1.10:1 max.  
27.0 to 40.0 GHz.....1.15:1 max.  
40.0 to 50.0 GHz.....1.20:1 max.
- Minimum VSWR Contribution  
When Used as Connector Savers
- Performance Consistency Unit-to-unit
- Temperature Rating -55°C to +135°C

#### Interface:

- Per MIL-STD-348  
2.40 mm Figs. 324-1 and 324-2

#### Construction:

- Housing: Stainless Steel, Passivated
- Contact: Beryllium Copper (BeCu)  
Gold Plated Per MIL-G-45204
- Center Contact Capture:  
Ultem 1000 Per ASTM D 5205  
and KEL-F Per ASTM D 1430

#### 2.40 mm (f) to (m) (50 GHz)



**Model 1430-00SF**

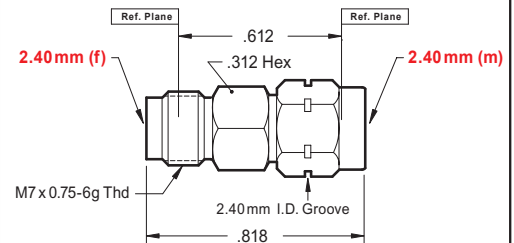

#### 2.40 mm (m) to (m) (50 GHz)



**Model 1431-00SF**

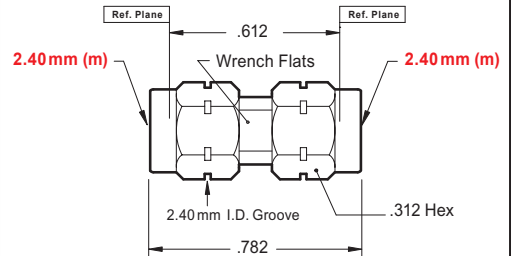

#### 2.40 mm (f) to (f) (50 GHz)



**Model 1432-00SF**

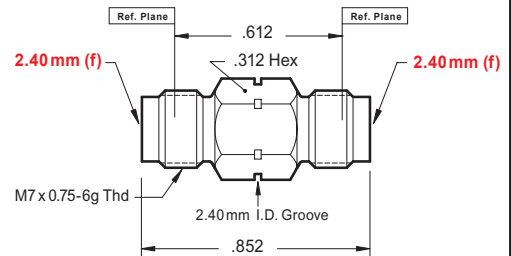

**2.40 mm to 2.40 mm (Model # 1431-00SF) Test Data**

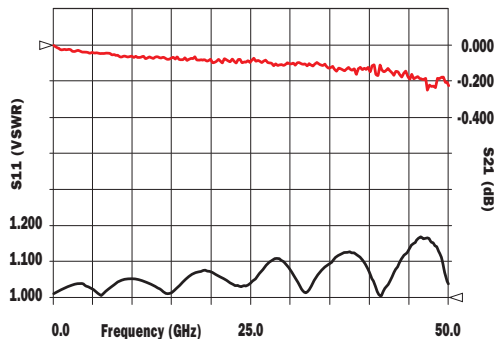

All Southwest Microwave Models are Suitable for Space / Hi-Rel Applications (see page 109).