

AP1511A / B

IR Filter Switch Driver with one-shot output for IR-Cut Removable (ICR)

ANAPEX TECHNOLOGY INC.
3F-1, No. 87-1, Guangming 6th Rd.,
Jhubei City, Hsinchu 30268,
Taiwan, R.O.C.

Tel: +886-3-6570696
Fax: +886-3-6570692

Agent:

Version: 1.2
May. 7, 2012

This article is subject to change without notice.

FEATURES

- 1.8V 输入电平
- 低饱和电压 (0.73V@300mA, VDD=5V)
- 低待机电流 (<10uA)
- 操作电压 2.5V 至 5.5V
- 6 管脚 SOT-26 包装
- 只需单一输入即可控制

APPLICATIONS

- IR-Cut Removable (ICR) 专用驱动 IC.

DESCRIPTION

AP1511 是一款专为 IR-Cut Removable (ICR) 设计的驱动 IC 用来开关红外线滤光片. AP1511 具有一个低饱和电压双向的 H-bridge 驱动电路. 内建保护二极管疏通 ICR 所产生的的反馈电流, 以及防止 ESD 的破坏.

AP1511 内的双向 H-bridge 驱动电路其内阻小于 3 欧姆, 所以 ICR 模块所需的电流决定于其线圈的阻抗. 以工作电源 5 伏特为例, 当 ICR 内部线圈流过 300mA 电流时, AP1511 内的 H-bridge 驱动电路会产生 0.73V 的压降.

AP1511A 提供单线控制与双线控制, 而 AP1511B 以单线控制并且提供单步操作(One-Shot)的功能.

PIN CONFIGURATION

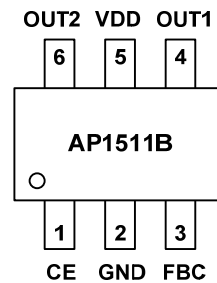
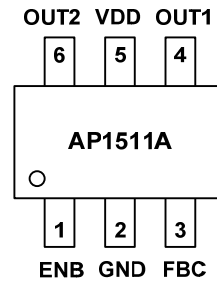

Pin #	Mnemonic	I/O	Description
1	ENB	I	Low-active enable
	CE	I	External capacitor
2	GND	-	Ground
3	FBC	I	Forward/Backward control
4	OUT1	O	Driver output 1
5	VDD	-	Power supply
6	OUT2	O	Driver output 2

ORDERING INFORMATION

MODEL	PACKAGE
AP1511A	SOT-26
AP1511B	SOT-26

Absolute Maximum Ratings (unless otherwise specified, Temperature=25°C)

Characteristic	Symbol	Rating	Unit
Supply Voltage	VDD	5.5	V
Input Voltage	VIN	VDD+0.4V	V
Output Current (Continue)	IOUT	500	mA
(Pulse, 50% duty)		600	mA
Operating Temperature Range	TOPR	-40~125	°C
Storage Temperature Range	TSTO	-65~150	°C

Electrical Characteristics (unless otherwise specified, Temperature=25°C & VDD=5.0V)

Characteristic	Sym.	Condition	Limit			Unit
			Min.	Typ.	Max.	
Supply Voltage	VDD	-	2.5	5.0	5.5	V
Supply Current	ISTB(A)	Steady state or standby state version A	-	-	20	µA
	ISTB(B)	Steady state or standby state version B	-	-	10	µA
	IDD	Transit state	0.8	1	1.2	mA
Driver input control ENB/FBC						
Input High "H"	VIH	-	1.6	-	VDD+0.4	V
Input High "L"	VIL	-	-0.4	-	0.2*VDD	V
Driver output OUT1/OUT2						
Output Voltage (upper + lower)	VOUT1	IOUT = 200 mA	-	0.42	-	V
	VOUT2	IOUT = 300 mA	-	0.73	-	V
	VOUT3	IOUT = 400 mA	-	1.03	-	V
Rise transition time	TR	From 0.1*VDD to 0.9*VDD	-	2.5	5	ns
Fall transition time	TF	From 0.9*VDD to 0.1*VDD	-	3.5	7	ns

Characteristic	Sym.	Condition	Limit			Unit
Propagation Delay Time						
ENB → OUT1 / 2 (“L” to “H”)	t_{pLH}	VDD = 5V, Load = 18	-	13	16	ns
ENB → OUT1 / 2 (“H” to “L”)	t_{pHL}		-	36	43	ns
Pulse Width of ENB	t_{PW}		100	-	-	ns
Maximum frequency of ENB	f_{MAX}		-	-	5	MHz

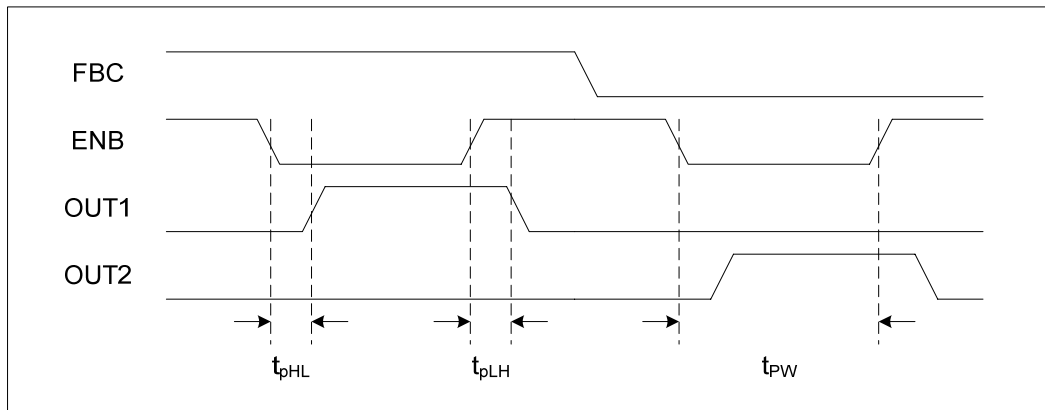

Propagation delay time between ENB and OUT1/2

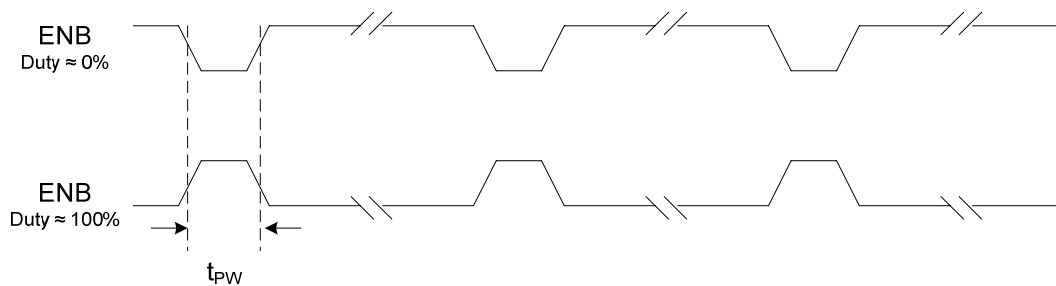

PWM waveform for ENB

Typical Application (AP1511A)

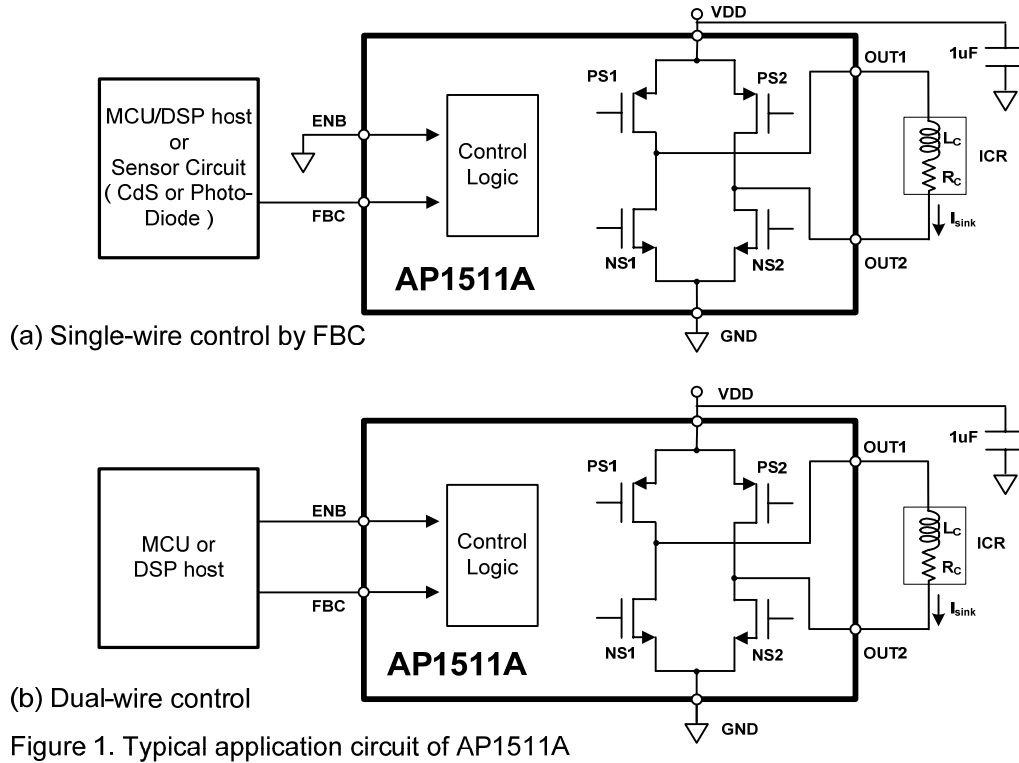
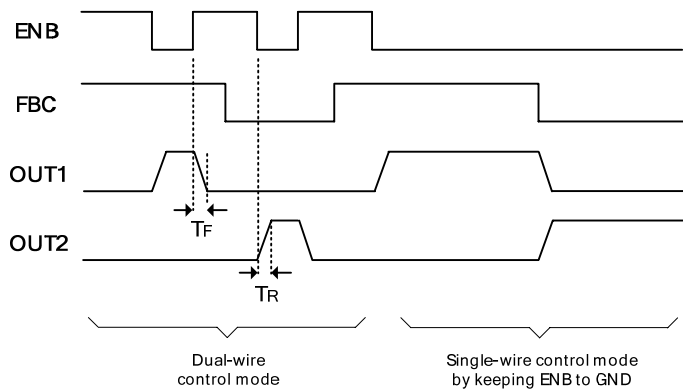

Figure 1. Typical application circuit of AP1511A

Truth Table and Diagram of Controls

Input		Output	
ENB	FBC	OUT1	OUT2
H	X	L	L
L	H	H	L
L	L	L	H



Typical Application (AP1511B)

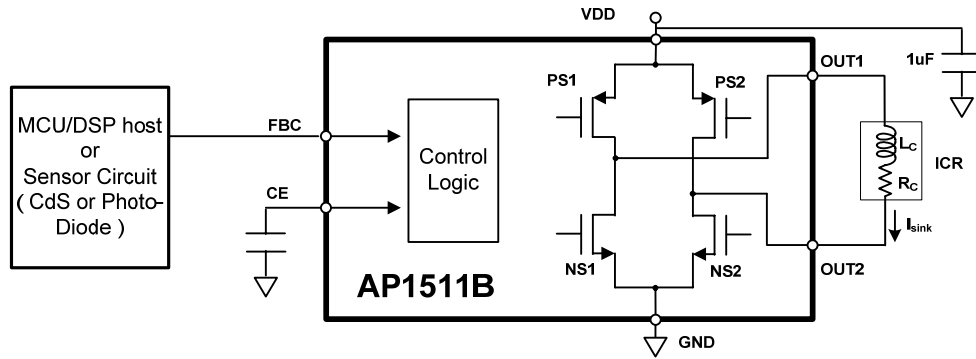
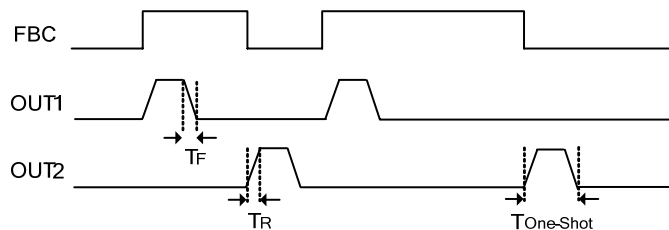

Figure 2. Typical application circuit of AP1511B

Truth Table and Diagram of Controls

Input	Output	
	OUT1	OUT2
FBC	OUT1	OUT2



$T_{\text{One-Shot}}$ 的长度是由接在 CE 管脚上的外部电容所决定. 其关系式为

$$T_{\text{One-Shot}} = 1.3 \times 10^6 \times C_{\text{CE}} \text{ (second)}$$

当外部电容容值固定时, IC 温度每上升 1°C , $T_{\text{One-Shot}}$ 会减少 0.2% . 事实上一般的电容容值也会随温度变化, 25°C 时电容值为最大, 偏离 25°C 后电容值会减小. 因此建议将 $T_{\text{One-Shot}}$ 设定为 ICR 所需时间的两倍, 使得在任意温度下皆可以正常动作.

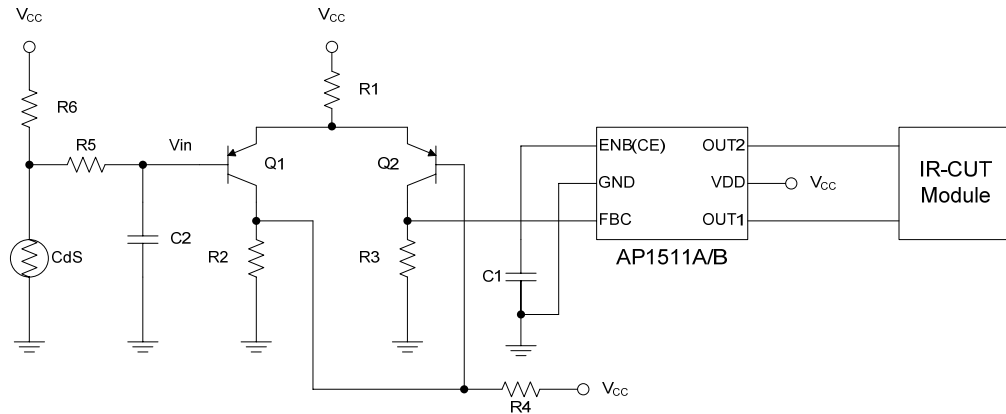

上图为一个AP1511A/B的应用线路图。光敏电阻CdS R5与R6组成光感测电路，其输出接至延迟电路R5以及C2。Vin的电压大小即为目前的环境亮度。史密特触发电路（Q1, Q2 and R1~R4）用来判断目前为白天或是晚上并且控制AP1511A/B FBC管脚的方向。这样ICR模块中红外线绿光片的位置就会根据环境的亮度来做变动。

延迟电路的作用是为了确保亮度信号稳定，不会因为环境亮度瞬间改变所干扰。当 $R5 = 200k$ 以及 $C2 = 22\mu F$ 时延迟时间约为 3 秒。所以当环境亮度变化后必须超过 3 秒，AP1511 才会动作，否则将视为干扰 AP1511 不会动作。

史密特触发电路利用两个临界电压 (V_{IH} 与 V_{IL}) 来得到较好的噪声容忍度以避免环境干扰。当 Vin 低于 V_{IL} 时，史密特触发电路将送出低电平至 FBC 管脚。当 Vin 高于 V_{IH} 时，史密特触发电路将送出高电平至 FBC 管脚。Vin 电压如果介于 V_{IH} 与 V_{IL} 时，史密特触发电路输出电平不会改变。此一特性可以提高噪声容忍度并且消除干扰。

临界电压可以由 R1~R4 电阻阻值来决定。可以利用安沛科技所提供的应用程序“Schmitt Trigger Calculator”来做计算。

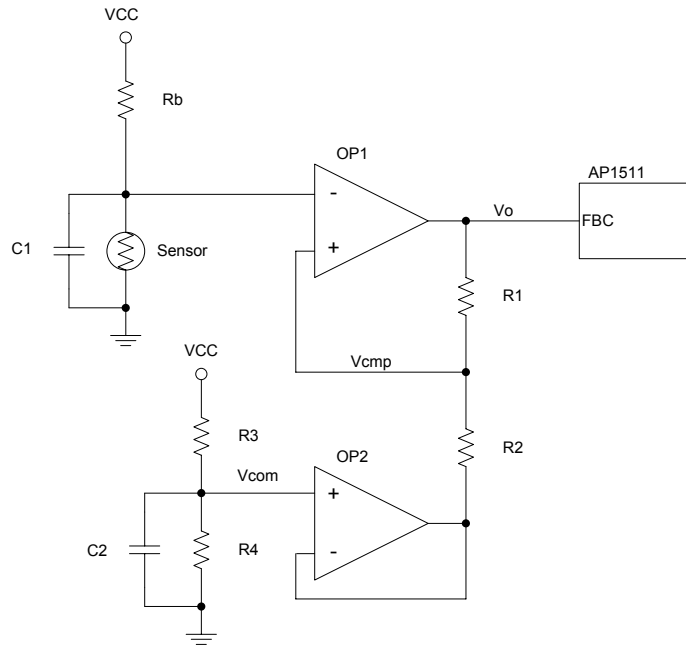

$$V_{cmp_H} = \frac{R2}{R1 + R2} V_{cc} + \frac{R1}{R1 + R2} V_{com} \quad (V_o = V_{cc})$$

$$V_{cmp_L} = \frac{R2}{R1 + R2} \cdot 0 + \frac{R1}{R1 + R2} V_{com} = \frac{R1}{R1 + R2} V_{com} \quad (V_o = GND)$$

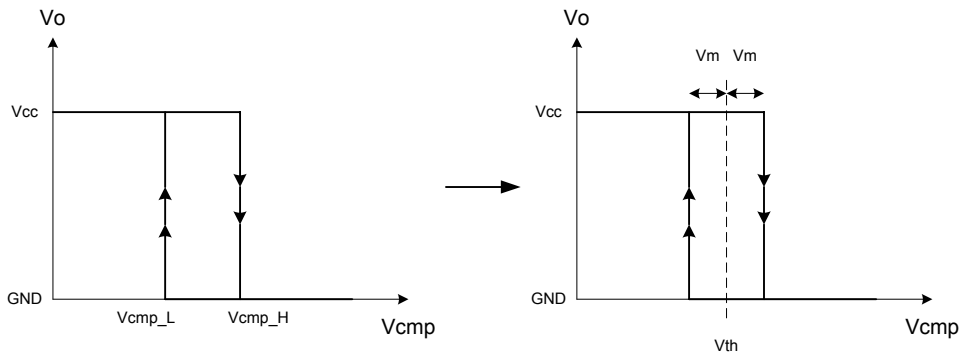

$$V_{th} = (V_{cmp_H} + V_{cmp_L}) / 2 = \frac{R2}{2(R1 + R2)} V_{cc} + \frac{R1}{R1 + R2} V_{com}$$

$$V_m = (V_{cmp_H} - V_{cmp_L}) / 2 = \frac{R2}{2(R1 + R2)} V_{cc}$$

上列公式说明 OPAMP 组成之史密特触发电路的 V_{th} 以及 V_m 如何计算，其电压值可以由 $R1$ 与 $R2$ 决定。当输入讯号高于 V_{cmp_H} 或低于 V_{cmp_L} 时，史密特触发电路的输出会改变。此一特性可以提高噪声容忍度并且消除干扰。

AP1511 的 ENB 与 FBC 管脚为高阻抗输入, 没有内含提升电阻. 大部分的情况下, AP1511 由 MCU 或 HOST CPU 的 GPIO 所控制. GPIO 有两种形式三态输出(tri-states output)与开极输出(open-drain output).

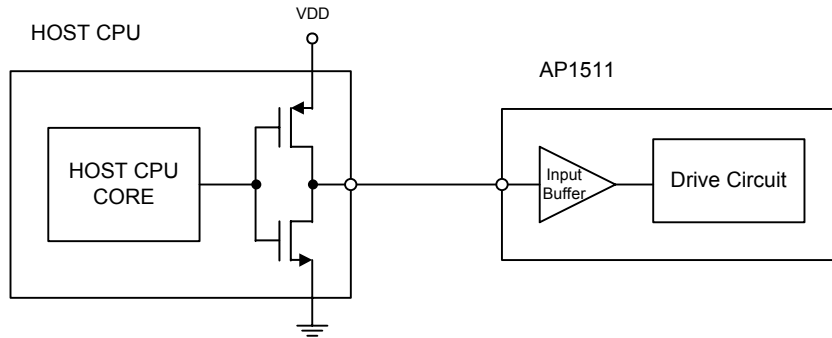

HOST CPU with tri-state output buffer

因为 tri-state output 可以送出高电平 VDD 与低电平 GND. 所以此一种 GPIO 直接接到 AP1511 的 ENB 与 FBC 管脚即可.

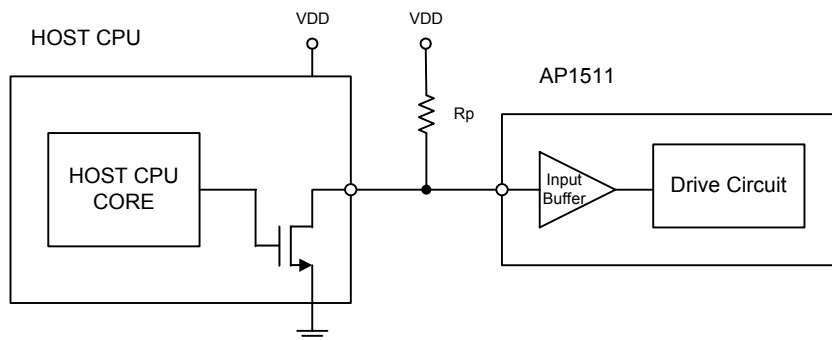

Host CPU with open-drain output buffer

若是 open-drain output 其只能输出低电平 GND, 所以必须在 GPIO 上加一个提升电阻 R_p 来产生高电平 VDD. 此一提升电阻 R_p 的阻值约在数百 k 即可. 较小的提升电阻可以得到较快得上升时间, 但是当 GPIO 输出低电平时会较耗电.

OUTLINE DIMENSION (SOT-26)

View from Top Side

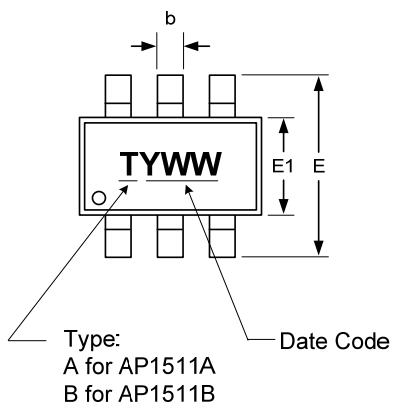

View from Bottom Side

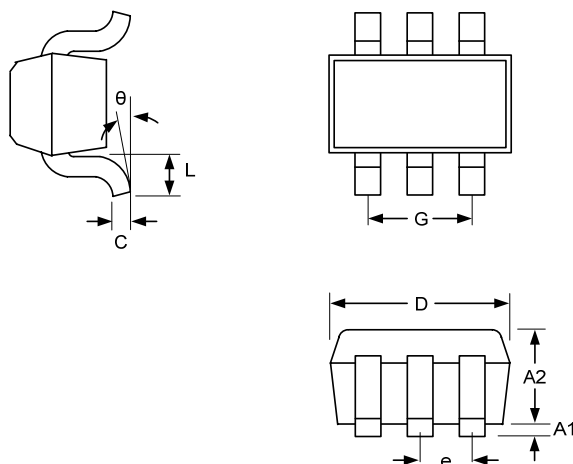

SYMBOLS	DIMENSION (MM)			DIMENSION (MIL)		
	MIN	NOM	MAX	MIN	NOM	MAX
A1	0.02	0.05	0.1	0.80	2.00	4.00
A2	1.00	1.10	1.30	40.0	44.0	52.0
b	0.35	0.38	0.45	14.0	15.0	18.0
C	0.10	0.15	0.20	4.0	6.0	8.0
D	2.90	3.00	3.10	116	120	124
E	2.70	2.80	3.00	108	112	120
E1	1.50	1.60	1.70	60.0	64.0	68.0
e	0.95			38		
G	1.90			76		
L	0.35	0.40	0.55	14.0	16.0	22.0
θ	0°	8°	-	0°	8°	-