

Data Sheet

- ITEM : COMMON MODE ESD FILTER
- PART NO : ICMEF112P900MFR

ITEM	P/N	Page
COMMON MODE ESD FILTER	ICMEF112P900MFR	2

1. Generals

- This specification covers the engineering requirements for the ICMEF112P900M (Common Mode ESD Filter)

2. Features

- Effective for suppressing common mode noise and almost no effect for high speed differential data line
- One common mode filters and two ESD suppression devices integrated
- Ultra low profile (1.27 x 1.00 x 0.60mm)
- Ceramic multilayer type SMD component
- Non-polarized product
- It is a product conforming to RoHS directive.

3. Applications

- LVDS lines in notebook computers
- USB2.0, IEEE1394, DVI, HDMI lines in PDP, LCD TV, DVD Player, PC, Audio player, DSC
- MDDI, MIPI in mobile phone

4. Product specifications

4. 1 PART NUMBER CODE

ICMEF 11 2P 900 M F R
 ① ② ③ ④ ⑤ ⑥ ⑦

- ① Series name of ICT's Common Mode ESD Filter
- ② Dimensions, 1.2mm (L) x 1.0mm (W)
- ③ Number of lines, 2P= 2 lines
- ④ Common Mode Impedance (at 100MHz), 900= 90Ω
- ⑤ Tolerance of common mode impedance, M= ±25%
- ⑥ Type of electrode plating: F= Lead Free
- ⑦ Packing Type, R= Reel

4. 2 Specification of electrical characteristics

Characteristics	Common Mode Impedance	Resistance	Leakage Current	Capacitance	Insulation Resistance (Max)	Rated Voltage	Rated Current
symbol	Z_{CM}	R_{DC}	I_L	C	IR_{CR}	V_R	I_R
Units	Ω	Ω	μA	pF	M Ω	Volt	mA
Test Condition	@100MHz	25°C ±2°C	5V	0.5Vrms @1MHz	10V	25°C ±2°C	25°C ±2°C
Value	90(±25%)	Max 4.0	Max 1.0	Max 1.7	Min 10	5	Max100

■ TERMINOLOGY

- V_t : Per IEC 61000-4-2, 30A@8kV, level 4, trigger voltage measured initiation of pulse, all test in contact discharge mode.
- V_c : Per IEC 61000-4-2, 30A@8kV, level 4, clamp measurement made 30ns after initiation of pulse, all test in contact discharge mode.

- Impedance Curves

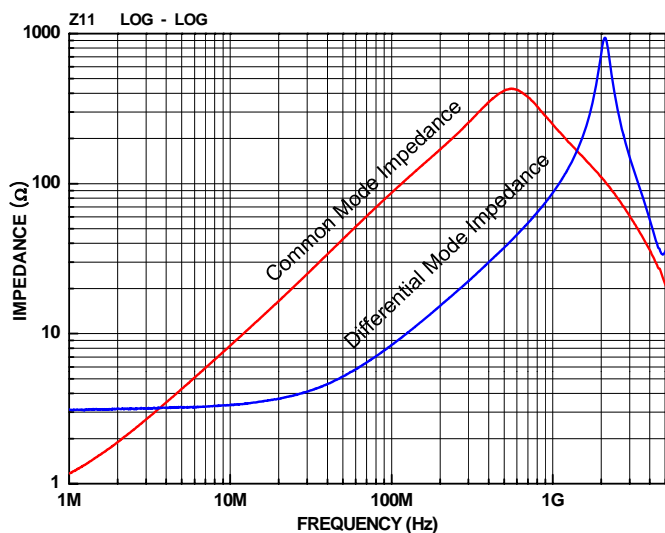

-Transmission characteristics (S-parameter)

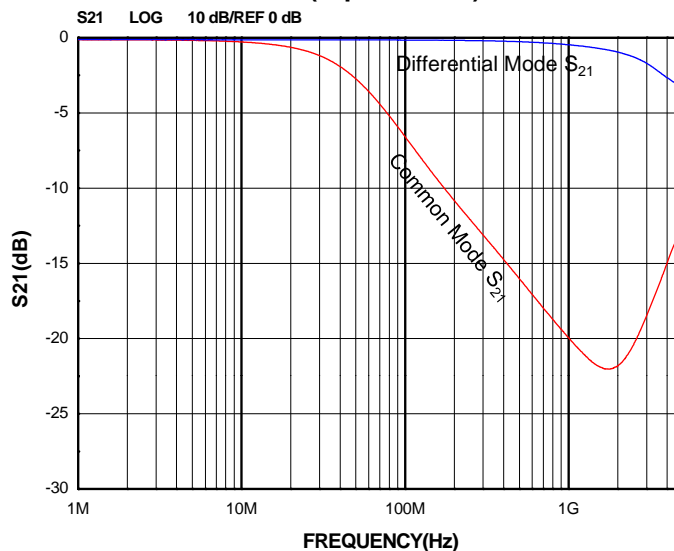

4. 3 Operating Temperature

DESCRIPTION	REQUIREMENTS
Operating Temperature	-40°C ~ + 85°C

5. Equivalent Circuit

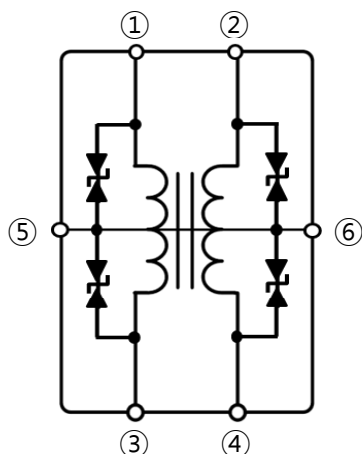

PIN NUMBER	DESCRIPTION
①~④	DATA LINE
⑤, ⑥	GROUND

6. Mechanical Property

6. 1 Appearance and Dimension

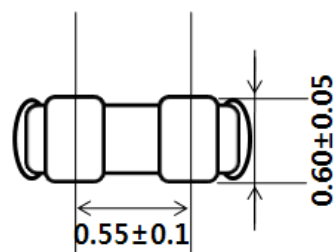
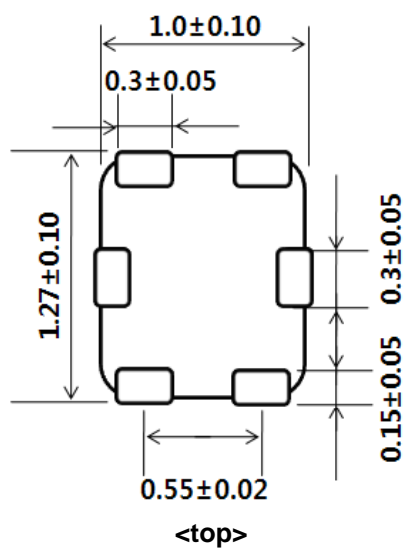

Unit : mm