

Dimension Tables

CMM 100/200 SERIES in male & female styles for LF contacts

CMM SERIES 100 & 200 Male	LF contacts number series 100	2	3	4	5	6	7	8	9	10	11	12	13	14	15	16	17	18	19	20	21	22	23	24	25	
	LF contacts number series 200	4	6	8	10	12	14	16	18	20	22	24	26	28	30	32	34	36	38	40	42	44	46	48	50	
	Length in mm	A	2	4	6	8	10	12	14	16	18	20	22	24	26	28	30	32	34	36	38	40	42	44	46	48
	Length in mm (Strap)	B	6,7	8,7	10,7	12,7	14,7	16,7	18,7	20,7	22,7	24,7	26,7	28,7	30,7	32,7	34,7	36,7	38,7	40,7	42,7	44,7	46,7	48,7	50,7	52,7
	Length in mm	C	7,4	9,4	11,4	13,4	15,4	17,4	19,4	21,4	23,4	25,4	27,4	29,4	31,4	33,4	35,4	37,4	39,4	41,4	43,4	45,4	47,4	49,4	51,4	53,4
Length C with Latches fitted			7,8	9,8	11,8	13,8	15,8	17,8	19,8	21,8	23,8	25,8	27,8	29,8	31,8	33,8	35,8	37,8	39,8	41,8	43,8	45,8	47,8	49,8	51,8	53,8

CMM SERIES 100 & 200 Female	LF contacts number series 100	2	3	4	5	6	7	8	9	10	11	12	13	14	15	16	17	18	19	20	21	22	23	24	25	
	LF contacts number series 200	4	6	8	10	12	14	16	18	20	22	24	26	28	30	32	34	36	38	40	42	44	46	48	50	
	Length in mm	A	2	4	6	8	10	12	14	16	18	20	22	24	26	28	30	32	34	36	38	40	42	44	46	48
	Length in mm	B	7	9	11	13	15	17	19	21	23	25	27	29	31	33	35	37	39	41	43	45	47	49	51	53

LF CONTACTS REFERENCE MARK NUMBER FOR CMM SERIES 200 Male & Female	D	1	1	1	1	1	1	1	1	1	1	1	1	1	1	1	1	1	1	1	1	1	1	1	1
	E	2	3	4	5	6	7	8	9	10	11	12	13	14	15	16	17	18	19	20	21	22	23	24	25
	F	3	4	5	6	7	8	9	10	11	12	13	14	15	16	17	18	19	20	21	22	23	24	25	26
	G	4	6	8	10	12	14	16	18	20	22	24	26	28	30	32	34	36	38	40	42	44	46	48	50

CMM 220 SERIES in male & female styles for LF contacts

CMM SERIES 220 Male & Female	LF contacts number	4	6	8	10	12	14	16	18	20	22	24	26	28	30	32	34	36	38	40	42	44	46	48	50	52	54	56	58	60	
	Distance between axis	A	2	4	6	8	10	12	14	16	18	20	22	24	26	28	30	32	34	36	38	40	42	44	46	48	50	52	54	56	58
		B	9	11	13	15	17	19	21	23	25	27	29	31	33	35	37	39	41	43	45	47	49	51	53	55	57	59	61	63	65
	Length in mm	C	14	16	18	20	22	24	26	28	30	32	34	36	38	40	42	44	46	48	50	52	54	56	58	60	62	64	66	68	70
	LF contacts reference mark number	D	1	1	1	1	1	1	1	1	1	1	1	1	1	1	1	1	1	1	1	1	1	1	1	1	1	1	1	1	
		E	2	3	4	5	6	7	8	9	10	11	12	13	14	15	16	17	18	19	20	21	22	23	24	25	26	27	28	29	30
F		3	4	5	6	7	8	9	10	11	12	13	14	15	16	17	18	19	20	21	22	23	24	25	26	27	28	29	30	31	
G		4	6	8	10	12	14	16	18	20	22	24	26	28	30	32	34	36	38	40	42	44	46	48	50	52	54	56	58	60	

CMM 220 SERIES in male & female styles for HF/HP contacts

CMM 220 Male & Female Special contacts only	Special contacts number	2	3	4	5	6	7	8	9	10	11	12	13	14	15	
	Distance between axis	A	4	8	12	16	20	24	28	32	36	40	44	48	52	56
		B	13	17	21	25	29	33	37	41	45	49	53	57	61	65
Length in mm	C	18	22	26	30	34	38	42	46	50	54	58	62	66	70	

CMM 320 SERIES in male & female styles for LF contacts

CMM SERIES 320 Male & Female	LF contacts number	6	9	12	15	18	21	24	27	30	33	36	39	42	45	48	51	54	57	60	63	66	69	72	75	78	81	84	87	90	93	96	99	102	105	108	111	114	117	120		
	Distance between axis	A	2	4	6	8	10	12	14	16	18	20	22	24	26	28	30	32	34	36	38	40	42	44	46	48	50	52	54	56	58	60	62	64	66	68	70	72	74	76	78	
		B	11	13	15	17	19	21	23	25	27	29	31	33	35	37	39	41	43	45	47	49	51	53	55	57	59	61	63	65	67	69	71	73	75	77	79	81	83	85	87	
	Length in mm	C	17	19	21	23	25	27	29	31	33	35	37	39	41	43	45	47	49	51	53	55	57	59	61	63	65	67	69	71	73	75	77	79	81	83	85	87	89	91	93	
	LF contacts reference mark number	D	1	1	1	1	1	1	1	1	1	1	1	1	1	1	1	1	1	1	1	1	1	1	1	1	1	1	1	1	1	1	1	1	1	1	1	1	1	1	1	1
		E	2	3	4	5	6	7	8	9	10	11	12	13	14	15	16	17	18	19	20	21	22	23	24	25	26	27	28	29	30	31	32	33	34	35	36	37	38	39	40	
		F	3	4	5	6	7	8	9	10	11	12	13	14	15	16	17	18	19	20	21	22	23	24	25	26	27	28	29	30	31	32	33	34	35	36	37	38	39	40	41	
		G	4	6	8	10	12	14	16	18	20	22	24	26	28	30	32	34	36	38	40	42	44	46	48	50	52	54	56	58	60	62	64	66	68	70	72	74	76	78	80	
H		5	7	9	11	13	15	17	19	21	23	25	27	29	31	33	35	37	39	41	43	45	47	49	51	53	55	57	59	61	63	65	67	69	71	73	75	77	79	81		
J	6	9	12	15	18	21	24	27	30	33	36	39	42	45	48	51	54	57	60	63	66	69	72	75	78	81	84	87	90	93	96	99	102	105	108	111	114	117	120			

CMM 340 SERIES in male & female styles for HF/HP contacts

CMM 340 Male & Female Special contacts only	Special contacts number	4	6	8	10	12	14	16	18	20	22	24	26	28	30	32	34	36	38	40	42	44	46	48	50	52	54	56	58	60	62	64	
	Distance between axis	A	2,5	5	7,5	10	12,5	15	17,5	20	22,5	25	27,5	30	32,5	35	37,5	40	42,5	45	47,5	50	52,5	55	57,5	60	62,5	65	67,5	70	72,5	75	77,5
		B	12,5	15	17,5	20	22,5	25	27,5	30	32,5	35	37,5	40	42,5	45	47,5	50	52,5	55	57,5	60	62,5	65	67,5	70	72,5	75	77,5	80	82,5	85	87,5
Length in mm	C	18,5	21	23,5	26	28,5	31	33,5	36	38,5	41	43,5	46	48,5	51	53,5	56	58,5	61	63,5	66	68,5	71	73,5	76	78,5	81	83,5	86	88,5	91	93,5	

CMM Specifications (with LF contacts)

MATERIALS

INSULATOR: Special PPS (Polyphenylene Sulfide Fiberglass filled thermoplastic) UL 94-V0

- Radiation resistance
- No humidity absorption
- Oxygen free

Note : PPS characteristics are recognized for space applications

P.C. LF CONTACTS :

Male:

Tail : copper alloy / Ni + Au flash 0,1 μ
Contact area : copper alloy / Ni + Au > 1 μ

Female:

Body : copper alloy / Ni + Au 0,2 μ
Socket : beryllium copper / Ni + Au > 1,25 μ

CRIMP LF CONTACTS :

Male:

Body : copper alloy / Ni + Au > 1 μ

Female:

Body : copper alloy / Ni + Au > 0,2 μ
Socket : beryllium copper / Ni + Au > 1,25 μ

FIXING HARDWARE:

- Jackscrew: Stainless steel.
- Latch : Beryllium copper/plated nickel (CMM 100/200 series only)

ELECTRICAL

- All contacts 3 A max. @ 25°C
2.2 A max. @ 85°C
- Working voltage (sea level) Tested at 800 V DC
- Proof voltage Tested at 1 200 V DC
- Contact resistance (initially) max. 10 m Ω
- Insulation resistance 1 000 M Ω min.

MECHANICAL

- Mechanical operations Up to 2500 cycles
- Contact insertion and withdrawal force 2 N max. / 0.2 N min. per contact
- Contact retention in insulator 10 N min.
- Contact replacement in insulator 3 cycles (Crimp contacts only)

ENVIRONMENTAL

- Temperature range From - 60°C to + 260°C
Reflow solder process compatible (+260°C)
- Vibration severity 0.75 mm, 10 g RMS 6 hours long random with superimposed sinusoid. No intermittencies measured when using an H.S.L.I (High Speed Logic Interrupt) detector with a trip threshold of 2 ns.
MIL-DTL-55302F Test Condition III [147.1 m/s² (15 gn) peak]
- Shock severity 100 g for 6 ms
- Solvent resistance HcFc 141 bMGX (ATOCHEM) solvent

Note :

The CMM micro-connectors are designed to meet or exceed the relevant electrical and environmental performances described in MIL-DTL-55302F & BS-9525-F0033 standards.

HF / HP contacts specifications

MATERIALS

• Spring loaded parts	Be/Cu gold plated
• Other metal parts	Copper alloy
• Insulator	PTFE (HF)
• Retaining clip	Be/Cu Ni plated

MECHANICAL

• Mechanical operations	Up to 2500 cycles
• Insertion force	From 0.60 to 5 N per contact
• Withdrawal force	From 0.50 to 2 N per contact
• Secure overlapping	1.30 mm
• Contact replacement in insulator	50 cycles for HF / HP 30 series (5 cycles for HF / HP 22 series)

ELECTRICAL

High Power (HP) Contact		High Frequency (HF) Contact	
Intensity	Series 30 : 20 A Series 22 : 10 A } depending on cable	Impedance	50Ω / 75Ω
Contact resistance	max. 6 mΩ	Insulation resistance	10 ⁶ MΩ / 250 V (RMS)
Maximum voltage (sea level)	1000 V (RMS)	SWR (Stationary wave rate)	< 1.05 + 0.04 F (GHz)
Operating voltage (sea level)	180 V AC/500 mA	Frequency range	Series 30 : 6 GHz Series 22 : 1,5 GHz } depending on cable
		Insulation between 2 contacts	-100 dB (depending on cable)

ENVIRONMENTAL

• Temperature range	From -60°C to +260°C
• Salt spray test	96 hrs
• Humidity test	56 days @ 90% humidity

HF / HP CONTACTS PART NUMBERING

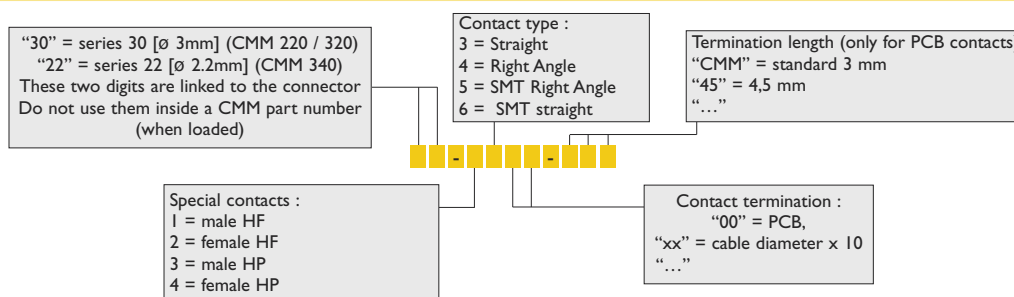

Important notice:

According to the routines test other than MIL our technical features for CMM Micro-connectors reach a higher result. Please contact technic@nicomatic.fr for more information.

For example:

- LF: up to 5A max. @ 25°C
- HF: up to 11 GHz
- HP: up to 30 A
- Mechanical operations: up to 5 000 cycles
- High temperature test: 1 000H at 250°C
- Application with LVDS signal @ 400 MHz, impedance 100 Ohm
- High speed: USB, 1Gb/s Ethernet...

HIGHLIGHT ON CMM CONNECTOR BENEFITS

- **Unlimited style of connector:**
 - Mixed-layout: High, Low frequency & High power in 1 connector
 - PCB solder, SMT, press fit, crimp contacts
 - Board to board, board to wire, wire to wire connections
 - Very small footprint: 2 mm pitch (saves up to 60% space & 50% weight over conventional connectors)
- Meets or exceeds the relevant electrical & environmental performances described in MIL-DTL-55302F & BS-9525-F0033 standards
- Excellent mechanical & environmental characteristics
- Built-in jackscrews for high vibrations
- Resistance to solvents, radiations & oxygen free
- Allows infrared, wave or vapour phase soldering
- High reliability contact design: up to 2 500 cycles
- RoHS & Whiskers free (all contacts are gold plated)
- Short lead time: 1 week delivery service
- 100% quality control
- Proven track record in defense, aerospace & railway as well as other high reliability or technology field applications
- Connector housing marking for full traceability
- Large range of accessories & tools

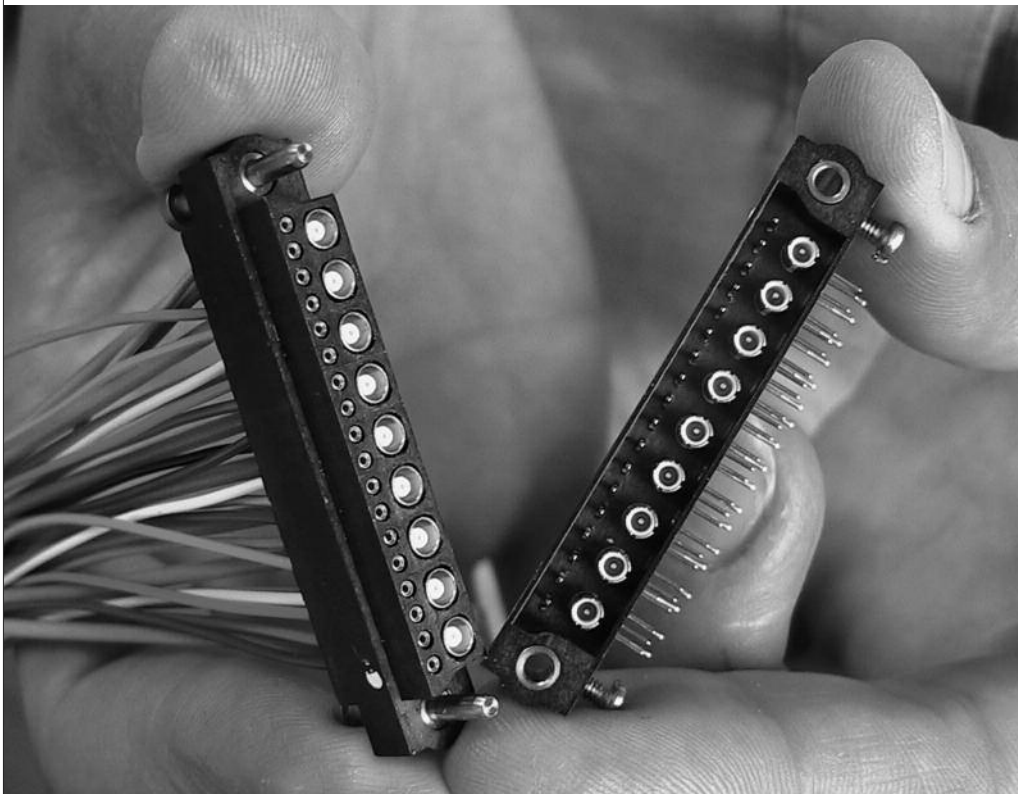

LF : low frequency contacts

PRESENTATION

Male						
Female						
	Straight PCB Type Y	90° PCB Type V	Straight SMT Type T	90° SMT Type R	Crimp Type S - C	Straight PCB Type PF Press fit

INFORMATION TABLE

CMM RANGE		USE												
		STRAIGHT ON PCB				90° ON PCB		STRAIGHT SMT		90° SMT	CRIMP			
100/200	Male	Y L=3,0	YL L=4,5	YM L=5,1	YX L=9,1			V L=3,0	VL L=4,5	T L=2,25	TL L=3,35	R L=0,9	C Gauge 22	S Gauge 24-28
	Female	Y L=3,0	YL L=4,5			YC L=1,2	PF Press fit	V L=3,0	VL L=4,5	T L=2,25	TL L=3,35	R L=0,9	C Gauge 22	S Gauge 24-28
220	Male	Y L=3,0	YL L=4,5	YM L=5,1	YX L=9,1			V L=3,0	VL L=4,5	T L=2,25	TL L=3,35	R L=0,9	C Gauge 22	S Gauge 24-28
	Female	Y L=3,0	YL L=4,5			YC L=1,2	PF Press fit	V L=3,0	VL L=4,5	T L=2,25	TL L=3,35	R L=0,9	C Gauge 22	S Gauge 24-28
320	Male	Y L=3,0	YL L=4,5	YM L=5,1	YX L=9,1			V L=3,0	VL L=4,5			R L=0,9	C Gauge 22	S Gauge 24-28
	Female	Y L=3,0	YL L=4,5				PF Press fit	V L=3,0	VL L=4,5				C Gauge 22	S Gauge 24-28
340	Male	Y L=3,0	YL L=4,5	YM L=5,1	YX L=9,1			V L=3,0	VL L=4,5				C Gauge 22	S Gauge 24-28
	Female	Y L=3,0	YL L=4,5				PF Press fit	V L=3,0	VL L=4,5				C Gauge 22	S Gauge 24-28

L=6,50 / 8,00 / 10,50 / 12,00 / 14,50 / 16,00 mm upon request (only for straight on PCB male contacts)

Standard contact

Any other type of contact upon request only

Straight on PCB

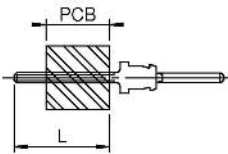

90° on PCB

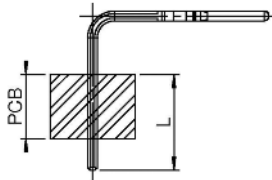

SMT straight on PCB

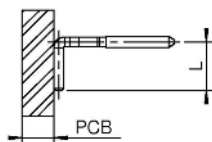

SMT 90° on PCB

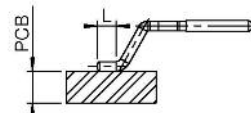

Pressfit
Straight on PCB

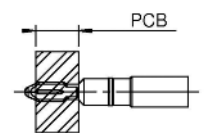

Ref : 12960
Male crimp contact "C"
for AWG 22

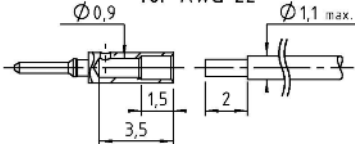

Ref : 12969
Male crimp contact "S"
for AWG 24-28

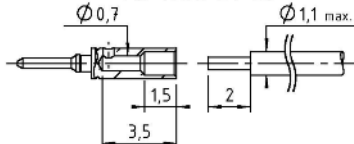

Ref : C13064-P
Female crimp contact "C"
for AWG 22 cable

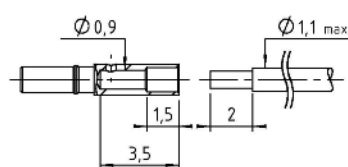

Ref : C12468
Female crimp contact "S"
for AWG 24-28

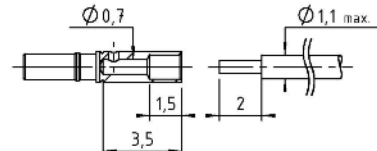

HF : high frequency contacts (series 30)

PRESENTATION

Male								
	Female							
		Straight PCB	90° PCB	Straight SMT	90° SMT Card edge	Straight Crimp	90° Crimp	Straight solder
Type D					Type E			

INFORMATION TABLE

CMM RANGE	TYPICAL USE											
	TYPE OF CONTACTS TO BE USED IN THE CMM CONNECTOR WITH CAVITIES FOR HF/HP CONTACTS ONLY											
	TYPE D FOR SPECIAL CONTACTS ON PCB (Eg.221D00F22-00 nbr of special contact-1300CMM)						TYPE E FOR SPECIAL CONTACTS ON CABLE					
	Straight on PCB		90° on PCB		Straight SMT	90° SMT Card edge	Straight Crimp	90° Crimp	Straight solder	90° solder		
100/200	Male											
	Female											
220	Male	30-1300-CMM L=3,0	30-1300-45 L=4,5	30-1400-CMM L=3,0	30-1400-45 L=4,5	30-1600	30-1500-CMM no LF contact	30-1500-12	30-13XX-SS 30-13XX-DS xx=cable type	30-14XX-ZS 30-14XX-DS xx=cable type	30-13XX-ZZ xx=cable type	30-14XX-ZZ xx=cable type
	Female	30-2300-CMM L=3,0	30-2300-45 L=4,5	30-2400-CMM L=3,0	30-2400-45 L=4,5	30-2600			30-23XX-SS 30-23XX-DS xx=cable type	30-24XX-ZS 30-24XX-DS xx=cable type	30-23XX-ZZ xx=cable type	30-24XX-ZZ xx=cable type
320	Male	30-1300-CMM L=3,0	30-1300-45 L=4,5	30-1400-CMM L=3,0	30-1400-45 L=4,5			30-1500-12	30-13XX-SS 30-13XX-DS xx=cable type	30-14XX-ZS 30-14XX-DS xx=cable type	30-13XX-ZZ xx=cable type	30-14XX-ZZ xx=cable type
	Female	30-2300-12 L=3,0	30-2300-14 L=4,5	30-2400-CMM L=3,0	30-2400-45 L=4,5				30-23XX-SS 30-23XX-DS xx=cable type	30-24XX-ZS 30-24XX-DS xx=cable type	30-23XX-ZZ xx=cable type	30-24XX-ZZ xx=cable type
340	Male											
	Female											

Standard contact
Any other type of contact upon request only

XX = 12, 20, 24, 26
Eg. 24 = cable Ø 2,4
XX = 20 or 26 for DS cable

XX = 47, 85
Eg. 47 for UT47 cable

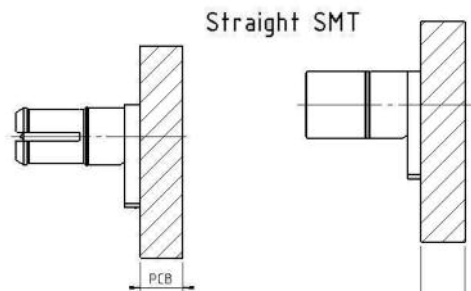
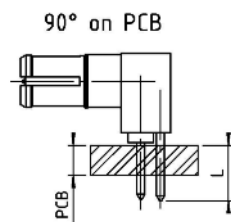
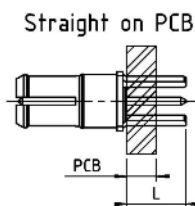
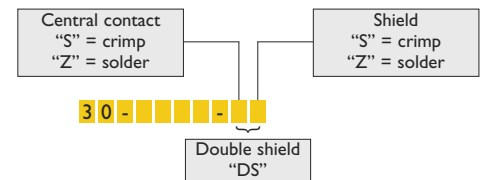

HP : high power contacts (series 30)

PRESENTATION

Male									
Female									
	Straight PCB	90° PCB	Straight SMT	90° SMT	90° SMT Card edge	Straight Crimp	90° Crimp	Straight solder	90° solder
	Type D					Type E			

INFORMATION TABLE

CMM RANGE		TYPICAL USE									
		TYPE OF CONTACTS TO BE USED IN THE CMM CONNECTOR WITH CAVITIES FOR HF/HP CONTACTS ONLY									
		TYPE D FOR SPECIAL CONTACTS ON PCB					TYPE E FOR SPECIAL CONTACTS ON CABLE				
		Straight on PCB	90° on PCB	Straight SMT	90° SMT	90° SMT Card edge	Straight Crimp	90° Crimp	Straight solder	90° solder	
100/200	Male										
	Female										
220	Male	30-3300-CMM L=3,0	30-3300-45 L=4,5	30-3400-CMM L=3,0	30-3400-45 L=4,5	30-3600	30-3500	30-3500-CMM no LF contact	30-3500-12	30-33XX	30-33XX
	Female	30-4300-CMM L=3,0	30-4300-45 L=4,5	30-4400-CMM L=3,0	30-4400-45 L=4,5	30-4600	30-4500			30-43XX	30-43XX
320	Male	30-3300-CMM L=3,0	30-3300-45 L=4,5	30-3400-CMM L=3,0	30-3400-45 L=4,5				30-3500-12	30-33XX	30-33XX
	Female	30-4300-12 L=3,0	30-4300-14 L=4,5	30-4400-CMM L=3,0	30-4400-45 L=4,5					30-43XX	30-43XX
340	Male										
	Female										

Standard contact
Any other type of contact upon request only

XX = 05, 08...
Eg. 08 for 8A

Please refer
to page 94

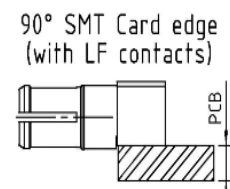
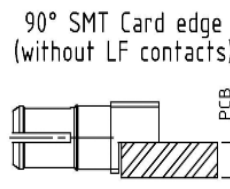
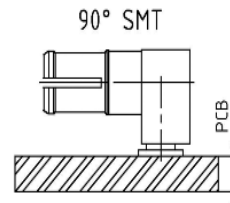
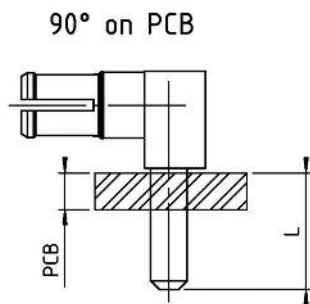
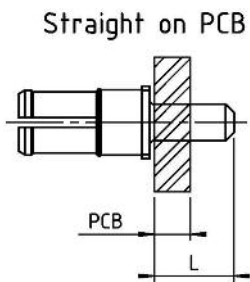

HF : high frequency contacts (series 22)

PRESENTATION

Male								
	Straight PCB	90° PCB	Straight SMT	90° SMT	Straight Crimp	90° Crimp	Straight solder	90° solder
	Type D				Type E			

INFORMATION TABLE

CMM RANGE		TYPICAL USE							
		TYPE OF CONTACTS TO BE USED IN THE CMM CONNECTOR WITH CAVITIES FOR HF/HP CONTACTS ONLY							
		TYPE D FOR SPECIAL CONTACTS ON PCB				TYPE E FOR SPECIAL CONTACTS ON CABLE			
		Straight on PCB	90° on PCB	Straight SMT	90° SMT	Straight Crimp	90° Crimp	Straight solder	90° solder
100/200	Male								
	Female								
220	Male								
	Female								
320	Male								
	Female								
340	Male	22-1300-12 L=3,0	22-1300-14 L=4,5	22-1400-12* 22-1400-22** L=3,0	22-1400-14* 22-1400-24** L=4,5		22-1312-ZS		22-1320-ZZ
	Female	22-2300-12 L=3,0	22-2300-14 L=4,5	22-2400-12* 22-2400-22** L=3,0	22-2400-14* 22-2400-24** L=4,5		22-2312-ZS		22-2320-ZZ

Standard contact
Any other type of contact upon request only

12 = cable Ø 1,2

20 = cable Ø 2,0

* First row : 22-1400-12 / 22-1400-14 / 22-2400-12 / 22-2400-14
** Second row : 22-1400-22 / 22-1400-24 / 22-2400-22 / 22-2400-24

Straight on PCB

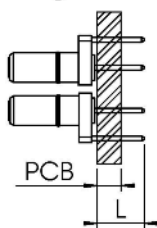

90° on PCB

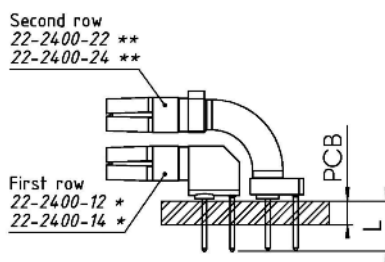

90° on PCB

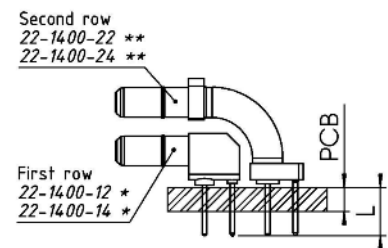

When a two-row connector mixes a 22-2400-12 and a 22-2400-22 contact, the P/N of the HF contact changes to 2400-02.

When a two-row connector mixes a 22-2400-14 and a 22-2400-24 contact, the P/N of the HF contact changes to 2400-04.

When a two-row connector mixes a 22-1400-12 and a 22-1400-22 contact, the P/N of the HF contact changes to 1400-02.

When a two-row connector mixes a 22-1400-14 and a 22-1400-24 contact, the P/N of the HF contact changes to 1400-04.

HP : high power contacts (series 22)

PRESENTATION

Male								
Female								
	Straight PCB	90° PCB	Straight SMT	90° SMT	Straight Crimp	90° Crimp	Straight solder	90° solder
	Type D				Type E			

INFORMATION TABLE

CMM RANGE		TYPICAL USE							
		TYPE OF CONTACTS TO BE USED IN THE CMM CONNECTOR WITH CAVITIES FOR HF/HP CONTACTS ONLY							
		TYPE D FOR SPECIAL CONTACTS ON PCB				TYPE E FOR SPECIAL CONTACTS ON CABLE			
		Straight on PCB	90° on PCB	Straight SMT	90° SMT	Straight Crimp	90° Crimp	Straight solder	90° solder
100/200	Male								
	Female								
220	Male								
	Female								
320	Male								
	Female								
340	Male	22-3300-12 L=3,0	22-3300-14 L=4,5	22-3400-12* 22-3400-22** L=3,0	22-3400-14* 22-3400-24** L=4,5			22-33XX	22-33XX
	Female	22-4300-12 L=3,0	22-4300-14 L=4,5	22-4400-12* 22-4400-22** L=3,0	22-4400-14* 22-4400-24** L=4,5			22-43XX	22-43XX

Standard contact

Any other type of contact upon request only

XX = 05, 08, 10
10 = 10A

Please refer
to page 102

* First row : 22-3400-12 / 22-3400-14 / 22-4400-12 / 22-4400-14

** Second row : 22-3400-22 / 22-3400-24 / 22-4400-22 / 22-4400-24

Straight on PCB

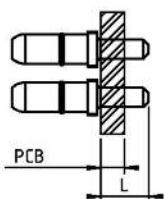

90° on PCB

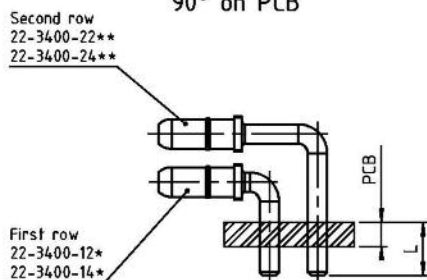

When a two-row connector mixes a 22-3400-12 and a 22-3400-22 contact, the P/N of the HF contact changes to 3400-02.

When a two-row connector mixes a 22-3400-14 and a 22-3400-24 contact, the P/N of the HF contact changes to 3400-04.

90° on PCB

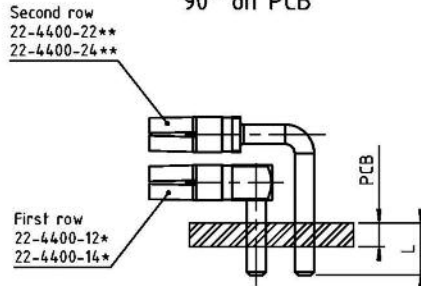

When a two-row connector mixes a 22-4400-12 and a 22-4400-22 contact, the P/N of the HF contact changes to 4400-02.

When a two-row connector mixes a 22-4400-14 and a 22-4400-24 contact, the P/N of the HF contact changes to 4400-04.

Male housing marking

CMM 100/200

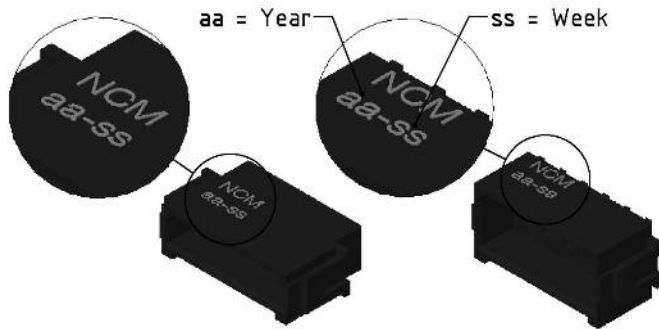

Marking : NCM (Nicomatic) + date code (Lot number)

CMM 220

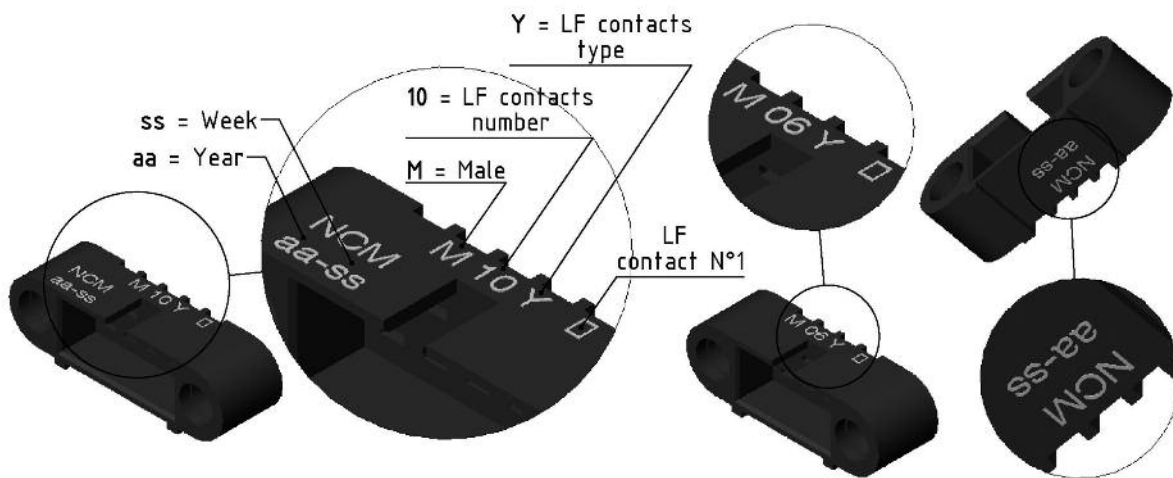

Marking 1 : NCM (Nicomatic) + date code (Lot number)
(LF contacts only) Connector P/N
LF contact number I

Marking on two faces if the number of LF contacts is < to 10.

Marking 2 : NCM (Nicomatic) + date code (Lot number) : CMM 220 mixed layout (LF + HF/HP)
(as for CMM 100/200)

CMM 220 with HF/HP contacts
CMM 220 with 04 LF contacts

Marking LF contacts type : Y-YL-V-VL-R-T-S-C

CMM 320/340

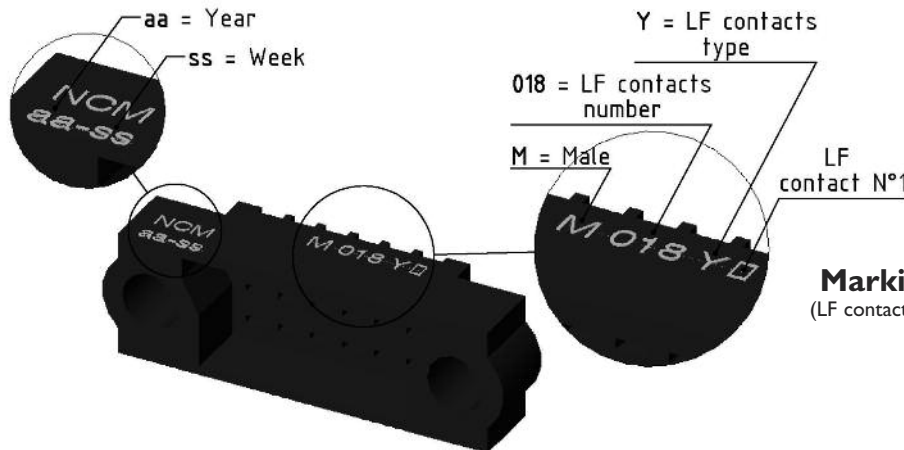

Marking 1 : NCM (Nicomatic)
(LF contacts only) / date code (Lot number)
Connector P/N
LF contact number I

Marking 2 : NCM (Nicomatic) / date code (Lot number) : CMM 320 mixed layout
(as for CMM 100/200)

CMM 320 with HF/HP contacts
CMM 340

Marking LF contacts type : Y-YL-V-VL-S-C

Female housing marking

CMM 100/200

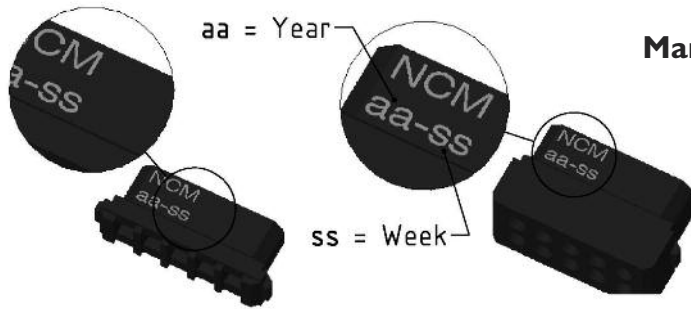

Marking : NCM (Nicomatic) + date code (Lot number)

CMM 220

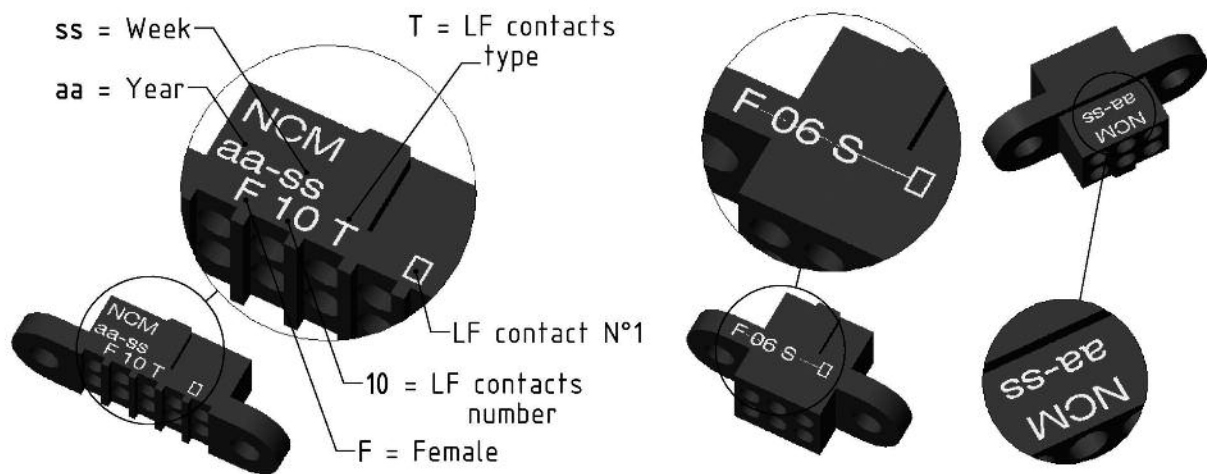

Marking 1 : NCM (Nicomatic) + date code (Lot number)
(LF contacts only) Connector P/N
LF contact number I

Marking on two faces if the number of LF contacts is < to 10.

Marking 2 : NCM (Nicomatic) + date code (Lot number) : CMM 220 mixed layout (LF + HF/HP)
(as for CMM 100/200)

CMM 220 with HF/HP contacts
CMM 220 with 04 LF contacts

Marking LF contacts type : Y-YL-V-VL-R-T-S-C-PF

CMM 320/340

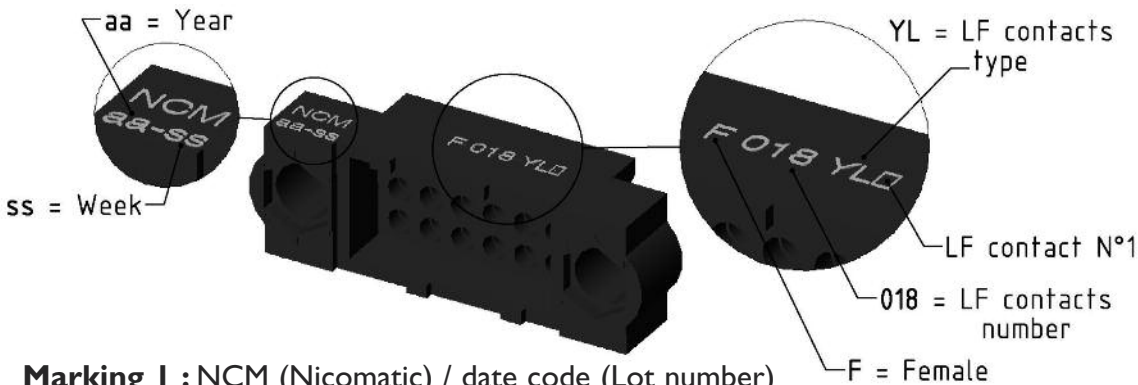

Marking 1 : NCM (Nicomatic) / date code (Lot number)
(LF contacts only) Connector P/N
LF contact number I

Marking 2 : NCM (Nicomatic) / date code (Lot number) : CMM 320 mixed layout HF/HP contacts
(as for CMM 100/200)

CMM 320 with HF/HP contacts
CMM 340

Marking LF contacts type : Y-YL-V-VL-S-C-PF

numbering system

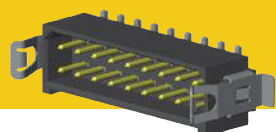
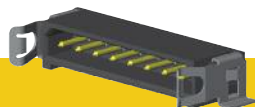
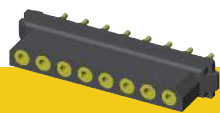

CMM 100/200 Series

p. 17 to 25

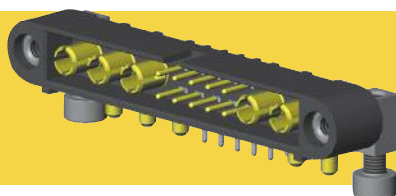
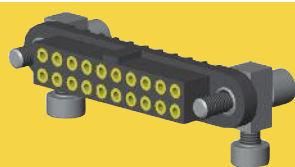

CMM 220 Series

p. 27 to 46

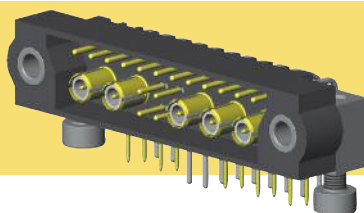
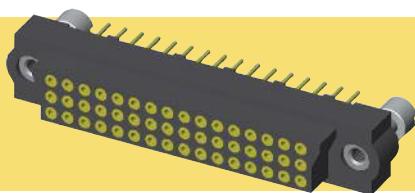

CMM 320 Series

p. 47 to 59

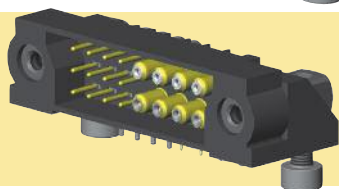
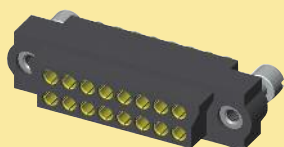

CMM 340 Series

p. 60 to 74

High Frequency and High Power contacts (HF) (HP)

p. 75 to 102

Tools and accessories

p. 103 to 112

Cable instructions & assembly

p. 113 to 122

CMM 220 with LF contacts

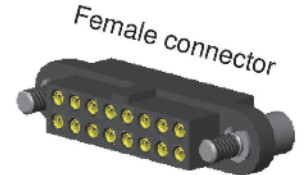
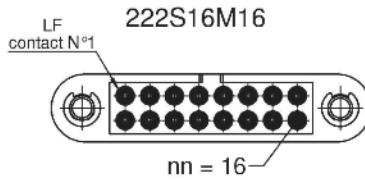
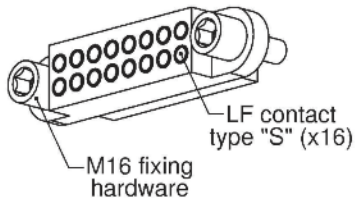
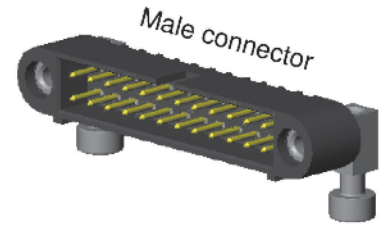
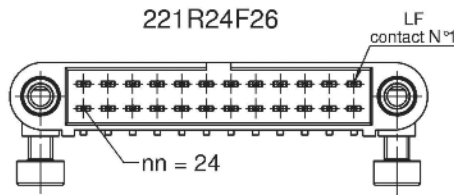
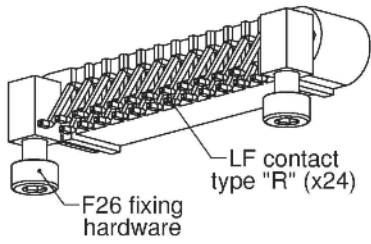

PART NUMBERING REMINDER

Code with Low Frequency contacts only				
Series	Gender	Termination Style	Number of LF contacts	Fixing Hardware
■	■	■	n n	■
2 rows	22	1 male	Refer to table on page 7	04 to 60
		2 female		

CMM 220 Configuration

CONNECTOR SPACING

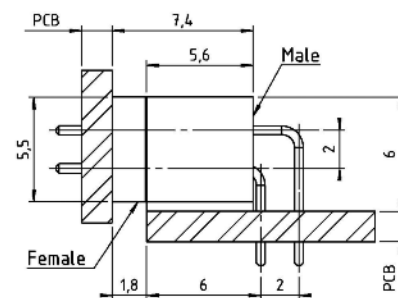
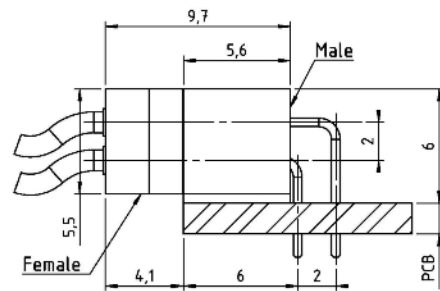
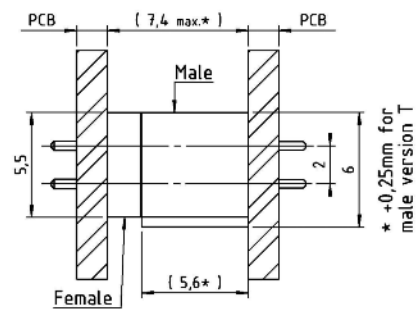
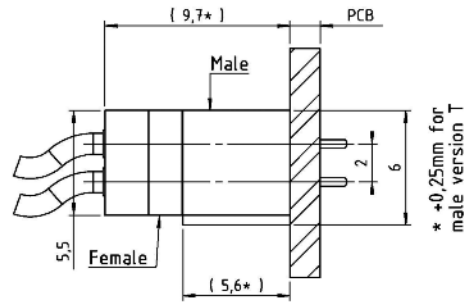
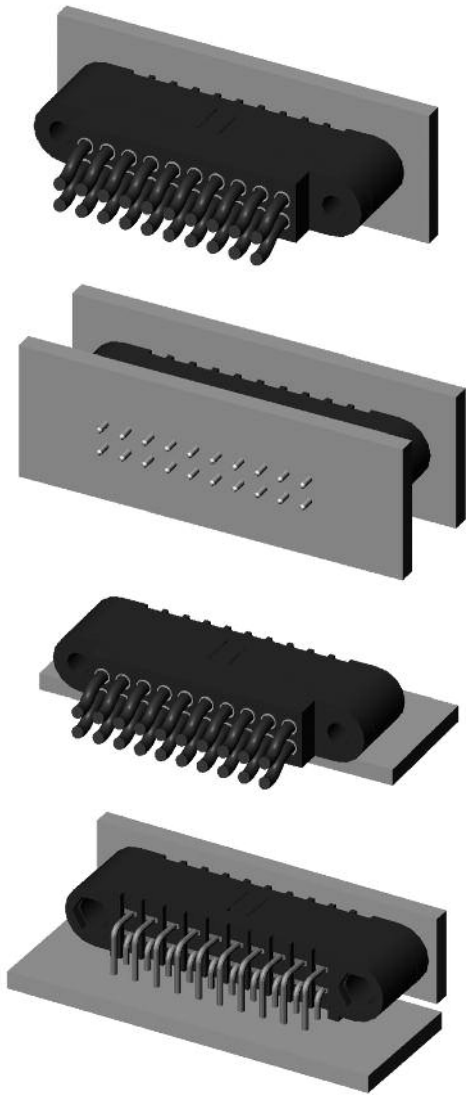

CONTACTS POSITIONS



Female connectors
(shown looking onto mating face)

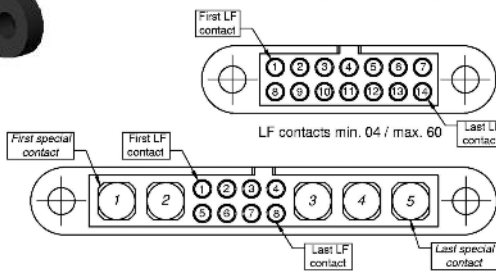

Mixed layout max. configuration depends on the total LF contacts number

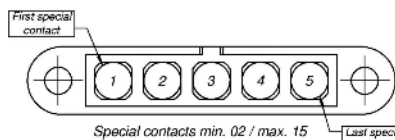

Special contacts min. 02 / max. 15



Male connectors
(shown looking onto mating face)

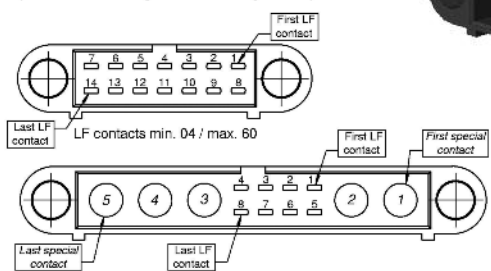

Mixed layout max. configuration depends on the total LF contacts number

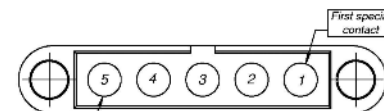

Special contacts min. 02 / max. 15

CMM 220 male

STRAIGHT PCB

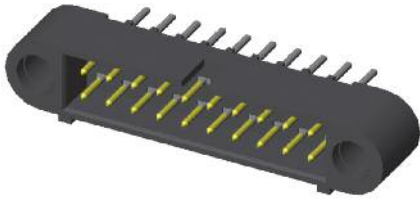

nn min = 04 nn max = 60

Part numbering :

Type :Y-YL

2 2 | n n

See Fixing on page 43, 44
"Fxx" without fixing

nn = number of LF contacts

Type	L
Y	3
YL	4,5

Calculation :

$$A = nn - 2$$

$$B = A + 7$$

$$C = A + 12$$

Refer to dimension table on cover page

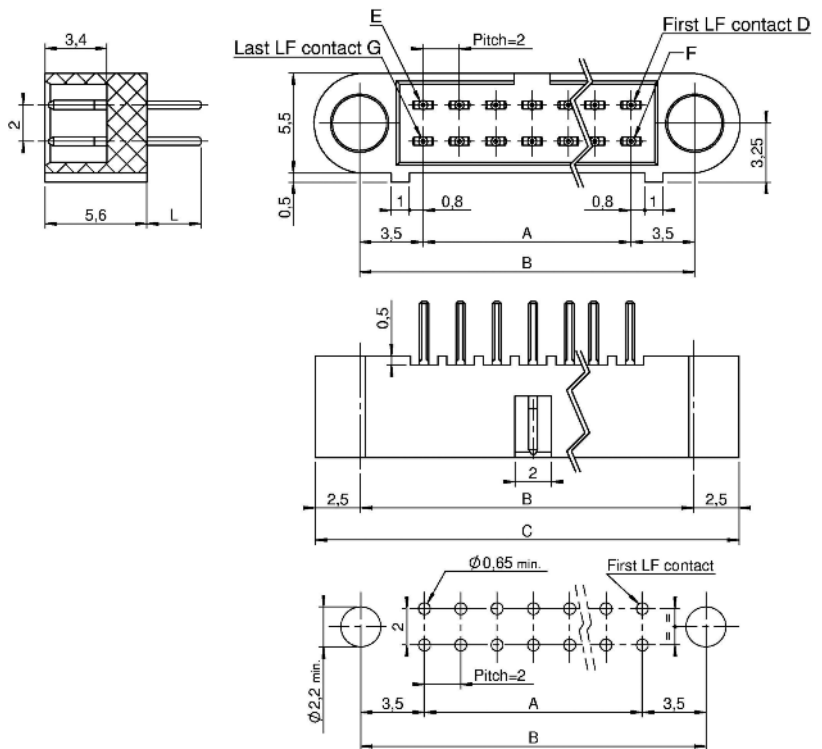

90° PCB

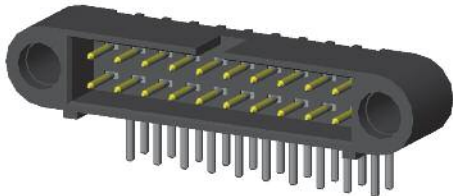

nn min = 04 nn max = 60

Part numbering :

Type :V-VL

2 2 | n n

See Fixing on page 43, 44
"Fxx" without fixing

nn = number of LF contacts

Type	L
V	3
VL	4,5

Calculation :

$$A = nn - 2$$

$$B = A + 7$$

$$C = A + 12$$

Refer to dimension table on cover page

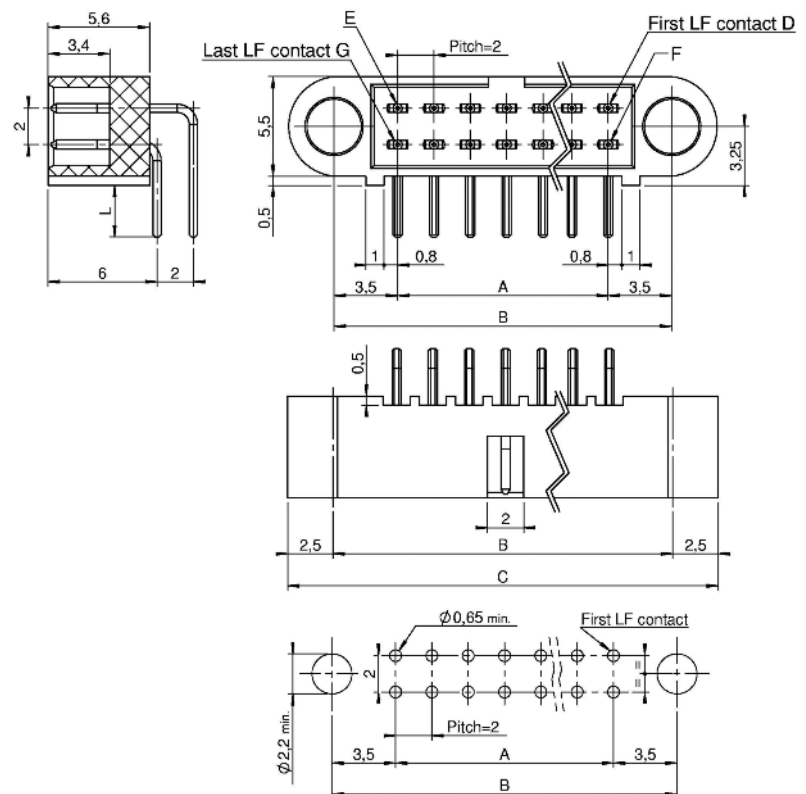

CMM 220 male

STRAIGHT SMT

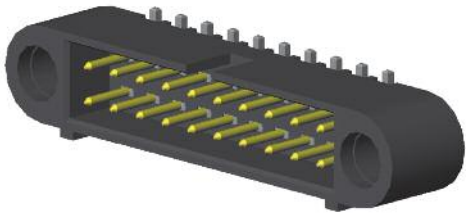

nn min = 04 nn max = 60

Part numbering :

Type : T-TL

2 2 | 1 | n n

See Fixing on page 43, 44
"Fxx" without fixing

nn = number of LF contacts

Optional: Packaging in reel available upon request

Calculation :

A	= nn - 2
----------	----------

B	= A + 7
----------	---------

C	= A + 12
----------	----------

Refer to dimension table on cover page

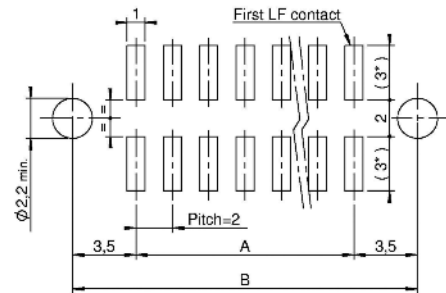
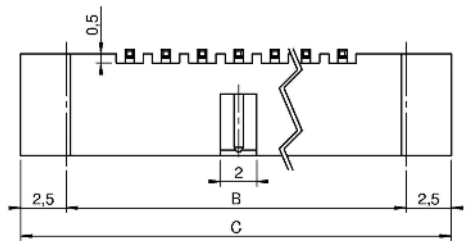
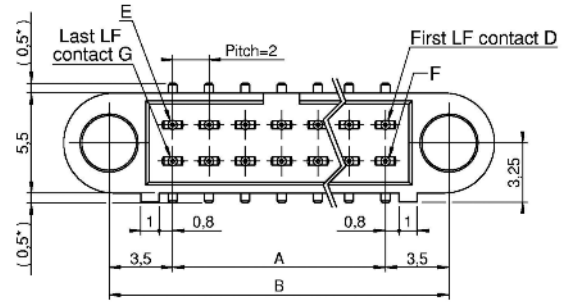
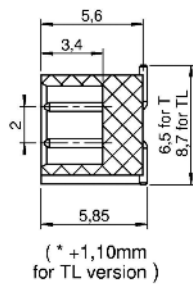

90° SMT

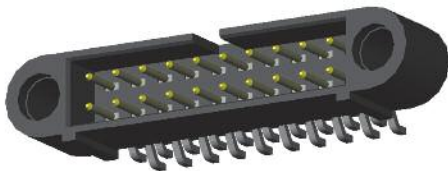

nn min = 04 nn max = 60

Part numbering :

2 2 | 1 R | n n

See Fixing on page 43, 44
"Fxx" without fixing

nn = number of LF contacts

Optional: Packaging in reel available upon request

Calculation :

A	= nn - 2
----------	----------

B	= A + 7
----------	---------

C	= A + 12
----------	----------

Refer to dimension table on cover page

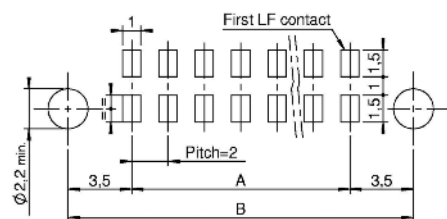
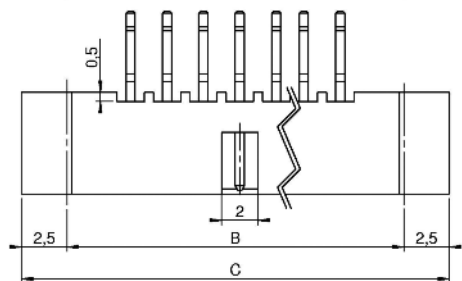
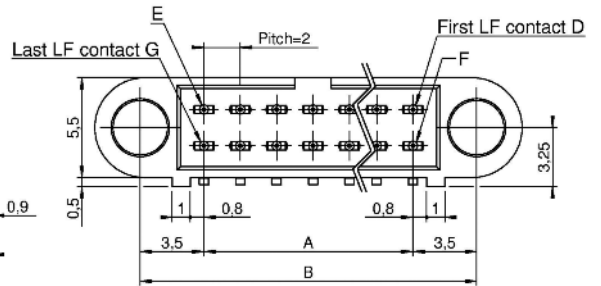
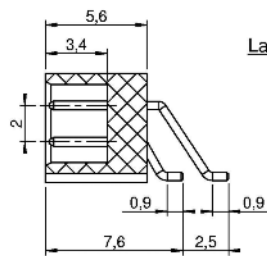

CMM 220 male

CRIMP

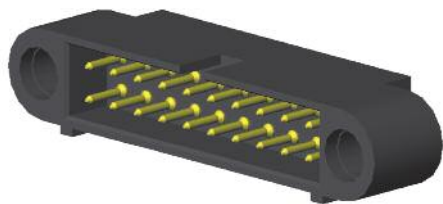

nn min = 04 nn max = 60

Part numbering :

Type : S-C

2 2 | l | n n

See Fixing on page 43, 44
"Fxx" without fixing

nn = number of LF contacts

Type	Gauge
S	24-28
C	22

Calculation :

A = nn - 2
B = A + 7
C = A + 12

Refer to dimension table on cover page

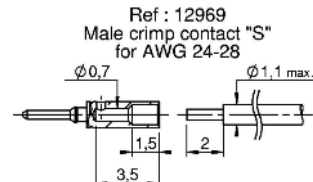
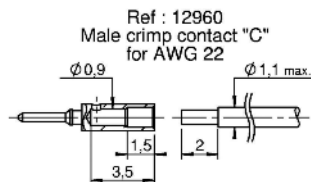
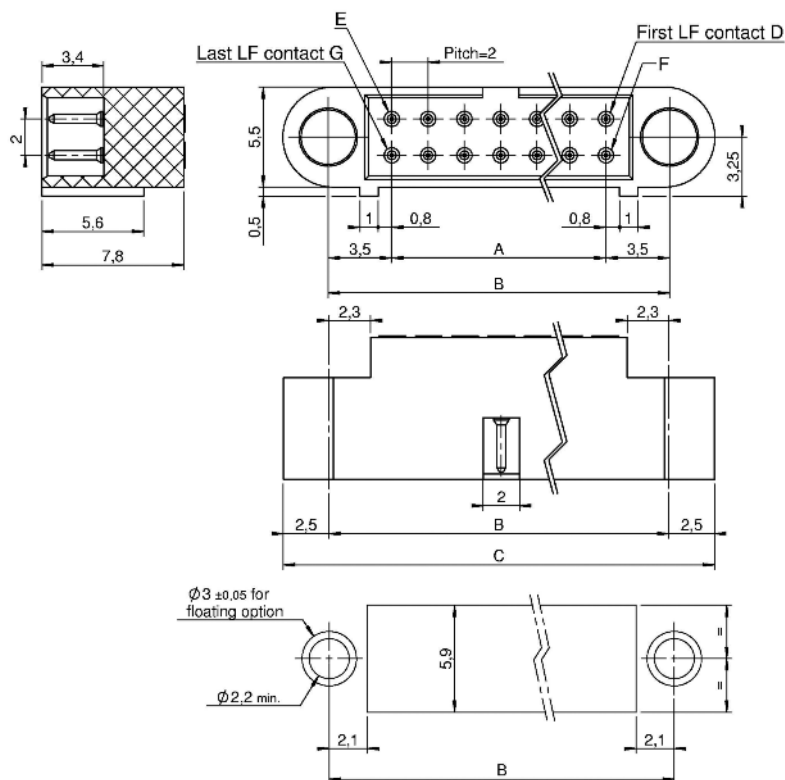

CMM 220 female

STRAIGHT PCB

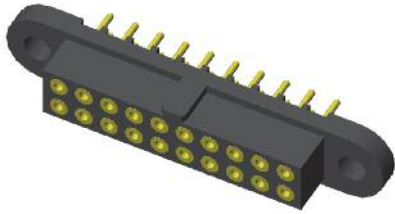

nn min = 04 nn max = 60

Part numbering :

Type :Y-YL

2 2 2 n n

See Fixing on page 45-46
"Mxx" without fixing

nn = number of LF contacts

Type	L
Y	3
YL	4,5

Calculation :

$$A = nn - 2$$

$$B = A + 7$$

$$C = A + 12$$

Refer to dimension table on cover page

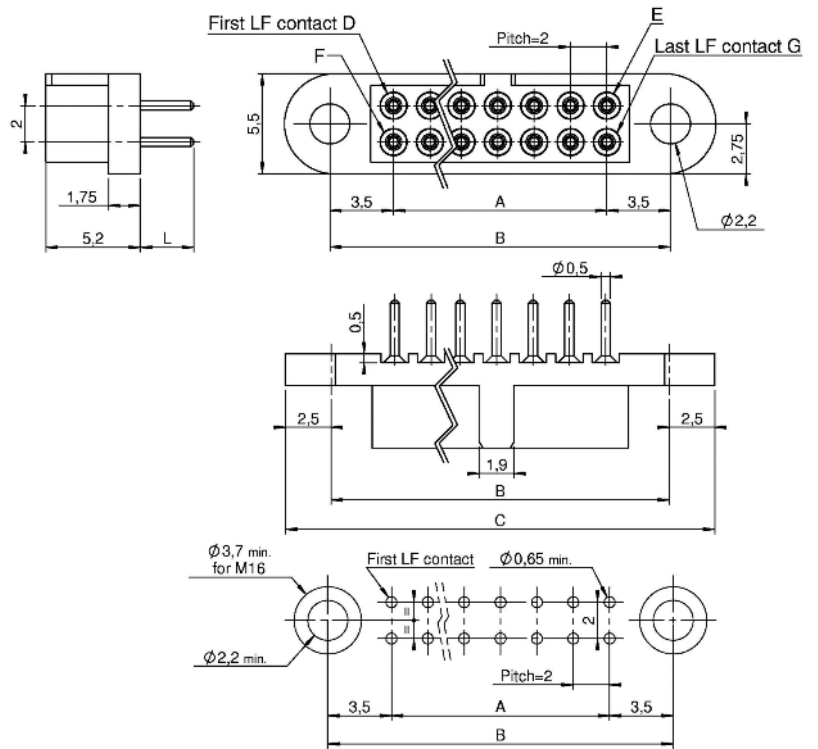

90° PCB

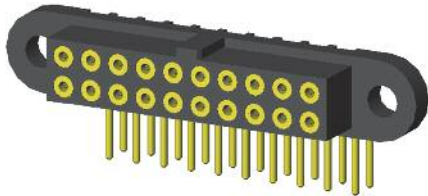

nn min = 04 nn max = 60

Part numbering :

Type :V-VL

2 2 2 n n

See Fixing on page 45
"Mxx" without fixing

nn = number of LF contacts

Type	L
V	3
VL	4,5

Calculation :

$$A = nn - 2$$

$$B = A + 7$$

$$C = A + 12$$

Refer to dimension table on cover page

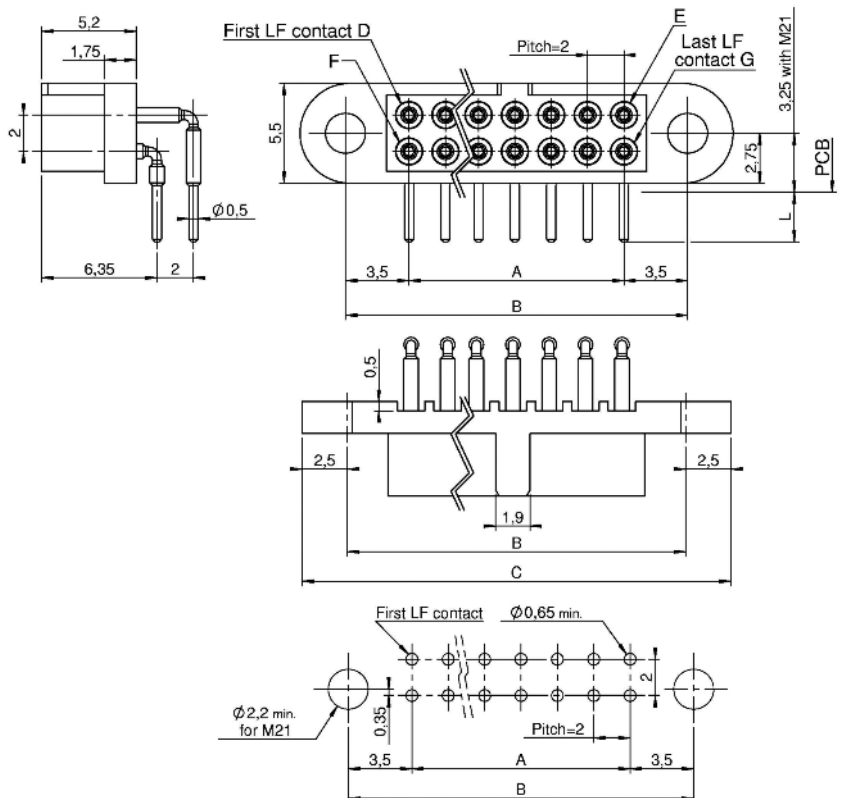

CMM 220 female

STRAIGHT SMT

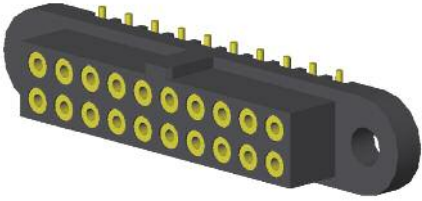

nn min = 04 nn max = 60

Part numbering :

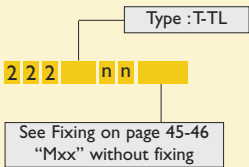

nn = number of LF contacts

Optional: Packaging in reel available upon request

Calculation :

A = nn - 2
B = A + 7
C = A + 12

Refer to dimension table on cover page

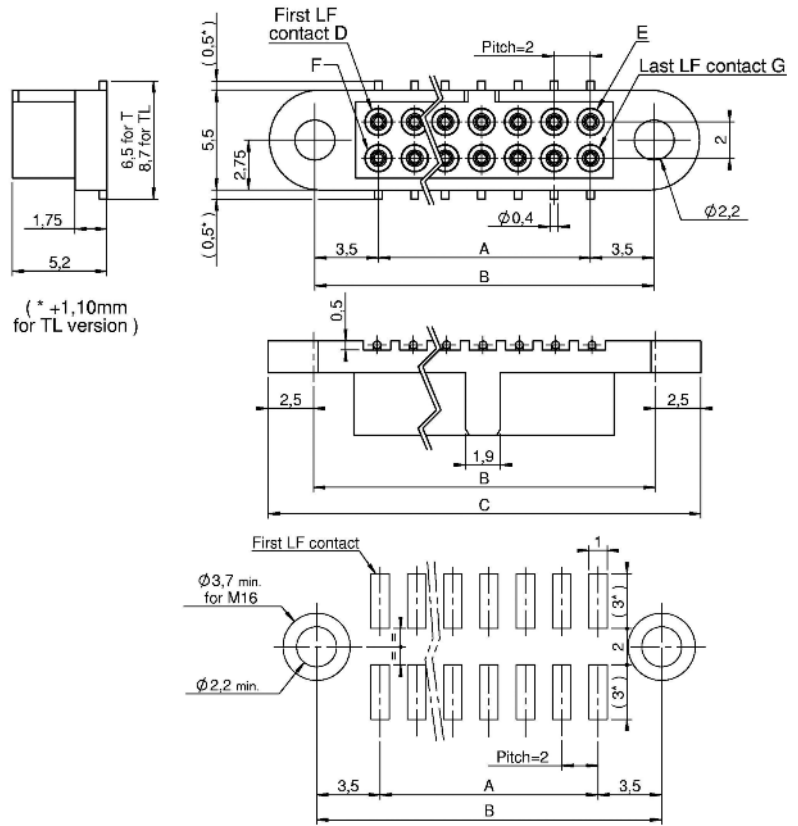

90° SMT

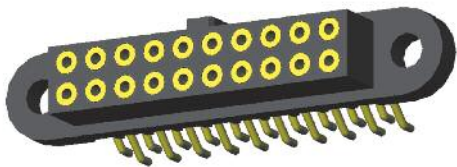

nn min = 04 nn max = 60

Part numbering :

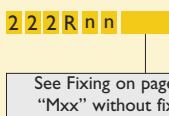

nn = number of LF contacts

Optional: Packaging in reel available upon request

Calculation :

A = nn - 2
B = A + 7
C = A + 12

Refer to dimension table on cover page

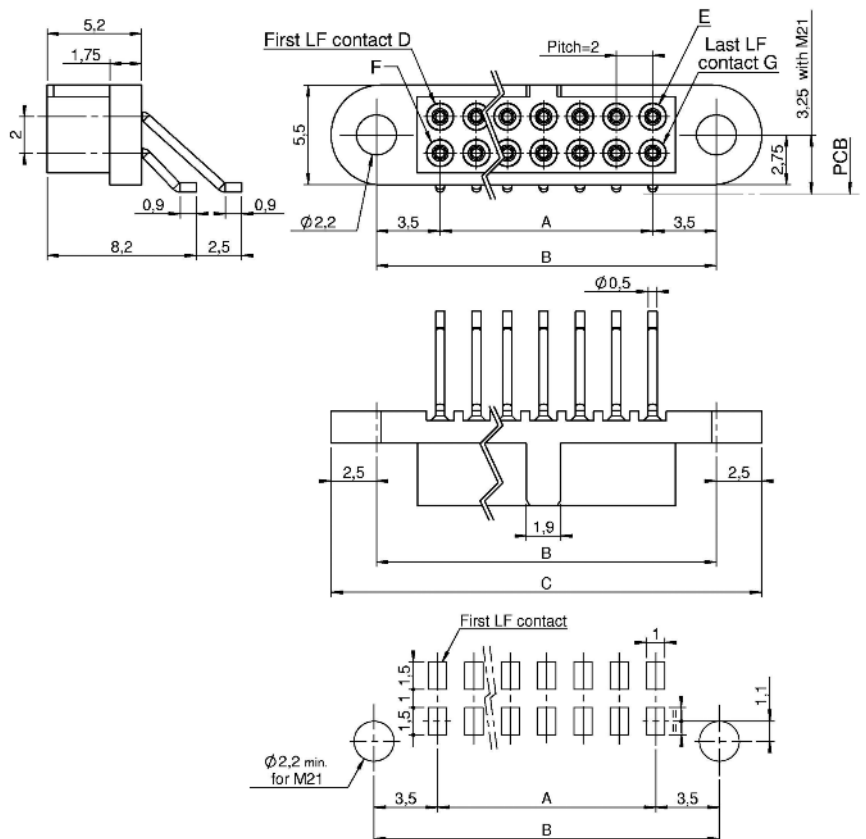

CMM 220 female

STRAIGHT PRESS FIT

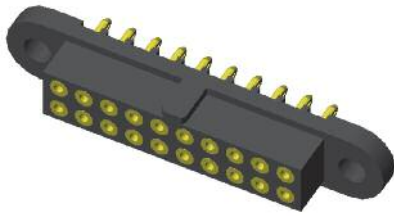

nn min = 04 nn max = 60

Part numbering :

2 2 2 PF n n

See Fixing on page 45-46
"Mxx" without fixing

nn = number of LF contacts

Calculation :

A = nn - 2
B = A + 7
C = A + 12

Refer to dimension table on cover page

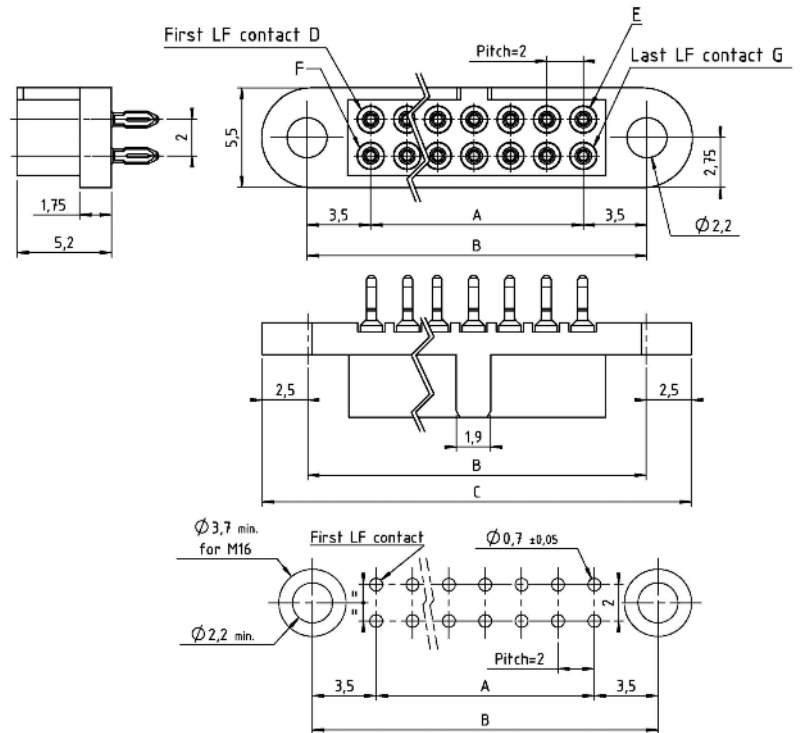

CRIMP



nn min = 04 nn max = 60

Part numbering :

Type : S-C

2 2 2 n n

See Fixing on page 45-46
"Mxx" without fixing

nn = number of LF contacts

Type	Gauge
S	24-28
C	22

Calculation :

A = nn - 2
B = A + 7
C = A + 12

Refer to dimension table on cover page

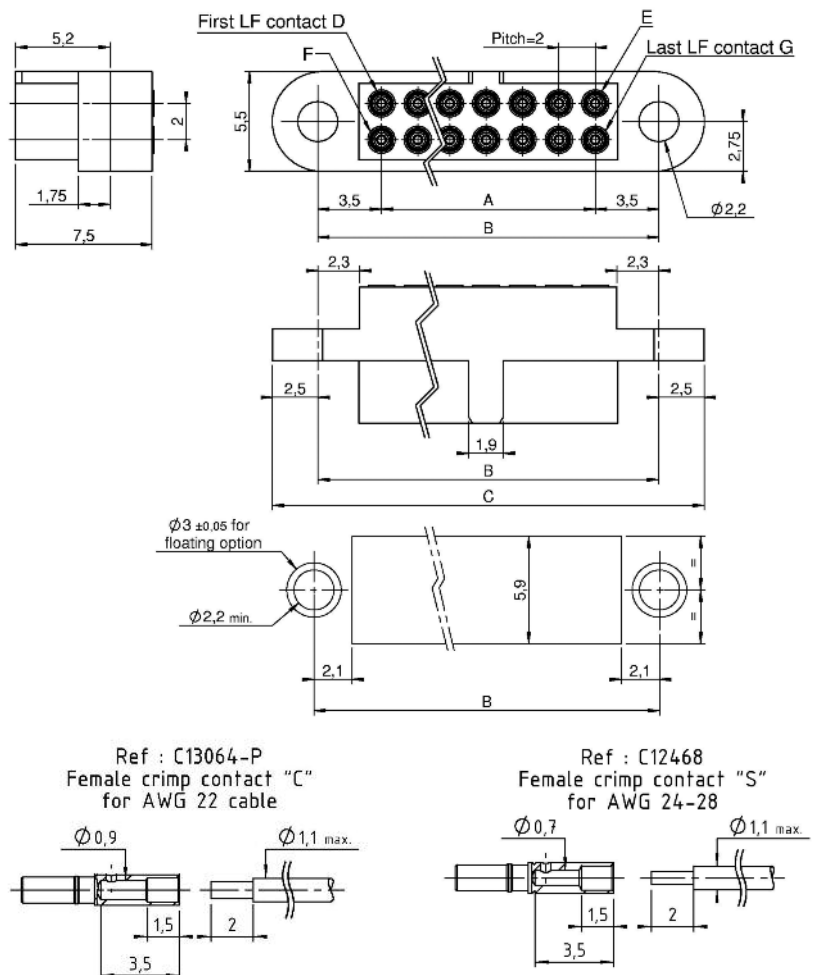

CMM 220 mixed-layout

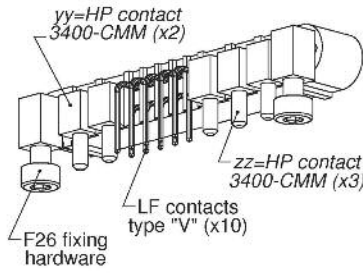

221V10F26-0203-3400CMM

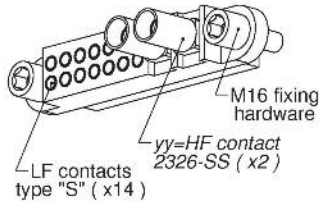
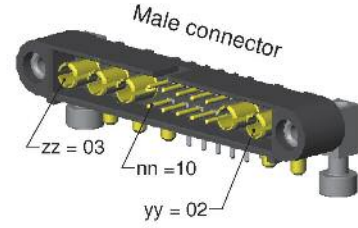
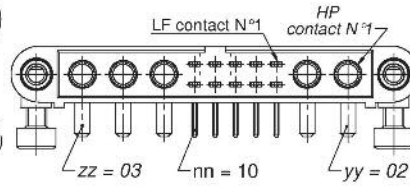

222S14M16-0200-2326SS

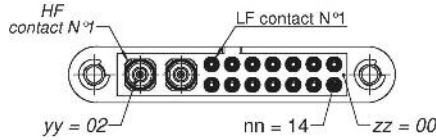

(HF contacts are supplied -not fitted- under P/N 30-2326-SS)

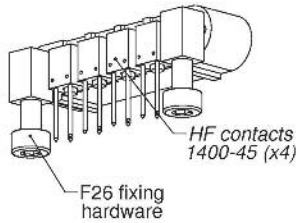
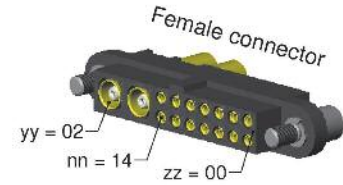

221D00F26-0004-140045

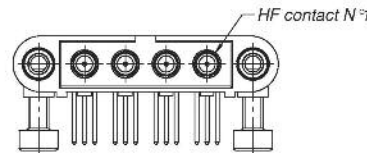

"D" stated in P/N for connectors on PCB with only special contacts.

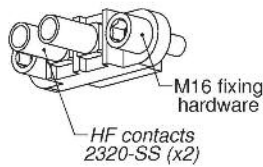
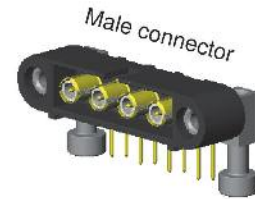

222E00M16-0002-2320SS

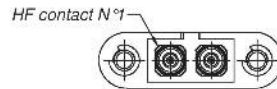

(HF contacts are supplied -not fitted- under P/N 30-2320-SS)

"E" stated in P/N for connectors on cable with only special contacts.

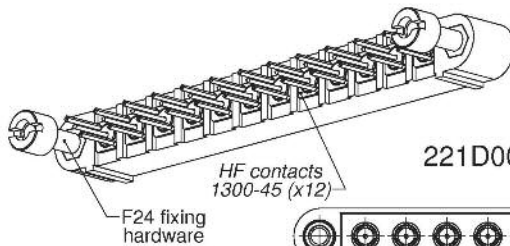

221D00F24-0012-130045

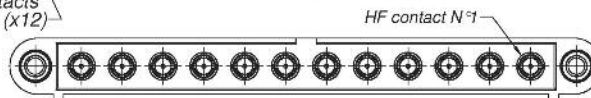

"D" stated in P/N for connectors on PCB with only special contacts.

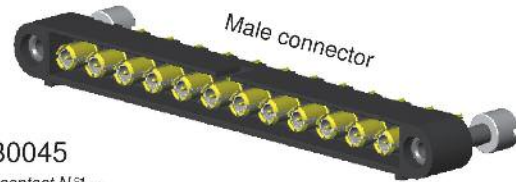

PART NUMBERING REMINDER

Code with Low Frequency contacts only					Additional code for mixed-layout connector (HF/HP)		
Series	Gender	Termination Style	Number of LF contacts	Fixing Hardware	Number of HF/HP contacts pin I side (LF contact number I)	Number of HF/HP contacts opposite to LF contact number I	HF/HP Contact Type
■ ■	■	■	n n	■ -	y y	z z - ■ ■ ■ ■ ■ ■ ■ ■	
2 rows	22	1 male	Refer to table on page 7	04 to 60	Refer to pages 43 to 46	Depends upon the number of LF contacts If use with shifted central key, please refer to page 42 HF / HP : 15 contacts max. Type of HF/HP contact : please refer to pages 8-9	HP/HP 30 please refer to pages 75 to 94
		2 female					

CMM 220

Male mixed-layout

STRAIGHT PCB

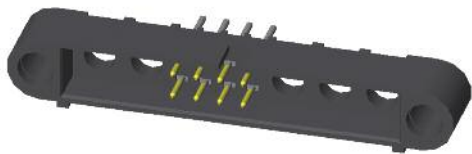

Part numbering :

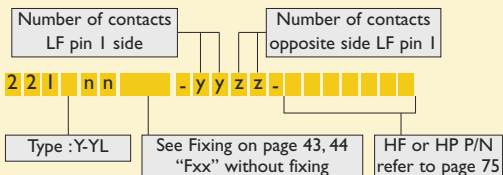

nn = number of LF contacts

Type	L
Y	3
YL	4,5

Pattern for special contact :

HF 30-1300-xx PCB lay-out

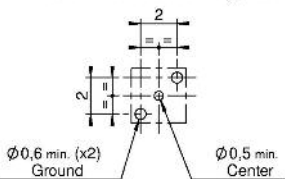

HP 30-3300-xx PCB lay-out

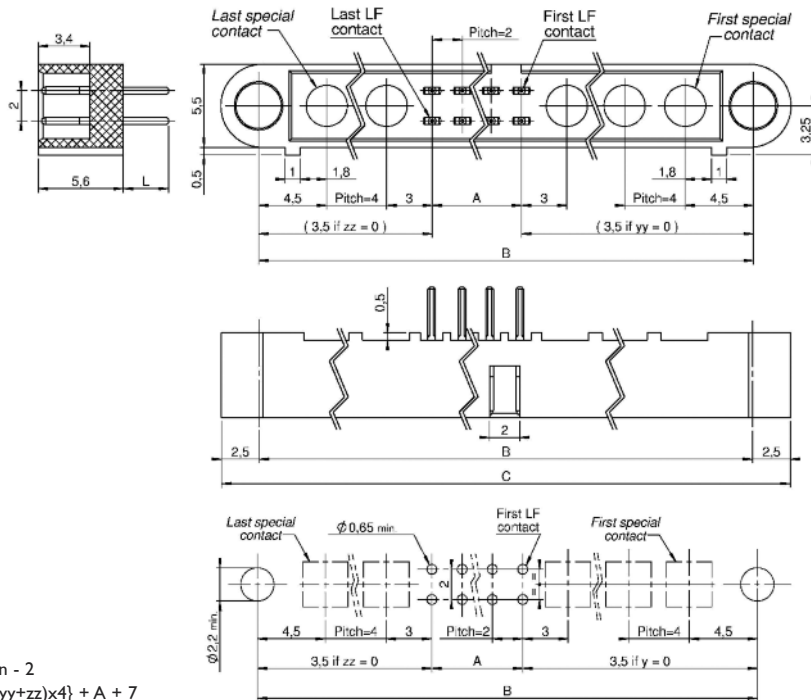
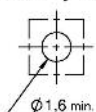

$A = nn - 2$
 $B = \{(yy+zz) \times 4\} + A + 7$
 $B_{max.} = 65 \text{ mm}$
 $C = B + 5$

STRAIGHT PCB FOR HP/HF CONTACTS ONLY



Part numbering :

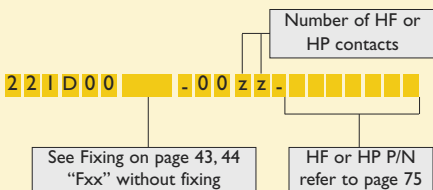

Pattern for special contact :

HF 30-1300-xx PCB lay-out

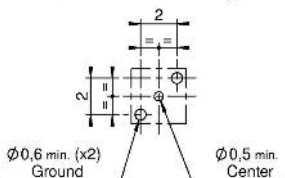

HP 30-3300-xx PCB lay-out

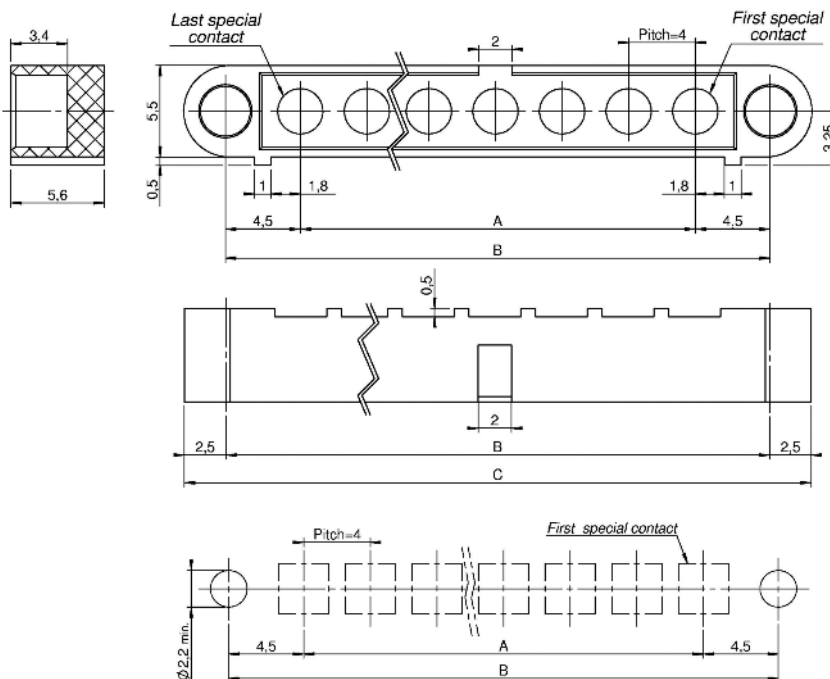
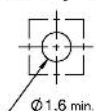

$A = (zz \times 4) - 4$
 $B = A + 9$
 $C = B + 5$

Special contacts min. : 02
max. : 15

Refer to dimension table on cover page

CMM 220

Male mixed-layout

90° PCB

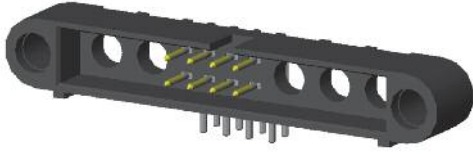

Part numbering :

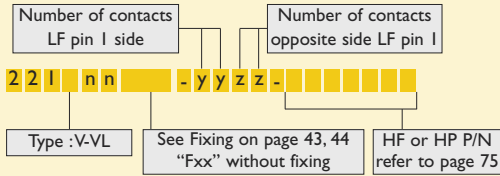

nn = number of LF contacts

Type	L
V	3
VL	4,5

Pattern for special contact :

HF 30-1400-xx PCB lay-out

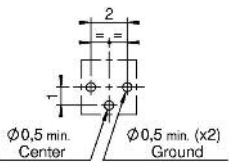

HP 30-3400-xx PCB lay-out

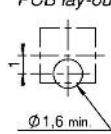

$$A = nn - 2$$

$$B = \{(yy+zz) \times 4\} + A + 7$$

$$B_{max.} = 65 \text{ mm}$$

$$C = B + 5$$

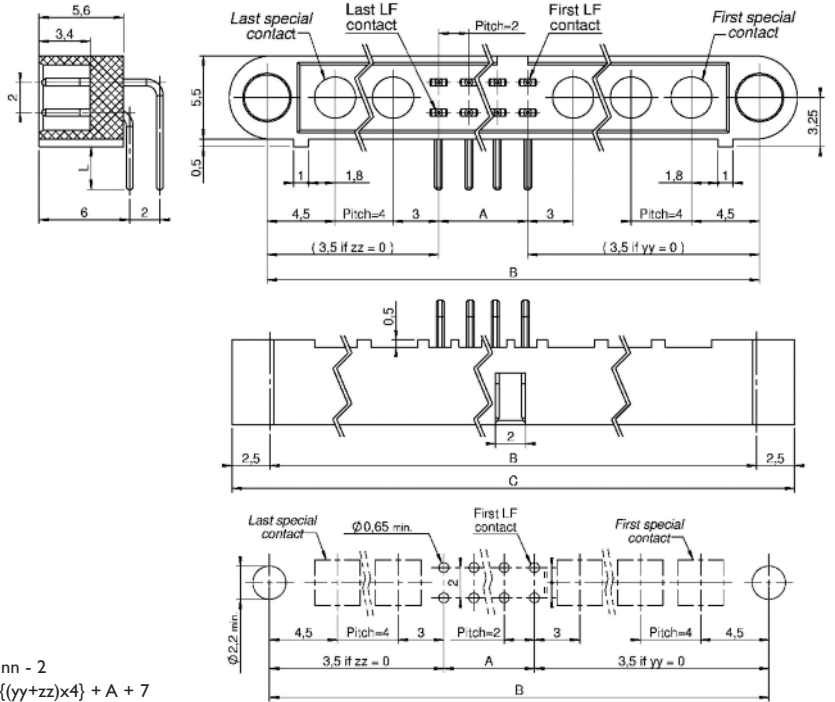

90° PCB FOR HP/HF CONTACTS ONLY



Part numbering :

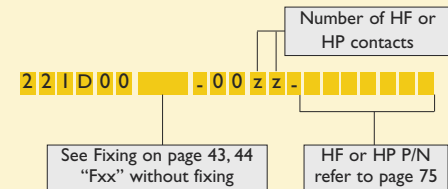

Pattern for special contact :

HF 30-1400-xx PCB lay-out

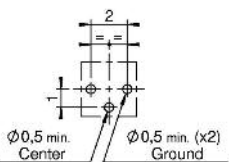

HP 30-3400-xx PCB lay-out

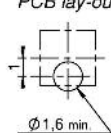

$$A = (zz \times 4) - 4$$

$$B = A + 9$$

$$C = B + 5$$

Refer to sizes information table on cover page

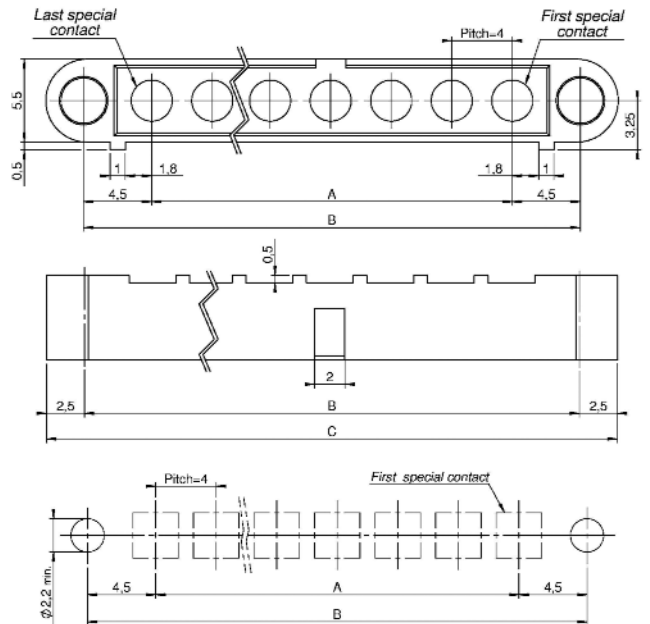

Special contacts min. : 02
max. : 15

CMM 220

Male mixed-layout

CRIMP

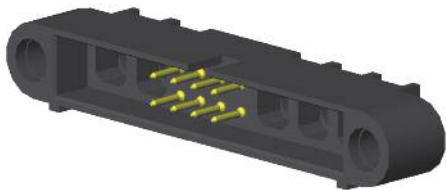

Part numbering :

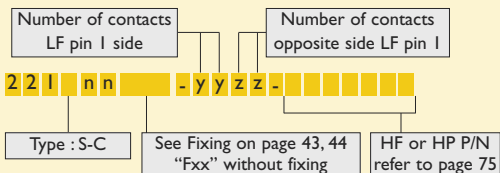

nn = number of LF contacts

Type	Gauge
S	24-28
C	22

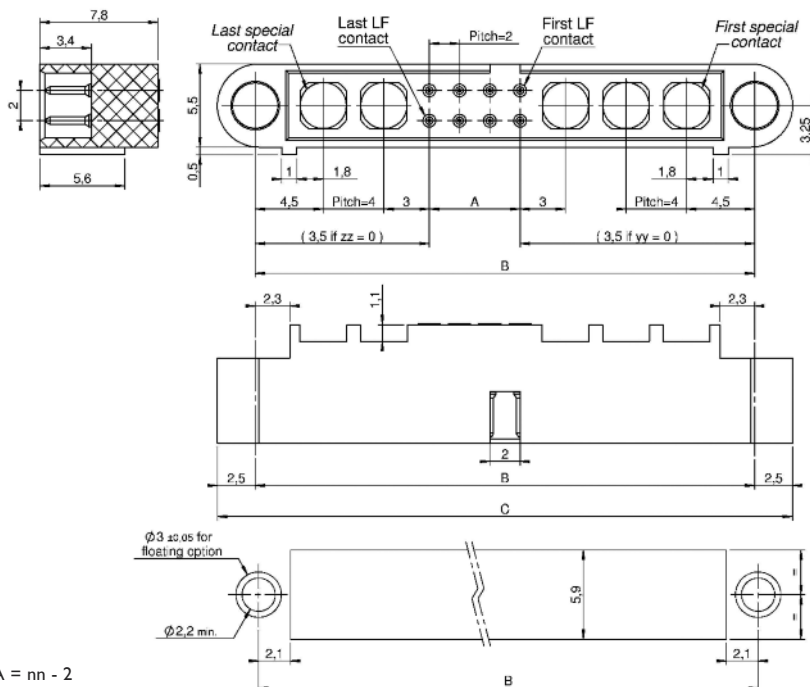
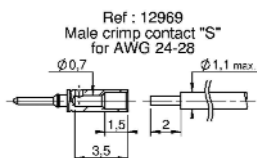
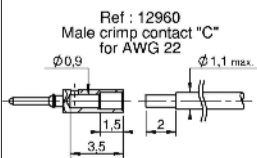

$A = nn - 2$
 $B = \{(yy+zz) \times 4\} + A + 7$
 $B_{max} = 65 \text{ mm}$
 $C = B + 5$

CRIMP FOR HP/HF CONTACTS ONLY

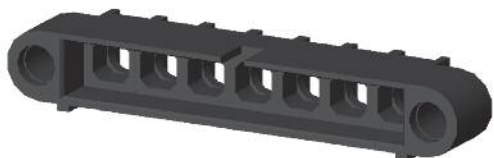

Part numbering :

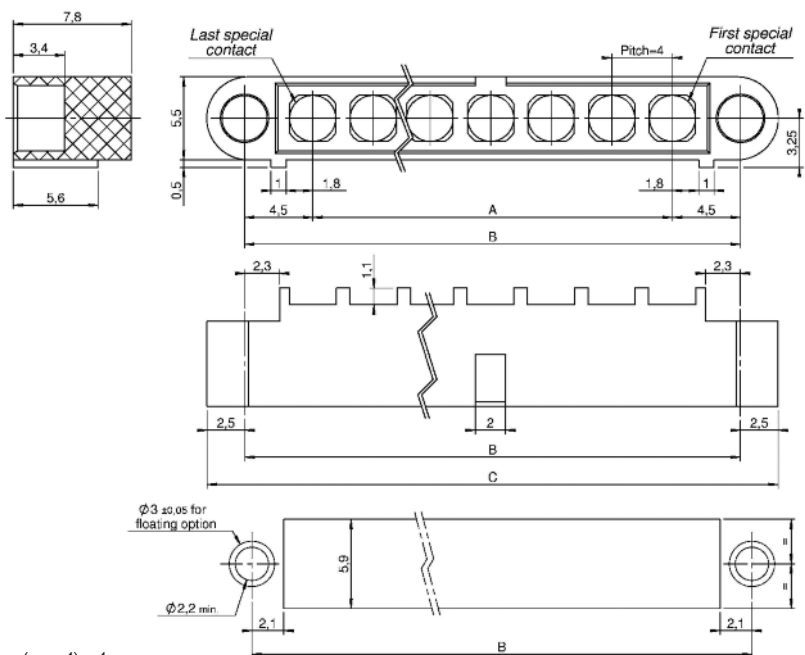
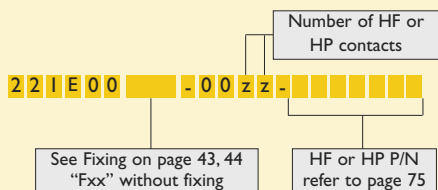

$A = (zz \times 4) - 4$
 $B = A + 9$
 $C = B + 5$

Special contacts min. : 02
max. : 15

Refer to dimension table on cover page

CMM 220

Female mixed-layout

STRAIGHT PCB



Part numbering :

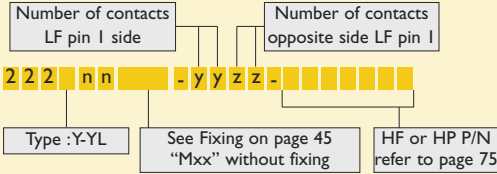

nn = number of LF contacts

Type	L
Y	3
YL	4,5

Pattern for special contact :

HF 30-2300-xx PCB lay-out

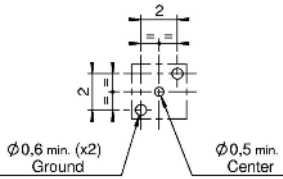

HP 30-4300-xx PCB lay-out

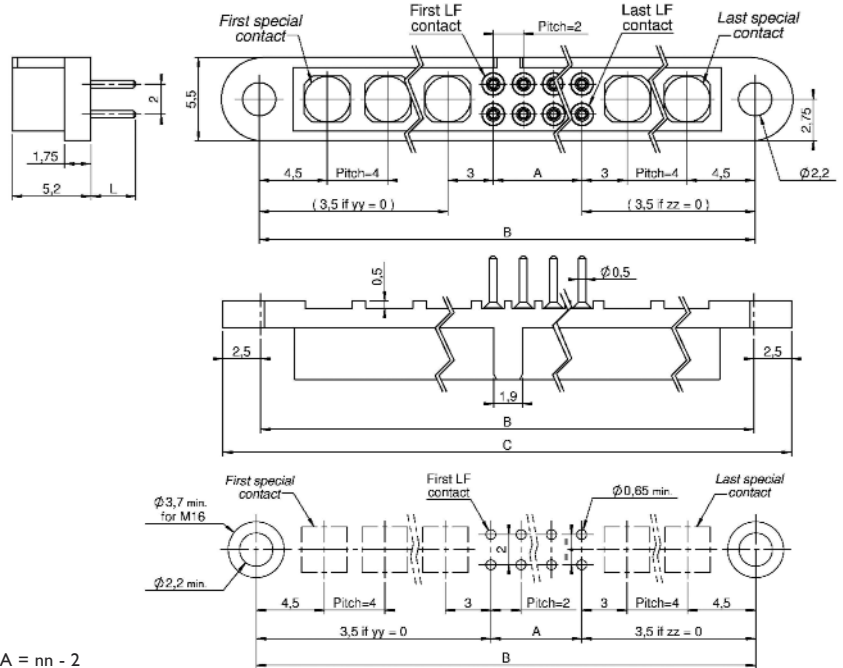
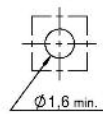

$A = nn - 2$
 $B = ((yy+zz) \times 4) + A + 7$
 $B_{max.} = 65 \text{ mm}$
 $C = B + 5$

STRAIGHT PCB FOR HP/HF CONTACTS ONLY



Part numbering :

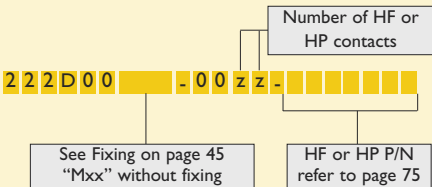

Pattern for special contact :

HF 30-2300-xx PCB lay-out

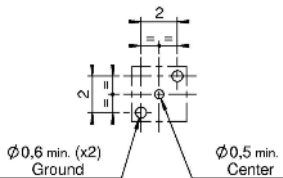

HP 30-4300-xx PCB lay-out

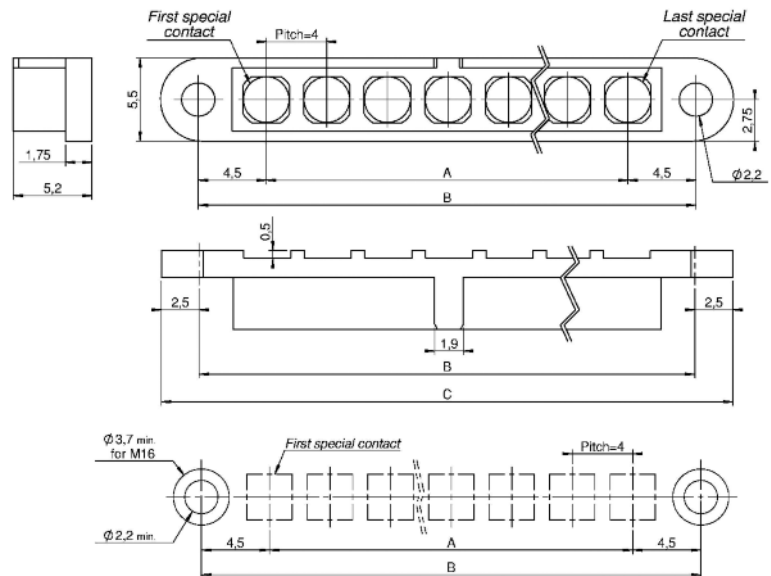
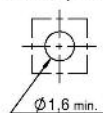

Special contacts min.: 02
max.: 15

$A = (zz \times 4) - 4$
 $B = A + 9$
 $C = B + 5$

Refer to dimension table on cover page

CMM 220

Female mixed-layout

CRIMP



Part numbering :

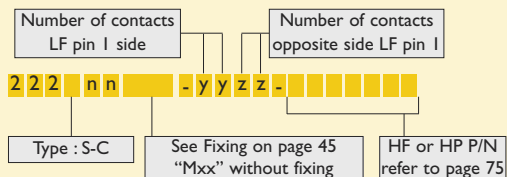

nn = number of LF contacts

Type	Gauge
S	24-28
C	22

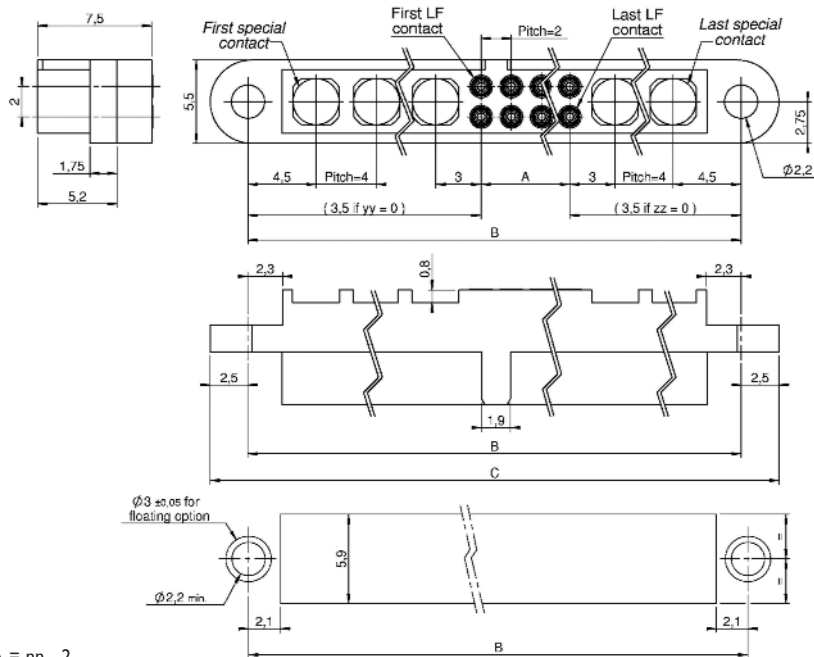
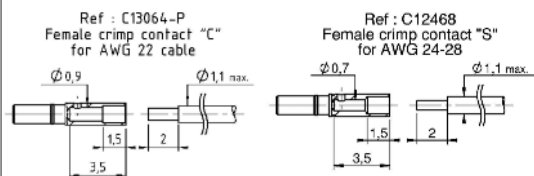

$A = nn - 2$
 $B = ((yy+zz) \times 4) + A + 7$
 $B_{max} = 65 \text{ mm}$
 $C = B + 5$

CRIMP FOR HP/HF CONTACTS ONLY



Part numbering :

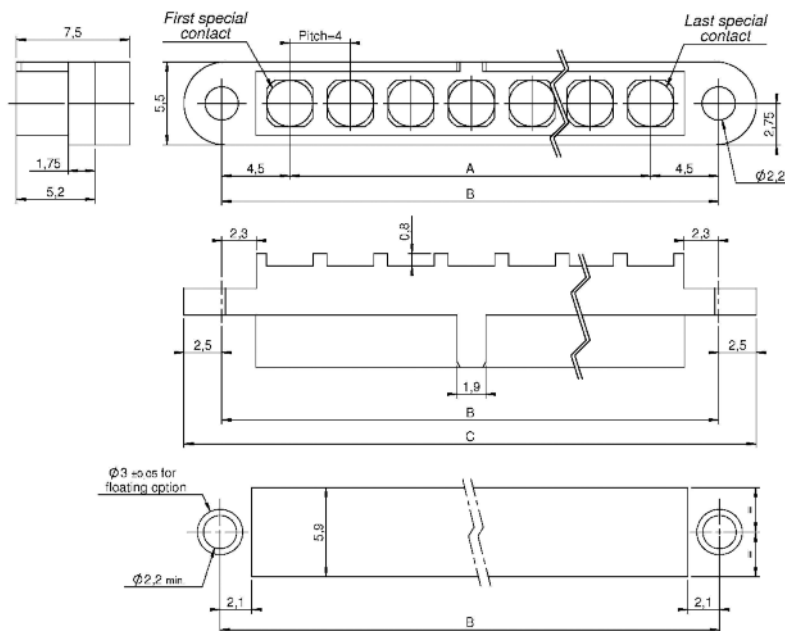
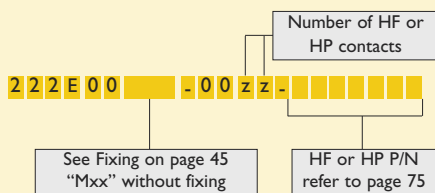

$A = (zz \times 4) - 4$
 $B = A + 9$
 $C = B + 5$

Special contacts min. : 02
max. : 15

Refer to dimension table on cover page

Fixing hardware interconnection table for CMM 220

MALE CONNECTORS CMM SERIES 220

Type of contact in connector	PCB Contacts																																		
	Type of PCB mount	Straight														90°																			
		0,8 min. 2 max.	1,5 min. 4 max.	6 max.	4 max.	2,5 max.	4,5 max.	1,6 max.	3,2 max.	Card edge only HF	Card edge HF & LF	No fixing on PCB	Racking	0,8 min 2 max	1,5 min 4 max	6 max	4 max	2,5 max	4,5 max	1,6 max	3,2 max	Floating	No fixing on PCB	Racking	With cover										
PCB thickness (mm)	F22 F22H	F24 F24H	F24L	F25	F26 F23	F30 F30H	F31 F31H	F63	F63L	F27	F34	F21	F60	F61	F62 F62H	F22	F24	F24L	F25	F26 F23	F30 F30H	F31 F31H	F63	F63L	F2xx	F21	F60	F61	F62	F28					
Housing assembly	Smooth	Straight	0,8 min. 2 max.	M12	OK	OK	OK	OK	OK	OK	OK	OK	OK	OK	OK	OK	OK	OK	OK	OK	OK	OK	OK	OK	OK	OK	OK	OK	OK	OK	OK				
			M12H	OK	OK	OK	OK	OK	OK	OK	OK	OK	OK	OK	OK	OK	OK	OK	OK	OK	OK	OK	OK	OK	OK	OK	OK	OK	OK	OK	OK	OK			
			M12L	OK	OK	OK	OK	OK	OK	OK	OK	OK	OK	OK	OK	OK	OK	OK	OK	OK	OK	OK	OK	OK	OK	OK	OK	OK	OK	OK	OK	OK			
		Straight	1,5 min. 4 max.	M12LH	OK	OK	OK	OK	OK	OK	OK	OK	OK	OK	OK	OK	OK	OK	OK	OK	OK	OK	OK	OK	OK	OK	OK	OK	OK	OK	OK	OK	OK		
			M49																																
			M49H																																
	Locked	Straight	1,5 min. 2,5 max.	M46							OK	OK																							
			M46H								OK	OK																							
			M47								OK	OK																							
		90°	1,5 min. 4 max.	M47H							OK	OK																							
			M21	OK	OK	OK		A	A	A								OK	OK	OK		A	A	A			OK	OK					B		
			M21L	OK	OK	OK		A	A	A								OK	OK	OK		A	A	A			OK	OK					B		
Without	90°	1,6	M48											OK																		OK			
		2	M48M												OK																	OK			
		M48L													OK																		OK		
	Without	M16	OK	OK	OK		OK	OK	OK																								OK		
		M11	OK	OK	OK		OK	OK	OK																									OK	
		M11	OK	OK	OK		OK	OK	OK																									OK	
Contacts on cable	Smooth	Straight	0,8 min. 2 max.	M12	OK	OK	OK	OK	OK	OK	OK	OK	OK	OK	OK	OK	OK	OK	OK	OK	OK	OK	OK	OK	OK	OK	OK	OK	OK	OK	OK	OK			
			M12L	OK	OK	OK	OK	OK	OK	OK	OK	OK	OK	OK	OK	OK	OK	OK	OK	OK	OK	OK	OK	OK	OK	OK	OK	OK	OK	OK	OK	OK	OK		
			M49																																
		Floating	M1xx	OK	OK	OK	OK	OK	OK	OK																									
			M46								OK	OK																							
			M47								OK	OK																							
	Locked	90°	1,5 min. 2,5 max.	M46						OK	OK																								
			M47							OK	OK																								
			M21	OK	OK	OK		A	A	A								OK	OK	OK		A	A	A			OK	OK						B	
		Without	M21L	OK	OK	OK		A	A	A								OK	OK	OK		A	A	A			OK	OK						B	
			M48													OK																		OK	
			M48M													OK																		OK	
With cover	Without	M16	OK	OK	OK		OK	OK	OK																								OK		
		M11	OK	OK	OK		OK	OK	OK																								OK		
		M18	OK	OK	OK		B	B	B																								OK		
	With cover	M18	OK	OK	OK		B	B	B																								OK		

Make it a habit! Use easy & automatic configurators for CMM micro-connectors single part and mating-half construction on www.nicomatic.com.

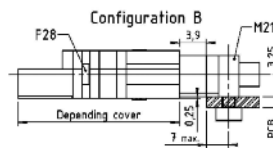
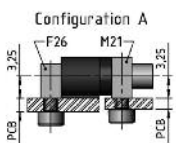

Recommended Torque : 0,2 N/m
Except 0,4 N/m for M46/M47







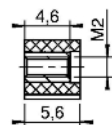

FIXING HARDWARE FOR CMM 220 MALE

REFERENCE	ASSEMBLY ON PCB	OVERALL DIMENSIONS	RECOMMENDATION
F27			F27 : CMM male : Card edge for HF contact 30-1500-CMM
F34			F34 : CMM male : Card edge LF contact or mixed
F28			F28 : CMM male : S-C (E : straight)

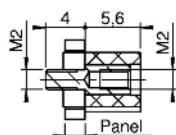
Fixing for CMM 220 male

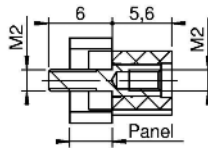
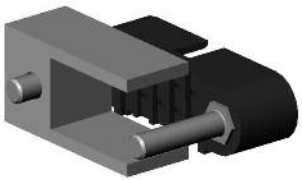
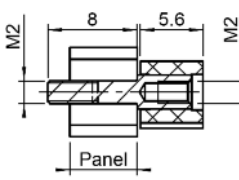
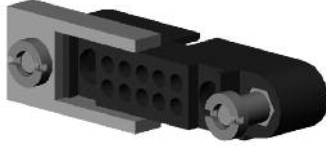
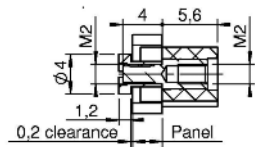
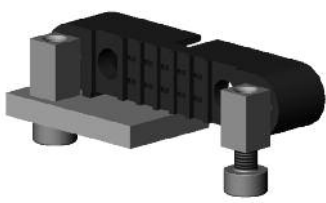
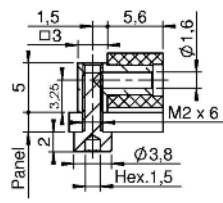
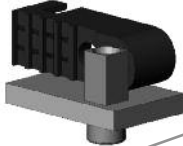
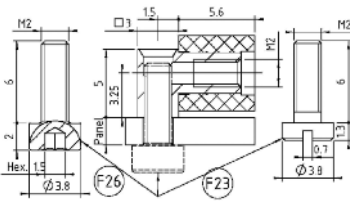
FIXING HARDWARE FOR CMM 220 MALE

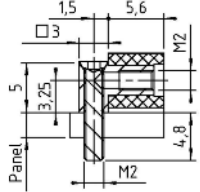
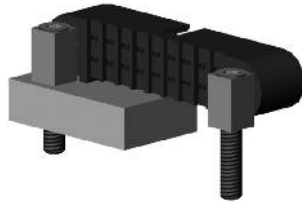
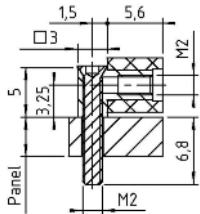
REFERENCE	ASSEMBLY ON PCB	OVERALL DIMENSIONS	RECOMMENDATION
F21	Straight on PCB 		F21 : CMM male : Y-YL-TS-C (D-E : straight)
F22	Straight on PCB 0,8 min / 2 max 		F22 : CMM male : Y-TS-C (D-E : straight) F22H : CMM male : Y-T (D : straight)
F22H			
F24	Straight on PCB 1,5 min / 4 max 		F24 : CMM male : YL-TS-C (D-E : straight) F24H : CMM male : YL-T (D : straight)
F24H			
F24L	Straight on PCB 6 max 		F24L : CMM male : T-TL (D-E : straight)
F2xx xx = (PCB thickness + 0,2 mm) x 10 Example : for 3 mm PCB, the reference is F232 (3 + 0,2) x 10 = 32 xx = 32	Straight on PCB with floating option 		F2xx : CMM male : S-C (E : straight)
F25	90° on PCB 		F25 : CMM male : V-VL-R-S-C-E (D : 90°)
F26	90° on PCB 		F26/F23 : CMM male : V-VL-R-S-C-E (D : 90°)
F23			
F30	90° on PCB 2,5 max. 		F30 & F30H : CMM male : V-R-C-S-E (D : 90°)
F30H			
F31	90° on PCB 4,5 max. 		F31 & F31H : CMM male : VL-R-C-S-E (D : 90°)
F31H			

Please refer to the CMM Catalogue Guidelines for any other fixing not listed here.

Fixing for CMM 220 female

FIXING HARDWARE FOR CMM 220 FEMALE

		HEXAGONAL NUT	STANDARD NUT	"W" CODE FOR ADDITIONAL WASHER		
REFERENCE	ASSEMBLY ON PCB	OVERALL DIMENSIONS		RECOMMENDATION		
M16 M11	Straight on PCB 			M16/M11 : CMM Female : Y-YL-TS-C-E (D : straight)		
M12 M12H	Straight on PCB 0,8 min / 2 max 			M12 : CMM female : Y-TS-C (D-E : straight) M12H : CMM female : Y-T (D : straight)		
M12L M12LH	Straight on PCB 1,5 min / 4 max 			M12L : CMM female : Y-TS-C (D-E : straight) M12LH : CMM female : YL-T (D : straight)		
M1xx xx = (PCB thickness + 0,2 mm) x 10 Example : for 3 mm PCB, the reference is M132 (3 + 0,2) x 10 = 32 xx = 32	Straight on PCB with floating option 			M1xx : CMM female : S-C (E : straight)		
M21 for PCB 1,6 mm (L = 4 mm) M21L for PCB 3,2 mm (L = 5 mm)	90° on PCB 			M21 : CMM Female : V-R-S-C-E (D : 90°) M21L : CMM Female : VL-R-S-C-E (D : 90°)		
M18	Cover option 			M18 : CMM female : S-C (E : straight) 		

Please refer to the CMM Catalogue Guidelines for any other fixing not listed here.

Other fixing hardware for CMM 220

FIXING HARDWARE FOR CMM 220 FEMALE/MALE

REFERENCE	ASSEMBLY ON PCB	OVERALL DIMENSIONS	RECOMMENDATION
M46	Straight on PCB 1,5 min. / 2,5 max. 		M46 : CMM female : Y-TS-C (D-E : straight)
M46H			
M47	Straight on PCB 1,5 min. / 4 max. 		M47 : CMM female : YL-TS-C (D-E : straight)
M47H			
M48 for PCB 1,6 mm (L = 3 mm)	90° on PCB 		M48 / M48M / M48L : CMM female : V-VL-R-S-C-E (D : 90°)
M48M for PCB 2 mm (L = 4 mm)			
M48L for PCB 3,2 mm (L = 5 mm)			
M49	Straight on PCB 		M49 : CMM female : Y-TS-C (D-E : straight)
M49H			
F60	Straight on PCB 		F60 : CMM male : Y-YL-TS-C-E (D : straight)
F61	Straight on PCB 		F61 : CMM male : Y-YL-TS-C-E (D : straight)
F62	Racking 		F62 : CMM male : Y-TS-C (D-E : straight)
F62H			
F63 for PCB 1,6 mm	90° on PCB 		F63 : CMM male : V-R-S-C-E (D : 90°)
F63L for PCB 3,2 mm			

M46 M46H M47 M47H

fixing hardware PCB layout

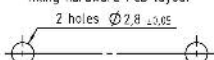

Distance between



While screwing the fixing nut, maintain the insert with screwdriver

HP : High Power contact series 30

MALE STRAIGHT ON CABLE P/N 30-33xx (solder or crimp)

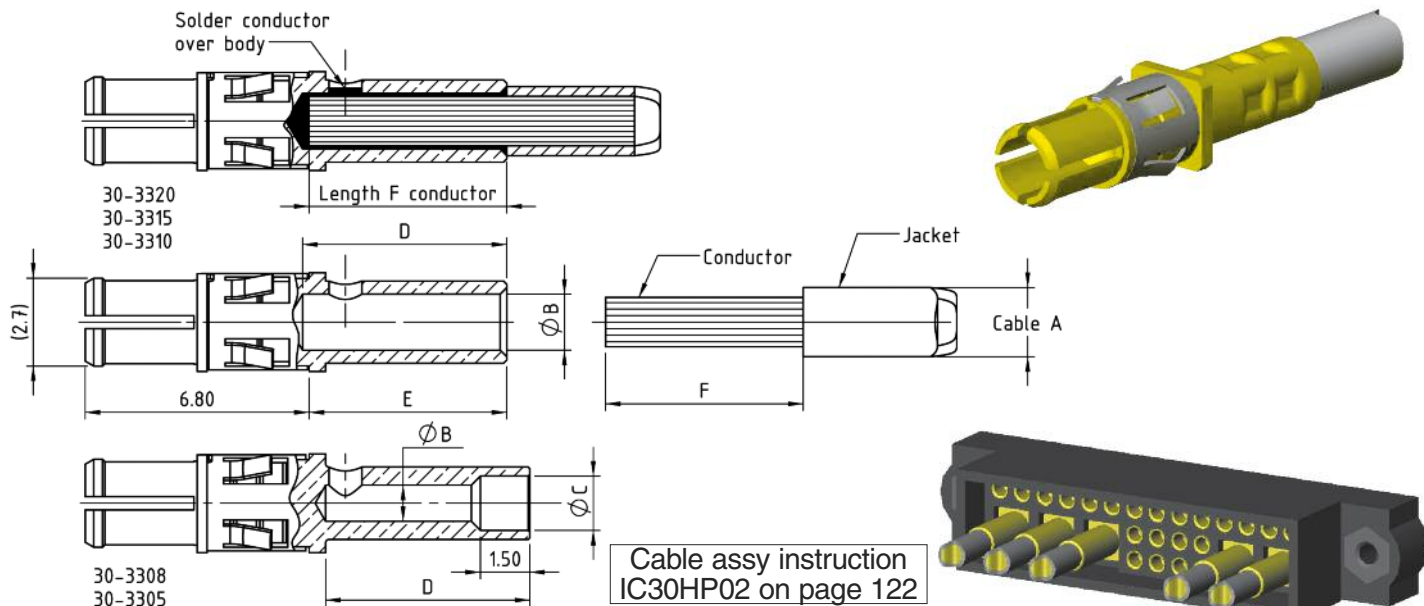

Loaded	Unloaded	Ampere	Cable A				ØB	ØC	Length D hole	Length E body	Length F conductor	Solder	Crimp by HX3 Hexagone size/Dies	Crimp by AF8
			AWG 20	AWG 18	AWG 16	AWG 14								
3305	30-3305	5A	X				1,1 mm	1,65 mm	6,2 mm	6,7 mm	4,5 mm	OK	Hex. 1,9 mm/C14923	OK
3308	30-3308	8A		X			1,35 mm	1,85 mm	6,2 mm	6,7 mm	4,5 mm	OK	Hex. 1,9 mm/C14923	OK
3310	30-3310	10A	X	X	X		1,7 mm		6,2 mm	6 mm	6 mm	OK		OK
3315	30-3315	15A				X	2 mm		6,2 mm	6 mm	6 mm	OK		OK
3320	30-3320	20A				X	2,6 mm		5,5 mm	6 mm	5,3 mm	OK		OK

FEMALE STRAIGHT ON CABLE P/N 30-43xx (solder or crimp)

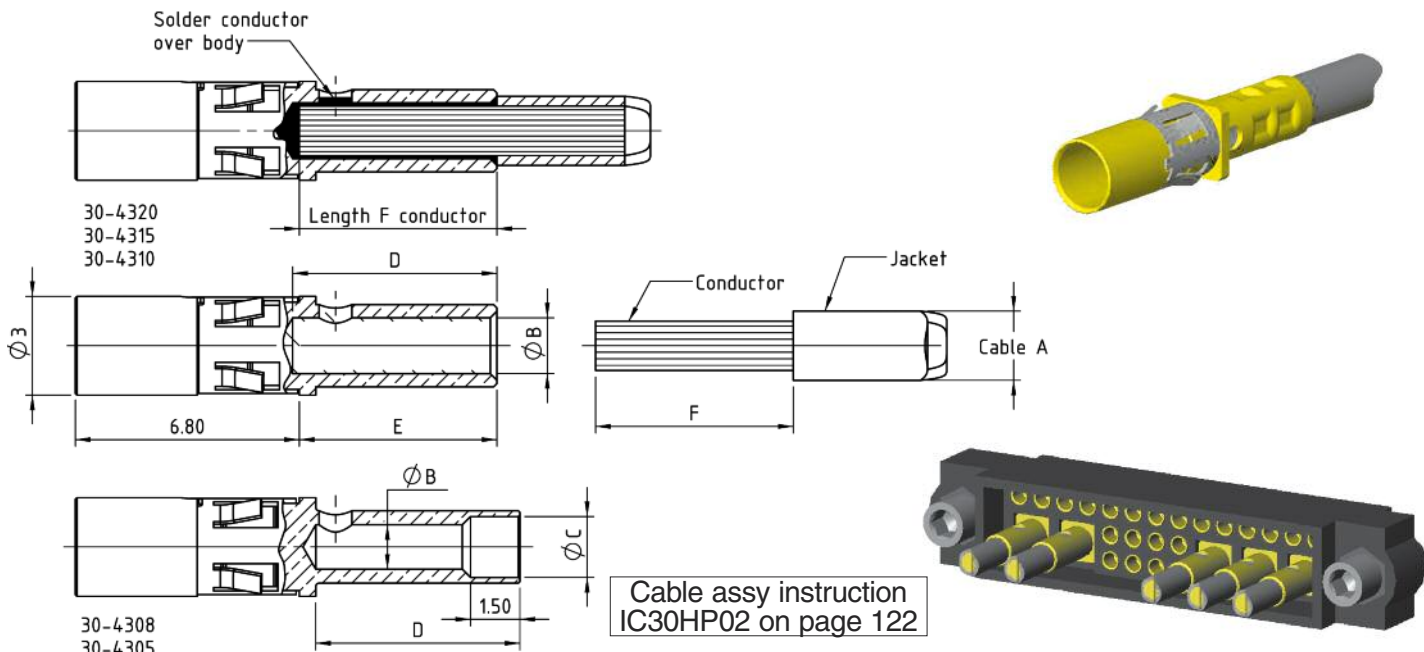

Loaded	Unloaded	Ampere	Cable A				ØB	ØC	Length D hole	Length E body	Length F conductor	Solder	Crimp by HX3 Hexagone size/Dies	Crimp by AF8
			AWG 20	AWG 18	AWG 16	AWG 14								
4305	30-4305	5A	X				1,1 mm	1,65 mm	6,2 mm	6,7 mm	4,5 mm	OK	Hex. 1,9 mm/C14923	OK
4308	30-4308	8A		X			1,35 mm	1,85 mm	6,2 mm	6,7 mm	4,5 mm	OK	Hex. 1,9 mm/C14923	OK
4310	30-4310	10A	X	X	X		1,7 mm		6,2 mm	6 mm	6 mm	OK		OK
4315	30-4315	15A				X	2 mm		6,2 mm	6 mm	6 mm	OK		OK
4320	30-4320	20A				X	2,6 mm		5,5 mm	6 mm	5,3 mm	OK		OK

HF : High Frequency contacts series 22

HP : High Power contacts series 22

FOR CMM 340

INSERTION

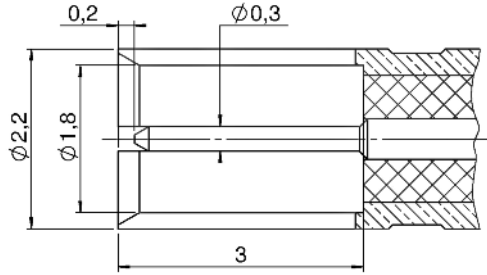

HF female contact insertion

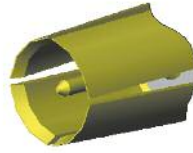

The special contact gender is determined by the body and not by the central contact

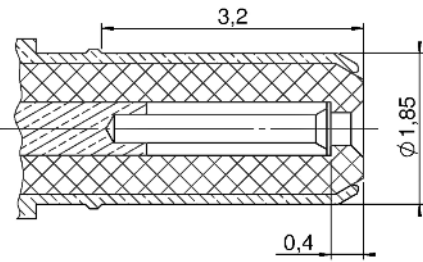

HF male contact insertion

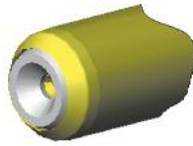

PART NUMBERING FOR PCB HF & HP SPECIAL CONTACTS

These two digits are linked to the connector. Do not use them inside a CMM part number when loaded. All dash signs also disappear

Contact type:
3 = straight
4 = right angle
5 = SMT 90°
6 = SMT straight

Termination length
"12" = 1st row 3mm
"22" = 2nd row 3mm
"14" = 1st row 4.5mm
"24" = 2nd row 4.5mm
"..."

22 - 00 -

Coaxmatic 22™
1 = male coax
2 = female coax
3 = high power male
4 = high power female

PART NUMBERING FOR HF & HP SPECIAL CONTACTS ON-CABLE

These two digits are linked to the connector. Do not use them inside a CMM part number when loaded. All dash signs also disappear

For HF contacts only Inner contact
Z = solder
S = crimp

For HF contacts only shield
Z = solder
S = crimp

Contact type:
3 = straight
"..."

Use these 2 digits only with 1.2mm dia. cables mounted on a HF straight contact
Crimp shield type: 01 = refer to page 92 02 = refer to page 92

22 - 3 - Z - 75 -

Special contacts :
1 = male HF
2 = female HF
3 = male HP
4 = female HP

Use these 2 digits only with 75 Ohm cables

Contact termination:
10 = for HP 10A
12 = for HF cable 1.2mm
20 = for HF cable 2mm

HF : High Frequency contacts series 22

MALE 90° PCB P/N 22-1400-xx

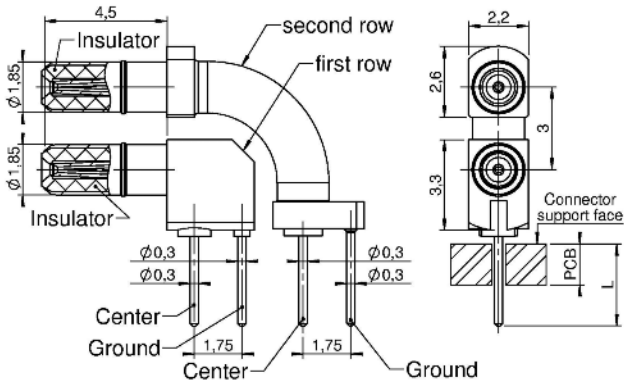

	Loaded		Loaded	Length L
First row	140012	it mounted in same connector	140002	3 mm
Second row	140022			
First row	140014	it mounted in same connector	140004	4,5 mm
Second row	140024			

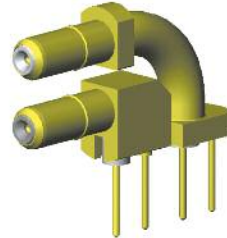

PCB Lay-out

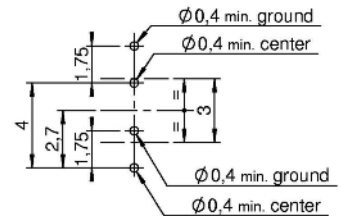

PCB LAYOUT 22-1400-xx

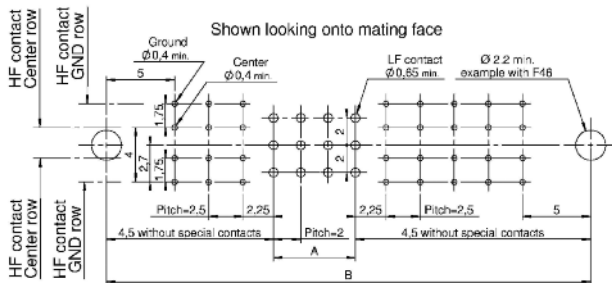

$$A = \left\{ \frac{(nn \times 2)}{3} \right\} - 2$$

if yy or zz ≠ 0 :

$$B = \left\{ \left(\frac{(yy) + (zz)}{2} \right) - 2 \right\} \times 2,5 + 14,5 + A$$

if yy or zz = 0 :

$$B = \left\{ \left(\frac{(yy) + (zz)}{2} \right) - 1 \right\} \times 2,5 + 11,75 + A$$

B max. = 87

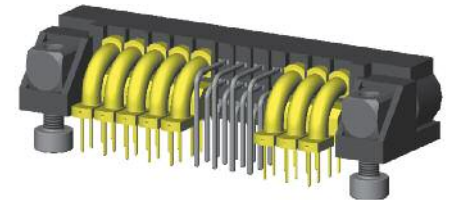

FEMALE 90° PCB P/N 22-2400-xx

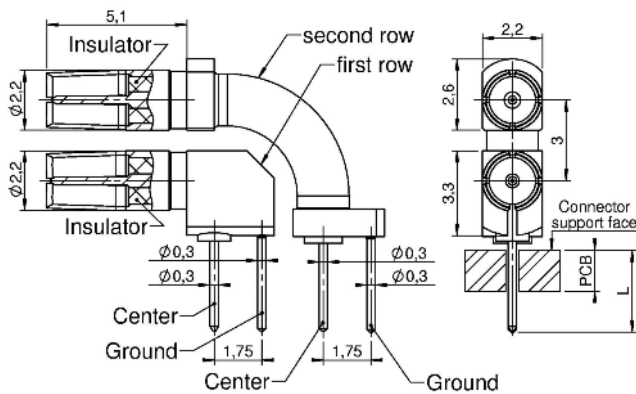

	Loaded		Loaded	Length L
First row	240012	it mounted in same connector	240002	3 mm
Second row	240022			
First row	240014	it mounted in same connector	240004	4,5 mm
Second row	240024			

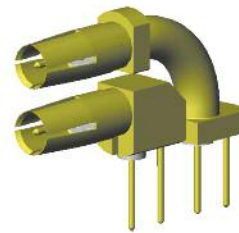

PCB Lay-out

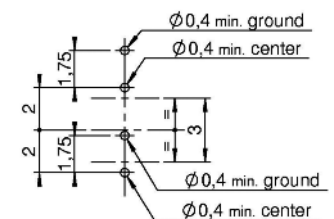

PCB LAYOUT 22-2400-xx

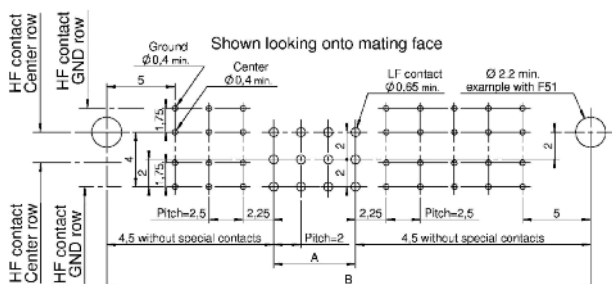

$$A = \left\{ \frac{(nn \times 2)}{3} \right\} - 2$$

if yy and zz ≠ 0 :

$$B = \left\{ \left(\frac{(yy) + (zz)}{2} \right) - 2 \right\} \times 2,5 + 14,5 + A$$

if yy or zz = 0 :

$$B = \left\{ \left(\frac{(yy) + (zz)}{2} \right) - 1 \right\} \times 2,5 + 11,75 + A$$

B max. = 87

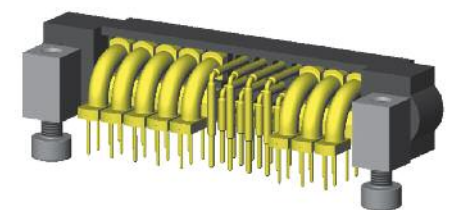

HF : High Frequency contacts series 22

MALE STRAIGHT TO CRIMP ON CABLE Ø 1.2 P/N 22-1312-ZS-xx

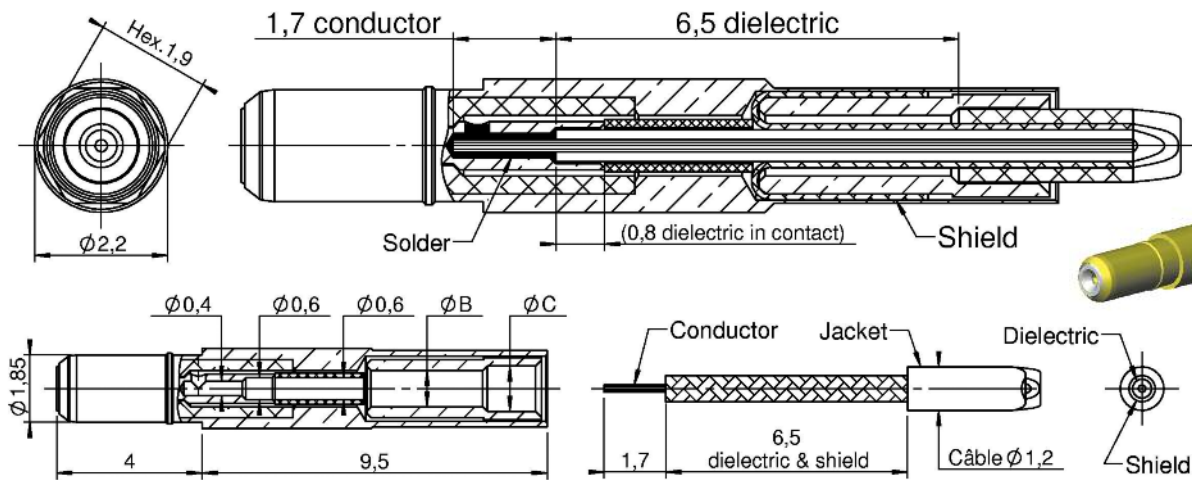

Cable assy instruction IC22HF01 on page 116

Loaded	Unloaded	ØB	ØC	
I312ZS01	22-1312-ZS-01	1 mm	1,25 mm	For cable type NEXANS 50VMTX
I312ZS02	22-1312-ZS-02	0,85 mm	1,15 mm	For cable type AXON SM50

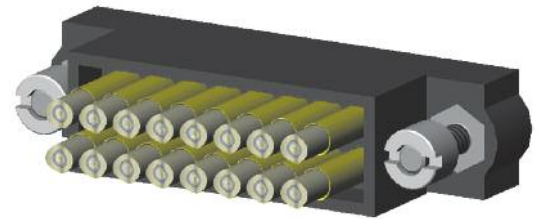

FEMALE STRAIGHT TO CRIMP ON CABLE Ø 1.2 P/N 22-2312-ZS-xx

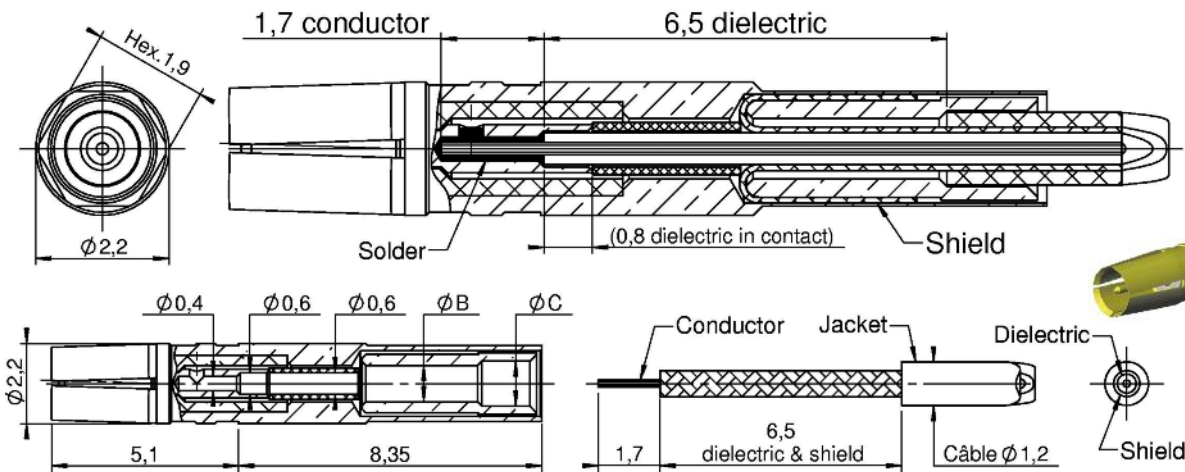

Cable assy instruction IC22HF02 on page 117

Loaded	Unloaded	ØB	ØC	
2312ZS01	22-2312-ZS-01	1 mm	1,25 mm	For cable type NEXANS 50VMTX
2312ZS02	22-2312-ZS-02	0,85 mm	1,15 mm	For cable type AXON SM50

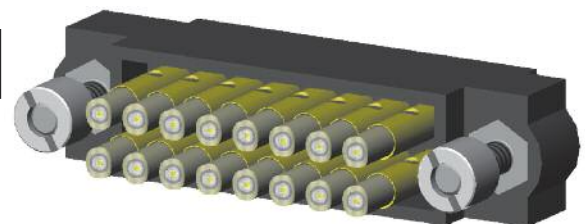

HF : High Frequency contacts series 22

MALE STRAIGHT ON CABLE P/N 22-1320-ZZ

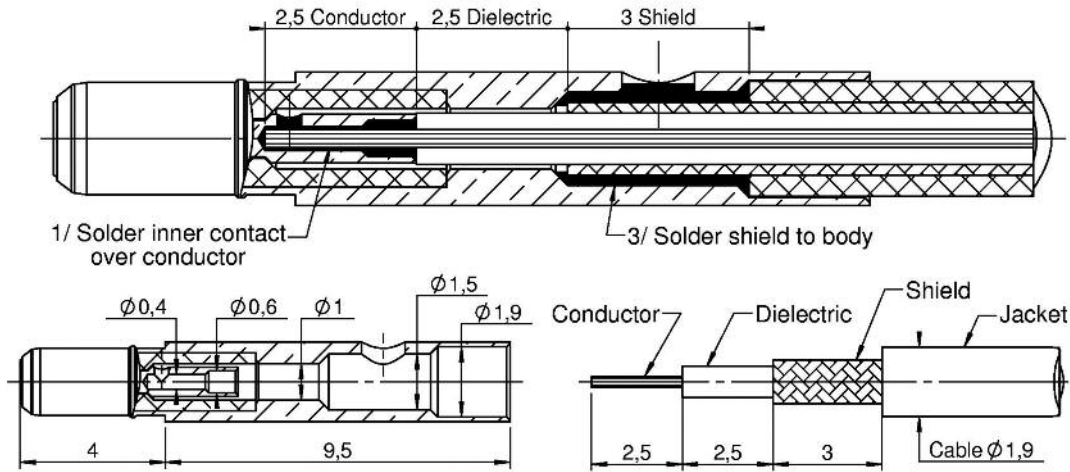

- 1/ Solder inner contact over conductor.
- 2/ Push cable with inner contact in body.
- 3/ Solder shield to body.

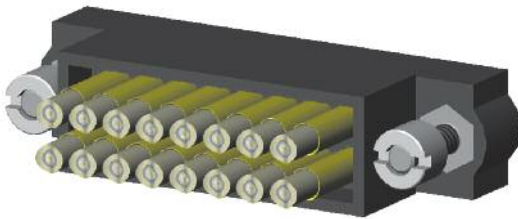

Loaded	Unloaded
1320ZZ	22-1320-ZZ

FEMALE STRAIGHT ON CABLE P/N 22-2320-ZZ

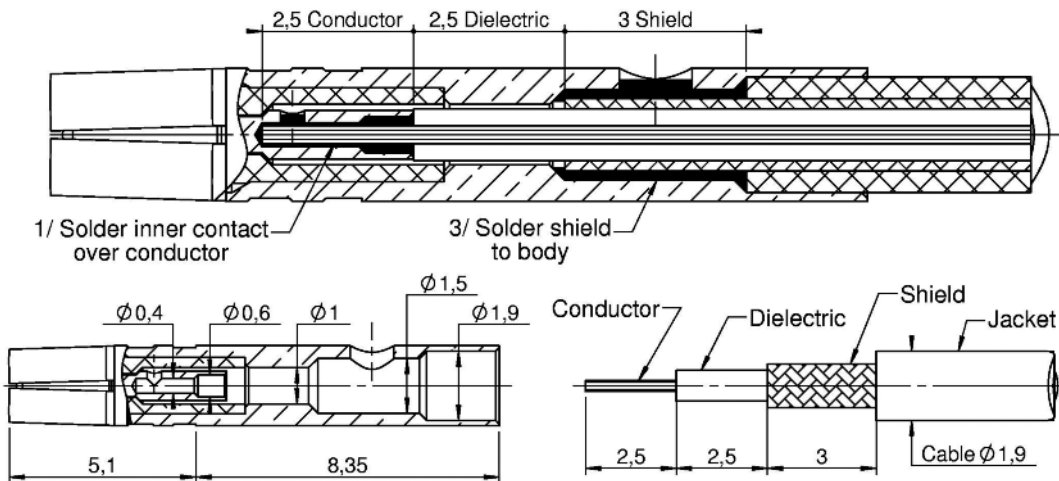

- 1/ Solder inner contact over conductor.
- 2/ Push cable with inner contact in body.
- 3/ Solder shield to body.

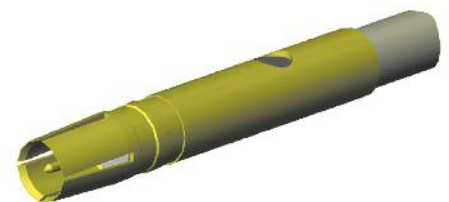
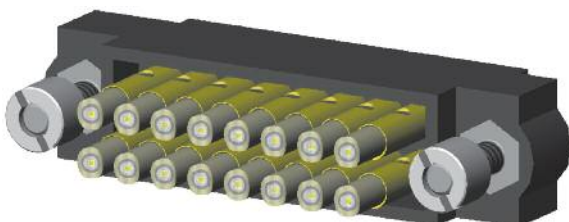

Loaded	Unloaded
2320ZZ	22-2320-ZZ

HP : High power contacts series 22

MALE STRAIGHT ON PCB P/N 22-3300-xx

Loaded	Length L
330012	3 mm
330014	4,5 mm

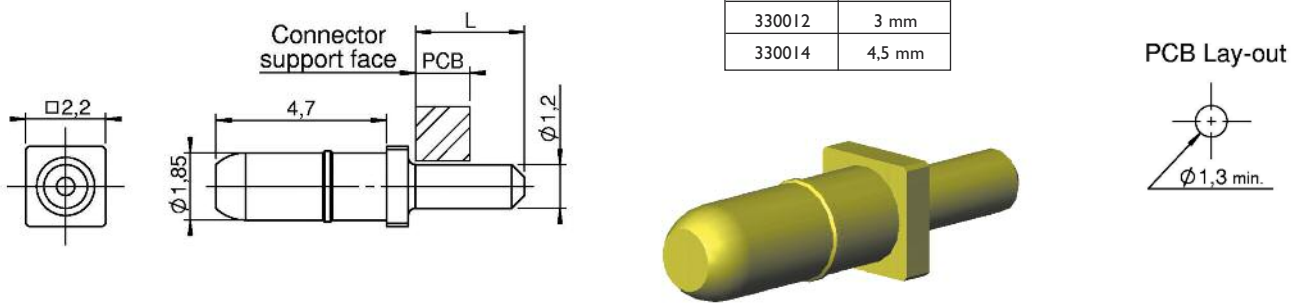

Connector support face PCB L $\phi 1,2$ 4,7 $\phi 1,85$ $\square 2,2$

PCB Lay-out $\phi 1,3 \text{ min.}$

FEMALE STRAIGHT ON PCB P/N 22-4300-xx

Loaded	Length L
430012	3 mm
430014	4,5 mm

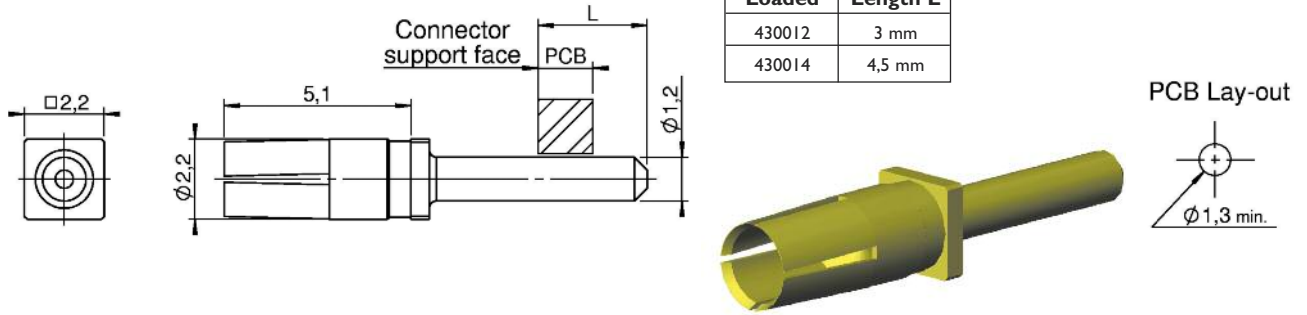

Connector support face PCB L $\phi 1,2$ 5,1 $\phi 2,2$ $\square 2,2$

PCB Lay-out $\phi 1,3 \text{ min.}$

PCB LAYOUT 22-3300-xx & 22-4300-xx

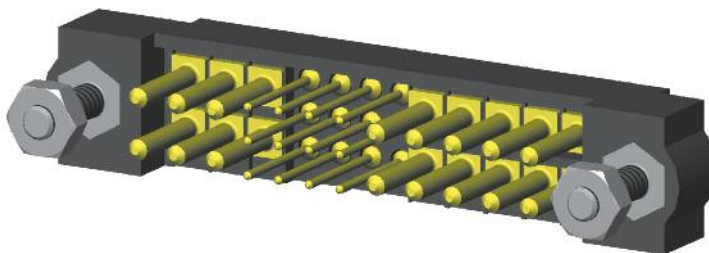
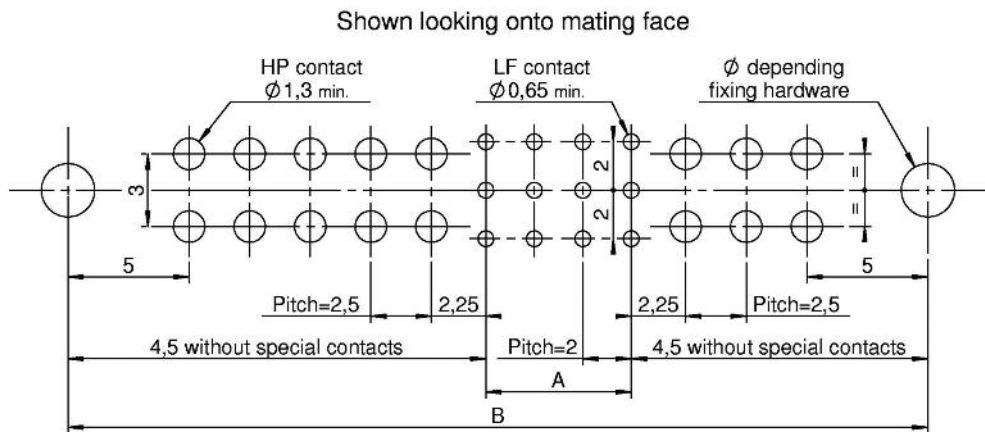

$$A = \left\{ \frac{(nn \times 2)}{3} \right\} - 2$$

if yy and zz $\neq 0$:

$$B = \left\{ \left(\frac{(yy) + (zz)}{2} \right) - 2 \right\} \times 2,5 + 14,5 + A$$

if yy or zz = 0 :

$$B = \left\{ \left(\frac{(yy) + (zz)}{2} \right) - 1 \right\} \times 2,5 + 11,75 + A$$

B max. = 87

HP : High power contacts series 22

MALE 90° PCB P/N 22-3400-xx

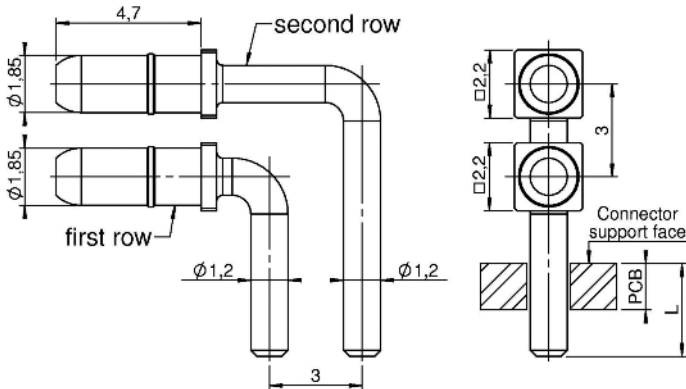

	Loaded		Loaded	Length L
First row	340012	it mounted in same connector	340002	3 mm
Second row	340022			
First row	340014	it mounted in same connector	340004	4,5 mm
Second row	340024			

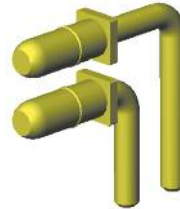

PCB Lay-out

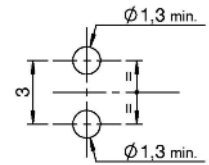

FEMALE 90° PCB P/N 22-4400-xx

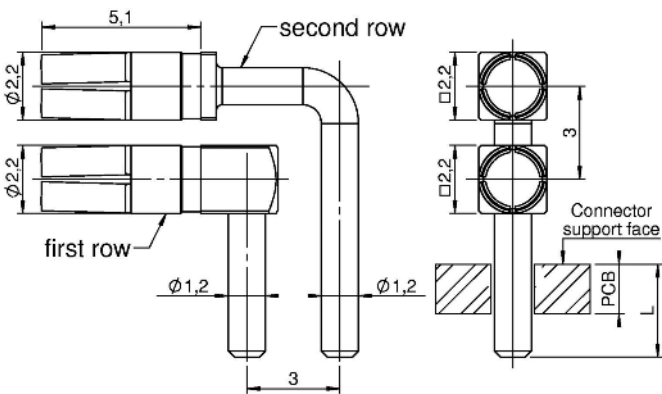

	Loaded		Loaded	Length L
First row	440012	it mounted in same connector	440002	3 mm
Second row	440022			
First row	440014	it mounted in same connector	440004	4,5 mm
Second row	440024			

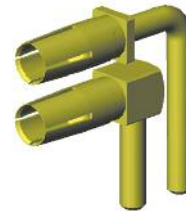

PCB Lay-out

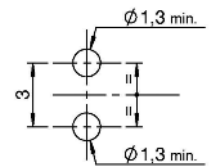

PCB LAYOUT 22-3400-xx & 22-4400-xx

Shown looking onto mating face

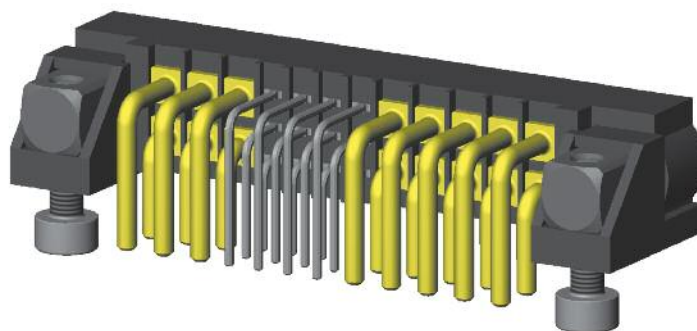
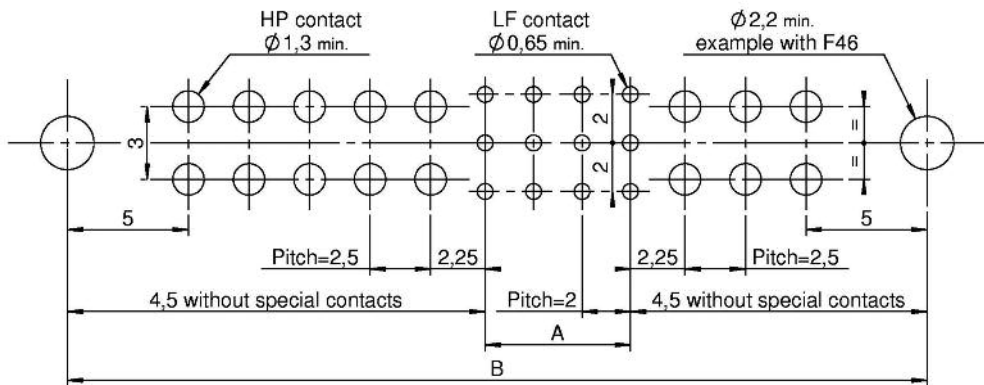

$$A = \left\lfloor \frac{(nx \times 2)}{3} \right\rfloor - 2$$

if yy and zz ≠ 0 :

$$B = \left\lfloor \left(\frac{(yy) + (zz)}{2} \right) - 2 \right\rfloor \times 2,5 + 14,5 + A$$

if yy or zz = 0 :

$$B = \left\lfloor \left(\frac{(yy) + (zz)}{2} \right) - 1 \right\rfloor \times 2,5 + 11,75 + A$$

B max. = 87

HP : High power contacts series 22

MALE STRAIGHT ON CABLE P/N 22-33XX (solder & crimp)

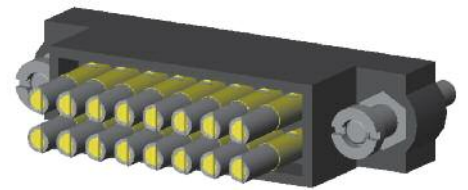
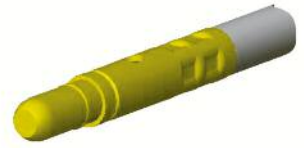
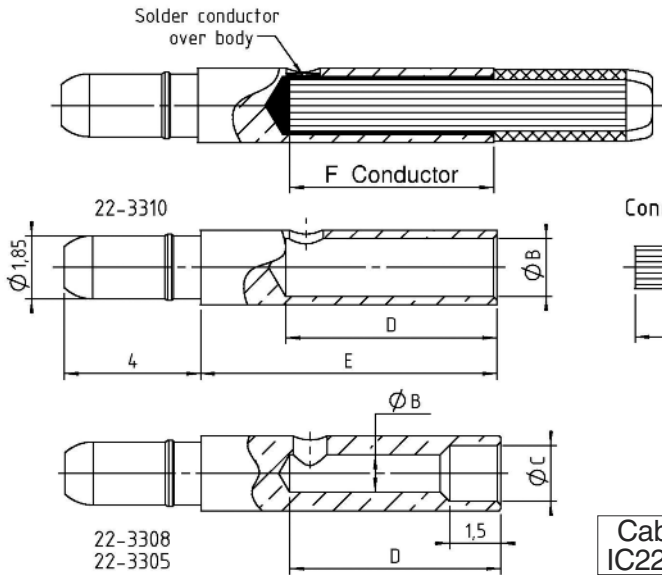

Cable assy instruction IC22HP02 on page 121

Loaded	Unloaded	Ampere	Cable A			ØB	ØC	Length D hole	Length E body	Length F conductor	Solder	Crimpsy HX3 Hexagone size/Dies	Crimp by AF8
			AWG 20	AWG 18	AWG 16								
3305	22-3305	5A	X			1,1 mm	1,65 mm	6,2 mm	8,8 mm	4,5 mm	OK	Hex. 1,9 mm/C14923	OK
3308	22-3308	8A		X		1,35 mm	1,85 mm	6,2 mm	8,8 mm	4,5 mm	OK	Hex. 1,9 mm/C14923	OK
3310	22-3310	10A	X	X	X	1,7 mm		6,2 mm	8,8 mm	6 mm	OK	Hex. 1,9 mm/C14923*	OK

* only for AWG 16

FEMALE STRAIGHT ON CABLE P/N 22-43XX (solder & crimp)

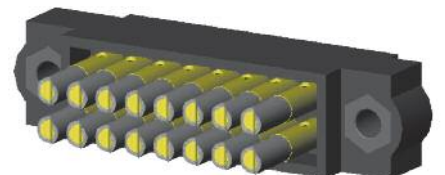
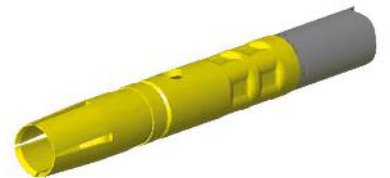
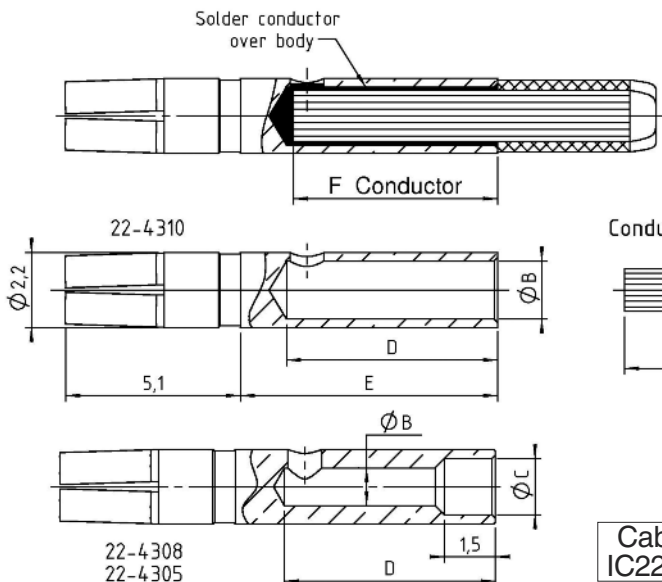

Cable assy instruction IC22HP02 on page 121

Loaded	Unloaded	Ampere	Cable A			ØB	ØC	Length D hole	Length E body	Length F conductor	Solder	Crimpsy HX3 Hexagone size/Dies	Crimp by AF8
			AWG 20	AWG 18	AWG 16								
4305	22-4305	5A	X			1,1 mm	1,65 mm	6,2 mm	7,7 mm	4,5 mm	OK	Hex. 1,9 mm/C14923	OK
4308	22-4308	8A		X		1,35 mm	1,85 mm	6,2 mm	7,7 mm	4,5 mm	OK	Hex. 1,9 mm/C14923	OK
4310	22-4310	10A	X	X	X	1,7 mm		6,2 mm	7,7 mm	6 mm	OK	Hex. 1,9 mm/C14923*	OK

* only for AWG 16

Tools

DANIELS MH800 TOOL AND POSITIONER P/N K1131 & K1692

Tools reference	Barrel
DANIELS MH800 only	MH800
Positioner K1692 only	C12929
Positioner K1131 only	K1131
DANIELS MH800 & K1131	C12237
DANIELS MH800 & K1692	C14925



Crimp barrel accommodation for LF contacts					
Hand crimp tool reference	Positioner	Contacts type	Contacts reference	Wire size (AWG)	Crimp tool setting
DANIELS MH800	K1692	Male C	I2960	22	6
DANIELS MH800	K1692	Male S	I2969	24	7
DANIELS MH800	K1692	Male S	I2969	26 & 28	6
DANIELS MH800	K1692	Female C	C13064-P	22	6
DANIELS MH800	K1692	Female S	C12468	24	7
DANIELS MH800	K1692	Female S	C12468	26 & 28	6

Crimp barrel accommodation for central contact HF30 series			
Hand crimp tool reference	Positioner	Conductor	Crimp tool setting
DANIELS MH800	K1131	Ø 0,30	2 & 3
DANIELS MH800	K1131	Ø 0,50	3 & 4

DANIELS AF8 TOOL P/N 16459

Tools reference	Reference Nicomatic
DANIELS AF8 only	16459
DANIELS AF8 + C16460	C16462
DANIELS AF8 + C16461	C16463

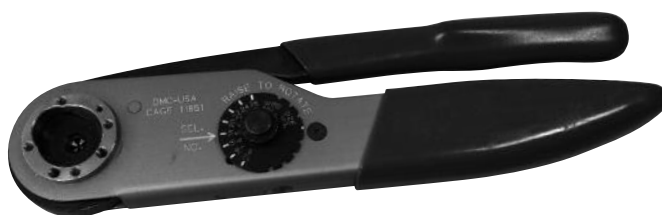

Crimp barrel accommodation for crimping HP contact		
Hand crimp tool reference	Positioner	HP contact serie
DANIELS AF8	C16460	30
DANIELS AF8	C16461	22



Tools

DANIELS HX3 TOOL P/N 13858

Tools reference	Reference Nicomatic
DANIELS HX3 only	I3858
DANIELS HX3 & C13847	C12238
DANIELS HX3 & C14680	C14770



Crimp barrel accomodation for crimping coaxial contact shield		
Hand crimp tool reference	Dies	Hexagonal imprint
DANIELS HX3	C13847	Hex. 1,9 / Hex. 2,4 / Hex. 2,8
DANIELS HX3	C14680	Hex. 3,25 / Hex. 4

CRIMP DIE C13847 FOR DANIELS HX3 TOOL (HF CONTACT)

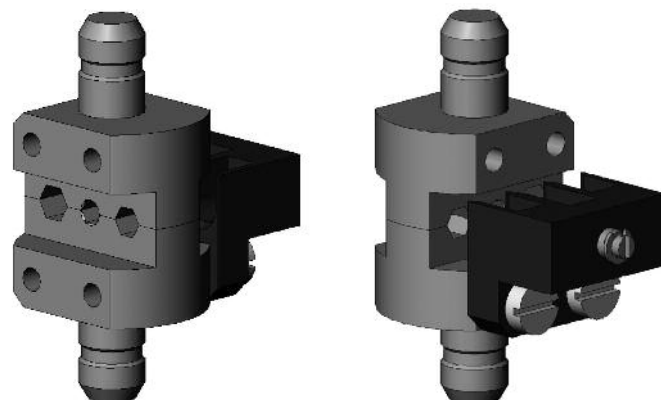
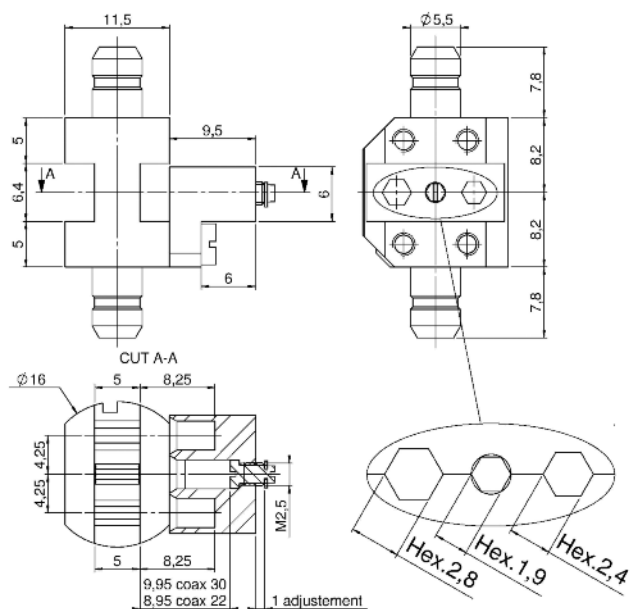

CRIMP DIE C14680 FOR DANIELS HX3 TOOL (HF CONTACT)

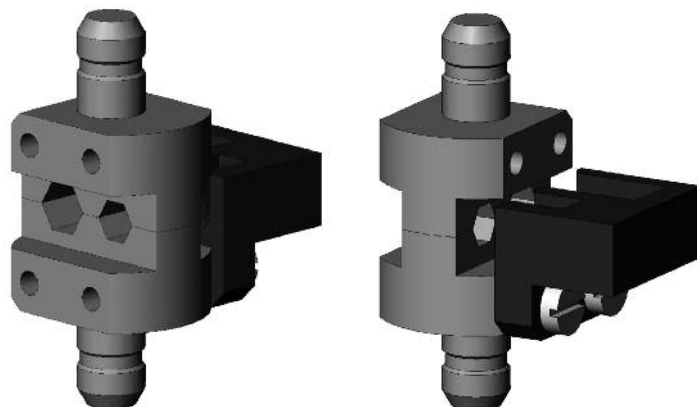
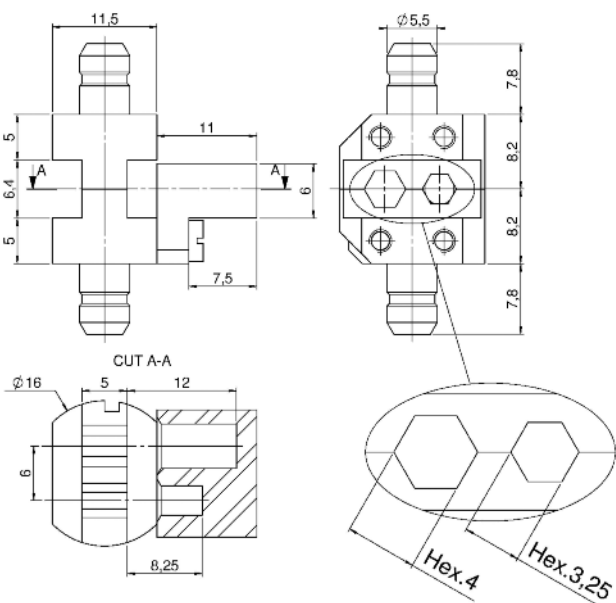

Tools

LF CONTACTS INSERTION & WITHDRAWAL TOOL P/N C12935

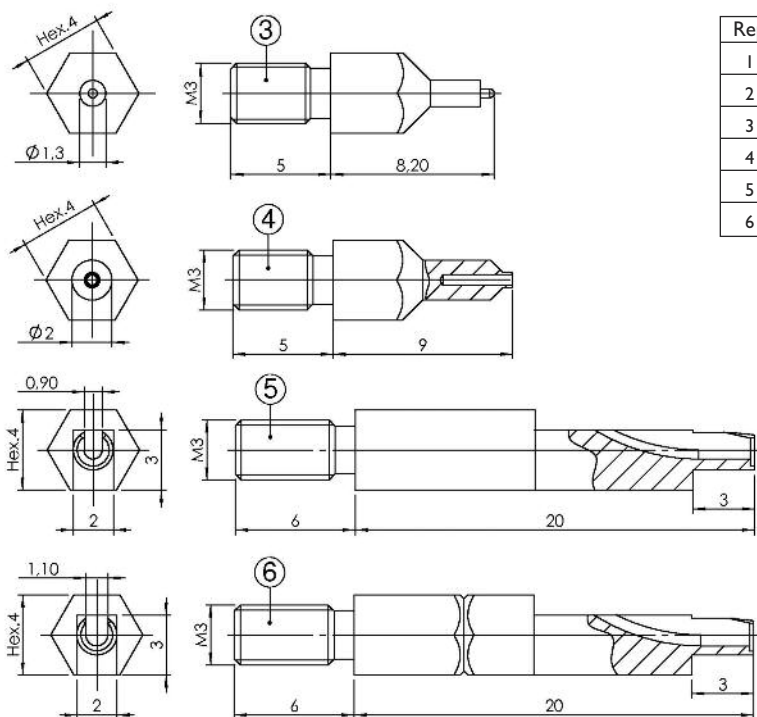

Rep	Reference	Assembly C12935
1	13241	Body
2	13240	Plug
3	13170	Female contact extraction tip
4	13242	Male contact extraction tip
5	13171	24-28 AWG insertion tip
6	13712	22 AWG insertion tip

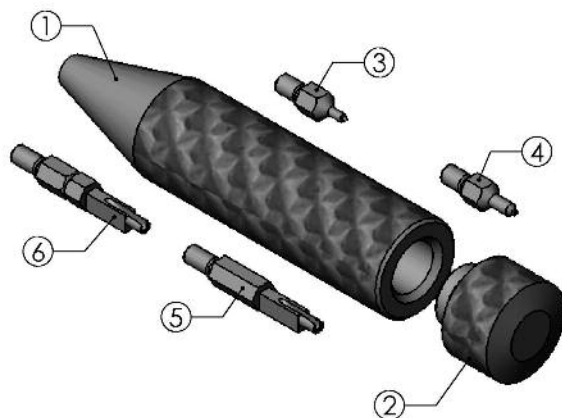

HF / HP SERIES 22 CONTACTS REMOVAL P/N C13997

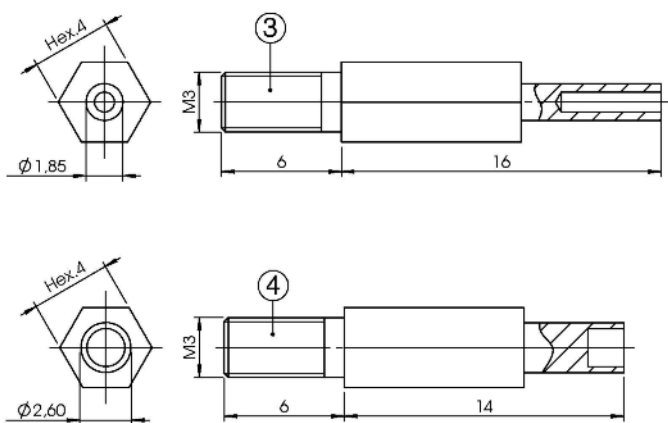

Rep	Reference	Assembly C13997
1	13241	Body
2	13240	Plug
3	13995	Female contact extraction tip
4	13996	Male contact extraction tip
5	16139	Male & female contact insertion tool

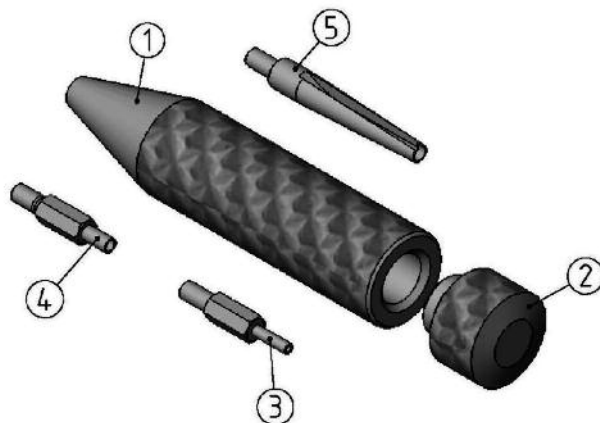

HF / HP SERIES 30 CONTACTS REMOVAL P/N 12368

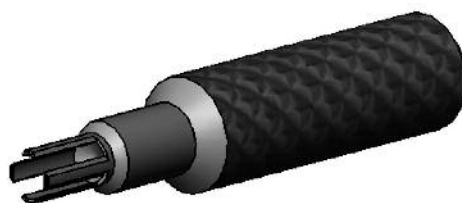
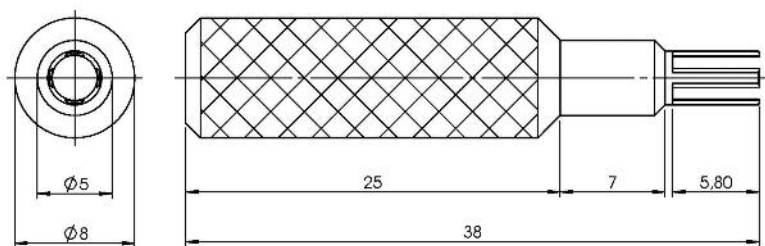

Tools

LATCH SEPARATION TOOL P/N C14790

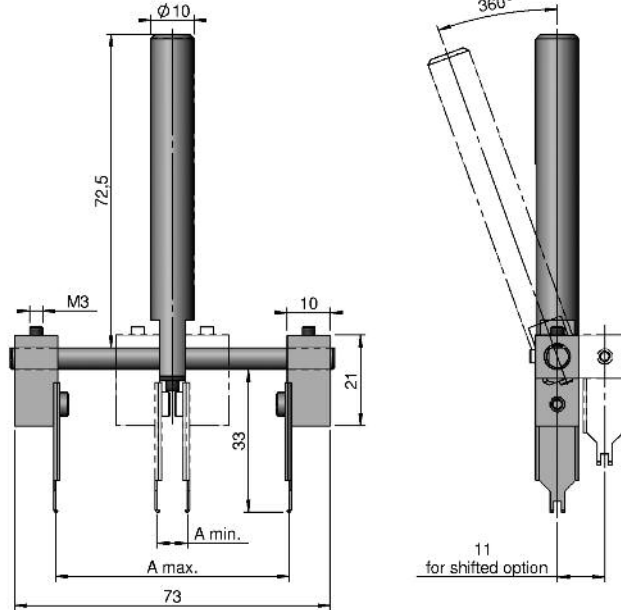
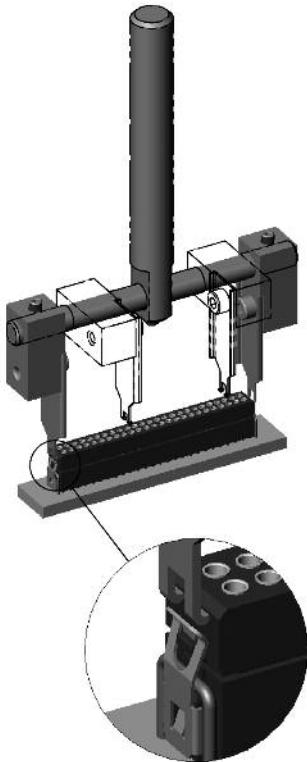

Series	A max.		A min.	
	A max.	LF contacts	A min.	LF contacts
CMM 100	53	25	7	2
CMM 200	53	50	7	4

SCREWDRIVER P/N C14743 FOR NUT P/N 12685

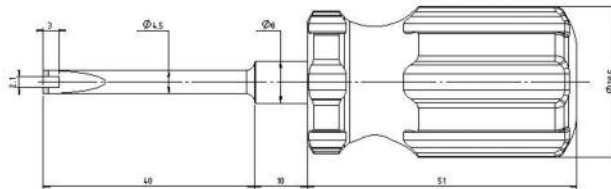
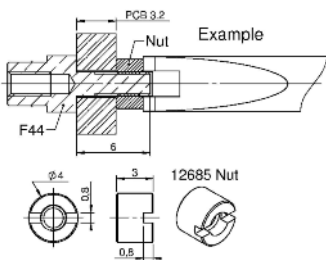

Optional: dynamometric screwdriver specifically designed for low torques (includes bits & adjusting key).

MOUNTING OF C14772 BACK CAPS

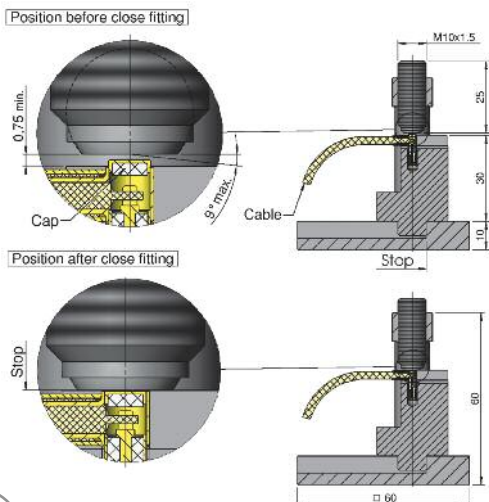

SUCOFLEX SOLDER TOOL P/N C14777

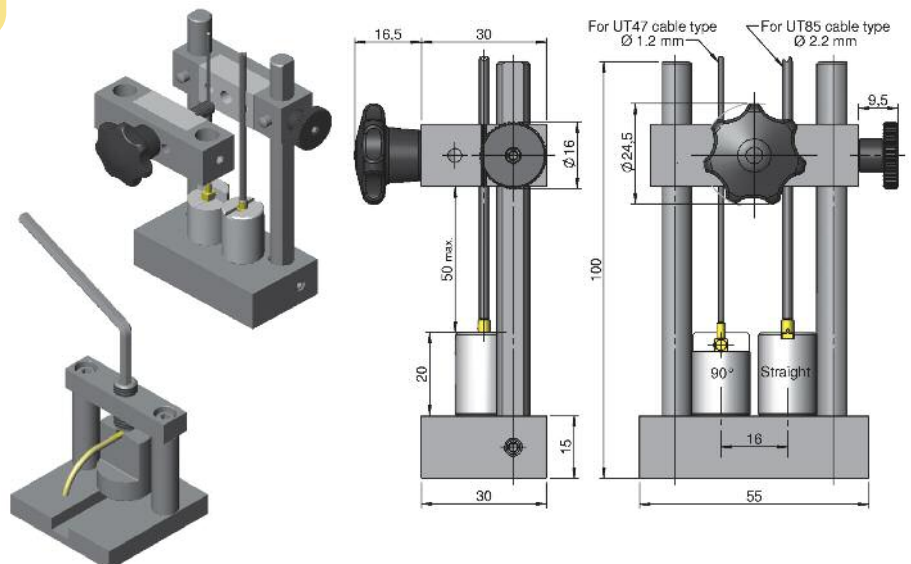

Hex. 5mm Tool not delivered

Accessories

STRAIGHT COVER FOR CMM SERIES 220 (male & female) P/N CMM-C2-XX (other upon request)

Material : high temp. thermoplastic (-55°C to +200°C)

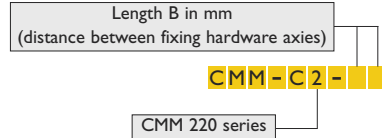
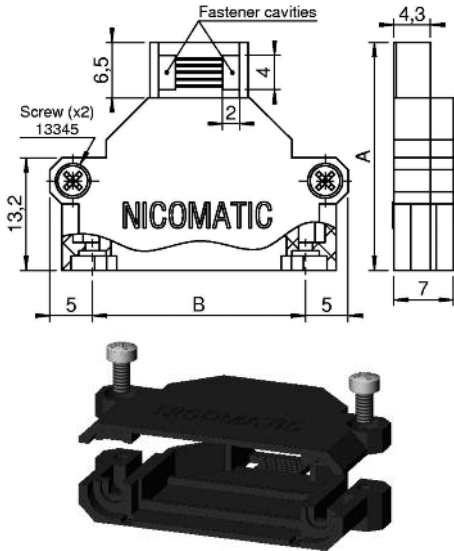

Reference	Length B	Length A	Screw (x2)
CMM-C2-11	11 mm	23,7 mm	Included
CMM-C2-15	15 mm	23,7 mm	
CMM-C2-17	17 mm	17,2 mm	
CMM-C2-25	25 mm	26,7 mm	
CMM-C2-27	27 mm	26,7 mm	
CMM-C2-31	31 mm	29,7 mm	
CMM-C2-39	39 mm	29,7 mm	
CMM-C2-45	45 mm	33,7 mm	
CMM-C2-47	47 mm	33,7 mm	
CMM-C2-49	49 mm	33,7 mm	
CMM-C2-53	53 mm	33,7 mm	
CMM-C2-55	55 mm	33,7 mm	

Note: F28 and M18 fixings are not included with the cover

45° COVER FOR CMM SERIES 220 (male & female) P/N CMM-C2-XX-45 (upon request)

Material : high temp. thermoplastic (-55°C to +200°C)

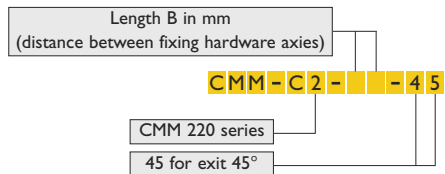
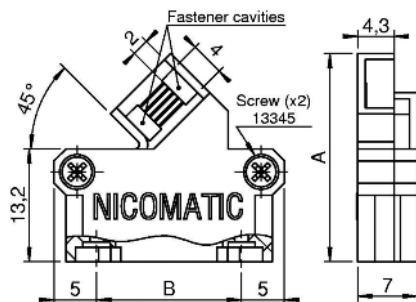

Reference	Length B	Length A	Screw (x2)
CMM-C2-17-45	17 mm	24,4 mm	Included

CMM220 male F28 fixing not included with cover

CMM220 female M18 fixing not included with cover

90° COVER FOR CMM SERIES 220 (male & female) P/N CMM-C2-XX-90 (upon request)

Material : high temp. thermoplastic (-55°C to +200°C)

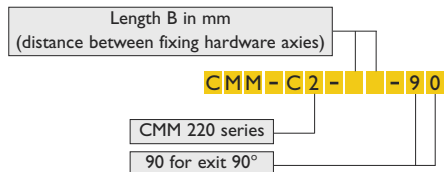
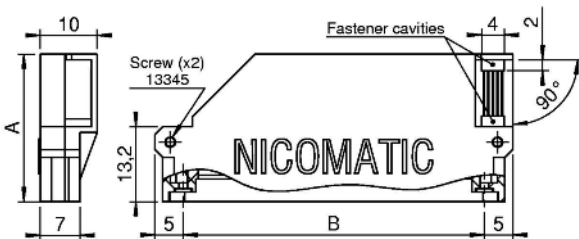

Reference	Length B	Length A	Screw (x2)
CMM-C2-53-90	53 mm	26 mm	Included

CMM220 male F28 fixing not included with cover

CMM220 female M18 fixing not included with cover

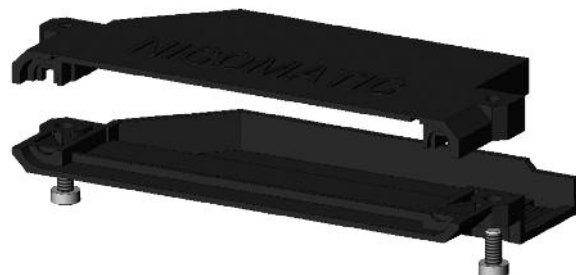

Note: Aluminum covers are available upon request. Contact us

Accessories

COVERS STRAIGHT FOR CMM SERIES 320 & 340 (male & female) P/N CMM-C3-XX.X

Material : high temp. thermoplastic (-55°C to +200°C)

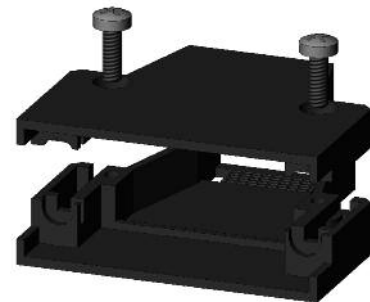
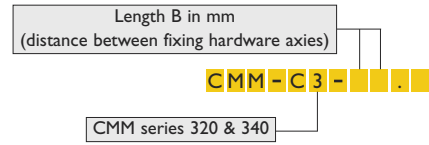
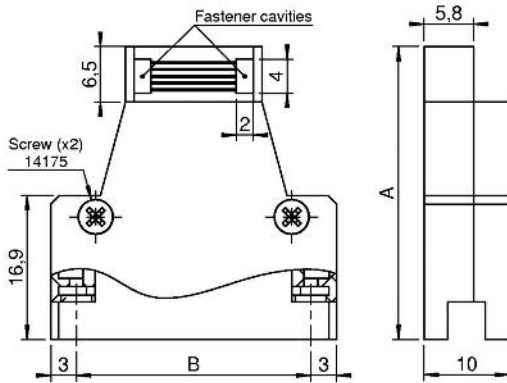

Reference	Length B	Length A	Screw (x2)
CMM-C3-27.5	27,5 mm	34,4 mm	Included
CMM-C3-45.0	45,0 mm	34,4 mm	

For CMM320/340 male & female
M45 or F57 fixing not included with cover

Other upon request

SHIELDING FOR CMM SERIES 220 (male straight on PCB) P/N 12997-XX (upon request)



XX = distance between fixing axis B

SHIELDING FOR CMM SERIES 220 (male 90° on PCB) P/N 12998-XX (upon request)

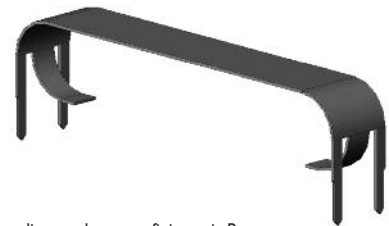
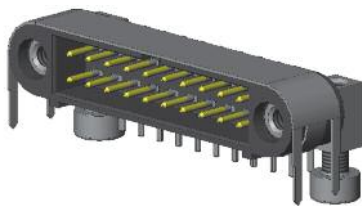

XX = distance between fixing axis B

SHIELDING FOR CMM SERIES 220 (female on cable) P/N C13024-XX (upon request)

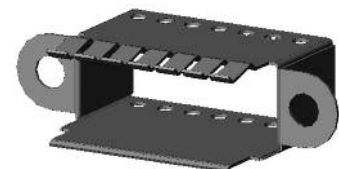
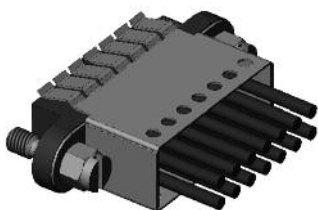

XX = distance between fixing axis B

Accessories

BACKPOTTING SHAPE FOR CMM SERIES 200 (female) P/N 14501-XX

Material : thermoplastic 100°C max.

Reference	Length B
14501-07	min. 7 mm
14501-09	9 mm
14501-11	11 mm
14501-13	13 mm
14501-15	15 mm
14501-17	17 mm
14501-19	19 mm
14501-21	21 mm
14501-23	23 mm
14501-25	25 mm
14501-27	27 mm
14501-29	29 mm
14501-31	31 mm
14501-33	33 mm
14501-35	35 mm
14501-37	37 mm
14501-39	39 mm
14501-41	41 mm
14501-43	43 mm
14501-45	45 mm
14501-47	47 mm
14501-49	49 mm
14501-51	51 mm
14501-53	max. 53 mm

14501-xx (xx = length B in mm)

Example with B=23mm : Ref = 14501-23

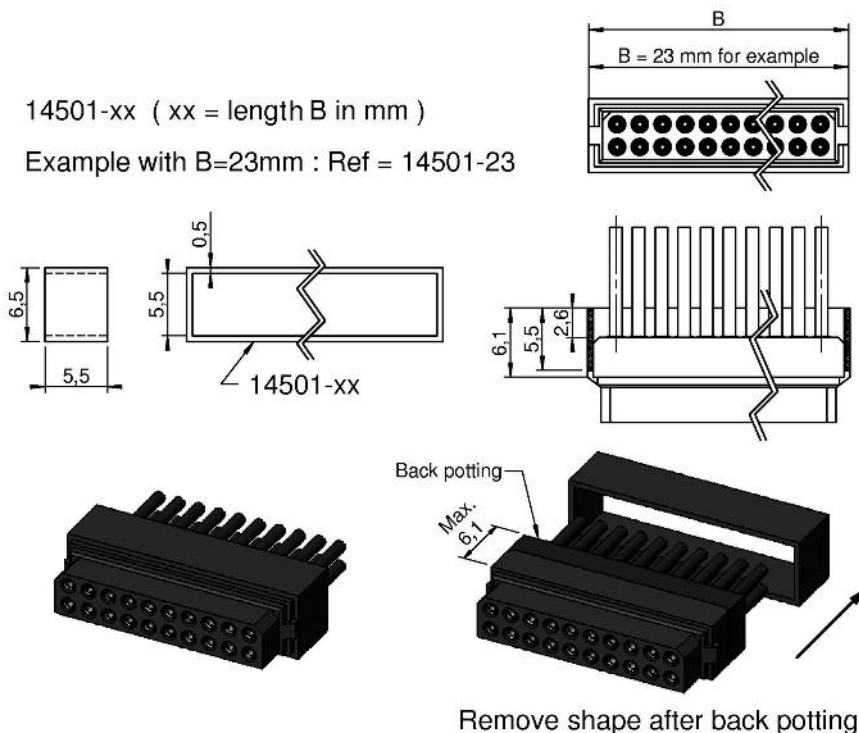

Remove shape after back potting

BACKPOTTING SHAPE FOR CMM SERIES 220 (male & female) P/N 14143-XX

Material : thermoplastic 100°C max.

Reference	Length B
14143-09	min. 9 mm
14143-11	11 mm
14143-13	13 mm
14143-15	15 mm
14143-17	17 mm
14143-19	19 mm
14143-21	21 mm
14143-23	23 mm
14143-25	25 mm
14143-27	27 mm
14143-29	29 mm
14143-31	31 mm
14143-33	33 mm
14143-35	35 mm
14143-37	37 mm
14143-39	39 mm
14143-41	41 mm
14143-43	43 mm
14143-45	45 mm
14143-47	47 mm
14143-49	49 mm
14143-51	51 mm
14143-53	53 mm
14143-55	55 mm
14143-57	57 mm
14143-59	59 mm
14143-61	61 mm
14143-63	63 mm
14143-65	max. 65 mm

14143-xx (xx = length B in mm)

Example with B=25mm : Ref = 14143-25

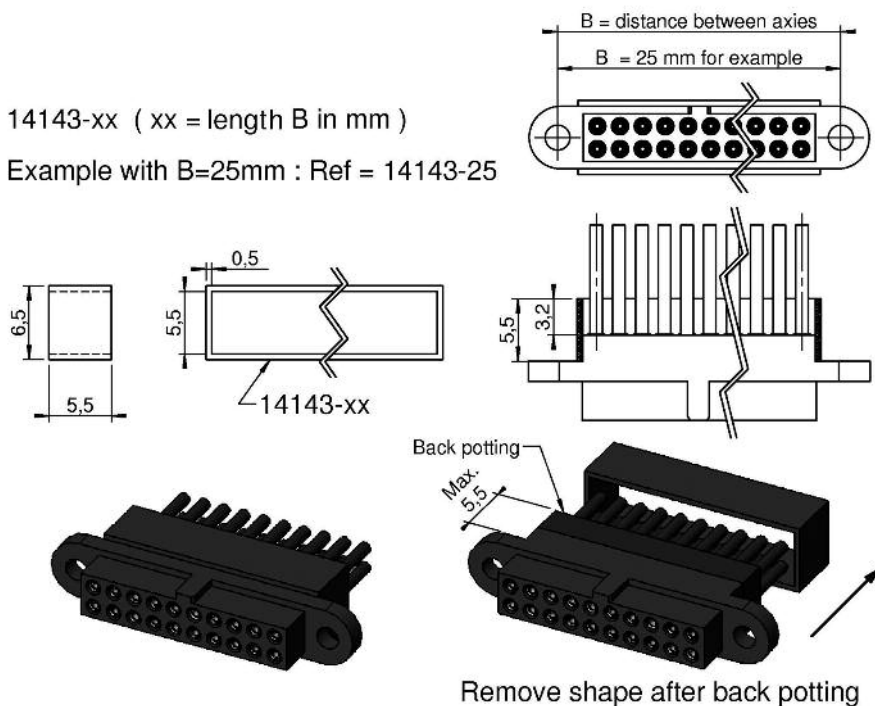

Remove shape after back potting

Note: Special housing with integrated backpotting available upon request.

Accessories

CONTACTS ALIGNMENT PLATE P/N 14601-120

Material : high temperature thermoplastic (-55°C to +200°C)

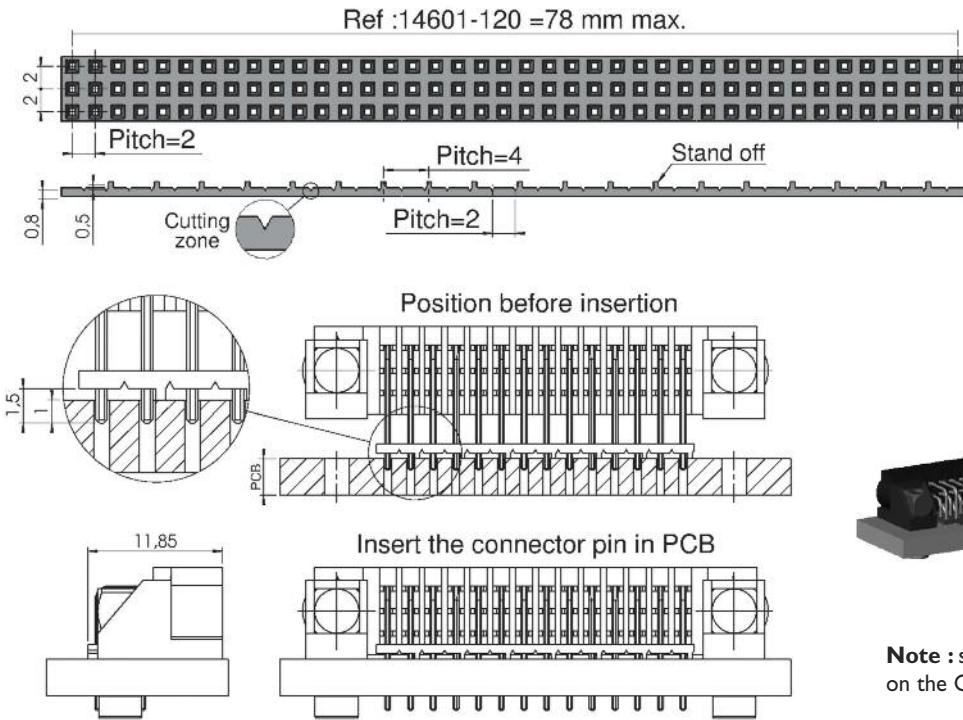

Divisible

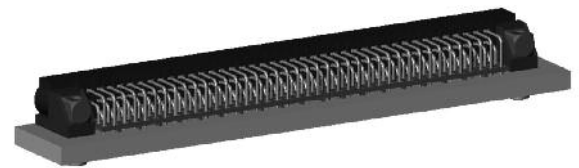

Note : systematically delivered and mounted on the CMM 320 series "right angle" (V and VL types)

SILICON INTERFACIAL SEAL (for male connector except S-C types)

LF 220 series P/N 14599-54 = 52 mm max.

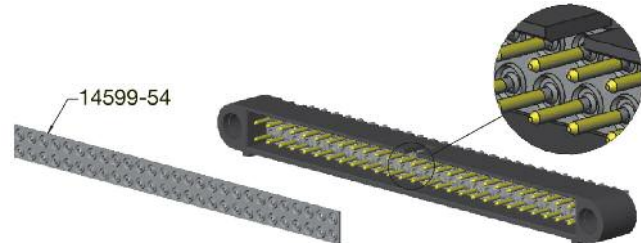
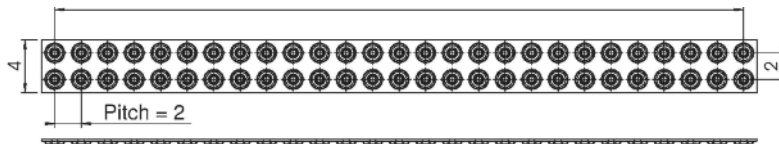

LF 320 series P/N 14980-120 = 78 mm max.

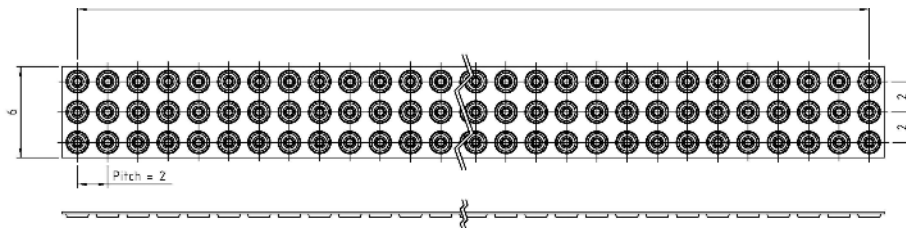

Special contacts 220 series P/N 16053-15 = 60,2 mm max.

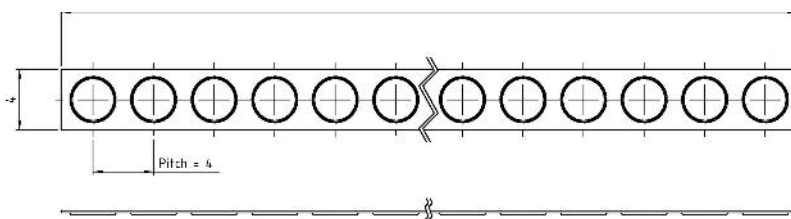

Mix-layout on request

Accessories

COAX CABLE CRIMP TERMINATION (straight for cables Ø 2 and Ø 2,7)

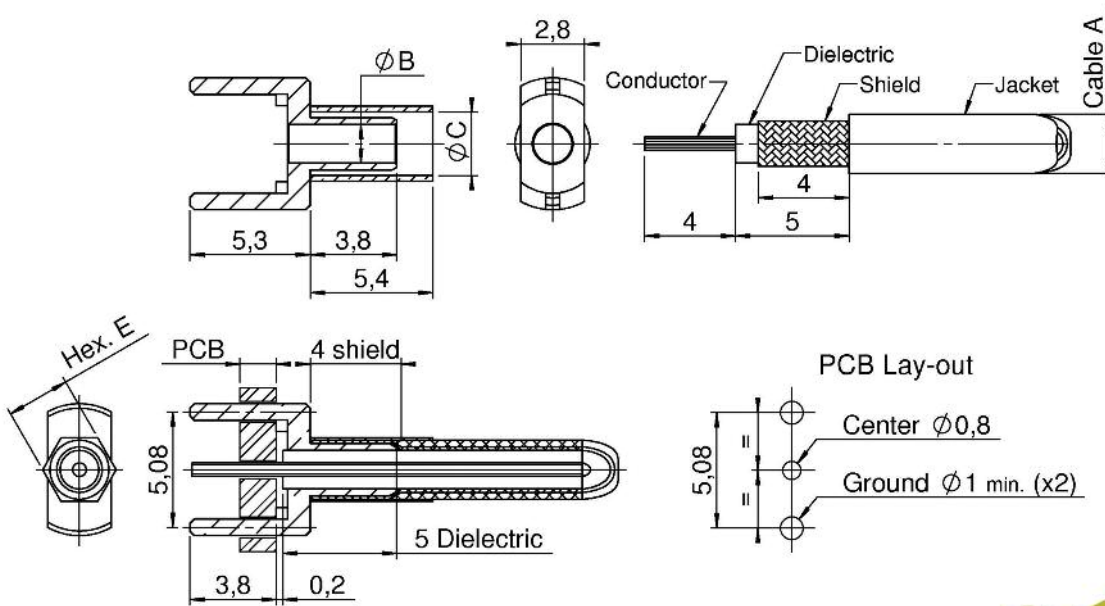

	CI4759	CI4760
Cable A	Ø 2	Ø 2,7
Ø B	1 mm	1,7 mm
Ø C	2,2 mm	2,8 mm
Hex. E	2,4 on flat	2,8 on flat

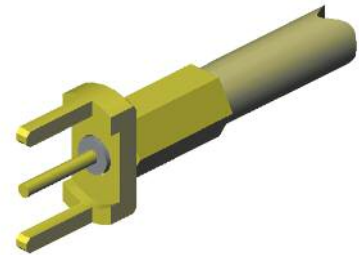

COAX CABLE CRIMP TERMINATION (90° for cables Ø 2 and Ø 2,7)

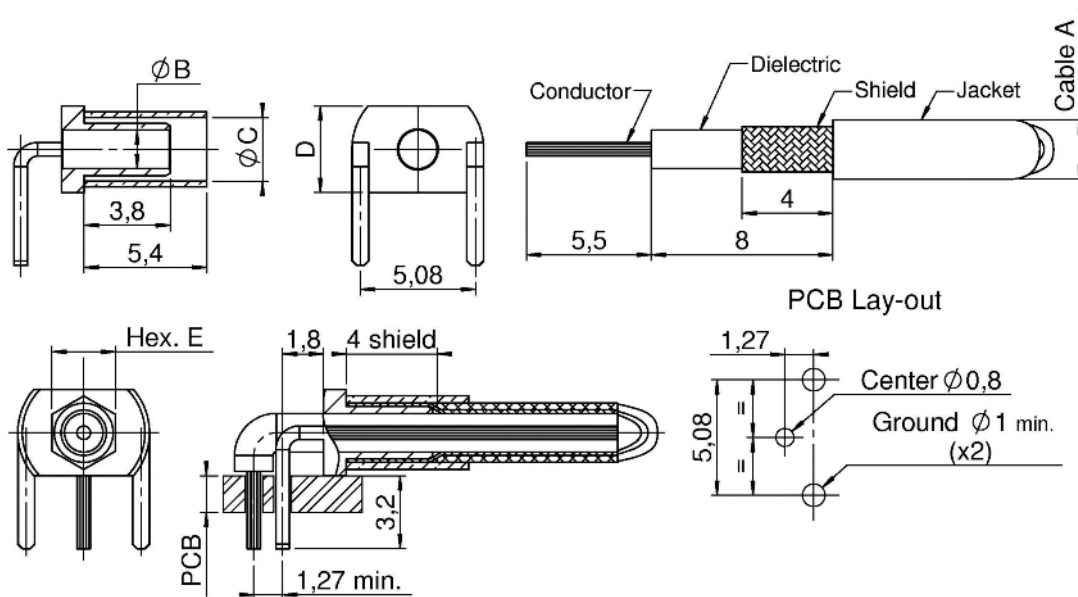

	CI4761	CI4762
Cable A	Ø 2	Ø 2,7
Ø B	1 mm	1,7 mm
Ø C	2,2 mm	2,8 mm
Length D	3,4 mm	3,8 mm
Hex. E	2,4 on flat	2,8 on flat

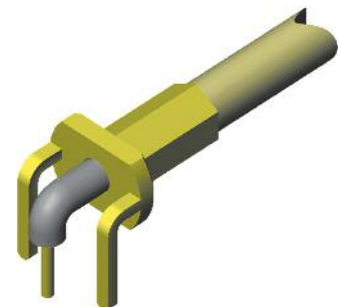

Accessories

COAX CABLE CRIMP TERMINATION P/N C13313 for RG 178 and P/N C14765 for RG 178 DS

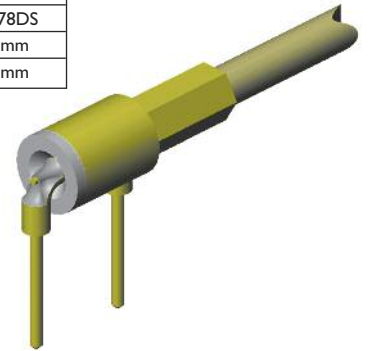
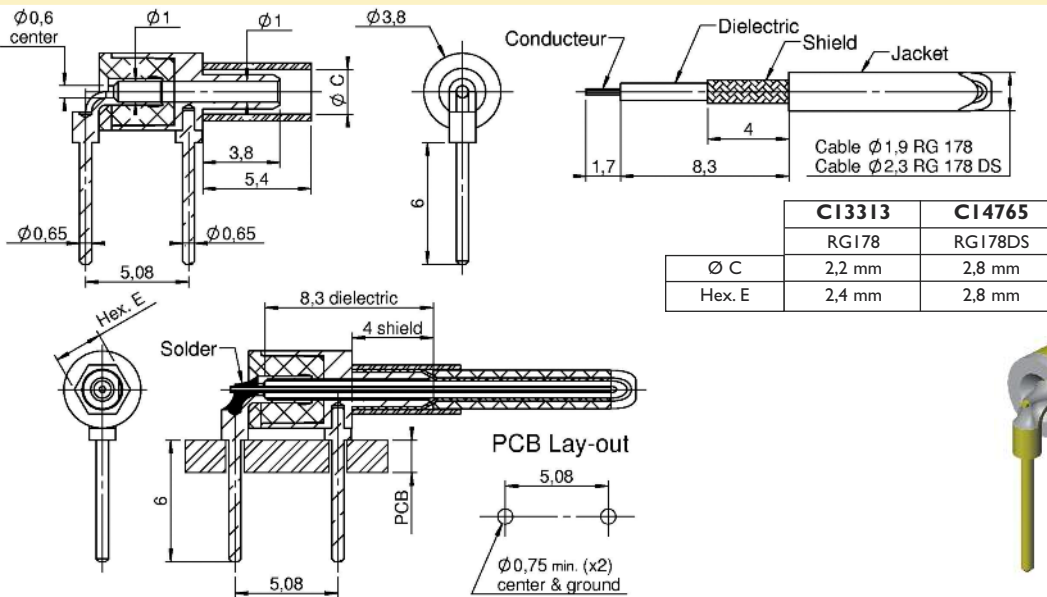

COAX CABLE CRIMP TERMINATION P/N C12780 for cables RG 316

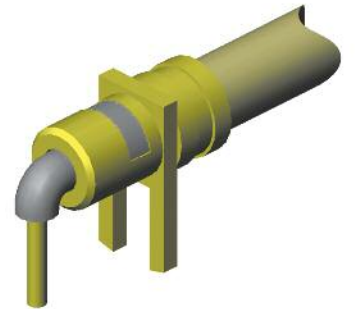
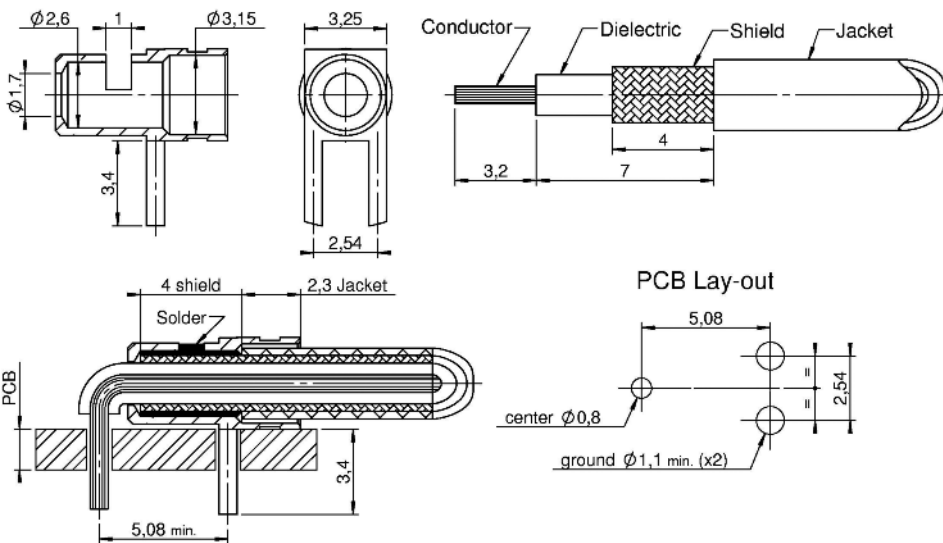

CRIMP GAUGE REDUCER for awg 30-32 for LF contacts P/N 12922 & 14142

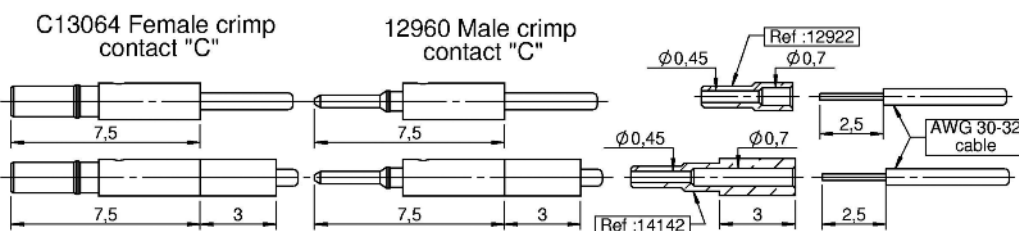

Gender	Contact "C"	Reducer	Tool	Positioner	Position 1st crimp	Position 2nd crimp
Male	12960	12922	MH800	K1692	Contact + reducer + cable position "4"	
Female	C13064-P					
Male	12960	14142	MH800	K1692	Reducer + cable position "8"	(Reducer & cable) + contact position "4"
Female	C13064-P					

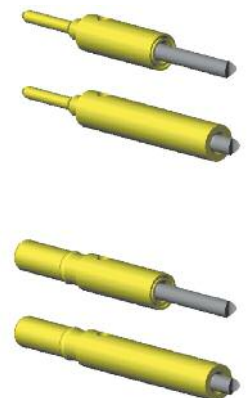

Cable instructions (ICLF01)

Diameter X	
Reference	X
12969	0.7
16035	
C12468	
C16026	0.9
12960	
C13064-P	

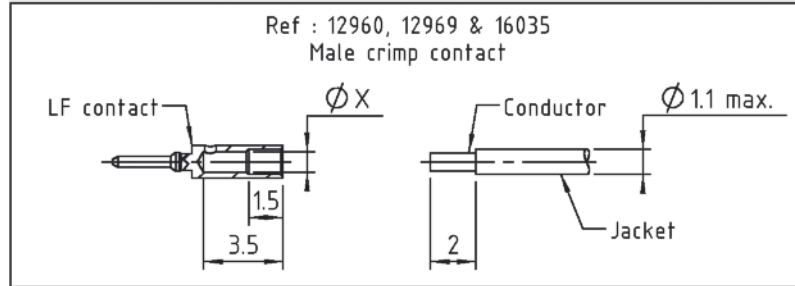
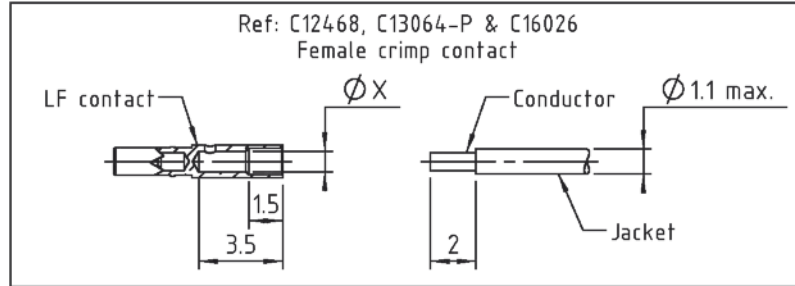

Crimp barrel accommodation					
Contact		Wire size (AWG)	Tool		
Reference	Type		Hand crimp tool reference	Positioner	Crimp tool setting
12960	Male C	22	DANIELS MH800	K1692	6
12969	Male S	24			7
16035					7
12969	Male S	26 & 28			6
16035					6
C13064-P	Female C	22			6
C12468	Female S	24			7
C16026					7
C12468	Female S	26 & 28			6
C16026					6

1 - Set the Hand crimp tool according to Crimp barrel accommodation table above

- 1.1 - Select the crimp tool setting with the selector knob.
- 1.2 - Put the Positioner K1692 in the positioner guide.

Put the positionner K1692 in the positionner guide

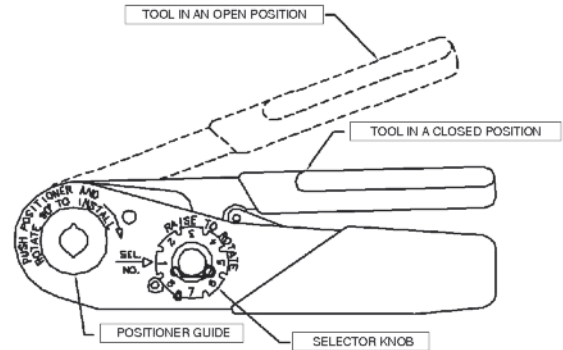

2 - Check the wire stripping

- 2.1 - Insert the Wire in the contact
- 2.2 - The conductor must be visible through the inspection window of the contact

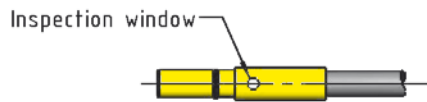

3 - Insert the contact and Wire assembly in the crimp guide of the hand crimp tool

- 3.1 - In the crimp guide, the contact and Wire assembly must be in the end stop position
- 3.2 - During the crimping, keep the wire in position
- 3.3 - Just one crimping operation is allowed per contact and wire assembly

4 - Visually check the crimping

- 4.1 - The crimping must not deform the inspection window
- 4.2 - The contact must not have visible fractures or cracks
- 4.3 - The contact barrel must not be deformed or bent

5 - Check the contact is firmly crimped, by pulling gently

- 5.1 - For that purpose two (2) fingers are enough : pinch the wire and pull smoothly along the axis of the crimped contact.

Cable instructions

HF CONTACTS						CONNECTION MODE								
Supplier	P/N	Ø Cable	Series	Gender	Ref. contact	Central contact	Shield	Impedance						
Nexans (Axon *)	50VMTX (SM 50 *)	1,2 mm	HF30	Male	30-1312-ZS-01 (30-1312-ZS-02 *)	Solder	Crimped Hex. 1,9 mm	50 Ohm						
					30-1412-ZS									
				Female	30-2312-ZS-01 (30-2312-ZS-02 *)									
				30-2412-ZS										
			HF22	Male	22-1312-ZS-01 (22-1312-ZS-02 *)									
				Female	22-2312-ZS-01 (22-2312-ZS-02 *)									
	75VMTX (SM 75 *)	1,2 mm		HF30	Male	30-1312-ZS-75-01 (30-1312-ZS-75-02 *)	Solder	Crimped Hex. 1,9 mm	75 Ohm					
					30-1412-ZS-75									
			Female		30-2312-ZS-75-01 (30-2312-ZS-75-02 *)									
				30-2412-ZS-75										
			HF22	Male	22-1312-ZS-75-01 (22-1312-ZS-75-02 *)									
				Female	22-2312-ZS-75-01 (22-2312-ZS-75-02 *)									
Axon RG 178 DT	P500955	2,3 mm		HF30	Male	30-1320-DS 30-1420-DS	On choice Solder	Crimped Hex. 2,8 mm	50 Ohm					
			Female	30-2320-DS 30-2420-DS	On choice Solder									
Axon PTFE Cellular	P 812817	2,3 mm	HF30	Male	30-1324-DS 30-1424-DS	On choice Solder	Crimped Hex. 2,8 mm	50 Ohm						
				Female	30-2324-DS 30-2424-DS	On choice Solder								
	P 804298 B	2,4 mm	HF30	Male	30-1324-DS-75 30-1424-DS-75	On choice Solder	Crimped Hex. 2,8 mm	75 Ohm						
				Female	30-2324-DS-75 30-2424-DS-75	On choice Solder								
Axon RG 316 DT	P0530912	2,7 mm	HF30	Male	30-1326-DS 30-1426-DS	On choice Solder	Crimped Hex. 3,25 mm	50 Ohm						
				Female	30-2326-DS 30-2426-DS	On choice Solder								
				Axon RG 179 DT	P530268	3 mm			HF30	Male	30-1326-DS-75 30-1426-DS-75	On choice Solder	Crimped Hex. 3,25 mm	75 Ohm
										Female	30-2326-DS-75 30-2426-DS-75	On choice Solder		

DT = DS (Double Shield)

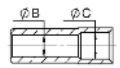
	ØB	ØC	Sleeve
P/N terminal -01 for 50VMTX cable type	1 mm	1,25 mm	
P/N terminal -02 for SM 50 cable type	0,85 mm	1,15 mm	

Cable instructions

	NORMES			HF CONTACTS			CONNECTION MODE		
	MIL-C-17	NF C93-550	Ø Cable	Series	Gender	Ref. contact	Central contact	Shield	Impedance
COAX CABLE	RG 178	KX 21 A	2 mm	HF30	Male	30-1320-SS	Crimped	Crimped Hex. 2,4 mm	50 Ohm
						30-1320-ZS	Solder		
						30-1420-ZS	Solder		
				HF22	Female	30-2320-SS	Crimped		
						30-2320-ZS	Solder		
						30-2420-ZS	Solder		
	RG 316	KX 22 A	2,7 mm	HF30	Male	30-1326-SS	Crimped	Crimped Hex. 2,8 mm	50 Ohm
						30-1326-ZS	Solder		
					Female	30-1426-ZS	Crimped		
						30-2326-SS	Crimped		
	RG 174	KX 3 B	2,7 mm	HF30	Male	30-1326-SS	Crimped	Crimped Hex. 2,8 mm	50 Ohm
						30-1326-ZS	Solder		
Female					30-1426-ZS	Crimped			
					30-2326-SS	Crimped			
RG 179		2,7 mm	HF30	Male	30-1326-SS-75	Crimped	Crimped Hex. 2,8 mm	75 Ohm	
					30-1326-ZS-75	Solder			
					30-1426-ZS-75	Solder			
				Female	30-2326-SS-75	Crimped			
					30-2326-ZS-75	Solder			
					30-2426-ZS-75	Solder			

	HF CONTACTS					CONNECTION MODE			
	Supplier	P/N	Ø Cable	Series	Gender	Ref. contact HF	Central contact	Shield	Impedance
SEMI-RIGID		UT47	1,2 mm	HF30	Male	30-1347-ZZ	Solder	Solder	50 Ohm
						30-1447-ZZ			
(Axon *)	UT85 (QFX 86 SPCW *)	2,2 mm	HF30	Male	30-1385-ZZ	Solder	Solder	50 Ohm	
					30-1485-ZZ				
				Female	30-2385-ZZ				
					30-2485-ZZ				

Cable instructions (IC22HF01)

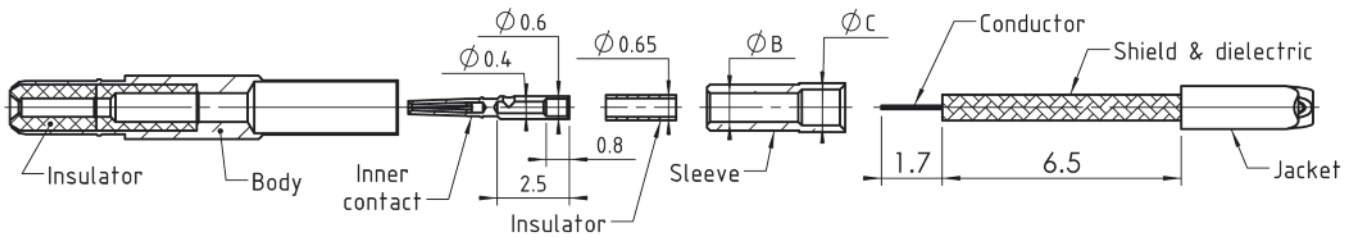

- 1/ 1.1 - Thread the sleeve until stop onto the cable.
 1.2 - Place the shield on the sleeve.

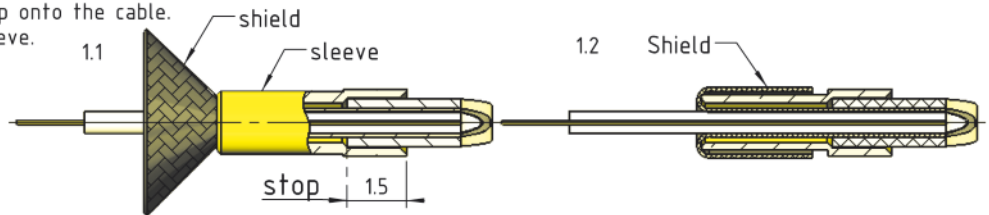

- 2/ - Thread the insulator.
 - Solder the inner contact on the conductor.

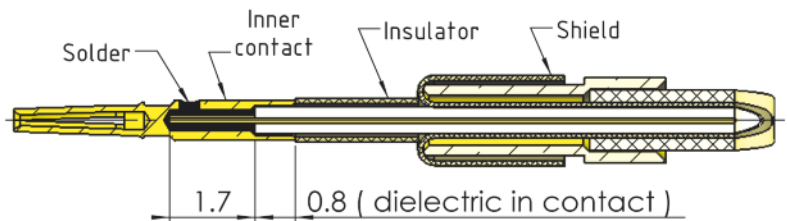

- 3/ - Thread to the body.
 - Beware that the inner contact's hook goes entirely through the body's insulator

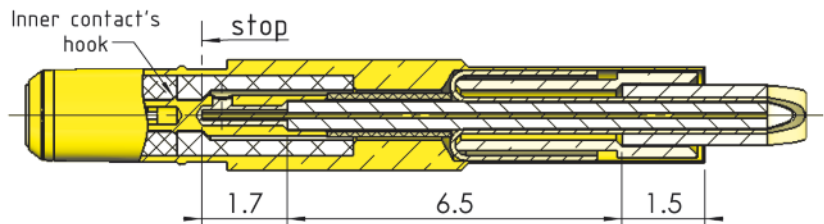

- 4/ CRIMP :
 - Tool : DANIELS HX3
 - Die : C13847
 - Position : 8.95 coax 22
 - Hexagone : 1.9mm / plats

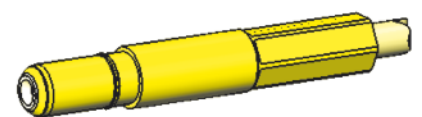
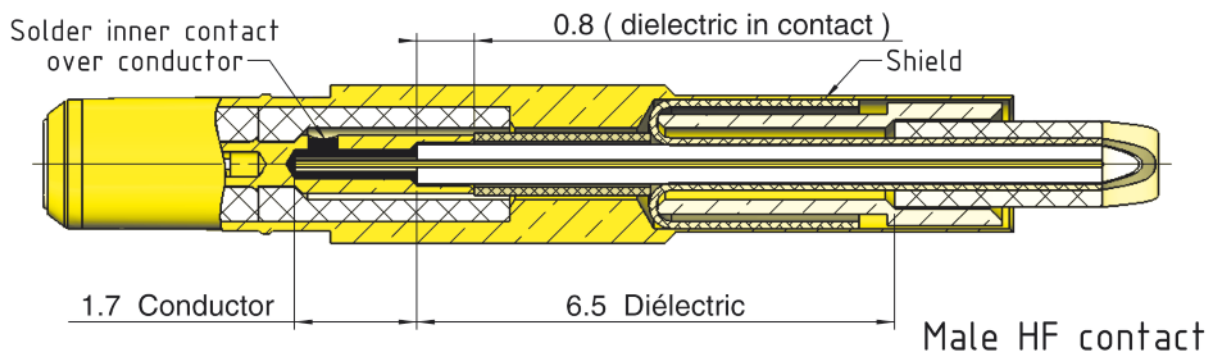
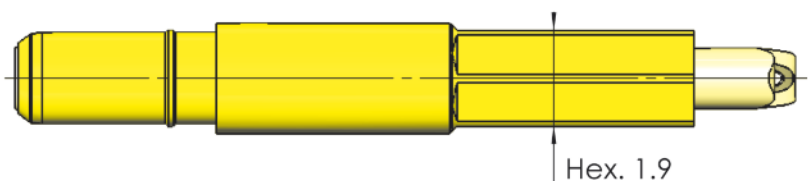

Cable instructions (IC22HF02)

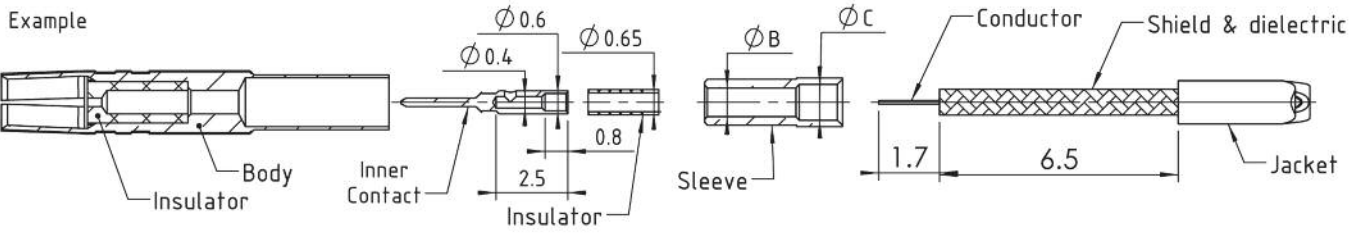

- 1/ 1.1 - Thread the sleeve until stop onto the cable.
 1.2 - Place the shield on the sleeve.

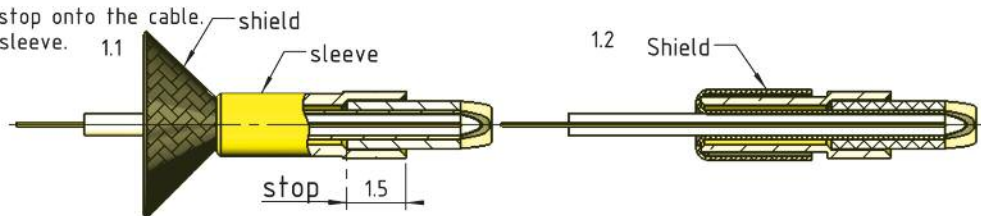

- 2/ - Thread the insulator.
 - Solder the inner contact on the conductor.

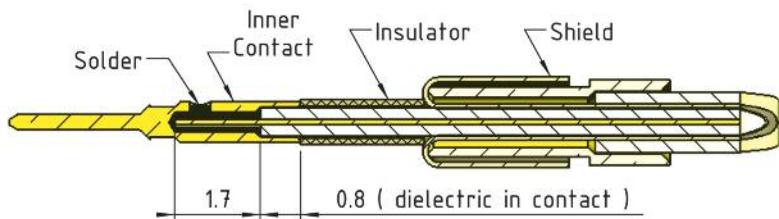

- 3/ - Put the contact body in the tool C16447.
 - Thread to the body.
 - Beware that the inner contact's hook goes entirely through the body's insulator.

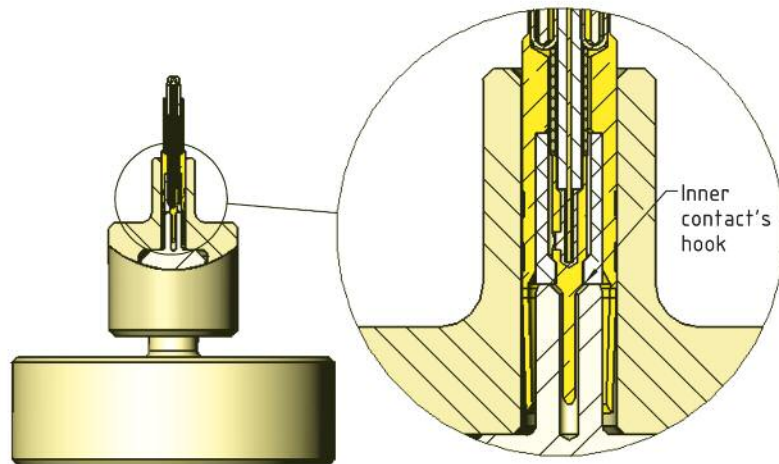

- 4/ CRIMP :
- Tool : DANIELS HX3
 - Die : C13847
 - Position : 8.95 coax 22
 - Hexagone : 1.9mm / plats
 - Position : 8.95mm

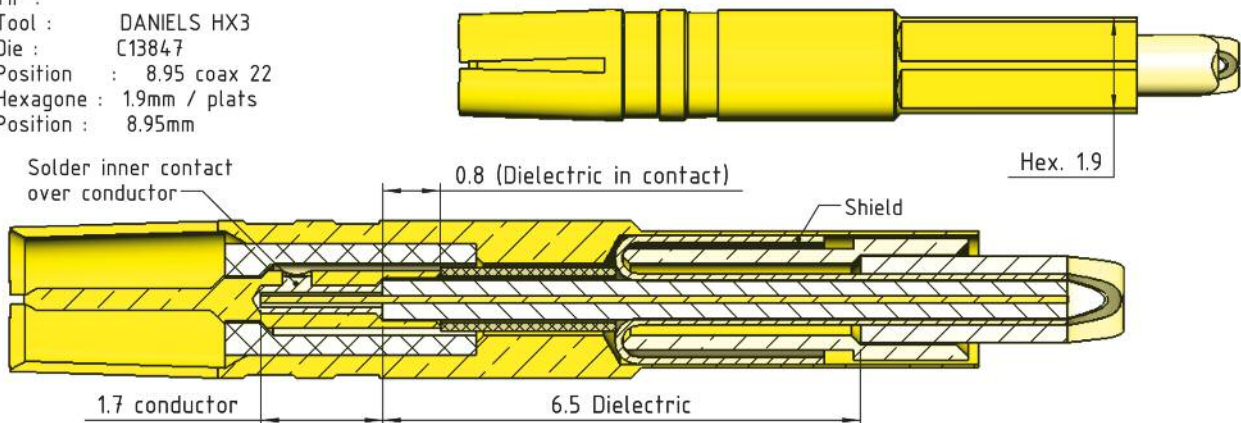

Cable instructions (IC30HF01)

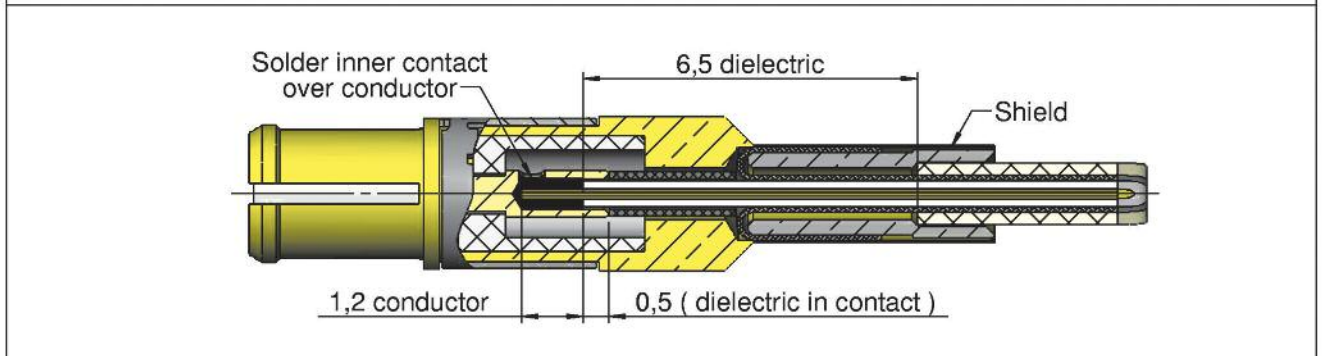
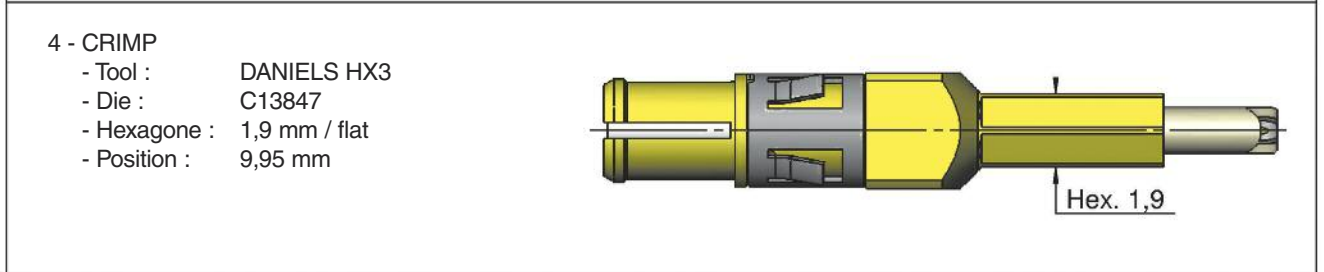
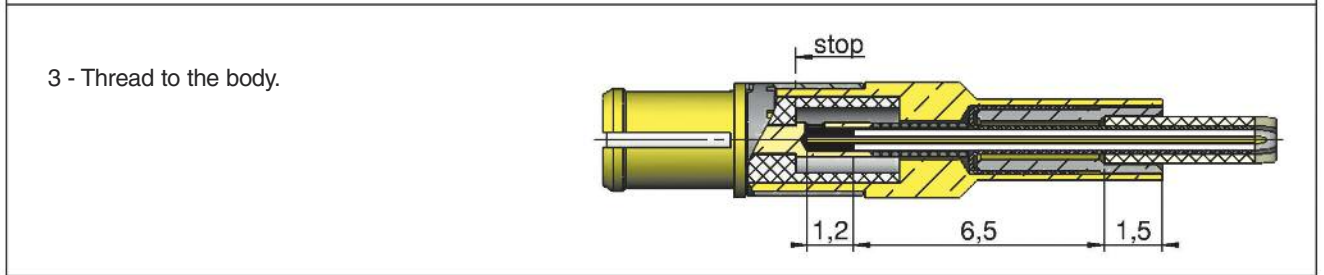
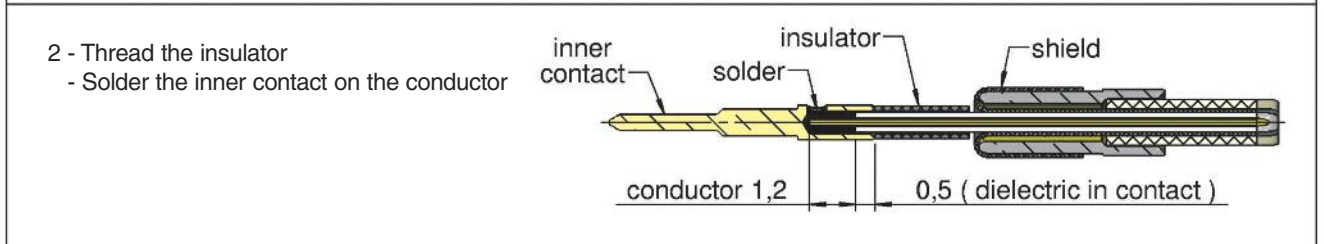
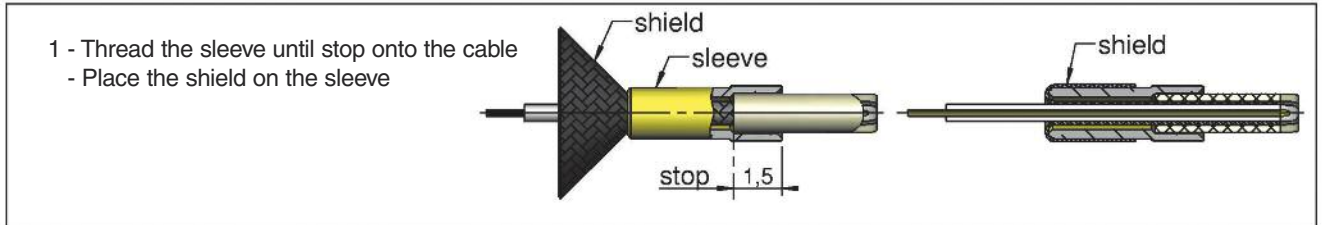
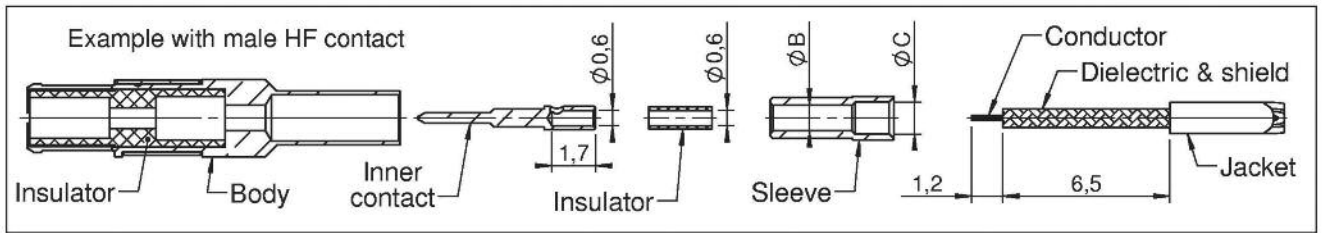

Female HF contact

	ØB	ØC	Sleeve
P/N terminal -01	1	1,25	
P/N terminal -02	0,85	1,15	

Male HF contact

Cable instructions (IC30HF02)

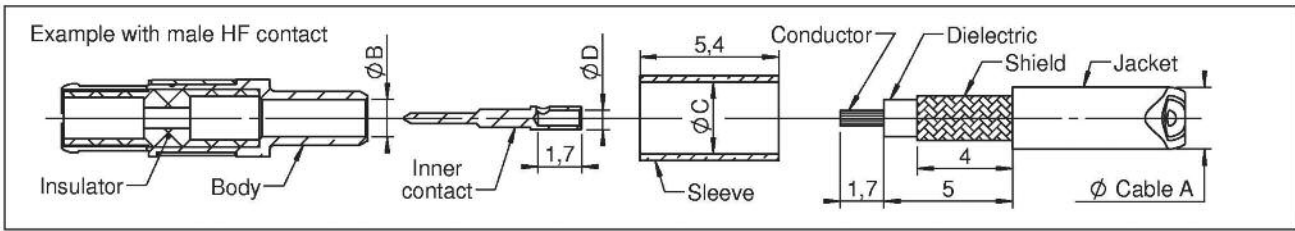

	Cable ØA	Body ØB	Sleeve ØC	Contact ØD	Central crimp DANIELS MH800		Hexagonal imprint E sleeve crimp DANIELS HX3 tool				
					Positioner K1131		Die C13847			Die C14680	
					Conductor Ø 0,3	Conductor Ø 0,5	Hex.1,9	Hex.2,4	Hex.2,8	Hex.3,25	Hex.4
30-x320-SS	2 mm	1 mm	2,2 mm	0,5 mm	Position 2 / 3	Position 3 / 4		x			
30-x320-DS	2,3 mm	1 mm	2,8 mm	0,5 mm					x		
30-x324-SS	2,4 mm	1,5 mm	2,8 mm	0,6 mm					x		
30-x326-SS	2,7 mm	1,7 mm	2,8 mm	0,6 mm					x		
30-x326-DS	3 mm	1,7 mm	3,25 mm	0,6 mm						x	

1 - Mount the inner contact on the conductor and solder or crimp.
(crimping with DANIELS MH800 positioner K1131)

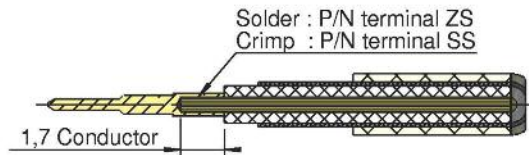

2 - Thread the sleeve onto the cable and bent the shield at 90°.

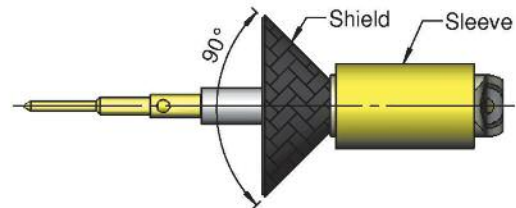

3 - Push until stop inside the body.

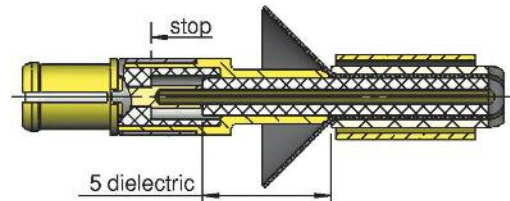

4 - Thread the sleeve until stop on the body so as to bent the shield.

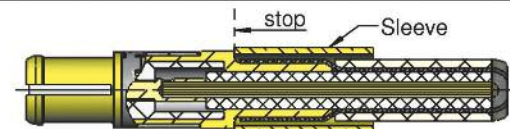

5 - Crimp the sleeve

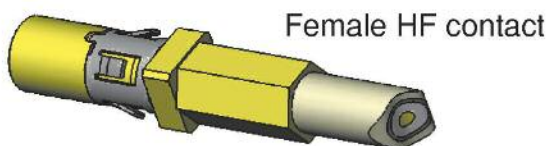
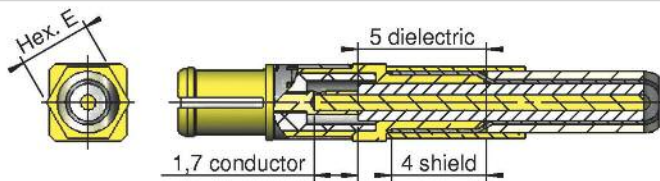

Female HF contact

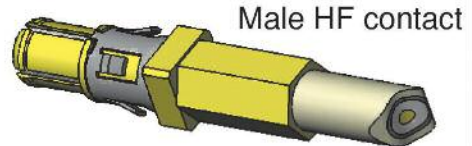

Male HF contact

Cable instructions (IC30HF03)

Example with male HF contact

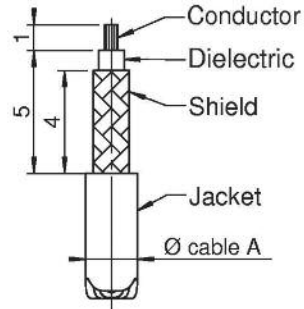
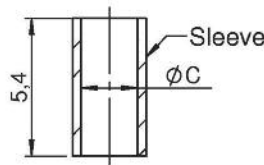
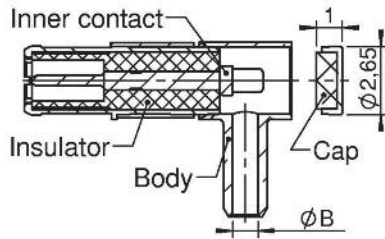

1 - Thread the sleeve on cable and bent the shield at 90°

2 - Place the inner contact until stop in the body. Insert the cable and solder the conductor onto the inner contact

3 - Thread the sleeve until stop on the body so as to bent the shield

4 - Crimp the sleeve with DANIELS HX3 tool and mount the back cap with tool P/N C14772

Hexagonal imprint E sleeve crimp DANIELS HX3 tool

	Cable ØA	Body ØB	Sleeve ØC	Contact	Die CI3847			Die CI4680	
					Hex.1,9	Hex.2,4	Hex.2,8	Hex.3,25	Hex.4
30-x412-ZS	1,2 mm	0,7 mm	1,3 mm	solder	x				
30-x420-ZS	2 mm	1 mm	2,2 mm	solder		x			
30-x420-DS	2,3 mm	1 mm	2,8 mm	solder			x		
30-x424-ZS	2,4 mm	1,5 mm	2,8 mm	solder			x		
30-x426-ZS	2,7 mm	1,7 mm	2,8 mm	solder			x		
30-x426-DS	3 mm	1,7 mm	3,25 mm	solder				x	

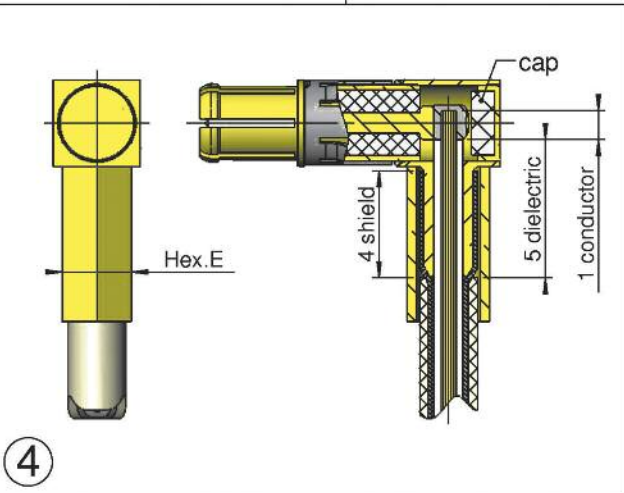
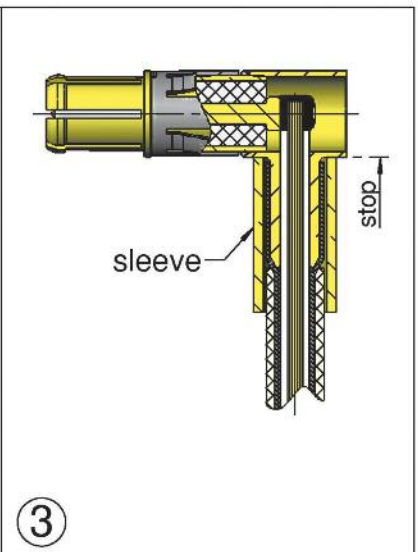
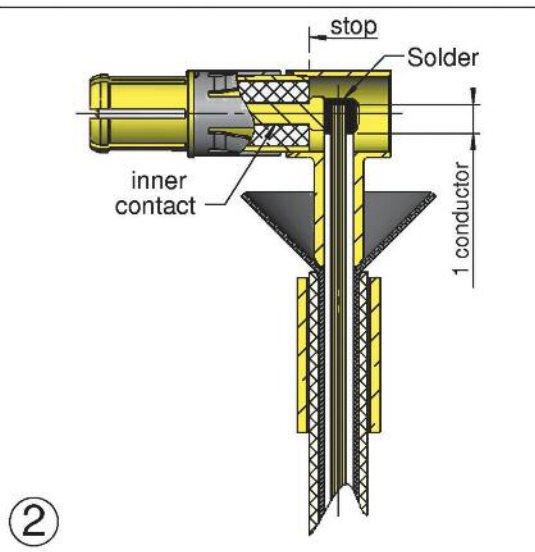
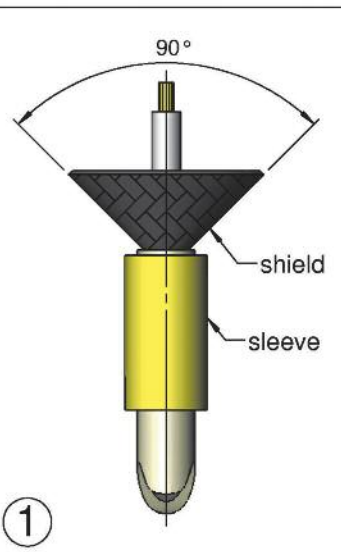

Female HF contact

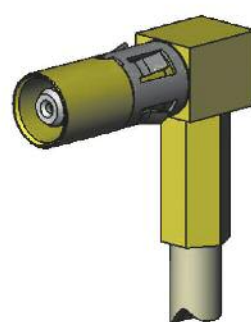

Male HF contact

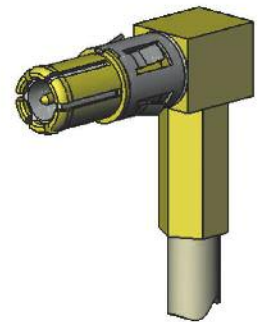

Cable instructions (IC22HP02)

Stripping

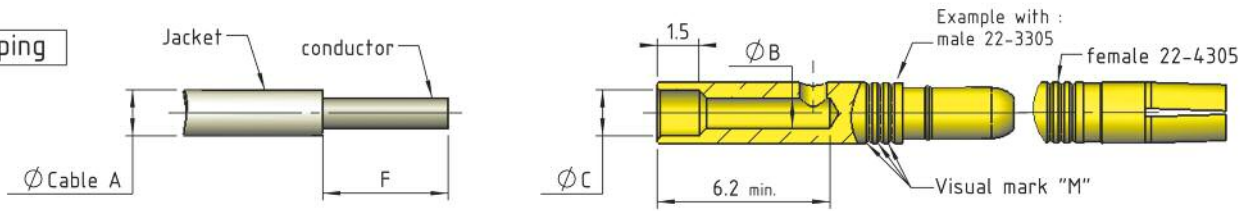

Loaded	Unloaded	Cable A			ØB	ØC	Length F conductor	M	Solder	Crimp by AF8 Tool / Positioner	Crimp tool setting - Number selector		
		AWG20	AWG18	AWG16							AWG20	AWG18	AWG16
3305	22-3305	X		NA	1.1 mm	1.65 mm	4.5 mm	x3		16459 / C16461	4		NA
3308	22-3308	NA	X	NA	1.35 mm	1.85 mm	4.5 mm	x2	OK	16459 / C16461	NA	5	NA
3310	22-3310		X		1.7 mm	NA	6 mm	x1		16459 / C16461	4	5	6

Loaded	Unloaded	Cable A			ØB	ØC	Length F conductor	M	Solder	Crimp by AF8 Tool / Positioner	Crimp tool setting - Number selector		
		AWG20	AWG18	AWG16							AWG20	AWG18	AWG16
4305	22-4305	X		NA	1.1 mm	1.65 mm	4.5 mm	x3		16459 / C16461	4		NA
4308	22-4308	NA	X	NA	1.35 mm	1.85 mm	4.5 mm	x2	OK	16459 / C16461	NA	5	NA
4310	22-4310		X		1.7 mm	NA	6 mm	x1		16459 / C16461	4	5	6

NA : Not Applicable

The conductor must be visible through the inspection window of the contact

1 - Insert the cable into the contact

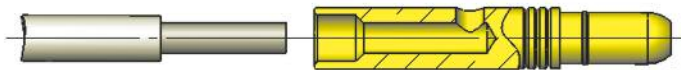

END STOP

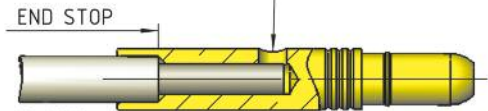

END STOP only for 22-X310



2 - Set the hand crimp tool according to crimp barrel accommodation table above.

2.1 - Select the number selector with the selector knob (see crimp tool setting).
2.2 - Put the positioner C16461 on the hand crimp tool 16459.

3 - Insert the contact and wire assembly in the crimp guide of the hand crimp tool.

3.1 - In the crimp guide, the contact and wire assembly must be in the ends stop position.
3.2 - During crimping, keep the wire in position.
3.3 - Just one crimping operation is allowed per contact and wire assembly.

Hand crimp tool in a closed position.

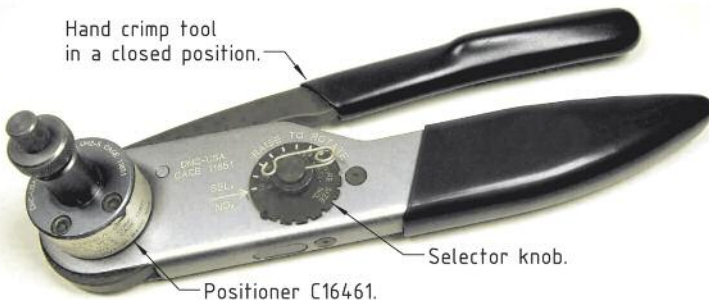

Selector knob.

Positioner C16461.

4 - Visually check crimping

4.1 - Crimping must not deform the inspection window.
4.2 - Contact must not have visible fractures or cracks.
4.3 - Contact barrel must not be deformed or bent.
4.4 - Crimping must not deform the end of the contact.

Inspection window

End of the contact



Hand crimp tool in an open position.

Crimp guide.



5 - Check it is firmly crimped by pulling gently

5.1 - For that purpose two (2) fingers are enough : pinch the wire and pull smoothly along the axis of the crimped contact

Cable instructions (IC30HP02)

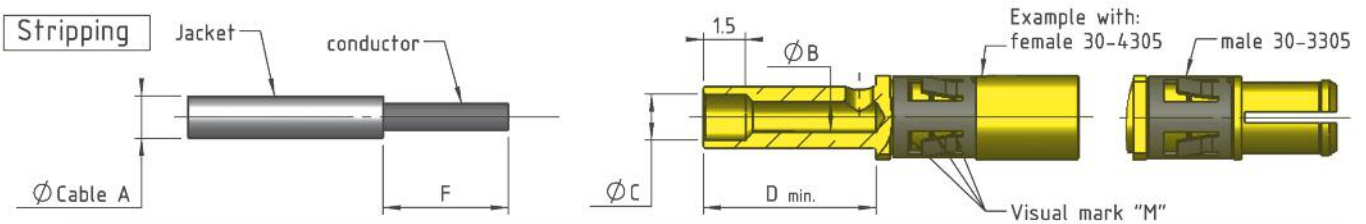

Loaded	Unloaded	Cable A					ØB	ØC	Length F conductor	Length D hole	M	Solder	Crimp by AF8 Tool / Positioner	Crimp tool setting - Number selector				
		AWG20	AWG18	AWG16	AWG14	AWG12								AWG20	AWG18	AWG16	AWG14	AWG12
3305	30-3305	X				NA	1.1 mm	1.65 mm	4.5 mm	6.2 mm	x3	16459 / C16460	3	NA				
3308	30-3308	NA	X			NA	1.35 mm	1.85 mm	6 mm		x2		OK	NA	4	NA		
3310	30-3310		X			NA	1.7 mm	NA		5.3 mm	x1	NA		4	4	5	NA	
3315	30-3315			X	NA		2 mm		2.6 mm				5.5 mm	NA	NA	NA		6
3320	30-3320			NA	X		2.6 mm									NA		NA

Loaded	Unloaded	Cable A					ØB	ØC	Length F conductor	Length D hole	M	Solder	Crimp by AF8 Tool / Positioner	Crimp tool setting - Number selector				
		AWG20	AWG18	AWG16	AWG14	AWG12								AWG20	AWG18	AWG16	AWG14	AWG12
4305	30-4305	X				NA	1.1 mm	1.65 mm	4.5 mm	6.2 mm	x3	16459 / C16460	3	NA				
4308	30-4308	NA	X			NA	1.35 mm	1.85 mm	6 mm		x2		OK	NA	4	NA		
4310	30-4310		X			NA	1.7 mm	NA		5.3 mm	x1	NA		4	4	5	NA	
4315	30-4315			X	NA		2 mm		2.6 mm				5.5 mm	NA	NA	NA		6
4320	30-4320			NA	X		2.6 mm									NA		NA

NA : Not Applicable

1 - Insert the cable into the contact



END STOP only for 30-X310, 30-X315 and 30-X320

2 - Set the hand crimp tool according to crimp barrel accommodation table above.

2.1 - Select the selector number with the selector knob (see crimp tool setting).
2.2 - Put the positioner C16460 on the hand crimp tool 16459.

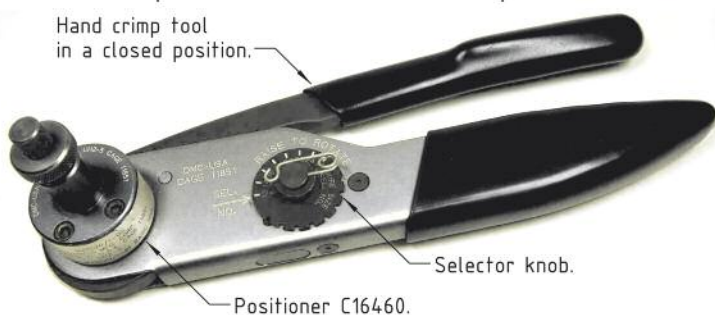

3 - Insert the contact and wire assembly in the crimp guide of the hand crimp tool.

- 3.1 - In the crimp guide, the contact and wire assembly must be in the end stop position.
- 3.2 - During crimping, keep the wire in position.
- 3.3 - Just one crimping operation is allowed per contact and wire assembly.

4 - visually check crimping

- 4.1 - Crimping must not deform the inspection window.
- 4.2 - Contact must not have visible fractures or cracks.
- 4.3 - Contact barrel must not be deformed or bent.
- 4.4 - Crimping must not deform the end of the contact

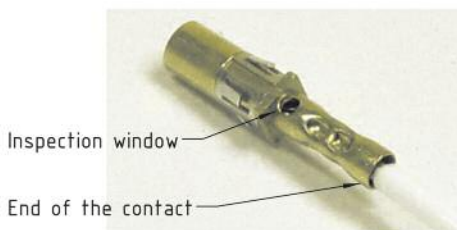

5 - Check it is firmly crimped by pulling gently

For that purpose two (2) fingers are enough : pinch the wire and pull smoothly along the axis of the crimped contact



Index

General information

CMM presentation	p 2
CMM specifications & dimension tables	p 3-4-5
Contacts information	p 7-11

Male and Female housings marking	p 12-13
Standard part numbering & product families	p 14-15
Custom products & innovations	p 125

CMM 100/200 Series

p 17-25

Contact arrangements & configuration	p 18-19
Male connectors	p 20-22

Female connectors	p 23-25
Retention latches information	p 22

CMM 220 Series

p 27-46

CMM LF introduction page	p 27
Contact arrangements & configuration	p 28
Male connectors with LF contacts	p 29-31
Female connectors with LF contacts	p 32-34
Mixed-Layout introduction page	p 35

Male connectors with Mixed-Layout	p 36-38
Female connectors with Mixed-Layout	p 39-41
Shifted polarization key position	p 42
Fixing hardware information	p 43-46

CMM 320 Series

p 47-59

CMM LF introduction page	p 47
Contact arrangements & configuration	p 48
Male connectors with LF contacts	p 49-50
Female connectors with LF contacts	p 51-52
Mixed-Layout introduction page	p 53

Male connectors with Mixed-Layout	p 54-56
Female connectors with Mixed-Layout	p 57-59
Fixing hardware information	p 69-74

CMM 340 Series

p 60-74

CMM 340 Mixed-Layout introduction page	p 60-61
Contact arrangements & configuration	p 62
Male connectors with Mixed-Layout	p 63-65

Female connectors with Mixed-Layout	p 66-68
Fixing hardware information	p 69-74

High frequency and high power contacts

p 75-102

Insertion & part numbering information for HF & HP contacts series 30	p 75
HF contacts series 30	p 76-86
30-1300-xx (Male straight on PCB)	p 76
30-2300-xx (Female straight on PCB)	p 76
30-1400-xx (Male 90° PCB)	p 77
30-2400-xx (Female 90° PCB)	p 77
30-1500-CMM (Male 90° SMT without LF)	p 78
30-1500-12 (Male 90° SMT for CMM220)	p 79
30-1500-12 (Male 90° SMT for CMM320)	p 80
30-1600 (Male straight SMT for CMM220)	p 81
30-2600 (Female straight SMT for CMM220)	p 81
30-1312-ZS (Male straight crimp on cable)	p 82
30-2312-ZS (Female straight crimp on cable)	p 82
30-13xx-SS / ZS (Male straight crimp on cable)	p 83
30-23xx-SS / ZS (Female straight crimp on cable)	p 83
30-14xx-ZS (Male 90° crimp on cable)	p 84
30-24xx-ZS (Female 90° crimp on cable)	p 84
30-13xx-ZZ (Male straight on semi-rigid cable)	p 85
30-23xx-ZZ (Female straight on semi-rigid cable)	p 85
30-14xx-ZZ (Male 90° on semi-rigid cable)	p 86
30-24xx-ZZ (Female 90° on semi-rigid cable)	p 86
HP contacts series 30	p 87-93
30-3300-xx (Male straight on PCB)	p 87
30-4300-xx (Female straight on PCB)	p 87
30-3400-xx (Male 90°)	p 88
30-4400-xx (Female 90°)	p 88

30-3500 (Male 90° SMT)	p 89
30-4500 (Female 90° SMT)	p 89
30-3600 (Male straight SMT)	p 90
30-4600 (Female straight SMT)	p 90
30-3500-CMM (Male 90° SMT Card Edge)	p 91
30-3500-12 (Male 90° SMT Card Edge CMM220)	p 92
30-3500-12 (Male 90° SMT Card Edge CMM320)	p 93
30-33xx (Male straight on cable)	p 94
30-43xx (Female straight on cable)	p 94

Insertion & part numbering information for HF & HP contacts series 22

HF contacts series 22	p 96-99
22-1300-xx (Male straight on PCB)	p 96
22-2300-xx (Female straight on PCB)	p 96
22-1400-xx (Male 90° PCB)	p 97
22-2400-xx (Female 90° PCB)	p 97
22-1312-ZS-xx (Male straight to crimp on cable)	p 98
22-2312-ZS-xx (Female straight to crimp on cable)	p 98
22-1320-ZZ (Male straight on cable)	p 99
22-2320-ZZ (Female straight on cable)	p 99
HP contacts series 22	p 100-102
22-3300-xx (Male straight on PCB)	p 100
22-4300-xx (Female straight on PCB)	p 100
22-3400-xx (Male 90° on PCB)	p 101
22-4400-xx (Female 90° on PCB)	p 101
22-33xx (Male straight on cable)	p 102
22-43xx (Female straight on cable)	p 102

Tools and accessories

p 103-112

Cable instructions & assembly

p 113-122

Index

p 123

Notes

p 124

Manufacturer and designer of innovative interconnect solutions



MICRO-D MIX™ DMM SERIES MICRO-CONNECTORS

2mm pitch high density robust metal shielded micro connector
Self cabling connector
Simple and easy to design-in
New alternative under MIL-DTL-83513G or MIL-DTL-55302F test routine
Very flexible custom design (fixing hardware, contacts...)

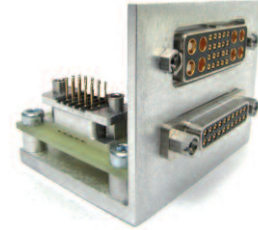

OMM SERIES MICRO-CIRCULAR CONNECTORS

High density of contacts in smallest circular connector shape
Space saving feature
Security of connection
Light weight
Lockable captive fixing hardware



MICROFLEX HARNESS SOLUTION

Low weight: save up to -30% vs. bulky cable
Smaller space-factor
2 in 1 technology with CMM & CRIMP FLEX
Avionic & aerospace MIL comply
High quality of crimp (gaz tie)
High productivity: 2 to 30 contacts in 1 crimp



4D-FLOATING CONNECTORS

4D tolerance absorption: 4D = 3 axial movements + 1 rotation
High efficiency "Bone design" (round shape and 4 spring-lips contact)
Complies with MIL-DTL-55302F
Auto alignment feature
Adaptable to customer requests

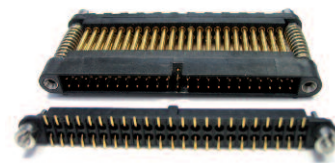

CUSTOM PRODUCTS

You can rely on our R&D department know-how and long experience.
Our permanent innovation was recognized and labeled as "highly Innovative" by the European Union
Our in-house production and assembly capacity offers you the possibility to create customized products : stamping and moulding, micro-screw machining, laser cut, CNC, specific machinery development, clean room, measure and test lab.
Fully integrated industrial company, Nicomatic can reduce your risks, can secure your development and achieve the solution that will make the difference on the market.



Date of issue : May 2011
Catalogue reference : C.CMM.1000/GB

NICOMATIC maintains a policy of ongoing development and improvement. It therefore reserves the right to change design, dimensions and specifications without notice. All information stated inside this catalogue is not contractual and subject to change (eg. standard connector configurations).

Copyright 2011 by NICOMATIC (All Rights Reserved)
法国Nicomatic代理商中国统一热线4006-022-002 上海 深圳 北京 天津 湖南省株洲

shunto@126.com 高密度连接器价格查询 www.shonto.cn

NICOMATIC 125