

THIS DRAWING IS UNPUBLISHED. RELEASED FOR PUBLICATION  
 © COPYRIGHT - By - ALL RIGHTS RESERVED.

LOC		DIST		REVISIONS			
P	LTR	DESCRIPTION		DATE	DWN	APVD	
CM	00	AB4	REVISED PER ECO-11-020968	18OCT11	JR	SM	

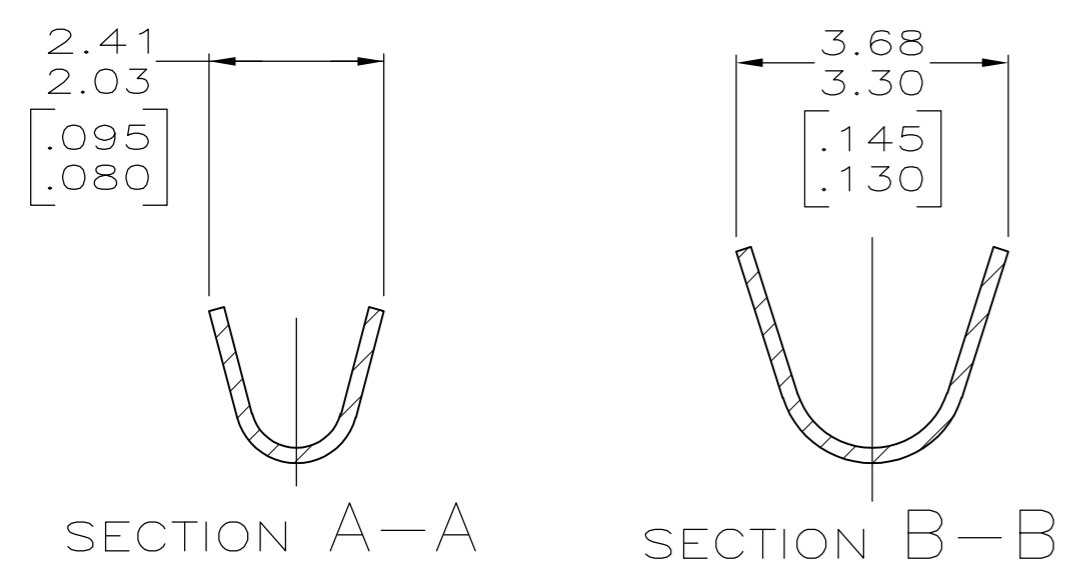
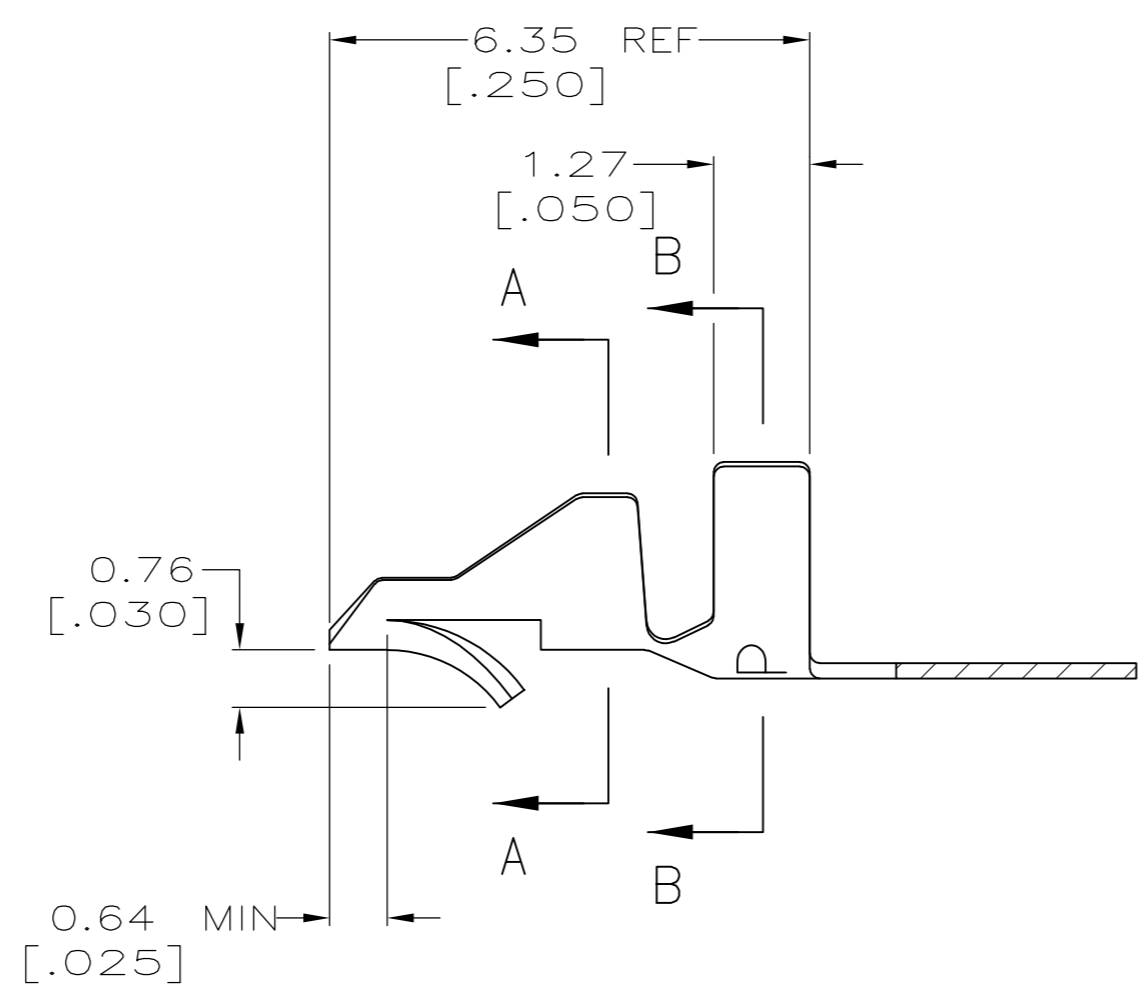
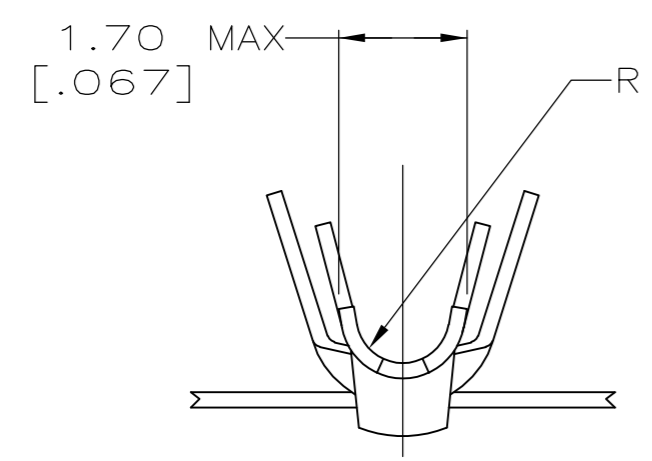
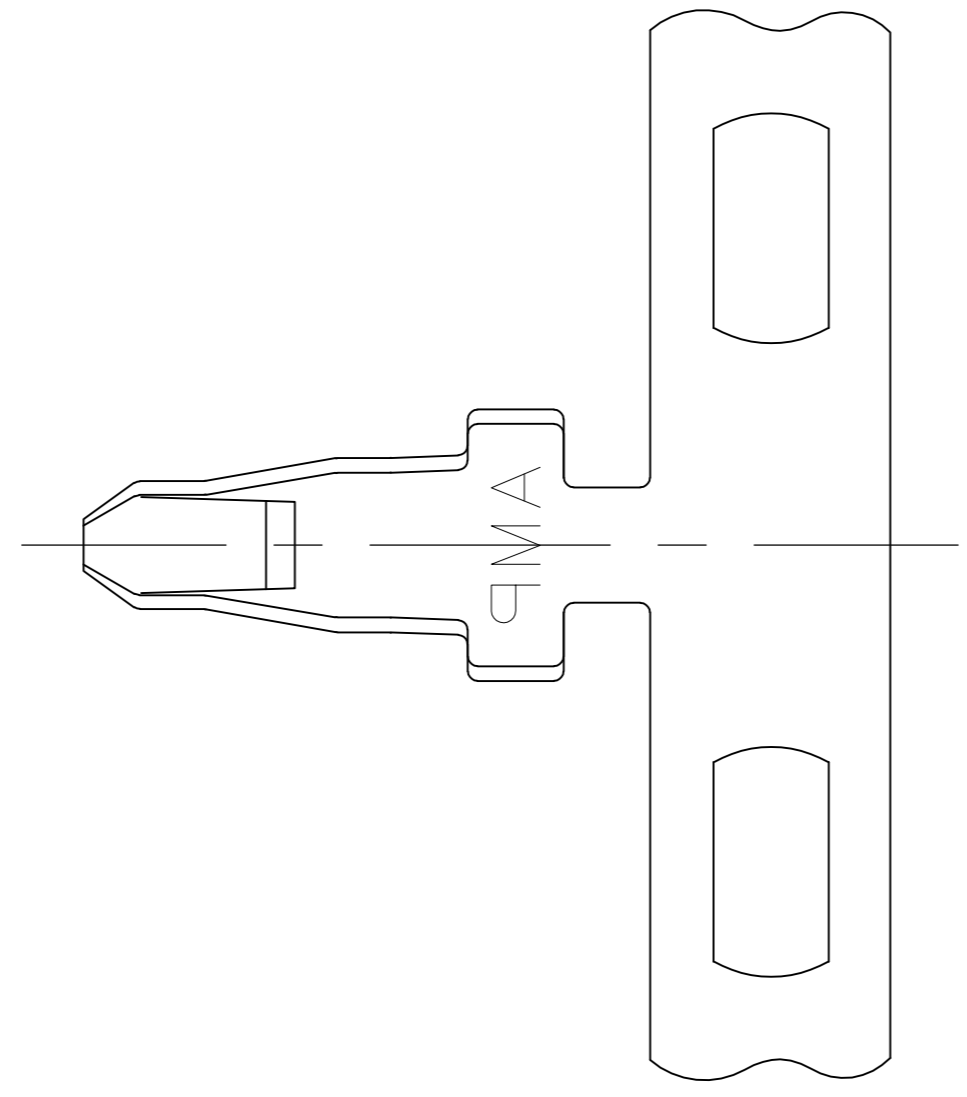
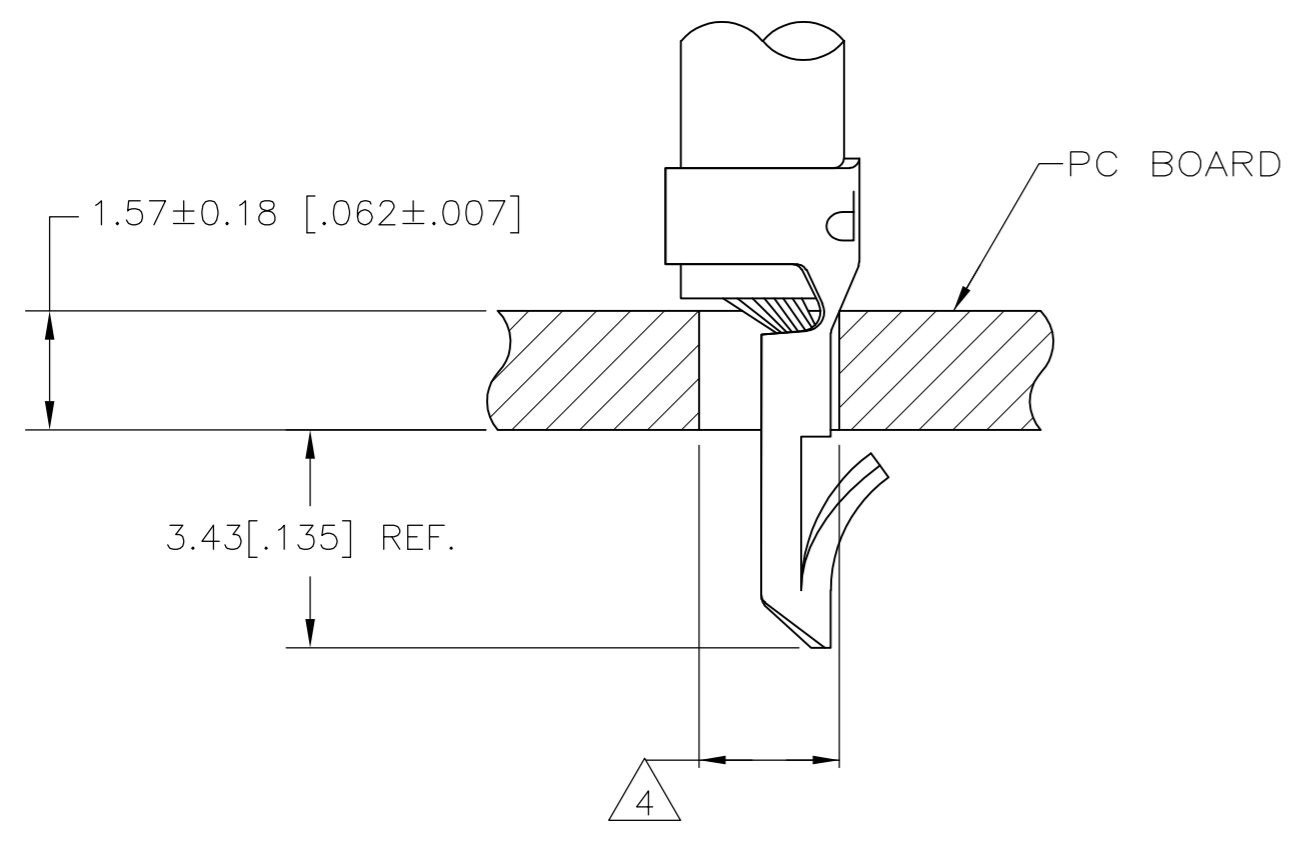

- 1 PARTS COMPLY WITH AMP SOLDERABILITY SPEC 109-11-3.
- 2 PARTS COMPLY WITH AMP SOLDERABILITY SPEC 109-11-5.
- 3 PARTS COMPLY WITH AMP SOLDERABILITY SPEC 109-11-1.
- 4 HOLE DIAMETER TO BE 1.83±0.08 FOR WIRE 0.3-0.6mm<sup>2</sup> (20-22 AWG ) OR 1.96±0.08 FOR WIRE 0.8-0.9mm<sup>2</sup> (18 AWG).
- 5 CARRIER STRIP TO HAVE 1.52 [.060] DIA PILOT HOLE.
- 6 0.00508 [.000200] MIN BRIGHT TIN-LEAD.
- 7 0.00318 [.000150] MIN MATTE TIN-LEAD OVER 0.00305 [.000120] MIN MATTE COPPER.
- 8 0.00305 [.000120] MIN TIN OVER 0.00102 [.000040] MIN NICKEL.
- 9 WIRE RANGE: 0.3 -0.9 mm<sup>2</sup> (22 - 18 AWG).
- 10 INSULATION RANGE: 1.52 - 2.79 [.060 - .110] DIA.
- 11 DIMENSIONS IN BRACKETS ARE IN INCHES.
- 12 0.00508 [.000200] MIN BRIGHT TIN.

NOTES	FINISH	MATERIAL	PART NO.
1	12	0.20 [.008] PH BRZ	3-350566-1
3	5	0.20 [.008] BRASS	350566-7
3	8	0.20 [.008] BRASS	350566-5
2	8	0.20 [.008] BRASS	350566-3
1	6	0.20 [.008] PH BRZ	350566-1

THIS DRAWING IS A CONTROLLED DOCUMENT.

DWN S. CARPENTER 20AUG2003	TE Connectivity MINI AMP-IN (TM)				
CHK J. ELLIS 20AUG2003					
APVD J. ELLIS 20AUG2003					
PRODUCT SPEC					
APPLICATION SPEC 114-1016	NAME				
MATERIAL SEE TABLE	WEIGHT	SIZE A2	CAGE CODE 00779	DRAWING NO C-350566	RESTRICTED TO -
TOLERANCES UNLESS OTHERWISE SPECIFIED: 0 PLC ± 1 PLC ± 2 PLC ± 3 PLC ± 0.13 [.005] 4 PLC ± ANGLES ±	FINISH SEE TABLE	CUSTOMER DRAWING	SCALE 10:1	SHEET 1 of 1	REV AB4

