

---

# LM2901, LM339/LM339A, LM3302, LM239/LM239A

## Quad Comparator

### Features

- Single or dual supply operation
- Wide range of supply voltage  
LM2901, LM339/LM339A, LM239/LM239A : 2 ~ 36V  
(or  $\pm 1 \sim \pm 18V$ )  
LM3302 : 2 ~ 28V (or  $\pm 1 \sim \pm 14V$ )
- Low supply current drain 800 $\mu$ A Typ.
- Open collector outputs for wired and connectors
- Low input bias current 25nA Typ.
- Low Input offset current  $\pm 2.3$ nA Typ.
- Low input offset voltage  $\pm 1.4$ mV Typ.
- Common mode input voltage range includes ground.
- Low output saturation voltage
- Output compatible with TTL, DTL and MOS logic system

### Description

The LM2901, LM339/LM339A, LM239/LM239A, LM3302 consist of four independent voltage comparators designed to operate from single power supply over a wide voltage range.

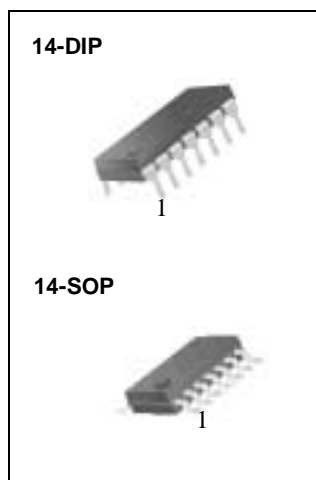

### Internal Block Diagram

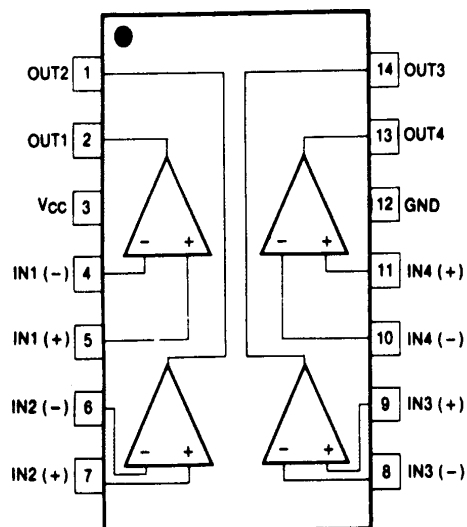

## Schematic Diagram

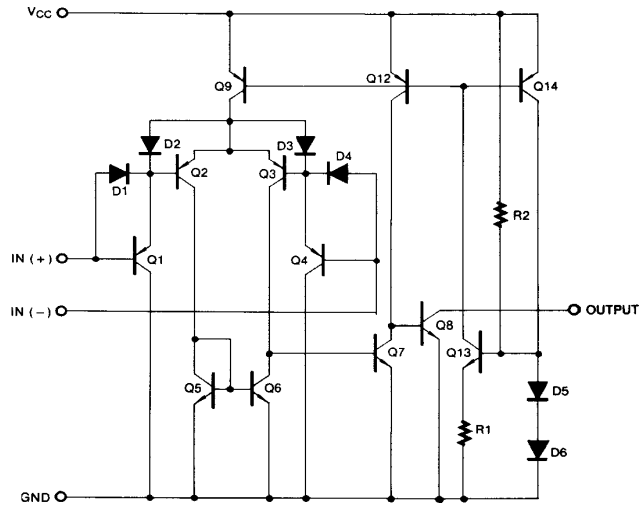

## Absolute Maximum Ratings

Parameter	Symbol	Value	Unit
Supply Voltage	VCC	±18 or 36	V
Supply Voltage only LM3302	VCC	±14 or 28	V
Differential Input Voltage	V <sub>I(DIFF)</sub>	36	V
Differential Input Voltage only LM3302	V <sub>I(DIFF)</sub>	28	V
Input Voltage	V <sub>I</sub>	- 0.3 to +36	V
Input Voltage only LM3302	V <sub>I</sub>	- 0.3 to +28	V
Output Short Circuit to GND	-	Continuous	-
Power Dissipation	P <sub>D</sub>	570	mW
Operating Temperature			
LM339/LM339A	T <sub>OPR</sub>	0 ~ + 70	°C
LM2901/LM3302		-40 ~ + 85	
LM239/LM239A		-25 ~ + 85	
Storage Temperature	T <sub>STG</sub>	- 65 ~ + 150	°C

## Electrical Characteristics

(VCC = 5V, TA = 25°C, unless otherwise specified)

Parameter	Symbol	Conditions	LM239A/LM339A			LM239/LM339			Unit
			Min	Typ	Max	Min	Typ	Max	
Input Offset Voltage	V <sub>IO</sub>	V <sub>O(P)</sub> = 1.4V, R <sub>S</sub> = 0Ω	-	±1	±2	-	±1.4	±5	mV
			Note 1	-	-	±4.0	-	-	
Input Offset Current	I <sub>IO</sub>		-	±2.3	±50	-	±2.3	±50	nA
			Note 1	-	-	±150	-	-	
Input Bias Current	I <sub>BIAS</sub>		-	57	250	-	57	250	nA
			Note 1	-	-	400	-	-	
Input Common Mode Voltage Range	V <sub>I(R)</sub>		0	-	V <sub>CC</sub> -1.5	0	-	V <sub>CC</sub> -1.5	V
			Note 1	0	-	V <sub>CC</sub> -2	0	-	
Supply Current	I <sub>CC</sub>	V <sub>CC</sub> = 5V R <sub>L</sub> = ∞	-	1.1	2.0	-	1.1	2.0	mA
Voltage Gain	G <sub>V</sub>	V <sub>CC</sub> = 15V, R <sub>L</sub> ≥ 15KΩ (for large swing)	50	200	-	50	200	-	V/mV
Large Signal Response Time	T <sub>LRES</sub>	V <sub>I</sub> = TTL Logic Swing V <sub>REF</sub> = 1.4V, V <sub>RL</sub> = 5V, R <sub>L</sub> = 5.1KΩ	-	350	-	-	350	-	ns
Response Time	T <sub>RES</sub>	V <sub>RL</sub> = 5V, R <sub>L</sub> = 5.1KΩ	-	1.4	-	-	1.4	-	μs
Output Sink Current	I <sub>SINK</sub>	V <sub>I(-)</sub> ≥ 1V, V <sub>I(+)</sub> = 0V, V <sub>O(P)</sub> ≤ 1.5V	6	18	-	6	18	-	mA
Output Saturation Voltage	V <sub>SAT</sub>	V <sub>I(-)</sub> ≥ 1V, V <sub>I(+)</sub> = 0V I <sub>SINK</sub> = 4mA	-	140	400	-	140	400	mV
			Note 1	-	-	700	-	-	
Output Leakage Current	I <sub>o(LKG)</sub>	V <sub>I(-)</sub> = 0V V <sub>I(+)</sub> = 1V	V <sub>O(P)</sub> = 5V	-	0.1	-	-	0.1	nA
			V <sub>O(P)</sub> = 30V	-	-	1.0	-	-	1.0
Differential Voltage	V <sub>I(DIFF)</sub>		Note 1	-	-	36	-	-	V

### Note 1.

LM339/LM339A : 0 ≤ T<sub>A</sub> ≤ +70°C

LM2901/LM3302 : -40 ≤ T<sub>A</sub> ≤ +85°C

LM239/LM239A : -25 ≤ T<sub>A</sub> ≤ +85°C

**Electrical Characteristics (Continued)**

(VCC = 5V, TA = 25°C, unless otherwise specified)

Parameter	Symbol	Conditions	LM2901			LM3302			Unit
			Min	Typ	Max.	Min	Typ	Max.	
Input Offset Voltage	V <sub>IO</sub>	V <sub>O(P)</sub> = 1.4V, R <sub>S</sub> = 0Ω	-	2	7	-	2	20	mV
		Note 1	-	9	15	-	-	40	
Input Offset Current	I <sub>IO</sub>		-	2.3	50	-	3	100	nA
		Note 1	-	50	200	-	-	300	
Input Bias Current	I <sub>BIAS</sub>		-	57	250	-	57	250	nA
		Note 1	-	200	500	-	-	1000	
Input Common Mode Voltage Range	V <sub>I(R)</sub>		0	-	V <sub>CC</sub> -1.5	0	-	V <sub>CC</sub> -1.5	V
		Note 1	0	-	V <sub>CC</sub> -2	0	-	V <sub>CC</sub> -2	
Supply Current	I <sub>CC</sub>	R <sub>L</sub> = ∞, V <sub>CC</sub> = 5V	-	1.1	2.0	-	1.1	2.0	mA
		R <sub>L</sub> = ∞, V <sub>CC</sub> = 30V	-	1.6	2.5	-	-	-	
Voltage Gain	G <sub>V</sub>	V <sub>CC</sub> = 15V, R <sub>L</sub> ≥ 15KΩ (for large swing)	25	100	-	2	30	-	V/ mV
Large Signal Response Time	T <sub>LR</sub>	V <sub>I</sub> = TTL Logic Swing V <sub>REF</sub> = 1.4V, V <sub>RL</sub> = 5V, R <sub>L</sub> = 5.1KΩ	-	350	-	-	350	-	ns
Response Time	T <sub>RES</sub>	V <sub>RL</sub> = 5V, R <sub>L</sub> = 5.1KΩ	-	1.4	-	-	1.4	-	μs
Output Sink Current	I <sub>SINK</sub>	V <sub>I(-)</sub> ≥ 1V, V <sub>I(+)</sub> = 0V, V <sub>O(P)</sub> ≤ 1.5V	6	18	-	6	18	-	mA
Output Saturation Voltage	V <sub>SAT</sub>	V <sub>I(-)</sub> ≥ 1V, V <sub>I(+)</sub> = 0V	-	140	400	-	140	400	mV
		I <sub>SINK</sub> = 4mA	Note 1	-	-	700	-	-	
Output Leakage Current	I <sub>O(LKG)</sub>	V <sub>I(-)</sub> = 0V	-	0.1	-	-	0.1	-	nA
		V <sub>I(+)</sub> = 1V	-	-	1.0	-	-	1.0	μA
Differential Voltage	V <sub>I(DIFF)</sub>	Note 1	-	-	36	-	-	36	V

**Note 1.**LM339/LM339A : 0 ≤ T<sub>A</sub> ≤ +70°CLM2901/LM3302 : -40 ≤ T<sub>A</sub> ≤ +85°CLM239/LM239A : -25 ≤ T<sub>A</sub> ≤ +85°C

## Typical Performance Characteristics

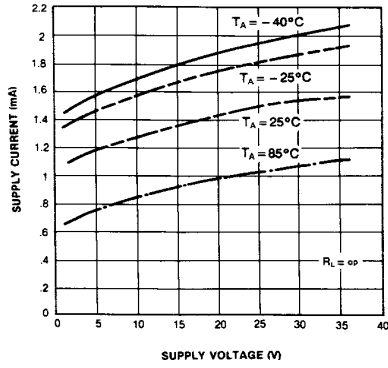

Figure 1. Supply Current vs Supply Voltage

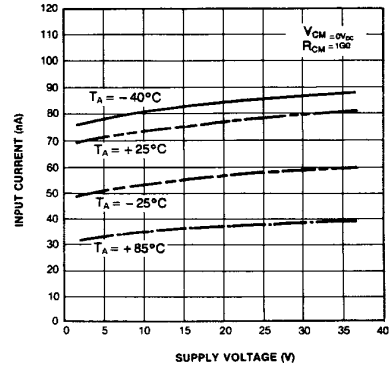

Figure 2. Input Current vs Supply Voltage

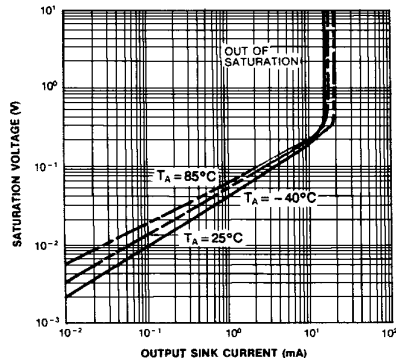

Figure 3. Output Saturation Voltage vs Sink Current

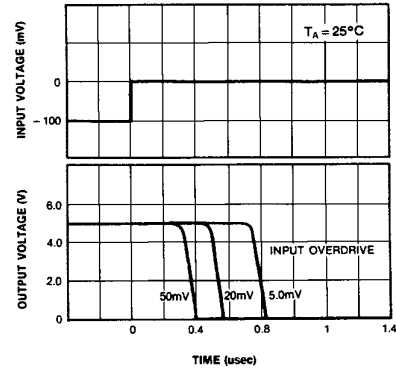

Figure 4. Response Time for Various Input Overdrive-Negative Transition

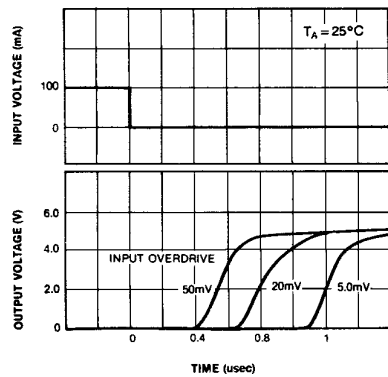
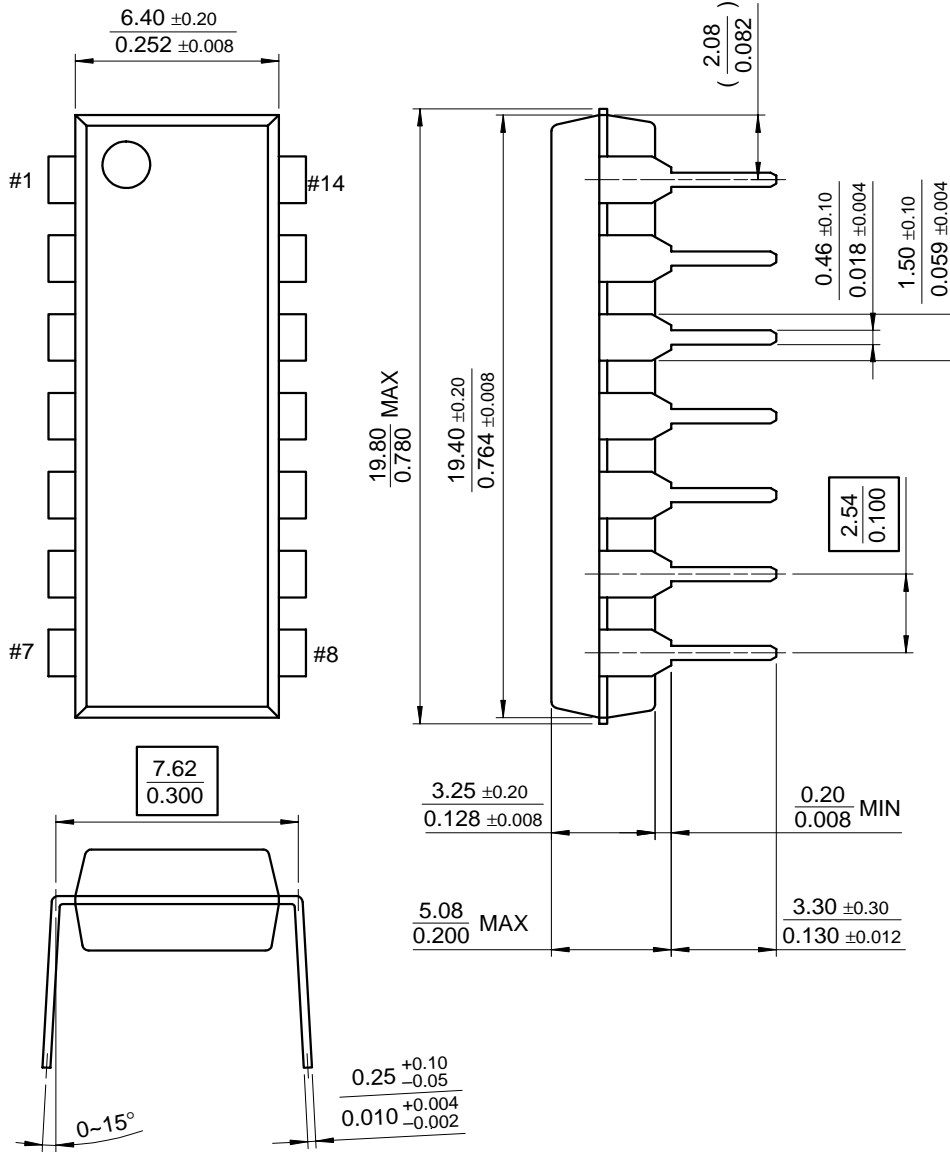

Figure 5. Response Time for Various Input Overdrive-Positive Transition

# Mechanical Dimensions

## Package

### 14-DIP



**Mechanica Dimensions** (Continued)

**Package**

**14-SOP**

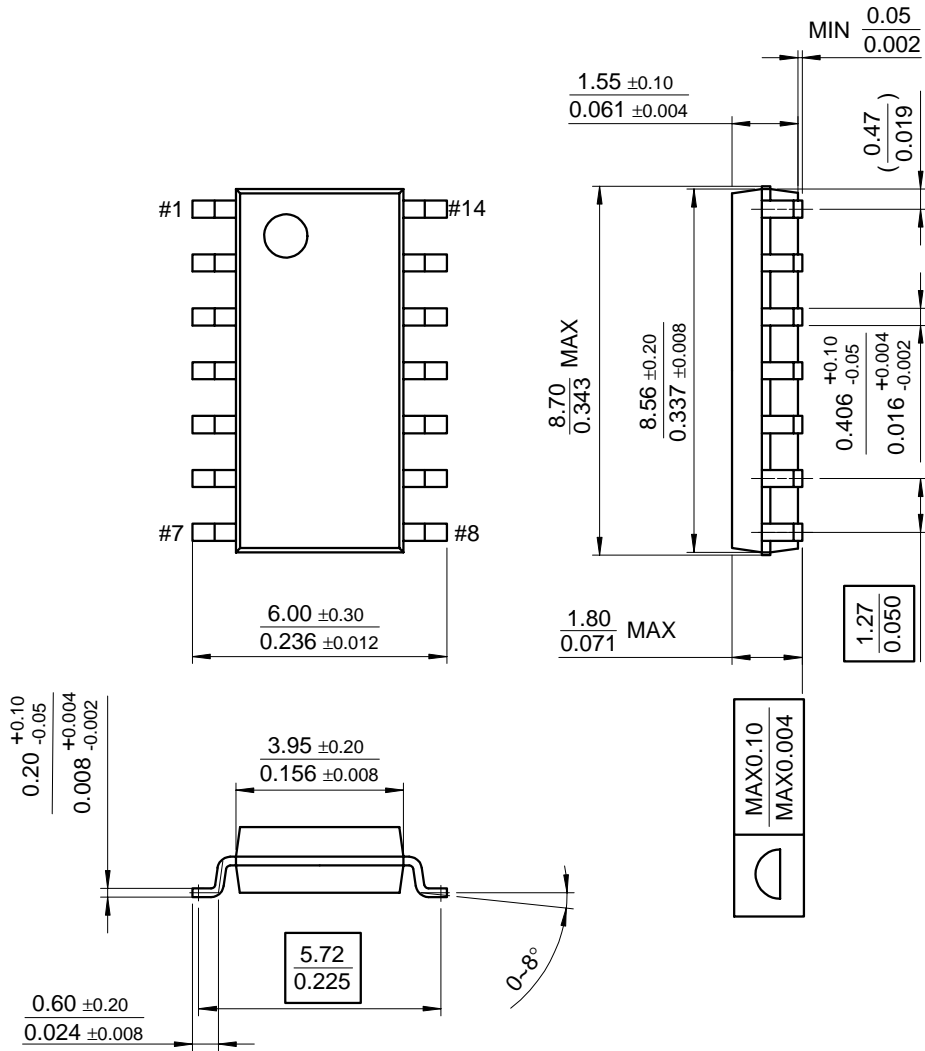

**Ordering Information**

Product Number	Package	Operating Temperature
LM339N	14-DIP	0 ~ + 70°C
LM339AN		
LM339M	14-SOP	
LM339AM		
LM2901N	14-DIP	-40 ~ + 85°C
LM2901M	14-SOP	
LM3302N	14-DIP	
LM3302M	14-SOP	
LM239N	14-DIP	-25 ~ + 85°C
LM239AN		
LM239M	14-SOP	
LM239AM		