

## FEATURES

- No frequency Compensation Required
- No latch-up
- Large common mode and differential voltage range
- Parameter tracking over temperature range
- Gain and phase match between amplifiers
- Internally frequency compensated
- Low noise input transistors

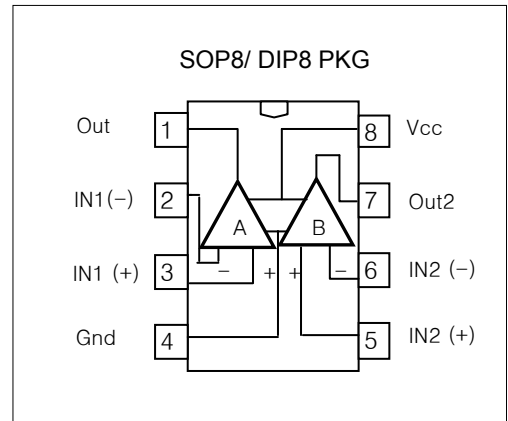

## ORDERING INFORMATION

Device	Package
LM4558D	8 SOP
LM4558N	8 DIP

## DESCRIPTIONS

The LM4558 devices is a monolithic integrated circuit designed for dual operational amplifier. The high common-mode input voltage range and the absence of latch-up make these amplifiers ideal for voltage-follower applications. The devices are short-circuit protected and the internal frequency compensation ensures stability without external components.

The LM4558 is characterized for operation from 0°C TO 70°C.

## SCHEMATIC (EACH AMPLIFIER)

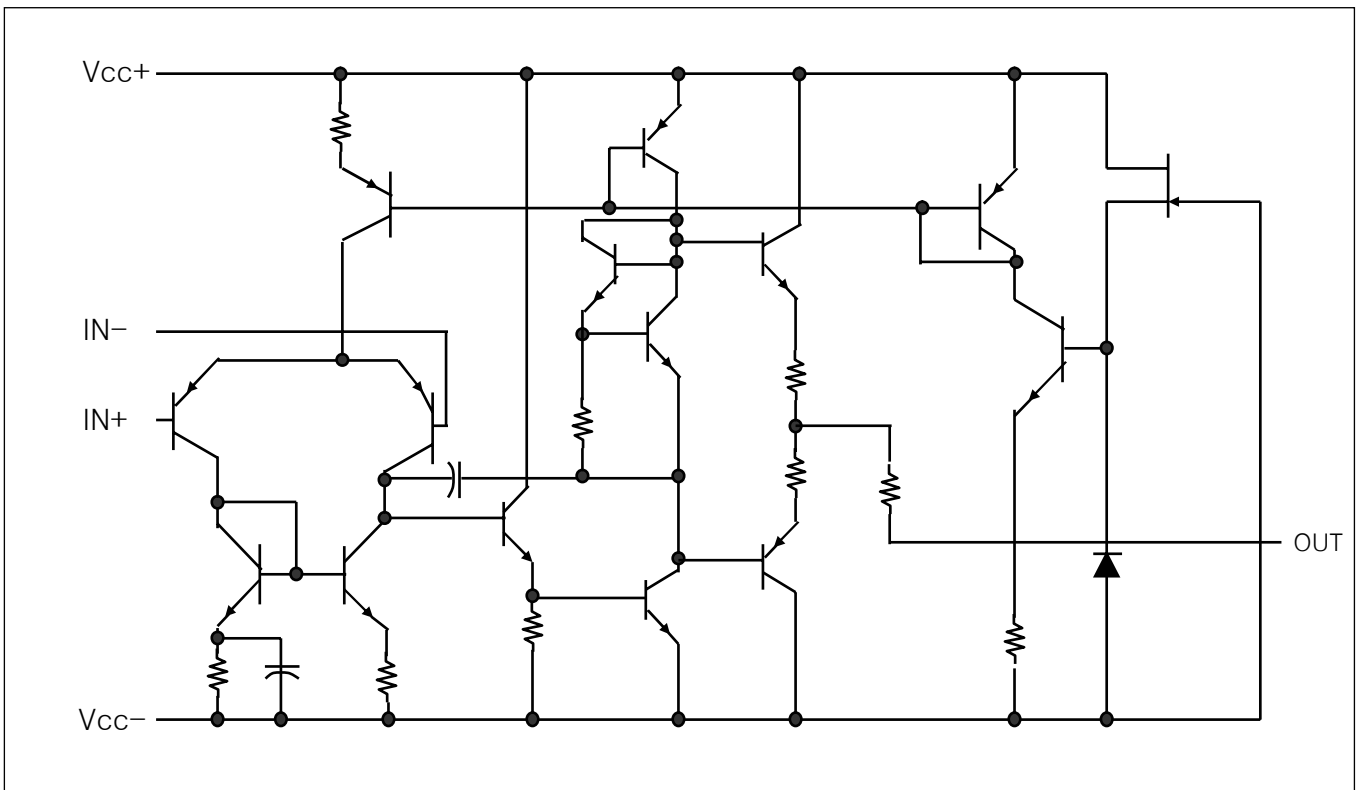

# DUAL OPERATIONAL AMPLIFIERS

# LM4558

Absolute maximum ratings over operating free-air temperature range.

		LM4558	UNIT
Supply Voltage	$V_{CC}$	$\pm 22$	V
Differential Input Voltage	$V_{I(DIFF)}$	$\pm 30$	V
Input Voltage	$V_I$	$\pm 15$	V
Duration of output short circuit to ground, one amplifier at a time		Unlimited	
Short temperature range	$T_{stg}$	-65 to 150	°C

Recommended operating conditions

		MIN	MAX	UNIT
Supply voltage	$V_{CC+}$	5	15	V
	$V_{CC-}$	-5	-15	
Operating free-air temperature, $T_A$	LM4558	0	70	°C

Electrical characteristics at specified free-air temperature,  $V_{CC} = 15V$  (unless otherwise noted)

PARAMETER	TEST CONDITIONS*	LM4558			UNIT
		MIN	TYP	MAX	
$V_{IO}$ Input Offset Voltage	$V_O=0$	25°C	0.5	5	mV
		Full Range		6	
$V_{O1}/V_{O2}$ Crosstalk attenuation	Open $A_{VD}=100$	25°C $R_S=100\ \Omega$ $f=1\ \text{kHz}$	85		
			100		
$I_{IO}$ Input Offset Current	$V_O=0$	25°C	5	200	nA
		Full Range		500	
$r_J$	Input resistance	25°C	0	5	M $\Omega$
$I_{IB}$ Input Bias Current	$V_O=0$	25°C	140	500	nA
		Full Range		1500	
$V_{ICR}$ Common-Mode Input Voltage range		25°C	$\pm 12$	$\pm 14$	V
VOM Maximum output voltage swing	$R_L = 10\ \text{k}\Omega$	25°C	$\pm 12$	$\pm 14$	V
	$R_L = 2\ \text{k}\Omega$	25°C	$\pm 10$	$\pm 13$	
	$R_L \geq 2\ \text{k}\Omega$	Full Range	$\pm 10$		
$A_{VD}$ Large-Signal Differential Voltage Amplification	$V_O = \pm 10V$ $R_L \geq 2\ \text{k}\Omega$	25°C	50	350	V/mV
		Full Range	25		
CMRR Common-Mode Rejection Ratio	$V_{CC}=5V$ to MAX, $V_{IC}=V_{ICR}$ MIN	25°C	65	80	dB
$K_{SVS}$ Supply Voltage Sensitivity Ratio ( $\Delta V_{IO}/\Delta V_{CC}$ )		25°C	30	150	$\mu V/V$
$V_{O1}/V_{O2}$ Crosstalk Attenuation	$f=1\ \text{kHz}$ to 20kHz	25°C	120		dB
$I_{CC}$ Supply Current (Both Amplifiers)	$V_O=0$ , No Load	25°C	2.5	5.6	mA
		$T_A(\text{min})$	3.0	6.6	
		$T_A(\text{max})$	2.0	5.0	

\* All characteristics are measured under open-loop conditions with zero common-mode input voltage unless otherwise specified. Full range is 0°C to 70°C.  $T_A(\text{min}) = 0^\circ\text{C}$ .  $T_A(\text{max}) = 70^\circ\text{C}$ .

## TYPICAL PERFORMANCE CHARACTERISTICS

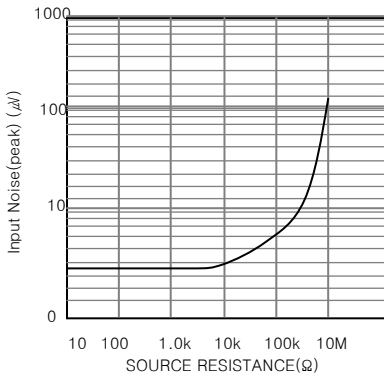

Figure 1. Burst Noise vs Source Resistance

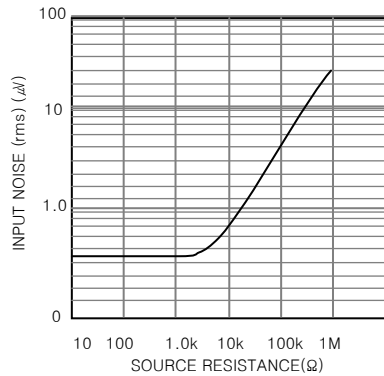

Figure 2. RMS Noise vs Source Resistance

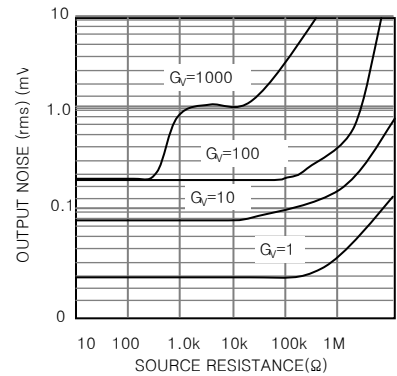

Figure 3. Output Noise vs Source Resistance

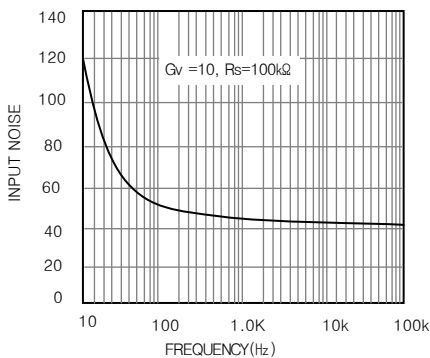

Figure 4. Spectral Noise Density

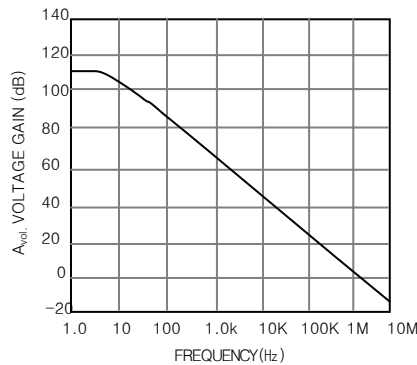

Figure 5. Open Loop Frequency Response

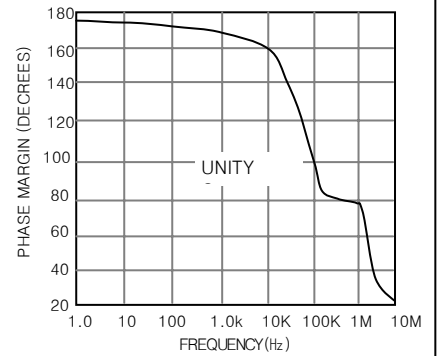

Figure 6. Phase Margin vs Frequency

### OUTPUT CHARACTERISTICS CURRENT SINKING

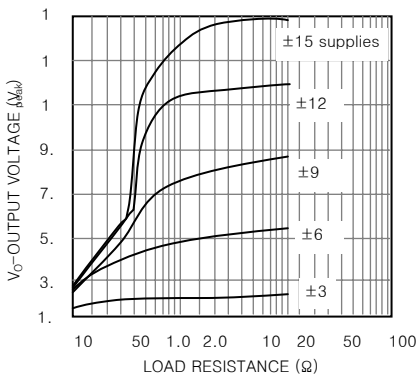

Figure 7. Positive Output Voltage Swing vs Load Resistance

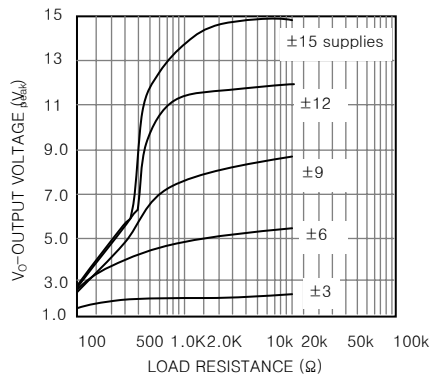

Figure 7. Negative Output Voltage Swing vs Load Resistance

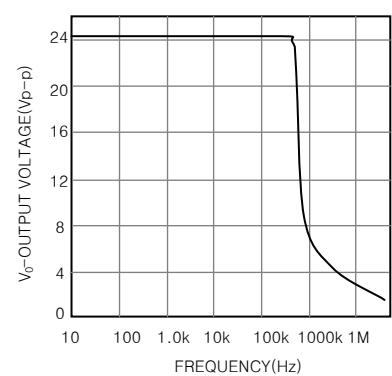

Figure 9. Power Bandwidth