

## Description

### Features

$V_{DSS}$	$R_{DS(ON)}$ @ 10V (typ)	$I_D$
100V	21m $\Omega$	59 A

- Fast switching
- 100% avalanche tested
- Improved dv/dt capability

### Application

- UPS
- Inverter
- Electric tools
- High efficiency switch mode power supplies

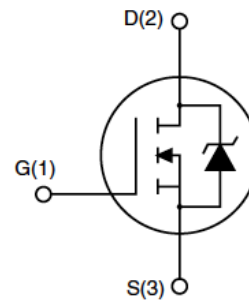
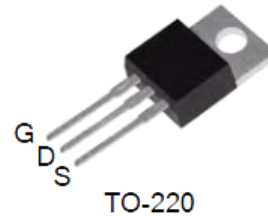

## Absolute Maximum Ratings $T_C=25^\circ\text{C}$ unless otherwise specified

Symbol	Parameter		Max.	Units
			TO-220	
$V_{DSS}$	Drain-Source Voltage		100	V
$V_{GSS}$	Gate-Source Voltage		$\pm 20$	V
$I_D$	Continuous Drain Current	$T_C = 25^\circ\text{C}$	59	A
		$T_C = 100^\circ\text{C}$	37.8	A
$I_{DM}$	Pulsed Drain Current <sup>note1</sup>		180	A
$I_{AR}$	Avalanche Current <sup>note1</sup>		29.5	A
$E_{AR}$	Repetitive Avalanche Energy <sup>note1</sup>		20	mJ
dv/dt	Peak Diode Recovery Energy <sup>note3</sup>		5.5	V/ns
$P_D$	Power Dissipation	$T_C = 25^\circ\text{C}$	200	W
	Linear Derating Factor	$T_C > 25^\circ\text{C}$	1.3	W/ $^\circ\text{C}$
$R_{\theta JC}$	Thermal Resistance, Junction to Case		0.75	$^\circ\text{C}/\text{W}$
$T_J, T_{STG}$	Operating and Storage Temperature Range		-55 to +175	$^\circ\text{C}$

\*Drain current limited by maximum junction temperature

## Electrical Characteristics $T_C=25^\circ\text{C}$ unless otherwise specified

Symbol	Parameter	Test Condition	Min.	Typ.	Max.	Units
<b>Off Characteristic</b>						
$V_{(BR)DSS}$	Drain-Source Breakdown Voltage	$V_{GS} = 0V, I_D = 250\mu A$	100	-	-	V
$\frac{\Delta V_{(BR)DSS}}{\Delta T_J}$	Breakdown Voltage Temperature Coefficient	Reference to $25^\circ\text{C}$ , $I_D = 250\mu A$	-	0.1	-	$V/^\circ\text{C}$
$I_{DSS}$	Zero Gate Voltage Drain Current	$V_{DS} = 100V, V_{GS} = 0V$	-	-	1	$\mu A$
		$V_{DS} = 80V, T_C = 125^\circ\text{C}$	-	-	10	$\mu A$
$I_{GSS}$	Gate to Body Leakage Current	$V_{DS} = 0V, V_{GS} = \pm 20V$	-	-	$\pm 100$	nA
<b>On Characteristics</b>						
$V_{GS(th)}$	Gate Threshold Voltage <sup>note4</sup>	$V_{DS} = V_{GS}, I_D = 250\mu A$	2	-	4	V
$R_{DS(on)}$	Static Drain-Source On-Resistance	$V_{GS} = 10V, I_D = 29.5A$	-	21	25	m $\Omega$
$g_{FS}$	Forward Transconductance	$V_{DS} = 20V, I_D = 29.5A$	32	-	-	S
<b>Dynamic Characteristics</b>						
$C_{iss}$	Input Capacitance	$V_{DS} = 25V, V_{GS} = 0V,$ $f = 1.0\text{MHz}$	-	3209	-	pF
$C_{oss}$	Output Capacitance		-	665.3	-	pF
$C_{riss}$	Reverse Transfer Capacitance		-	108.7	-	pF
$Q_g$	Total Gate Charge	$V_{DD} = 80V, I_D = 29.5A,$ $V_{GS} = 10V$	-	109	-	nC
$Q_{gs}$	Gate-Source Charge		-	23.1	-	nC
$Q_{gd}$	Gate-Drain("Miller") Charge		-	34.8	-	nC
EAS	Single Pulse Avalanche Energy <sup>note2</sup>	$I_{AS} = 15A, L = 10\text{mH}$	-	1125 <sup>note5</sup>	292 <sup>note6</sup>	mJ
<b>Switching Characteristics</b>						
$t_{d(on)}$	Turn-On Delay Time	$V_{DD} = 50V, I_D = 29.5A,$ $R_G = 5\Omega, V_{GS} = 10V$	-	19.3	-	ns
$t_r$	Turn-On Rise Time		-	52.5	-	ns
$t_{d(off)}$	Turn-Off Delay Time		-	53.2	-	ns
$t_f$	Turn-Off Fall Time		-	26.1	-	ns
<b>Drain-Source Diode Characteristics and Maximum Ratings</b>						
$I_S$	Maximum Continuous Drain to Source Diode Forward Current		-	-	59	A
$I_{SM}$	Maximum Pulsed Drain to Source Diode Forward Current		-	-	230	A
$V_{SD}$	Drain to Source Diode Forward Voltage	$V_{GS} = 0V, I_S = 29.5A$	-	-	1.3	V
$t_{rr}$	Reverse Recovery Time	$V_{GS} = 0V, I_F = 29.5A,$ $di/dt = 100A/\mu s$	-	122.5	-	ns
$Q_{rr}$	Reverse Recovery Charge		-	540	-	nC

Notes:

1. Repetitive Rating: Pulse width limited by maximum junction temperature
2.  $L = 10\text{mH}, I_{AS} = 15A, V_{DD} = 50V, R_G = 25\Omega$ , Starting  $T_J = 25^\circ\text{C}$
3.  $I_{SD} \leq 29.5A, di/dt \leq 200A/\mu s, V_{DD} \leq B_{VDSS}$ , Starting  $T_J = 25^\circ\text{C}$
4. Pulse width  $\leq 300\mu s$ ; duty cycle  $\leq 2\%$ .
5. This is a typical value at device destruction and represents operation outside rated limits.
6. This is a calculated value limited to  $T_J = 175^\circ\text{C}$ .

Typical Performance Characteristics

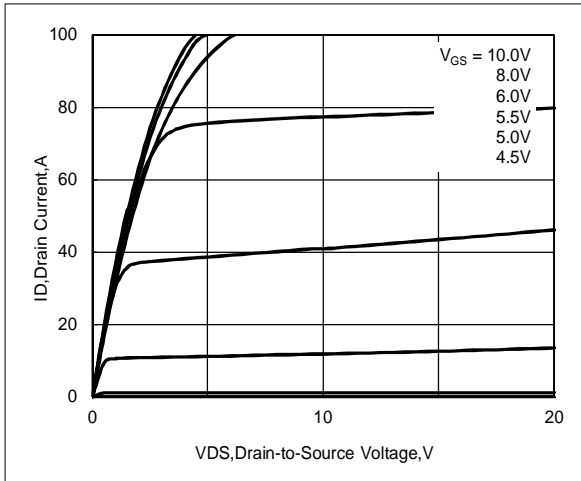

Figure 1. Output Characteristics

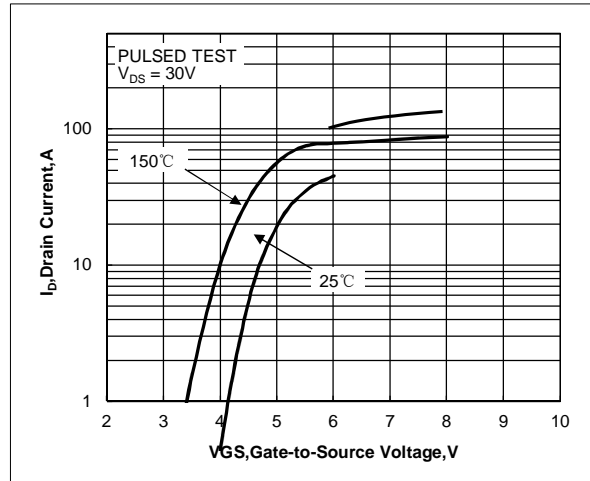

Figure 2. Transfer Characteristics

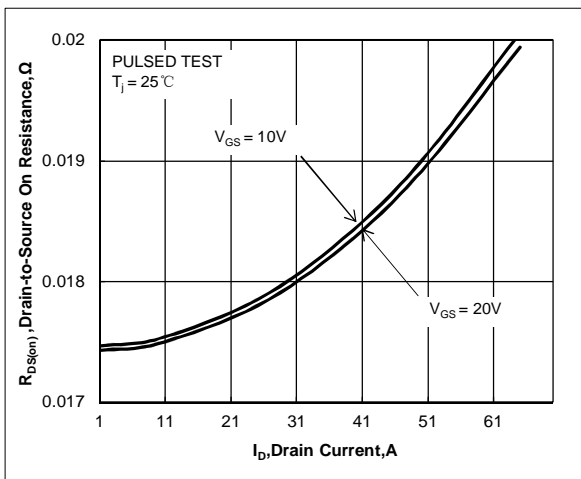

Figure 3. Drain-to-Source On Resistance vs. Drain Current and Gate Voltage

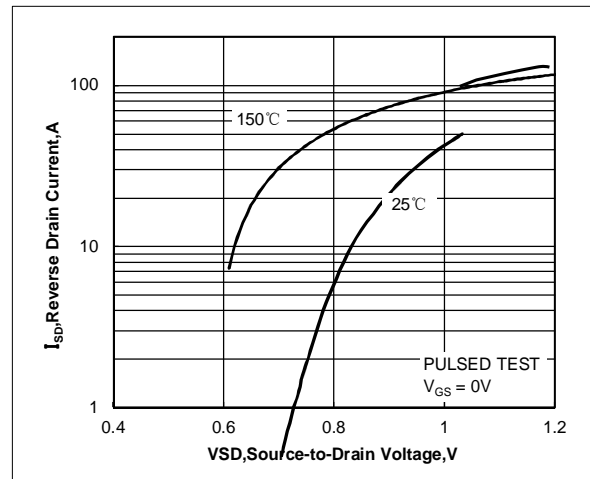

Figure 4. Body Diode Forward Voltage vs. Source Current and Temperature

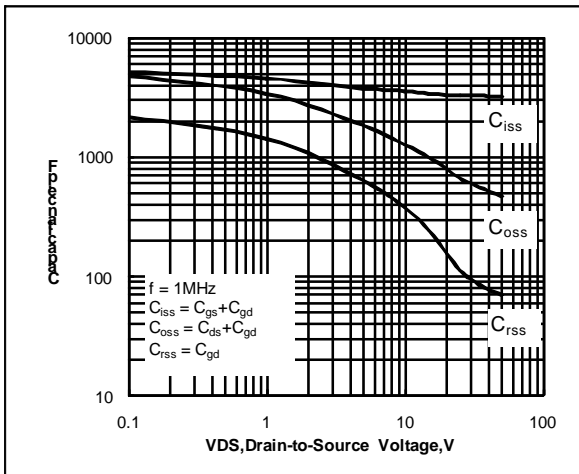

Figure 5. Capacitance Characteristics

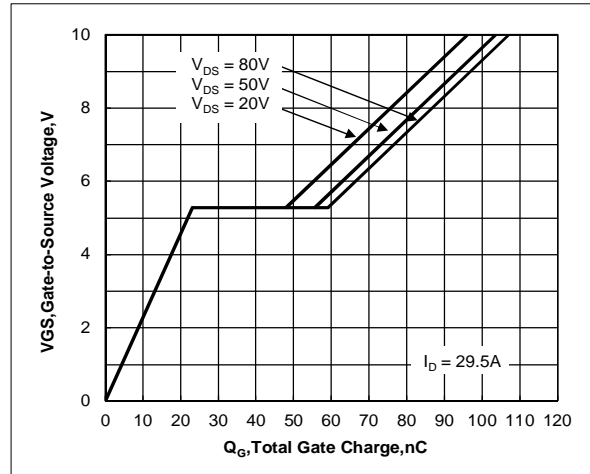

Figure 6. Gate Charge Characteristics

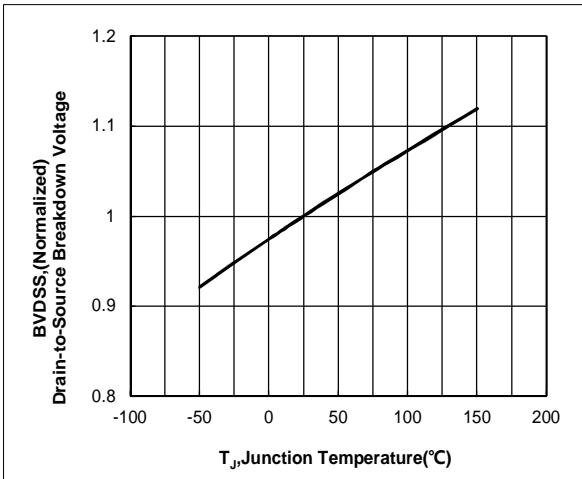

Figure 7. Normalized Breakdown Voltage vs. Junction Temperature

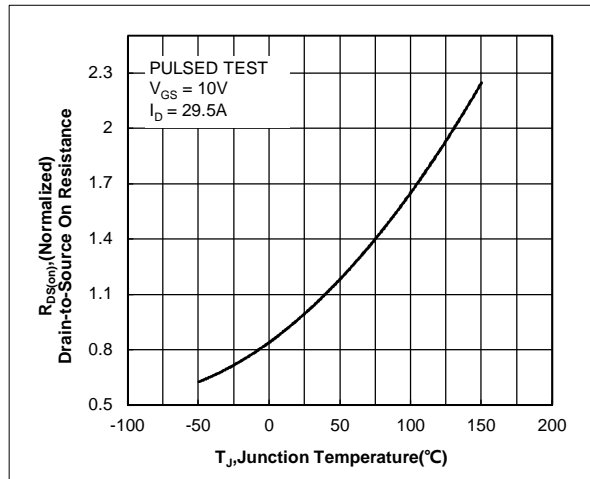

Figure 8. Normalized On Resistance vs. Junction Temperature

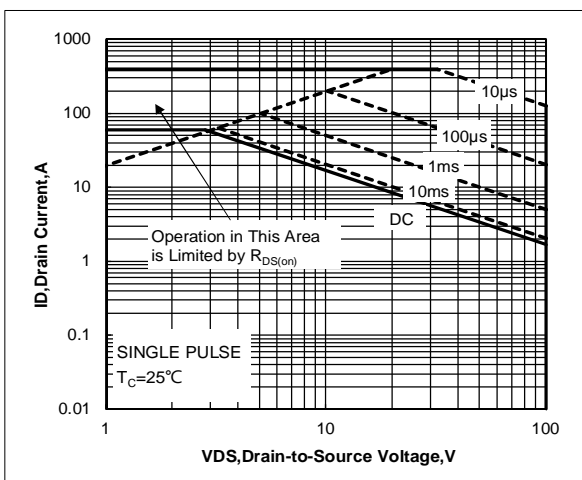

Figure 9. Maximum Safe Operating Area for OP3710A

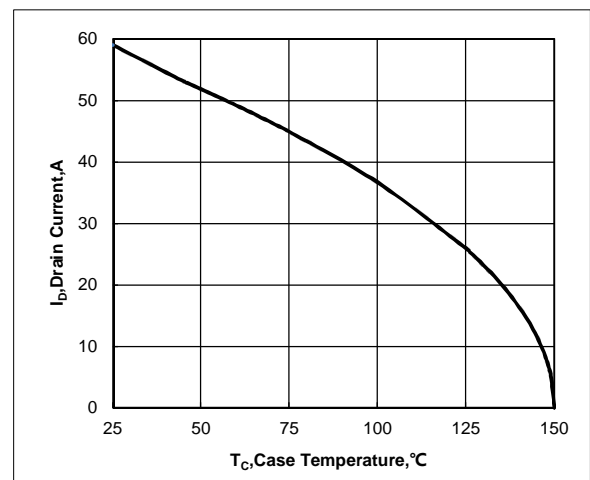

Figure 10. Maximum Continuous Drain Current vs. Case Temperature

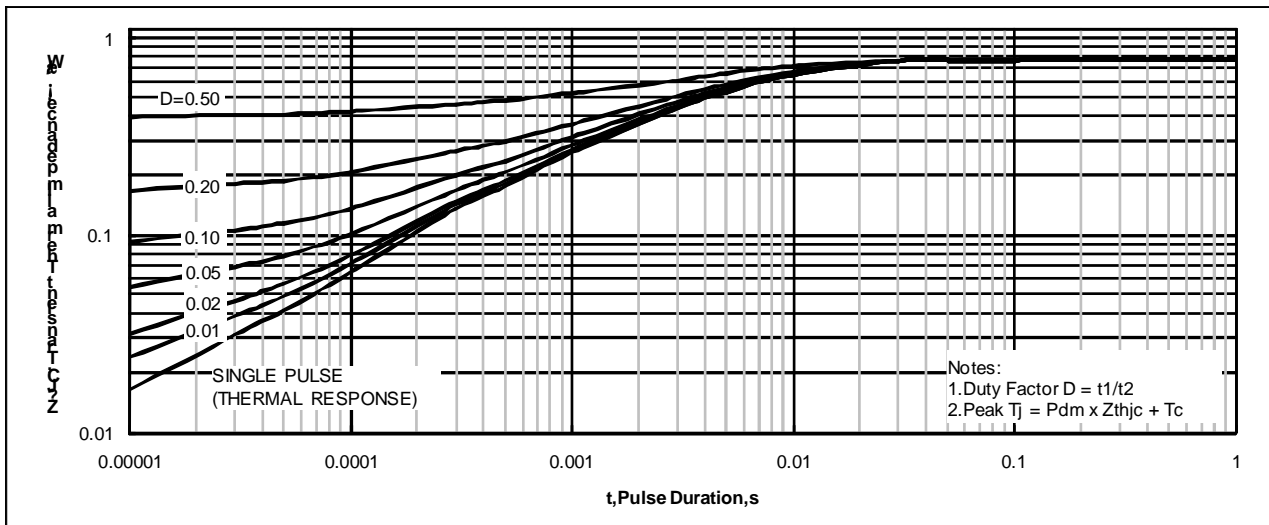

Figure 11. Maximum Effective Transient Thermal Impedance, Junction-to-Case for OP3710A

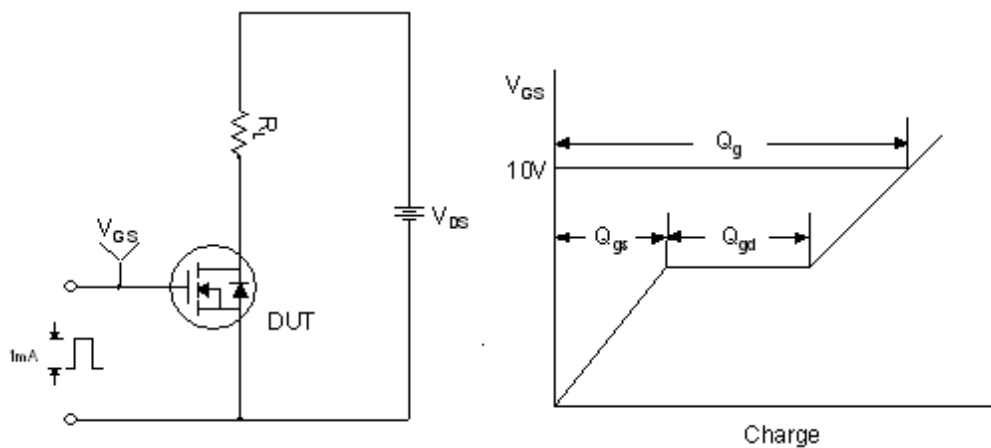

Figure 12. Gate Charge Test Circuit & Waveform

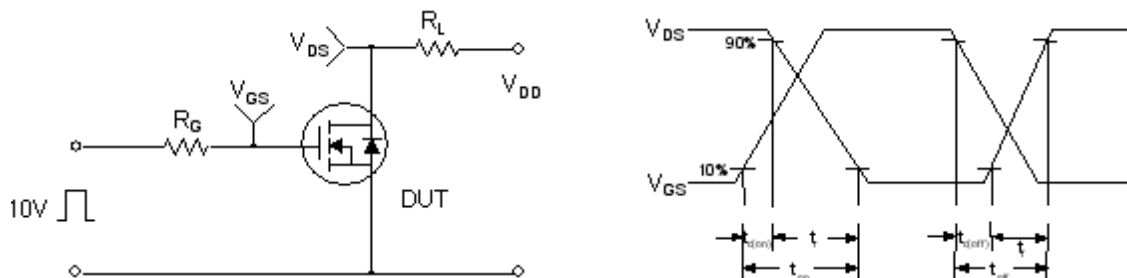

Figure 13. Resistive Switching Test Circuit & Waveforms

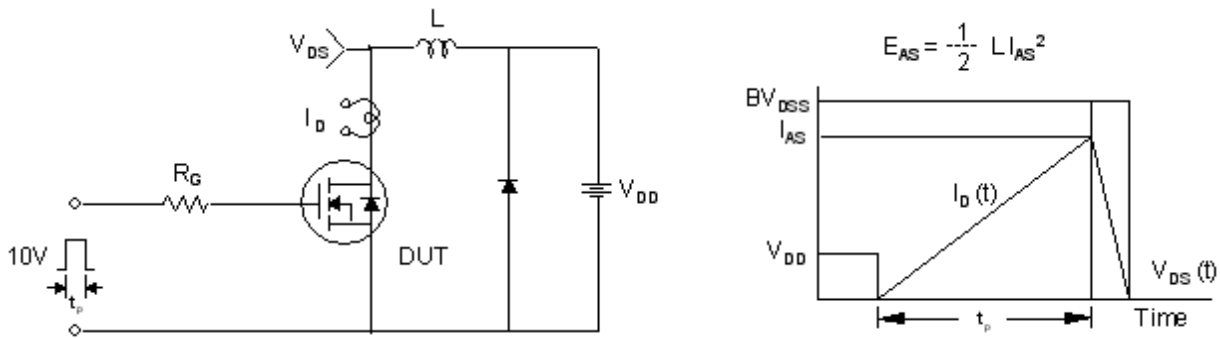
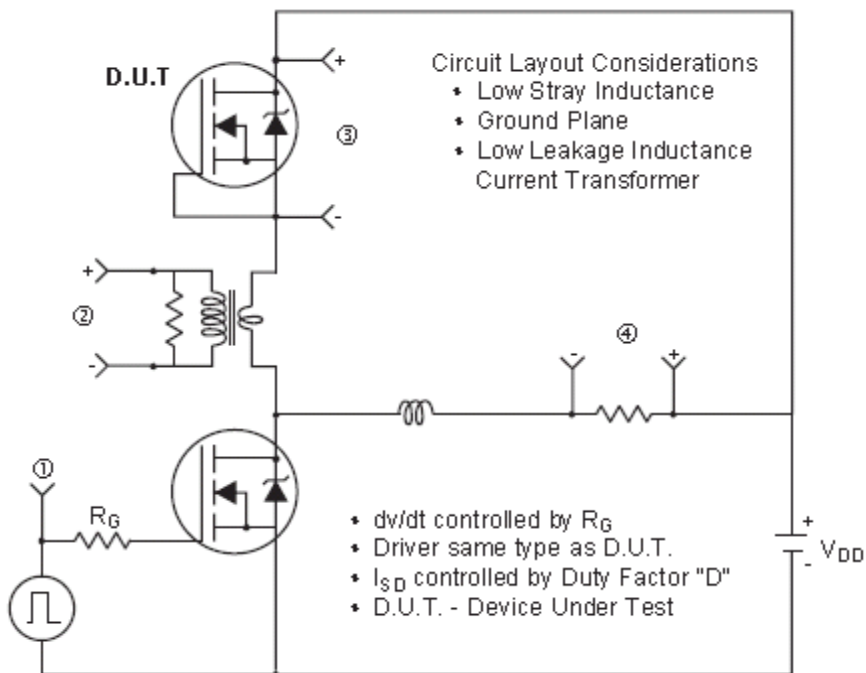

Figure 14. Unclamped Inductive Switching Test Circuit & Waveforms



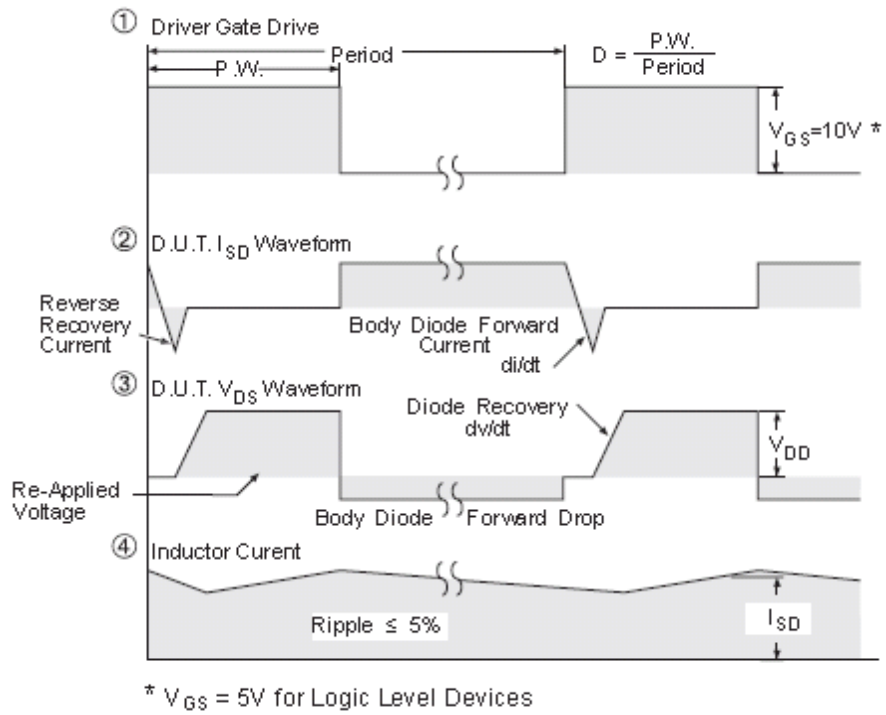

Figure 15. Peak Diode Recovery  $dv/dt$  Test Circuit & Waveforms (For N-channel)

## **Disclaimers:**

GOFORD has made reasonable commercial efforts to ensure that the information given in this data sheet is correct. However, it must clearly be understood that such information is for guidance only and does not constitute any representation or form part of any offer or contract.

For documents and material available from this data sheet, GOFORD does not warrant or assume any legal liability or responsibility for the accuracy, completeness, or usefulness of any information, product, technology or process disclosed hereunder.

GOFORD reserves the rights to at its own discretion to make any changes or improvements to this data sheet. Unless said data sheet is incorporated into the formal contract, any customer should not rely on the information as any specification or product parameters duly committed by GOFORD. Customers are hereby advised to verify that the information contained herein is current and complete before the entering of any contract or acknowledgement of any purchase order. Accordingly, all products specified hereunder shall be sold subject to GOFORD's terms and conditions supplied at the time of order acknowledgement. Except where agreed upon by contractual agreement, testing of all parameters of each product is not necessarily performed.

GOFORD does not warrant or convey any license either expressed or implied under its patent rights, nor the rights of others. Reproduction of information contained herein shall be only permissible if such reproduction is without any modification or alteration. Reproduction of this information with any alteration is an unfair and deceptive business practice. GOFORD is not responsible or liable for such altered documentation.

Resale of GOFORD's products with statements different from or beyond the parameters stated by GOFORD for that product or service voids all express or implied warranties for the associated GOFORD's product or service and is unfair and deceptive business practice. GOFORD is not responsible or liable for any such statements.

GOFORD's products are not authorized for use as critical components in life support devices or systems without the express written approval of GOFORD. As used herein:

1. Life support devices or systems are devices or systems which, (a) are intended for surgical implant into the body, or (b) support or sustain life, and whose failure to perform, when properly used in accordance with instructions for use provided in the labeling, can be reasonably expected to result in a significant injury to the user.
2. A critical component is any component of a life support device or system whose failure to perform can be reasonably expected to cause the failure of the life support device or system, or to affect its safety or effectiveness.