

Technical Data Sheet

Full Color Side View LEDs (Height 0.8mm)

99-235/RSGBB7C-A22/2D

Features

- White package.
- Optical indicator.
- Colorless clear window.
- Ideal for backlight and light pipe application.
- Inter reflector.
- Wide viewing angle.
- Suitable for vapor-phase reflow, Infrared reflow and wave solder processes.
- Computable with automatic placement equipment.
- Available on tape and reel (12mm Tape)
- Pb-free
- The product itself will remain within RoHS compliant version.



Descriptions

- The 99-235 series is available in soft red, green and blue.
Due to the package design, the LED has wide viewing angle and optimized light coupling by inter reflector. This feature makes the ideal for light pipe application. The low current requirement makes this device ideal for portable equipment or any other application where power is at a premium.

Applications

- Telecommunication: indicator and backlighting in telephone and fax.
- Flat backlight for LCD's, switches and symbols.
- Light pipe application.
- General use.

Device Selection Guide

| Chip | | | Resin Color |
|------|----------|-----------------|-------------|
| Type | Material | Emitted Color | |
| RS | AlGaInP | Brilliant Red | Water Clear |
| GB | InGaN | Brilliant Green | |
| B7 | InGaN | Blue | |

Technical Data Sheet

Full Color Side View LEDs (Height 0.8mm)

99-235/RSGBB7C-A22/2D

Package Outline Dimensions

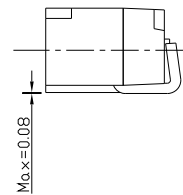
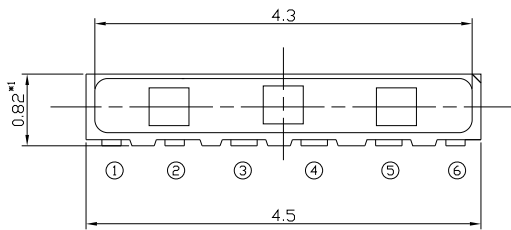
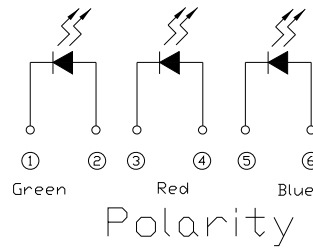
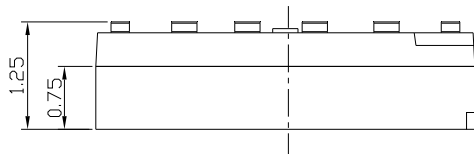

Recommended soldering pad design

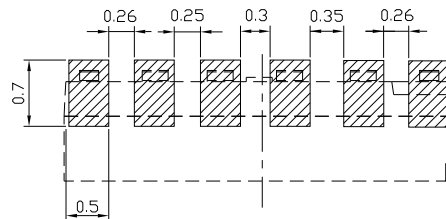
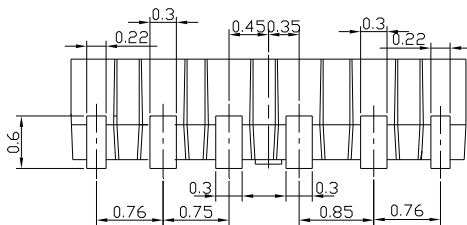

Note: The tolerances unless mentioned is $\pm 0.1\text{mm}$;Unit = mm

Technical Data Sheet

Full Color Side View LEDs (Height 0.8mm)

99-235/RSGBB7C-A22/2D

Absolute Maximum Ratings (Ta=25°C)

| Parameter | Symbol | | Rating | Unit |
|--|-----------------|----|---|------|
| Reverse Voltage | V _R | | 5 | V |
| Forward Current | I _F | RS | 50 | mA |
| | | GB | 30 | |
| | | B7 | 30 | |
| Peak Forward Current(Duty 1/10@ 1KHZ) | I _{FP} | RS | 100 | mA |
| | | GB | 100 | |
| | | B7 | 100 | |
| Power Dissipation | Pd | RS | 130 | mW |
| | | GB | 110 | |
| | | B7 | 110 | |
| Electrostatic Discharge(HBM) | ESD | RS | 2000 | V |
| | | GB | 2000 | |
| | | B7 | 2000 | |
| Operating Temperature | Topr | | -40 ~ +85 | °C |
| Storage Temperature | Tstg | | -40~ +90 | °C |
| Soldering Temperature | Tsol | | Reflow Soldering : 260 °C for 10 sec. Hand Soldering : 350 °C for 3 sec. | |

Technical Data Sheet
Full Color Side View LEDs (Height 0.8mm)
99-235/RSGBB7C-A22/2D
Electro-Optical Characteristics (Ta=25°C)

| Parameter | Symbol | | Min. | Typ. | Max. | Unit | Condition |
|------------------------|----------------|-------|-------|-------|-------|-------|---|
| Luminous Intensity | I _v | RS | 225 | ----- | 450 | mcd | I _F =17mA (R) I _F =18mA (G) I _F =9mA (B) |
| | | GB | 565 | ----- | 1120 | | |
| | | B7 | 57 | ----- | 140 | | |
| Viewing Angle | 2θ 1/2 | | ----- | 120 | ----- | deg | |
| Dominant Wavelength | λ _d | RS | 618 | ----- | 627 | nm | |
| | | GB | 525 | ----- | 535 | | |
| | | B7 | 457 | ----- | 465 | | |
| Forward Voltage | V _F | RS | 1.80 | ----- | 2.30 | V | |
| | | GB | 2.75 | ----- | 3.45 | | |
| | | B7 | 2.75 | ----- | 3.45 | | |
| White point coordinate | x | ----- | ----- | 0.294 | ----- | ----- | |
| | y | ----- | ----- | 0.286 | ----- | ----- | |
| Reverse Current | I _R | RS | ----- | ----- | 10 | μA | V _R =5V |

Notes:

1. Tolerance of Luminous Intensity ±11%
2. Tolerance of Dominant Wavelength ±1nm
3. Tolerance of Forward Voltage : ±0.1V

Bin Range of Luminous Intensity

Technical Data Sheet

Full Color Side View LEDs (Height 0.8mm)

99-235/RSGBB7C-A22/2D

| Symbol | | Bin Code | Min. | Max. | Unit | Condition |
|----------------|----|----------|------|------|------|---|
| I _v | RS | S2 | 225 | 285 | mcd | I _F =17mA (R) I _F =18mA (G) I _F =9mA (B) |
| | | T1 | 285 | 360 | | |
| | | T2 | 360 | 450 | | |
| | GB | U2 | 565 | 715 | | |
| | | V1 | 715 | 900 | | |
| | | V2 | 900 | 1120 | | |
| | B7 | P2 | 57 | 72 | | |
| | | Q1 | 72 | 90 | | |
| | | Q2 | 90 | 112 | | |
| | | R1 | 112 | 140 | | |

Bin Range of Forward Voltage

| Symbol | | Bin Code | Min. | Max. | Unit | Condition |
|----------------|----|----------|------|------|------|---|
| V _F | RS | RV1 | 1.80 | 2.05 | V | I _F =17mA (R) I _F =18mA (G) I _F =9mA (B) |
| | | RV2 | 2.05 | 2.30 | | |
| | GB | GV1 | 2.75 | 3.10 | | |
| | | GV2 | 3.10 | 3.45 | | |
| | B7 | BV1 | 2.75 | 3.10 | | |
| | | BV2 | 3.10 | 3.45 | | |

Note:

1. Tolerance of Luminous Intensity: $\pm 11\%$
2. Tolerance of Forward Voltage: $\pm 0.1V$

Technical Data Sheet

Full Color Side View LEDs (Height 0.8mm)

99-235/RSGBB7C-A22/2D

Bin Code of Chromaticity Coordinates

R/G/B=17/18/9mA

| Bin Code | CIE_x | CIE_y | Bin Code | CIE_x | CIE_y |
|----------|-------|-------|----------|-------|-------|
| S1 | 0.284 | 0.276 | S2 | 0.304 | 0.276 |
| | 0.284 | 0.296 | | 0.304 | 0.296 |
| | 0.304 | 0.296 | | 0.324 | 0.296 |
| | 0.304 | 0.276 | | 0.324 | 0.276 |
| S3 | 0.304 | 0.296 | S4 | 0.284 | 0.296 |
| | 0.304 | 0.316 | | 0.284 | 0.316 |
| | 0.324 | 0.316 | | 0.304 | 0.316 |
| | 0.324 | 0.296 | | 0.304 | 0.296 |
| S5 | 0.264 | 0.296 | S6 | 0.264 | 0.276 |
| | 0.264 | 0.316 | | 0.264 | 0.296 |
| | 0.284 | 0.316 | | 0.284 | 0.296 |
| | 0.284 | 0.296 | | 0.284 | 0.276 |
| S7 | 0.264 | 0.256 | S8 | 0.284 | 0.256 |
| | 0.264 | 0.276 | | 0.284 | 0.276 |
| | 0.284 | 0.276 | | 0.304 | 0.276 |
| | 0.284 | 0.256 | | 0.304 | 0.256 |
| S9 | 0.304 | 0.256 | | | |
| | 0.304 | 0.276 | | | |
| | 0.324 | 0.276 | | | |
| | 0.324 | 0.256 | | | |

Note:

Tolerance of Chromaticity Coordinates: ± 0.01

Technical Data Sheet

Full Color Side View LEDs (Height 0.8mm)

99-235/RSGBB7C-A22/2D

The C.I.E. 1931 Chromaticity Diagram

R/G/B=17/18/9mA

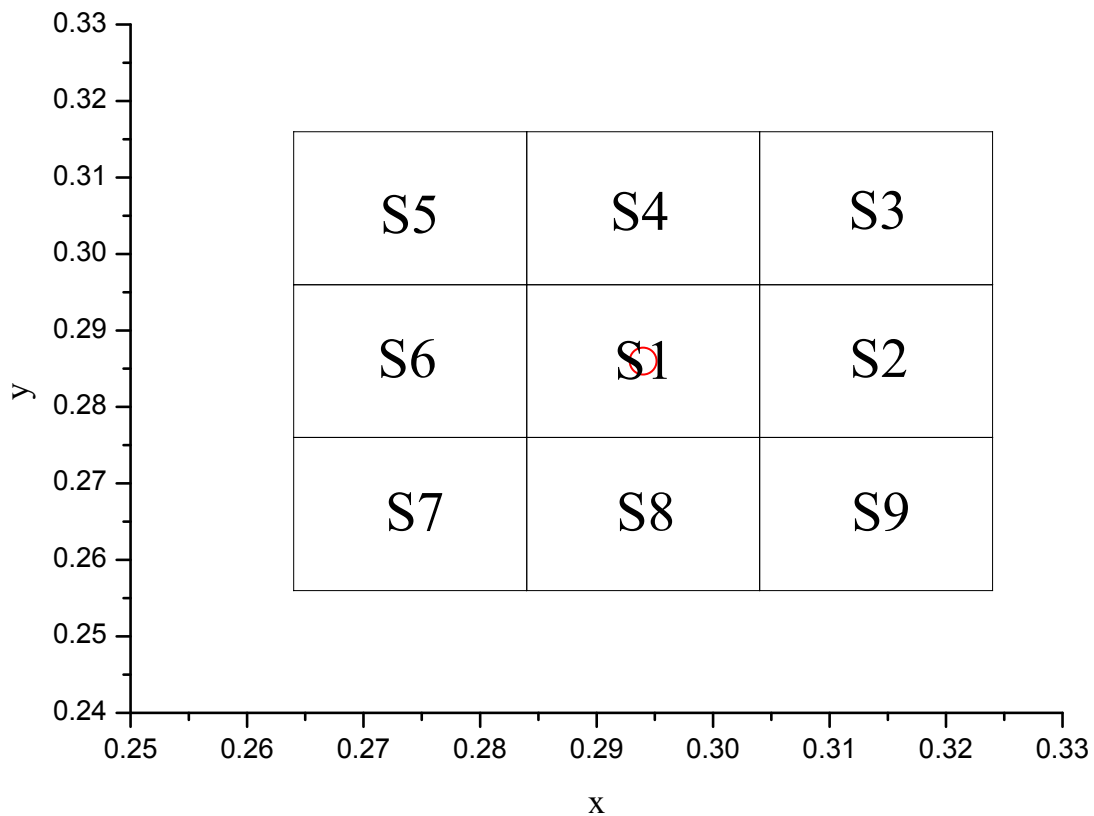

Technical Data Sheet

Full Color Side View LEDs (Height 0.8mm)

99-235/RSGBB7C-A22/2D

Typical Electro-Optical Characteristics Curves(RS)

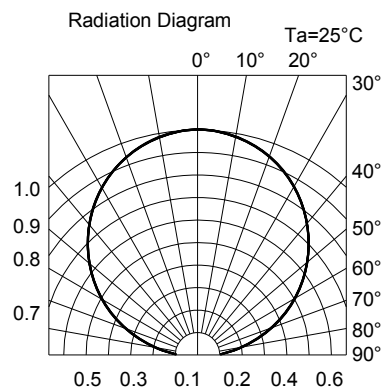
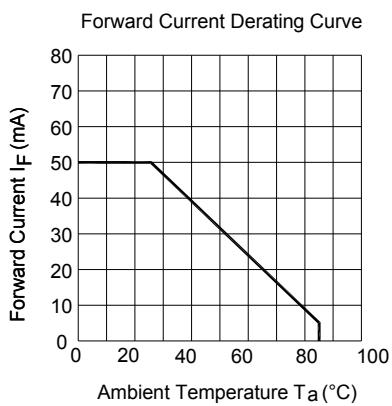
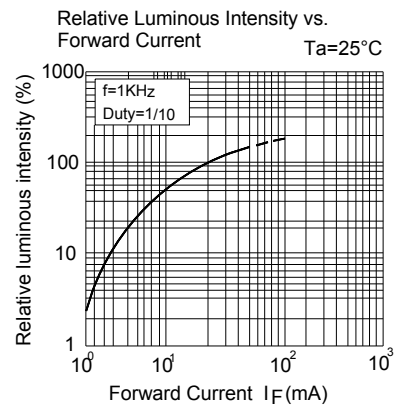
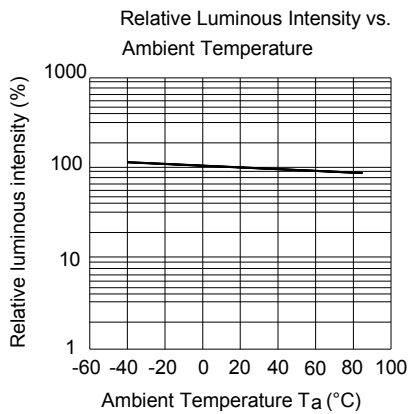
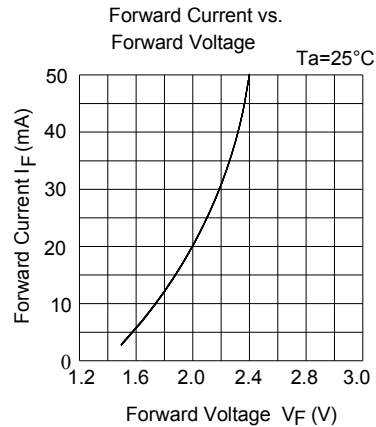
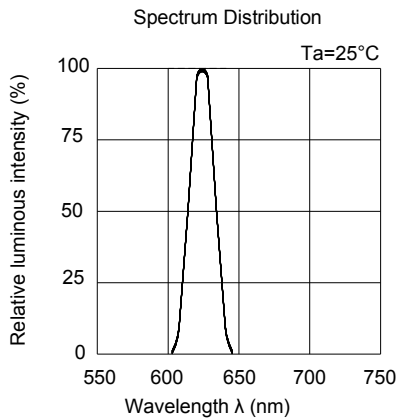

Technical Data Sheet

Full Color Side View LEDs (Height 0.8mm)

99-235/RSGBB7C-A22/2D

Typical Electro-Optical Characteristics Curves(GB)

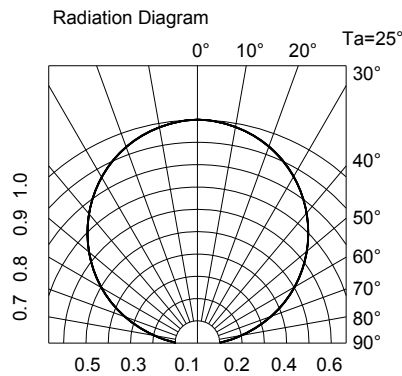
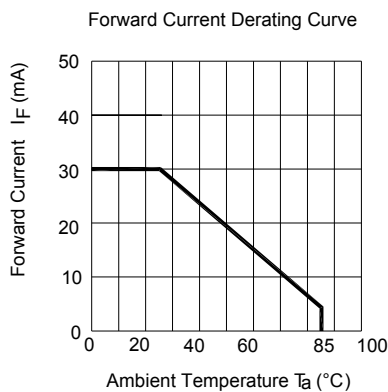
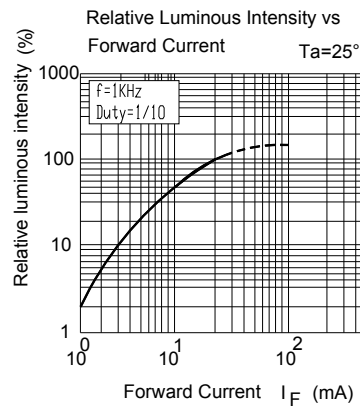
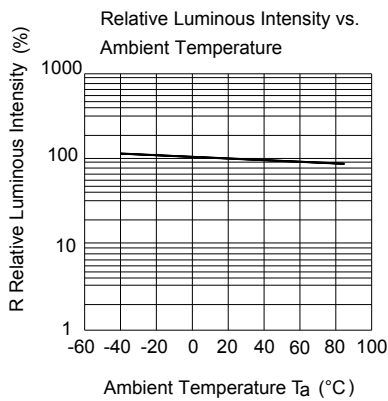
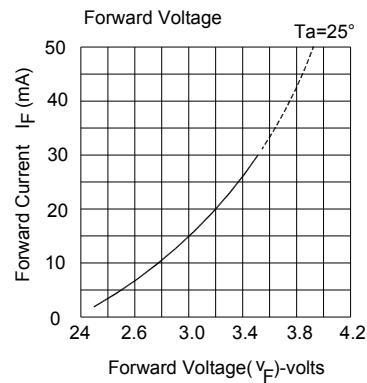
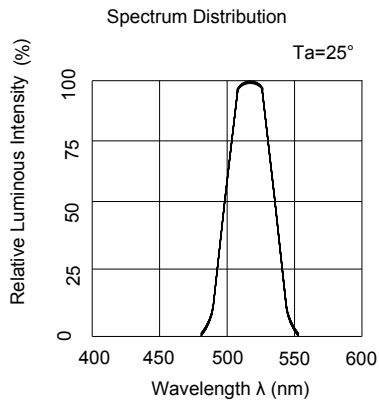

Technical Data Sheet

Full Color Side View LEDs (Height 0.8mm)

99-235/RSGBB7C-A22/2D

Typical Electro-Optical Characteristics Curves(B7)

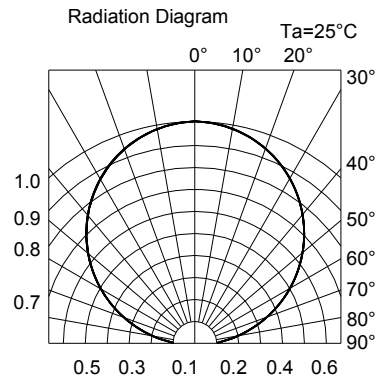
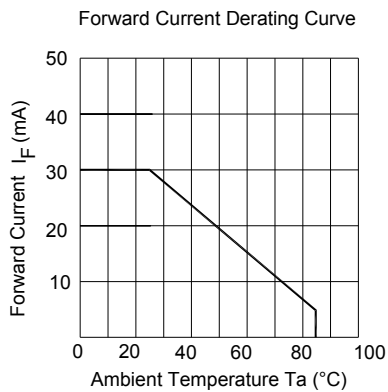
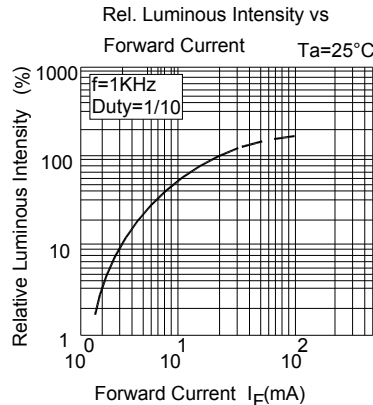
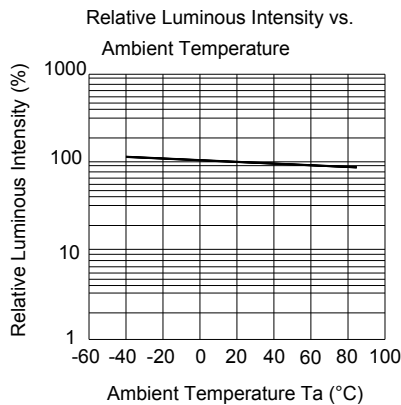
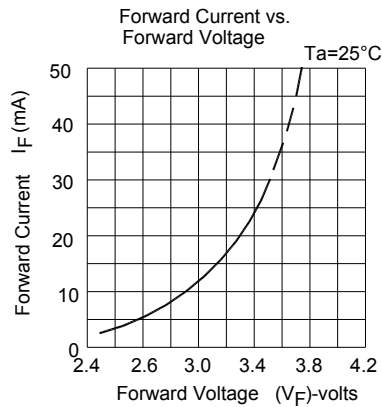
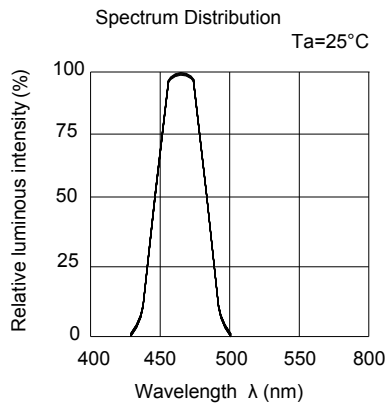

Technical Data Sheet

Full Color Side View LEDs (Height 0.8mm)

99-235/RSGBB7C-A22/2D

Label Explanation

CAT: Luminous Intensity Rank

HUE: Chromaticity Coordinates

REF: Forward Voltage Rank



Reel Dimensions

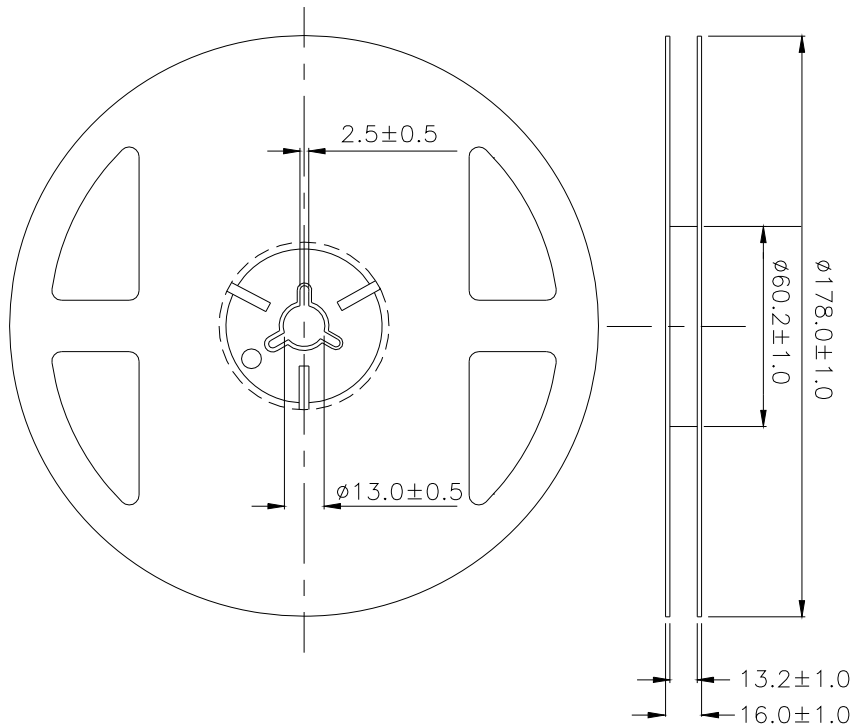

Note: The tolerances unless mentioned is ± 0.1 mm ;Unit = mm

Technical Data Sheet

Full Color Side View LEDs (Height 0.8mm)

99-235/RSGBB7C-A22/2D

Carrier Tape Dimensions: Loaded quantity 2000 PCS per reel.

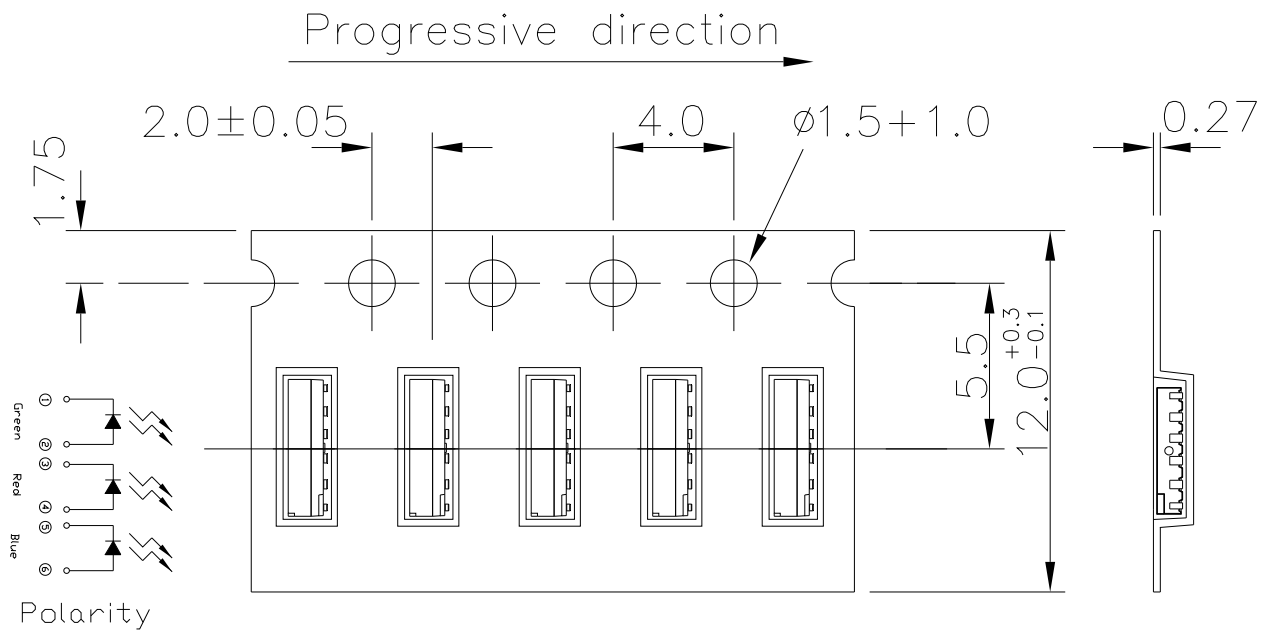

Note: The tolerances unless mentioned is ±0.1mm ;Unit = mm

Moisture Resistant Packaging

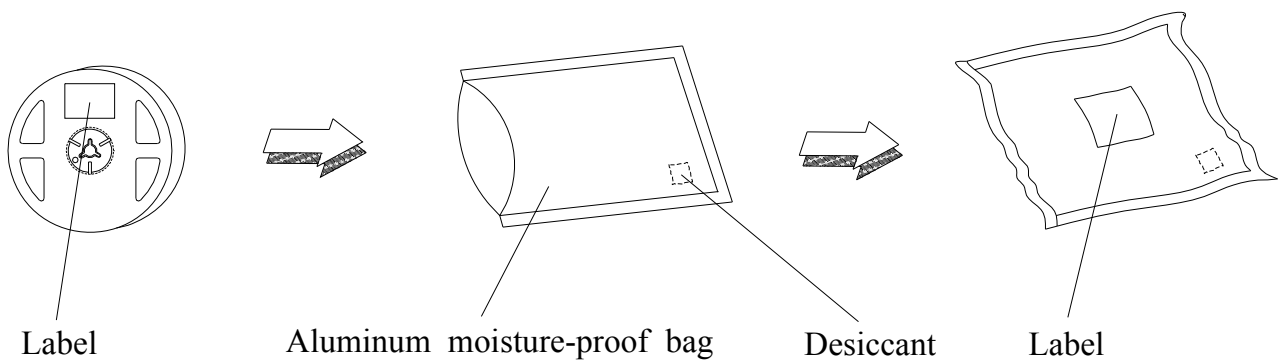

Technical Data Sheet
Full Color Side View LEDs (Height 0.8mm)
99-235/RSGBB7C-A22/2D
Reliability Test Items And Conditions

The reliability of products shall be satisfied with items listed below.

Confidence level : 90%

LTPD : 10%

| No. | Items | Test Condition | Test Hours/Cycles | Sample Size | Ac/Re |
|-----|----------------------------------|--|-------------------|-------------|-------|
| 1 | Reflow Soldering | Temp. : 260°C±5°C Max. 10sec. | 6 min | 22 PCS. | 0/1 |
| 2 | Temperature Cycle | H : +100°C 15min ∫ 5 min L : -40°C 15min | 300 Cycles | 22 PCS. | 0/1 |
| 3 | Thermal Shock | H : +100°C 5min ∫ 10 sec L : -10°C 5min | 300 Cycles | 22 PCS. | 0/1 |
| 4 | High Temperature Storage | Temp. : 100°C | 1000 Hrs. | 22 PCS. | 0/1 |
| 5 | Low Temperature Storage | Temp. : -40°C | 1000 Hrs. | 22 PCS. | 0/1 |
| 6 | DC Operating Life | I _F = 20 mA | 1000 Hrs. | 22 PCS. | 0/1 |
| 7 | High Temperature / High Humidity | 85°C/RH85% | 1000 Hrs. | 22 PCS. | 0/1 |

Technical Data Sheet

Full Color Side View LEDs (Height 0.8mm)

99-235/RSGBB7C-A22/2D

Precautions For Use

1. Over-current-proof

Customer must apply resistors for protection, otherwise slight voltage shift will cause big current change (Burn out will happen).

2. Storage

2.1 Do not open moisture proof bag before the products are ready to use.

2.2 Before opening the package: The LEDs should be kept at 30°C or less and 90%RH or less.

2.3 After opening the package: The LED's floor life are 168 hours under 30°C or less and 60% RH or less.If unused LEDs remain, it should be stored in moisture proof packages.

2.4 If the moisture absorbent material (silica gel) has faded away or the LEDs have exceeded the storage time, baking treatment should be performed using the following conditions.
Baking treatment : 60±5°C for 24 hours.

3. Soldering Condition

3.1 Pb-free solder temperature profile

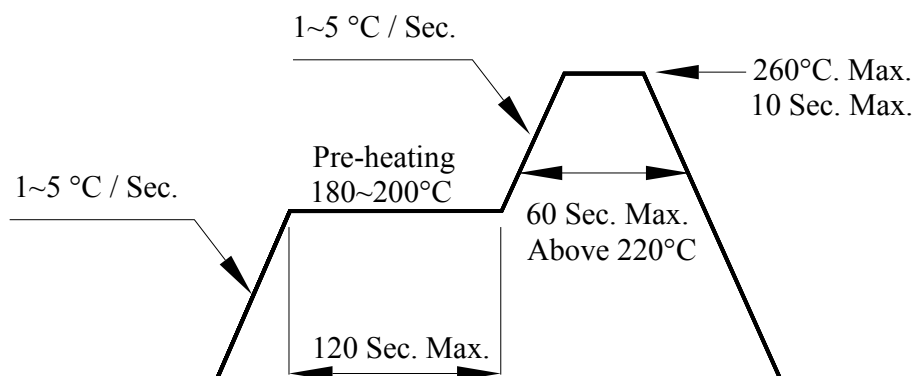

3.2 Reflow soldering should not be done more than two times.

3.3 When soldering, do not put stress on the LEDs during heating.

3.4 After soldering, do not warp the circuit board.

4. Soldering Iron

Each terminal is to go to the tip of soldering iron temperature less than 350°C for 3 seconds within once in less than the soldering iron capacity 25W. Leave two seconds and more intervals, and do soldering of each terminal. Be careful because the damage of the product is often started at the time of the hand solder.

Technical Data Sheet

Full Color Side View LEDs (Height 0.8mm)

99-235/RSGBB7C-A22/2D

5. Repairing

Repair should not be done after the LEDs have been soldered. When repairing is unavoidable, a double-head soldering iron should be used (as below figure). It should be confirmed beforehand whether the characteristics of the LEDs will or will not be damaged by repairing.

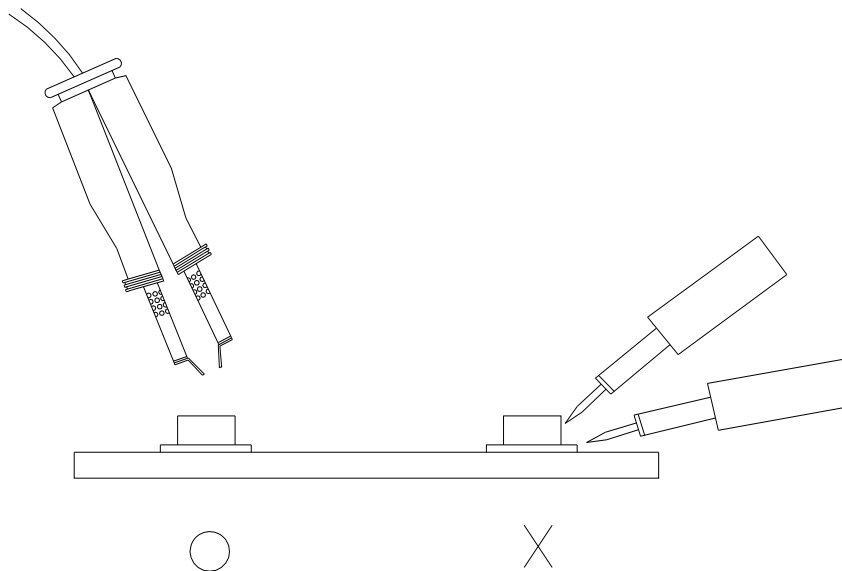

EVERLIGHT ELECTRONICS CO., LTD.
Office: No 25, Lane 76, Sec 3, Chung Yang Rd,
Tucheng, Taipei 236, Taiwan, R.O.C

Tel: 886-2-2267-2000, 2267-9936
Fax: 886-2267-6244, 2267-6189, 2267-6306
<http://www.everlight.com>