

Recommended P/N		20728-0**T-01							
PART NO.	Pos.	A	B	C	D	E	F	G	
20728-030T-01	30	18.89	15.86	13.60	12.80	5.60	18.60	20.05	
20728-040T-01	40	22.89	19.86	17.60	16.80	7.60	22.60	24.05	

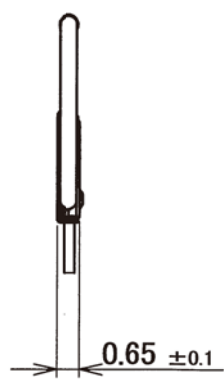
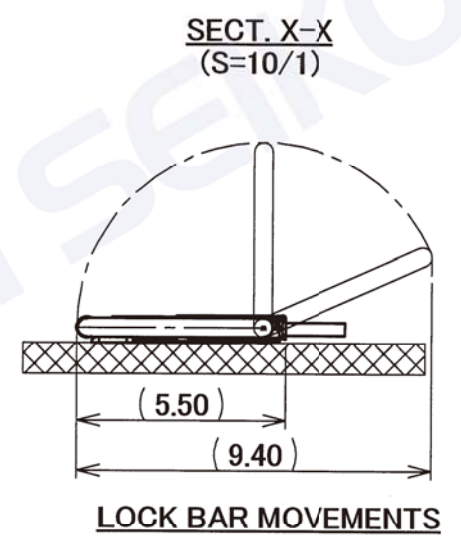
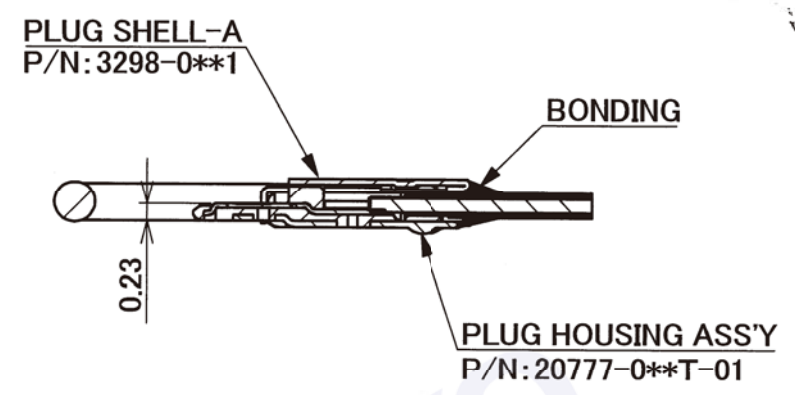
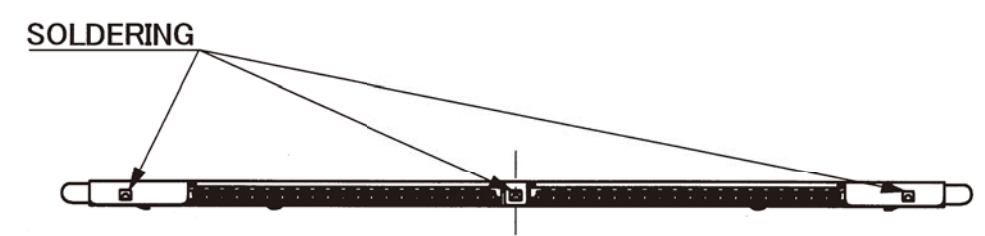
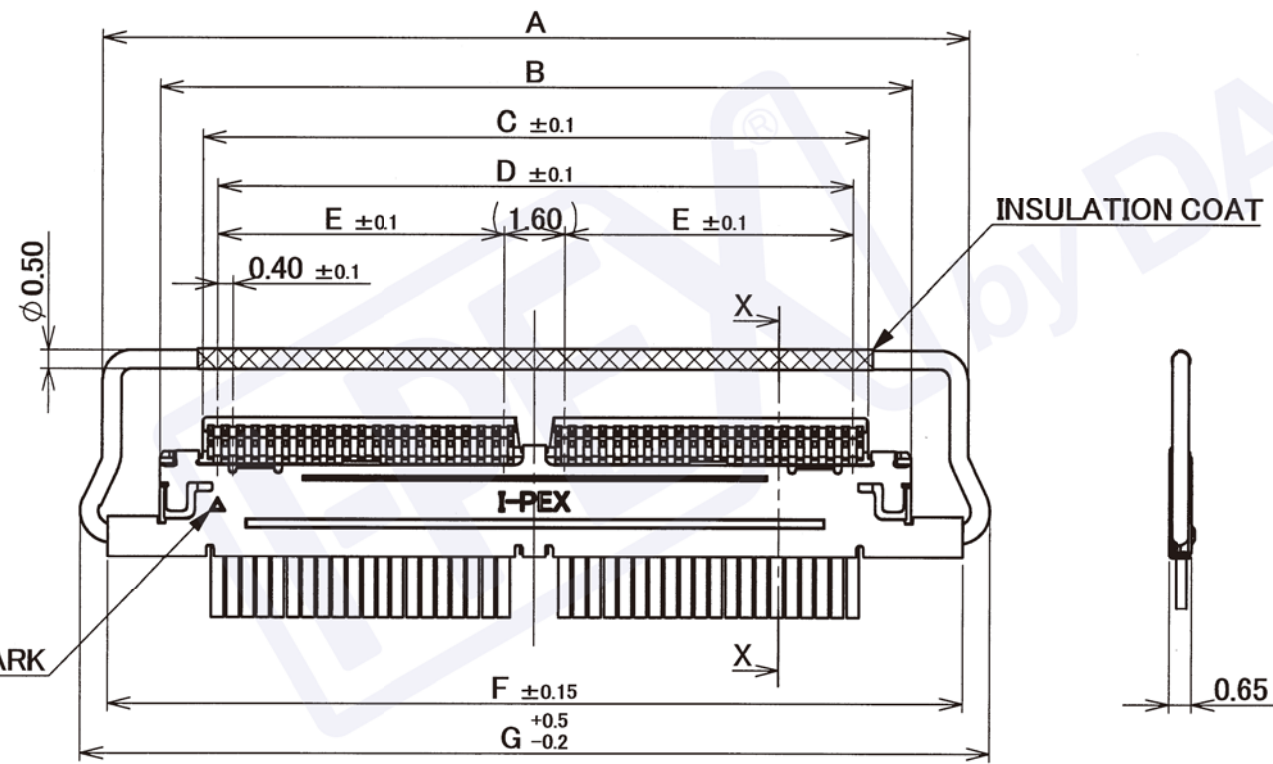
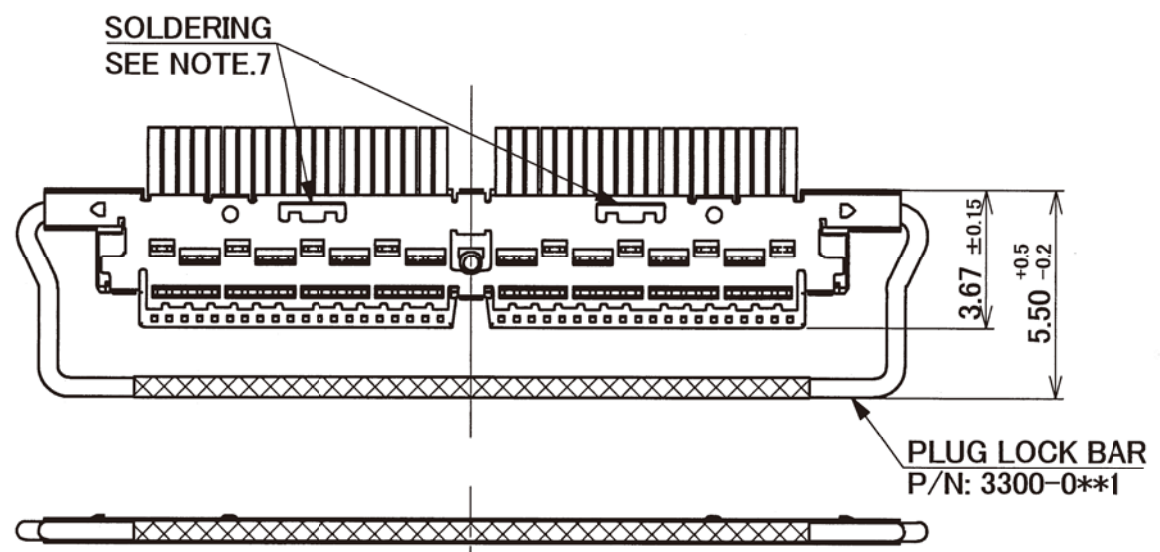

- NOTES.
- MATERIAL & FINISH
 HOUSING : HEAT RESISTING PLASTICS (RED PHOSPHORUS FREE), UL94V-0, BLACK
 CONTACT : COPPER ALLOY / Au OVER Ni
 SHELL A : COPPER ALLOY / Ni
 SHELL B : COPPER ALLOY / Ni
 LOCK BAR : SUS
 - PRODUCT SPECIFICATION : DOCUMENT No. PRS-2371
 INSTRUCTION MANUAL : DOCUMENT No. HIM-17010
 ASSEMBLY MANUAL : DOCUMENT No. ASM-17003
 - RECOMMENDED CABLE
 MICRO-COAX : AWG#40, 42, 44
 DISCRETE : AWG#34, 36
 - RoHS COMPLIANT: THIS PRODUCT IS COMPLIANT WITH RoHS DIRECTIVE.
 - HALOGEN FREE: THIS PRODUCT IS CONFORMED TO IEC 61249-2-21.
 - SOLDERING IS ONLY A CASE WITH GND-BAR.

GENERAL TOLERANCE	
6 MAX.	±0.2
6 OVER MAX. 30	±0.3
30 OVER MAX. 120	±0.5
ANGLE	±2°

I-PEX DAI-ICHI SEIKO CO.,LTD.
I-PEX Business Company

TITLE
CABLNE-CAL
PLUG FOR CABLE ASS'Y

CUSTOMER COPY	PROJECTION	SCALE	UNIT	DWG. No.	SHEET	REV.
		5:1	mm	20728	1/2	0

Confidential C

Recommended P/N 20728-0T-01**

PART NO.	Pos.	A	B
20728-030E-0#	30	12.80	5.60
20728-040E-0#	40	16.80	7.60

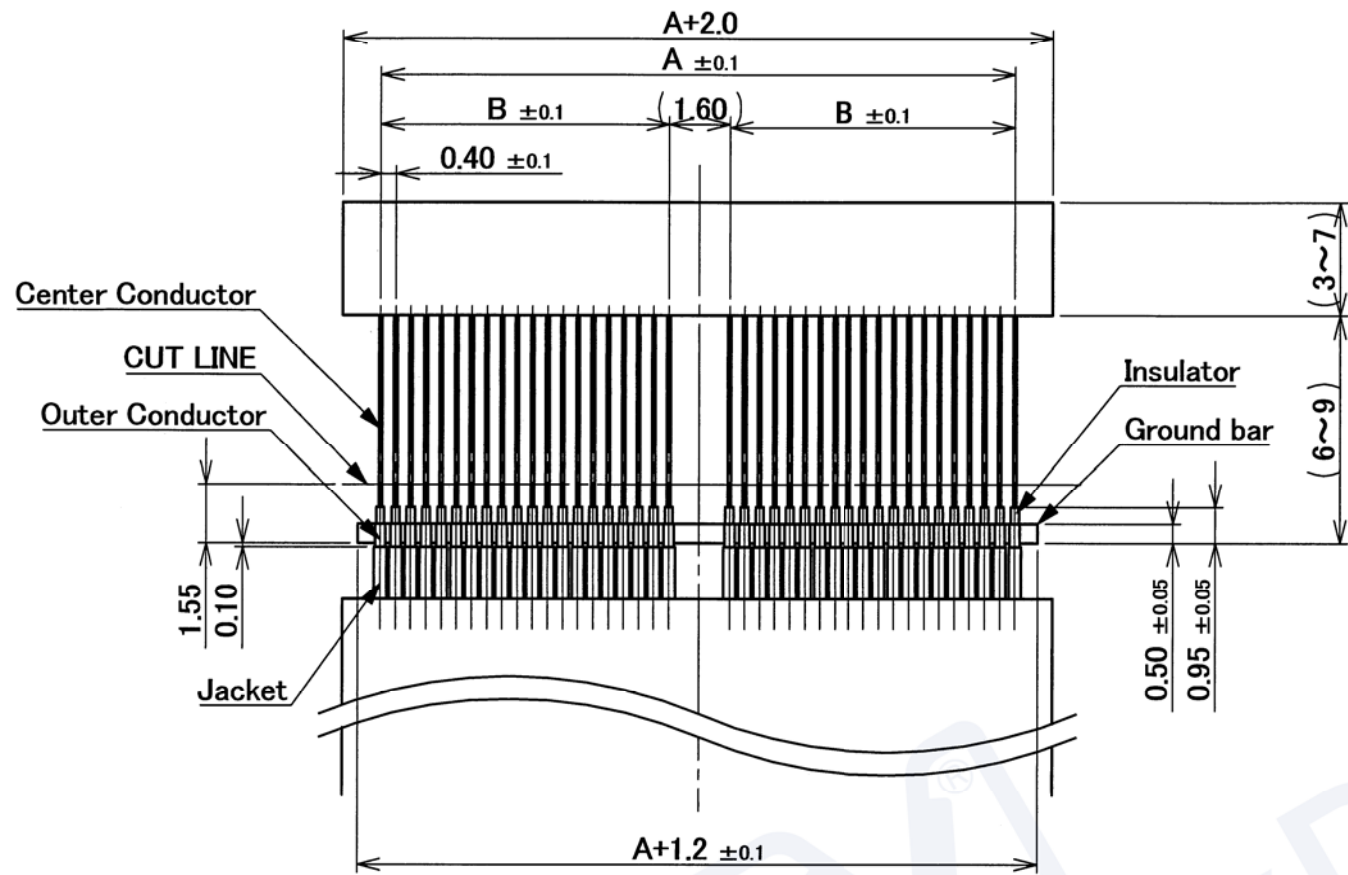

RECOMMENDED MICRO-COAX CABLE
AWG #**

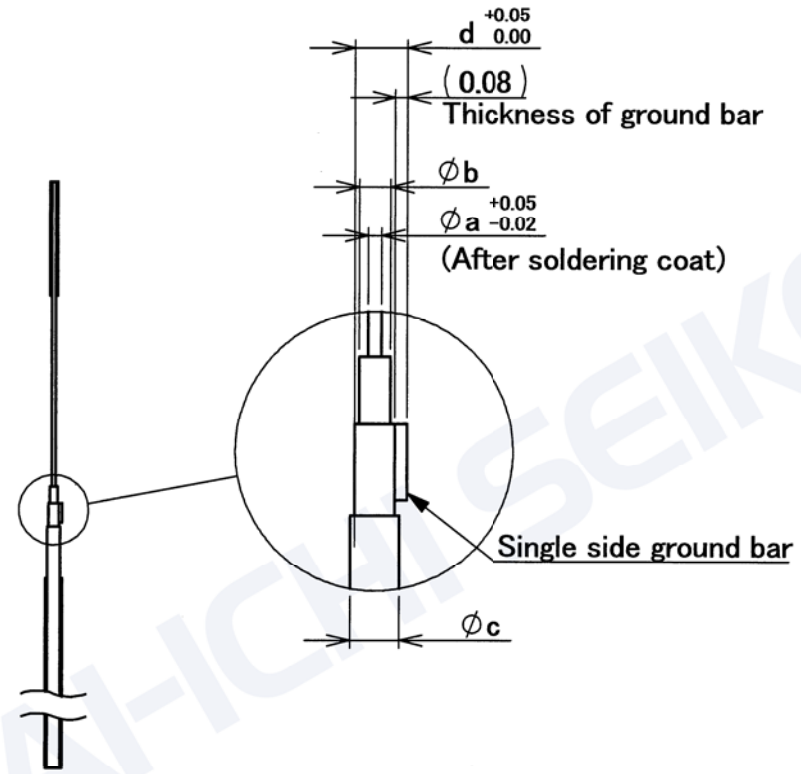

MICRO-COAX DIMENSION

	a	b	c	d
#40	0.09	0.21	0.33	0.35
#42	0.075	0.20	0.28	0.34
#44	0.063	0.18	0.26	0.32

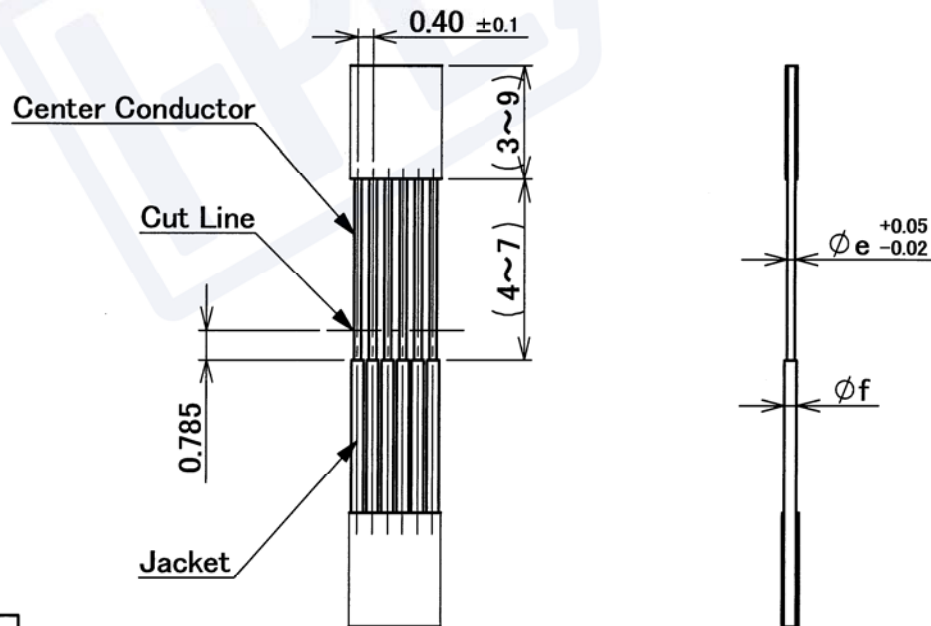

RECOMMENDED DISCRETE CABLE
AWG #**

DISCRETE DIMENSION

	e	f
#34	0.192	0.32
#36	0.15	0.25

GENERAL TOLERANCE	
6 MAX.	±0.2
6 OVER MAX. 30	±0.3
30 OVER MAX. 120	±0.5
ANGLE	±2°

I-PEX DAI-ICHI SEIKO CO.,LTD.
I-PEX Business Company

TITLE
**CABLIXE-CAL
PLUG FOR CABLE ASS'Y**

CUSTOMER COPY	PROJECTION	SCALE	UNIT	DWG. No.	SHEET	REV.
		10:1	mm	20728	2/2	0