

High Accuracy Differential Speed Sensor IC with Zero-Crossing Output Signal

Features

- Integrated filter capacitor
- Accurate true zero-crossing switch-point
- South and North pole pre-induction possible
- Large air gap
- 3.8 to 24V supply operating range
- Wide operating temperature range
- Protection against over-voltage in all PIN
- Reverse-current protection in VDD PIN
- Output protection against electrical disturbances

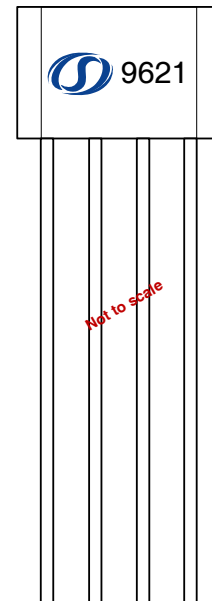

Description

The differential Hall Effect sensor SC9621 provides a high sensitivity and a superior stability over temperature and symmetrical thresholds in order to achieve a stable duty cycle. The integrated circuit is response to changing differential magnetic fields created by rotating ring magnets and by ferrous targets when coupled with a magnet. The device is particularly suitable for rotational speed detection and timing applications of ferromagnetic toothed wheels, such as, anti-lock braking systems, transmissions, crankshafts, etc.

The device is packaged in a 4-pin plastic SIP. It is lead (Pb) free, with 100% matte tin plated leadframe.



Device Information

Part Number	Packing	Mounting	Ambient, T_A	Marking
SC9621VB	Bulk, 500 pieces/bag	4-pin SIP	-40°C to 150°C	9621

Terminal Configuration and Functions

4-Terminal SIP
VB Package
(Top View)

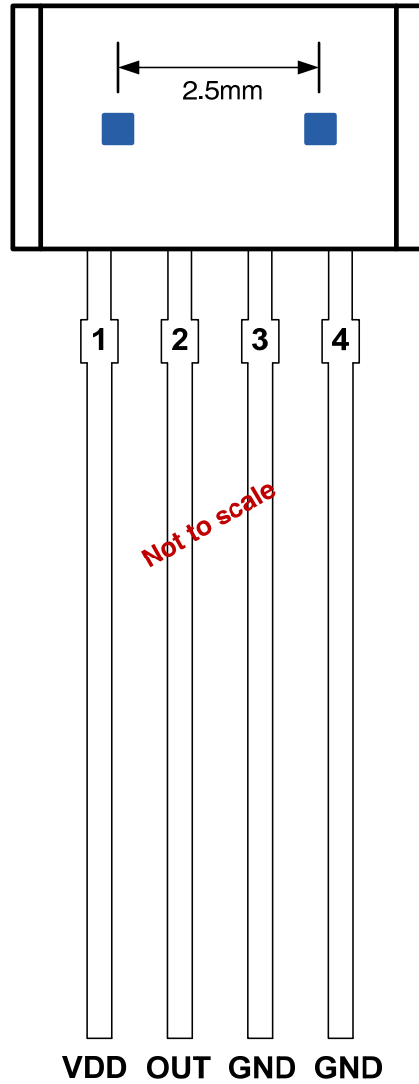

Terminal		Type	Description
Name	Number		
VDD	1	PWR	3.8 to 24 V power supply
OUT	2	Output	Open-drain output required a pull-up resistor
GND	3	Ground	Ground terminal
GND	4	Ground	Ground terminal

Functional Block Diagram

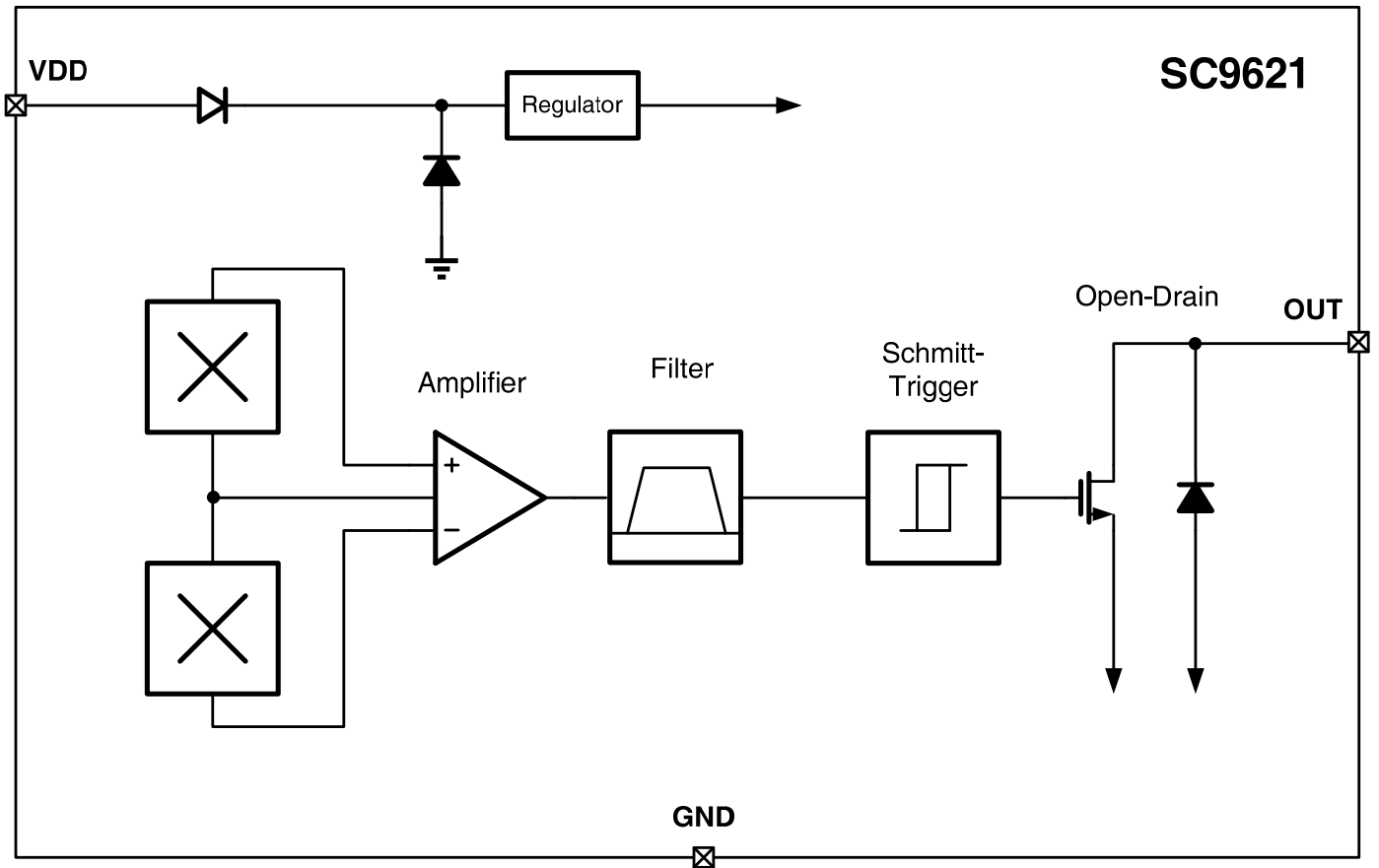

Functional Description

The SC9621 sensor IC contains two integrated Hall transducers that are used to differentially respond to a magnetic field across the surface of the IC. The trigger switches the output off (output high) when the differential magnetic field crosses zero while increasing in strength (referred to positive direction), and switches the output on (output low) when the differential magnetic field crosses zero while decreasing (the negative direction).

The operation is achieved through the use of two separate comparators. Both comparators use the same reference point, 0 G, to provide high accuracy, but one comparator has a positive hysteresis, B_{HYS1} , and the other a negative hysteresis, B_{HYS2} . Therefore, one comparator switches (B_{OP}) at the zero crossing on an increasing differential signal and the other switches (B_{RP}) at the zero crossing on a decreasing differential signal. The hysteresis on each comparator precludes false switching on noise or target jitter.

The SC9621 can be exploited to detect toothed wheel rotation in a rough environment. Jolts against the toothed wheel and ripple have no influence on the output signal. Furthermore, the device can be operated in a two-wire as well as in a three wire-configuration.

Absolute Maximum Ratings

Parameter	Symbol	Limit Values		Units
		Min.	Max.	
Power supply voltage	V _{DD}	-30	30	V
Power supply current	I _{DD}	-10	25	mA
Output terminal voltage	V _{OUT}	-0.5	30	V
Output terminal current sink	I _{SINK}	0	40	mA
Operating ambient temperature	T _A	-40	150	°C
Maximum junction temperature	T _J	-55	165	°C
Storage temperature	T _{STG}	-65	175	°C

Note: Stresses above those listed here may cause permanent damage to the device. Exposure to absolute maximum rating conditions for extended periods may affect device reliability.

ESD Protection

Human Body Model (HBM) tests according to: AEC-Q100-002

Parameter	Symbol	Limit Values		Units
		Min.	Max.	
ESD-Protection	V _{ESD}	-4	4	KV

Operating Characteristics

over operating free-air temperature range ($V_{DD}=12V$, unless otherwise noted)

Symbol	Parameter	Test Conditions	Min.	Typ.	Max.	Units
V_{DD}	Operating voltage	$T_J < T_{J(max)}$	3.8	--	24	V
I_{DD}	Operating supply current	$V_{DD}=3.5$ to 24 V	2.5	3.5	4.5	mA
V_{Qsat}	Output saturation voltage	$I_Q=20mA$, $T_A=25^\circ C$	--	150	400	mV
I_{QL}	Output leakage current	$V_{DD} < 24V$	--	--	10	μA
V_{DZ}	Overvoltage protection at VDD terminal	$I_{DD} = 10mA$	30	35	40	V
V_{OZ}	Overvoltage protection at OUT terminal	$V_Q = High$ $I_Q = 1mA$	30	35	40	V
OCP ¹	Over current protection	$T_A=25^\circ C$	40	--	--	mA
t_{po} ²	Power-on time	$V_{DD}>3.5V$	--	3.8	9	mS
t_{settle} ³	Settling time	$V_{DD}>3.5V$, $f=1kHz$	0	--	50	mS
$t_{response}$ ⁴	Response time	$V_{DD}>3.5V$, $f=1kHz$	3.8	--	59	mS
t_r ⁵	Output rise time	$R1=1Kohm$ $C_Q=20pF$	--	--	0.2	μS
t_f	Output fall time	$R1=1Kohm$ $C_Q=20pF$	--	--	0.2	μS
f_{cu}	Upper corner frequency	-3dB, single pole	20	--	--	kHz
f_{cl}	Lower corner frequency	-3dB, single pole	--	--	5	Hz
Magnetic Characteristics						
B_{Back}	Pre-induction		-500	--	500	mT
B_{Diff} ⁶	Differential fields	$f=1kHz$	-100	--	100	mT
B_{HYS}	Postive and negtive hysteresis	$f=1kHz$, $B_{Diff}=5mT$	0.4	1.2	2.0	mT

¹ I_{OUT} does not change state when $I_{OUT}=OCP$.

²Time required to initialize device.

³Time required for the output switch points to be within specification.

⁴ Equal to $t_{po} + t_{settle}$.

⁵Output Rise Time will be dominated by the RC time constant.

⁶Exceeding this limit might result in decreased duty cycle performance and the phase accuracy.

Thermal Characteristics

Symbol	Parameter	Test Conditions	Rating	Units
$R_{\theta JA}$	Package thermal resistance	Single-layer PCB, with copper limited to solder pads	177	$^{\circ}\text{C}/\text{W}$

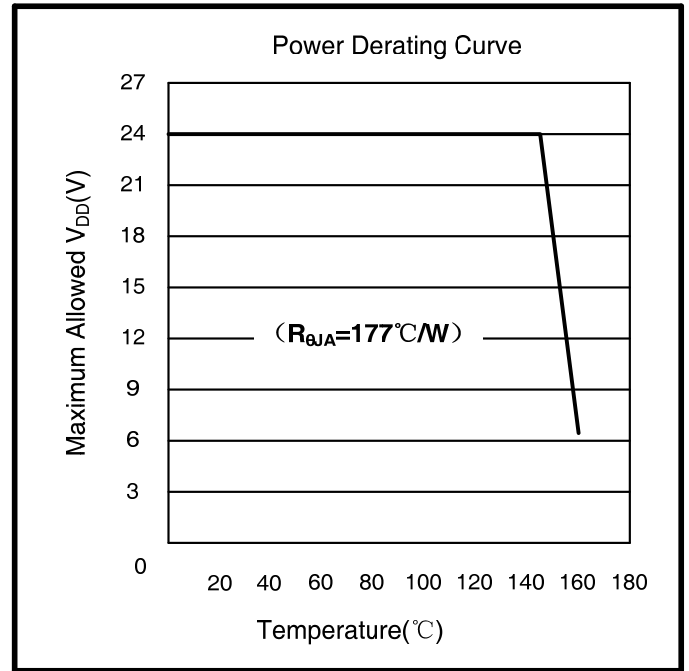
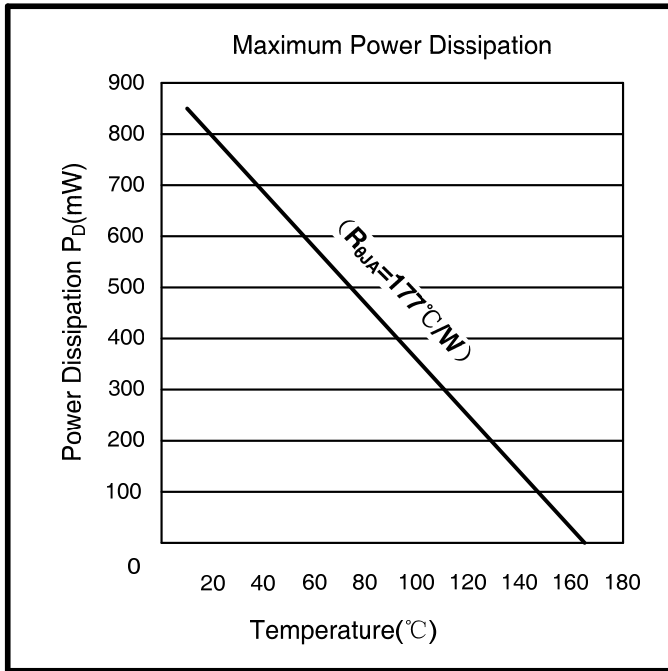

Power Derating Description

The device must be operated below the maximum junction temperature of the device, $T_{J(max)}$. Under certain combinations of peak condition, reliable operation may require derating supplied power or improving the heat dissipation properties of the application.

The package Thermal Resistance, $R_{\theta JA}$, is figure of merit summarizing the ability of the application and device to dissipate heat from the junction, through all paths to the ambient air. Its primary component is an Effective Thermal Conductivity, K, of the printed circuit board, including adjacent devices and traces. Radiation from the die through the device case, $R_{\theta JC}$, is relatively small component of $R_{\theta JA}$. Ambient air temperature, T_A , and air motion are significant external factors, damped by over molding.

The effect of varying power levels (Power Dissipation, P_D), can be estimated. The following formulas represent the fundamental relationships used to estimate T_J , at P_D .

$$P_D = V_{DD} \times I_{DD} \quad (1)$$

$$\Delta T = P_D \times R_{\theta JA} \quad (2)$$

$$T_J = T_A + \Delta T \quad (3)$$

For example $T_A = 25^\circ\text{C}$, $V_{DD} = 12\text{V}$, $I_{DD} = 3.5\text{mA}$, $R_{\theta JA} = 177^\circ\text{C/W}$.

$$P_D = V_{DD} \times I_{DD} = 12\text{V} \times 3.5\text{mA} = 42\text{mW}$$

$$\Delta T = P_D \times R_{\theta JA} = 42\text{mW} \times 177^\circ\text{C/W} = 7.5^\circ\text{C}$$

$$T_J = T_A + \Delta T = 25^\circ\text{C} + 7.5^\circ\text{C} = 32.5^\circ\text{C}$$

Empirical Result

I_{DD} vs V_{DD}

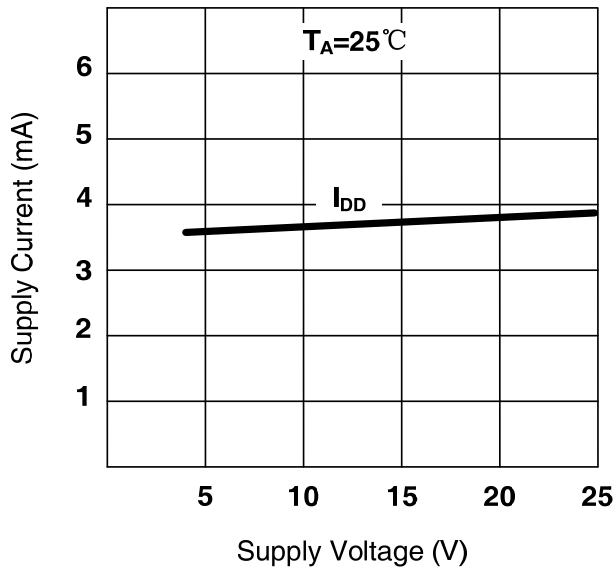

I_{DD} vs T_A

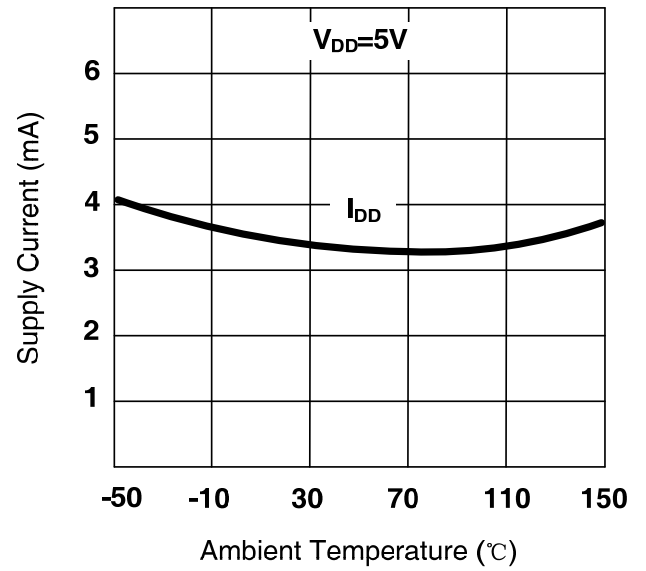

$V_{Q(sat)}$ vs V_{DD}

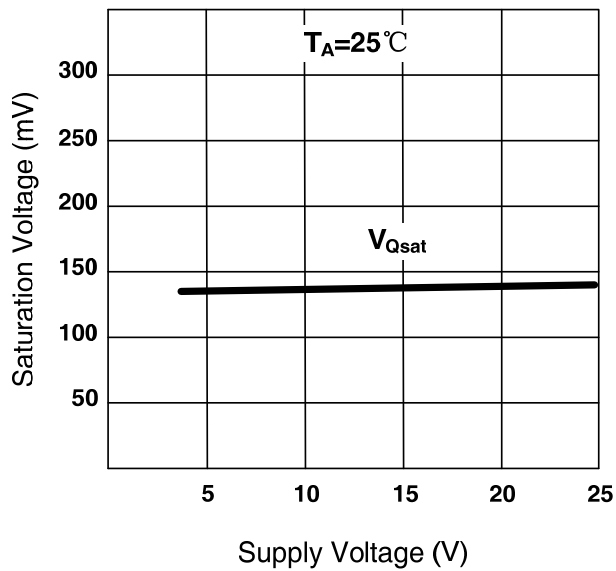

$V_{Q(sat)}$ vs T_A

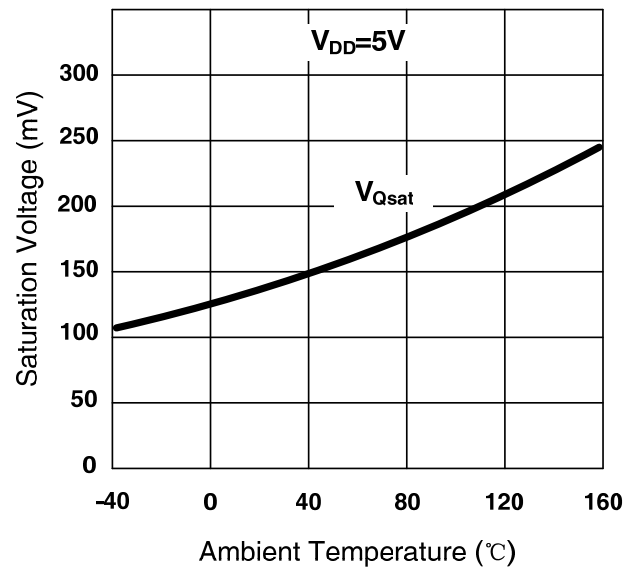

Empirical Result (continued)

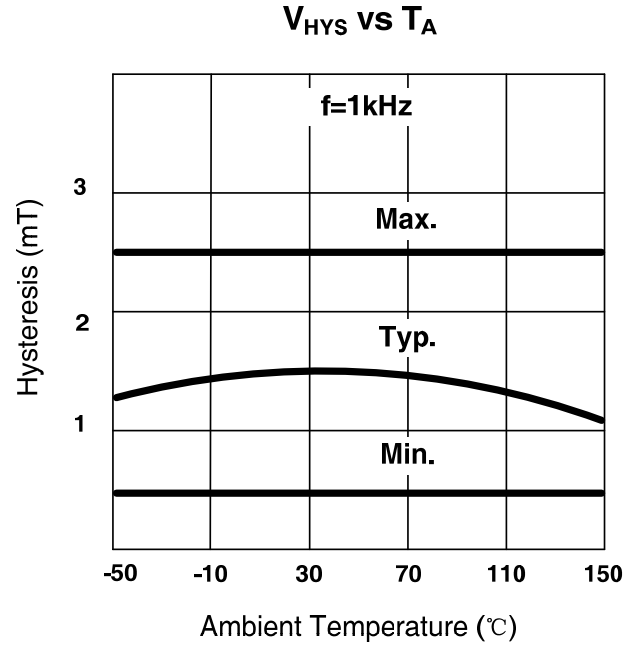
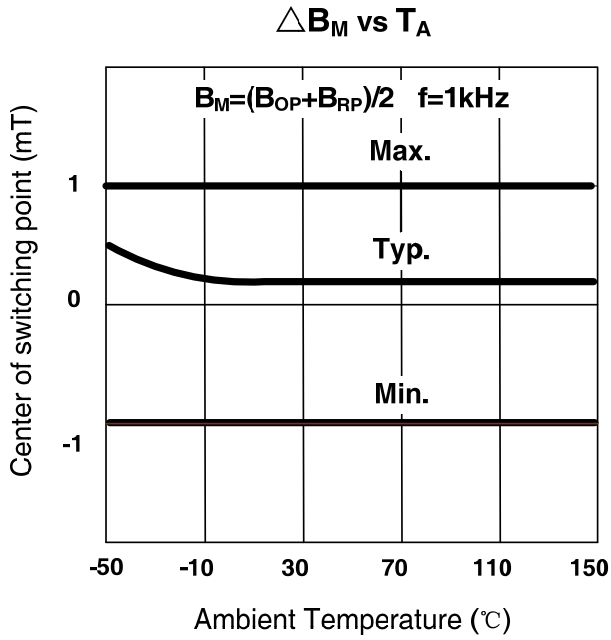

Simulation Result

Minimum Switch Fields versus Frequency

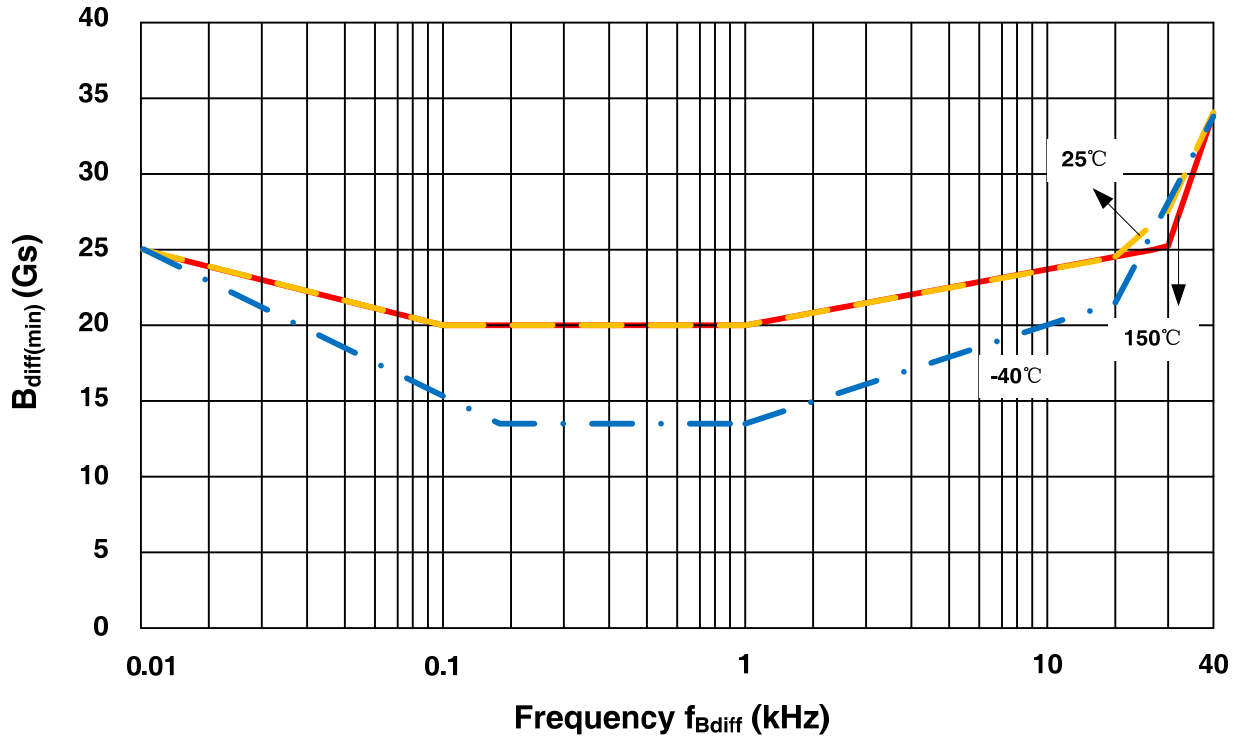

Typical Phase Shift versus Frequency

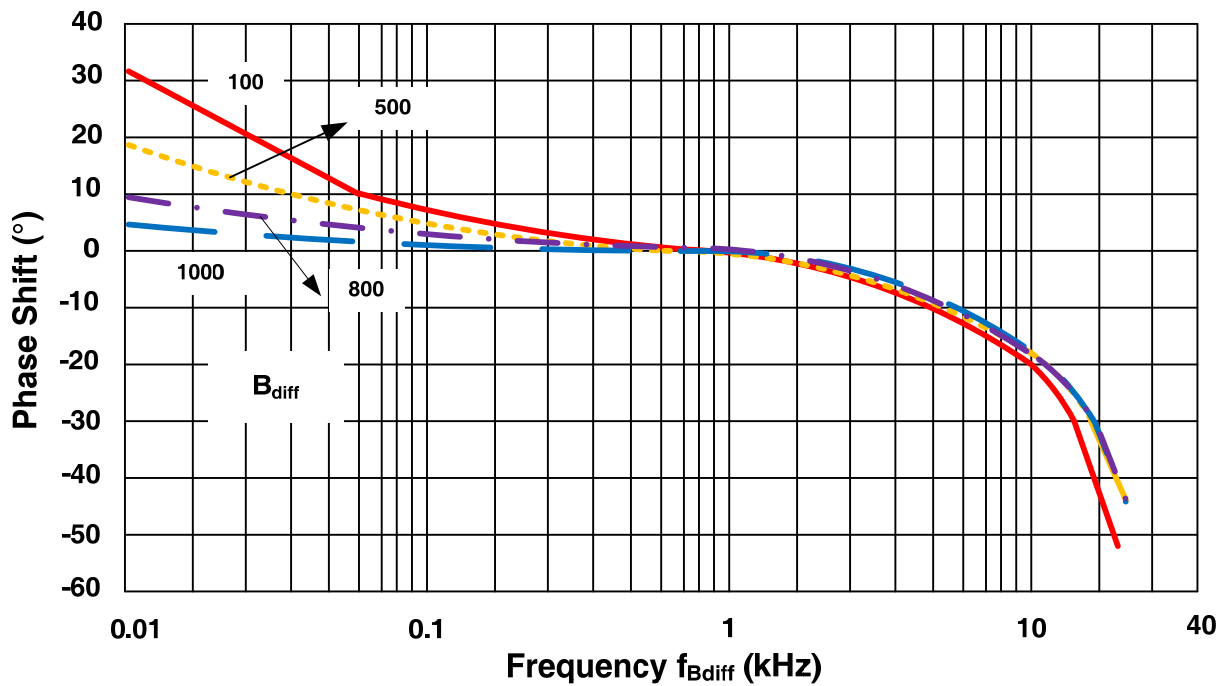

Gear Tooth Sensing

In the case of ferromagnetic toothed wheel application the IC has to be biased by the South or North pole of a permanent magnet which should cover both Hall probes

The maximum air gap depends on

- the magnetic field strength (magnet used; pre-induction), and
- the toothed wheel that is used (dimensions, material, etc.)

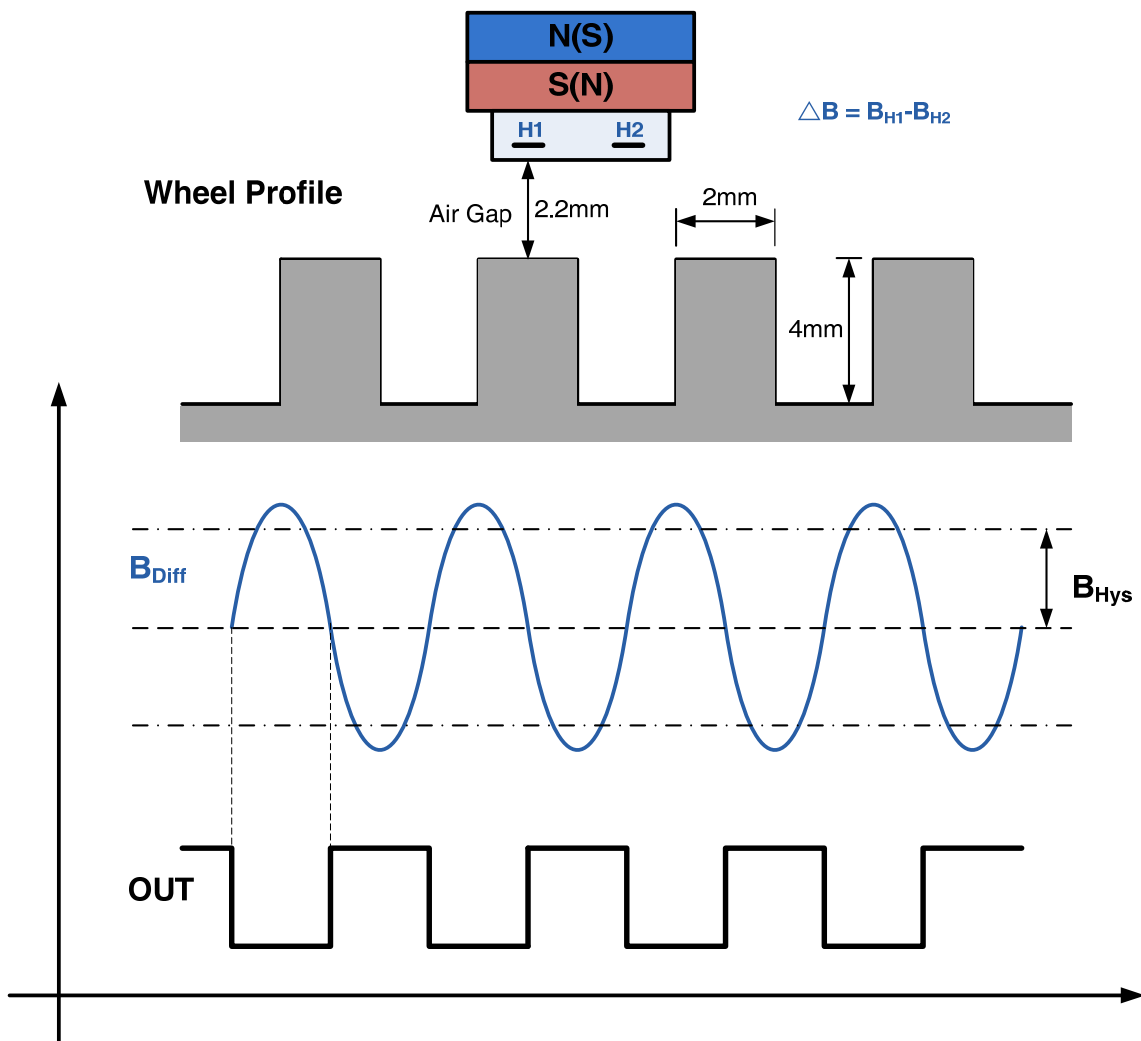

Recommended Application

The SC9621 contains an on-chip voltage regulator and can operate over a wide supply voltage range. In applications that operate the device from an unregulated power supply, transient protection must be added externally. For applications using a regulated line, EMI/RFI protection may still be required.

Three-wire-application

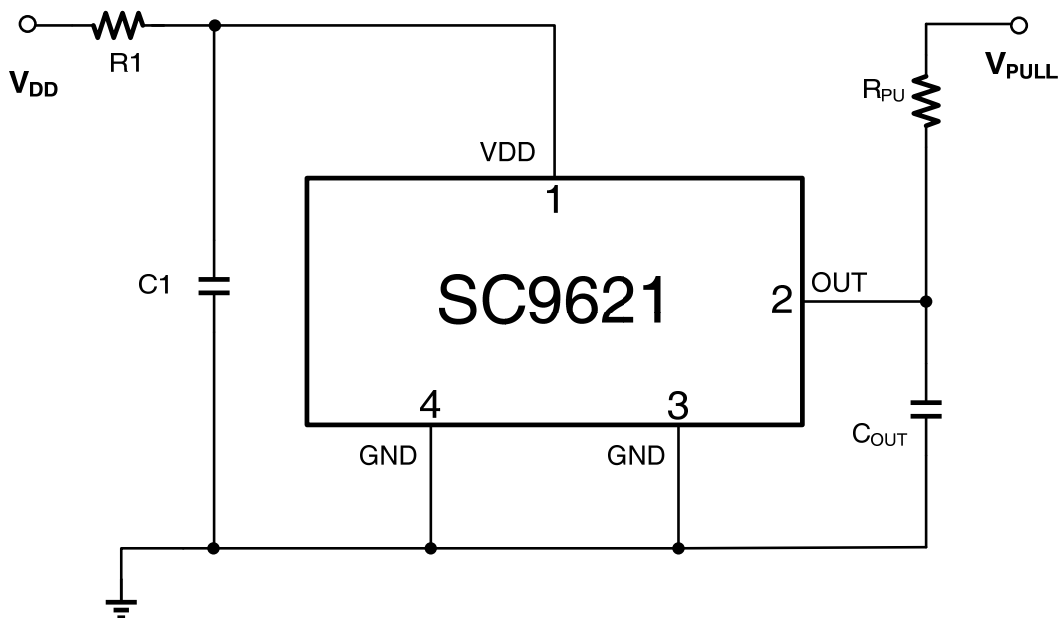

Component	Value	Units
R _{PU}	1.2	kΩ
R1	200	Ω
C1	0.1	μF
C _{OUT}	1.0	nF

1. Pull-up resistor not required for protection but for normal operation
2. R1 is for improved CI performance
3. C_{OUT} is for improved BCI performance

Package Designator

4-Terminal VB Package

Dimension:mm

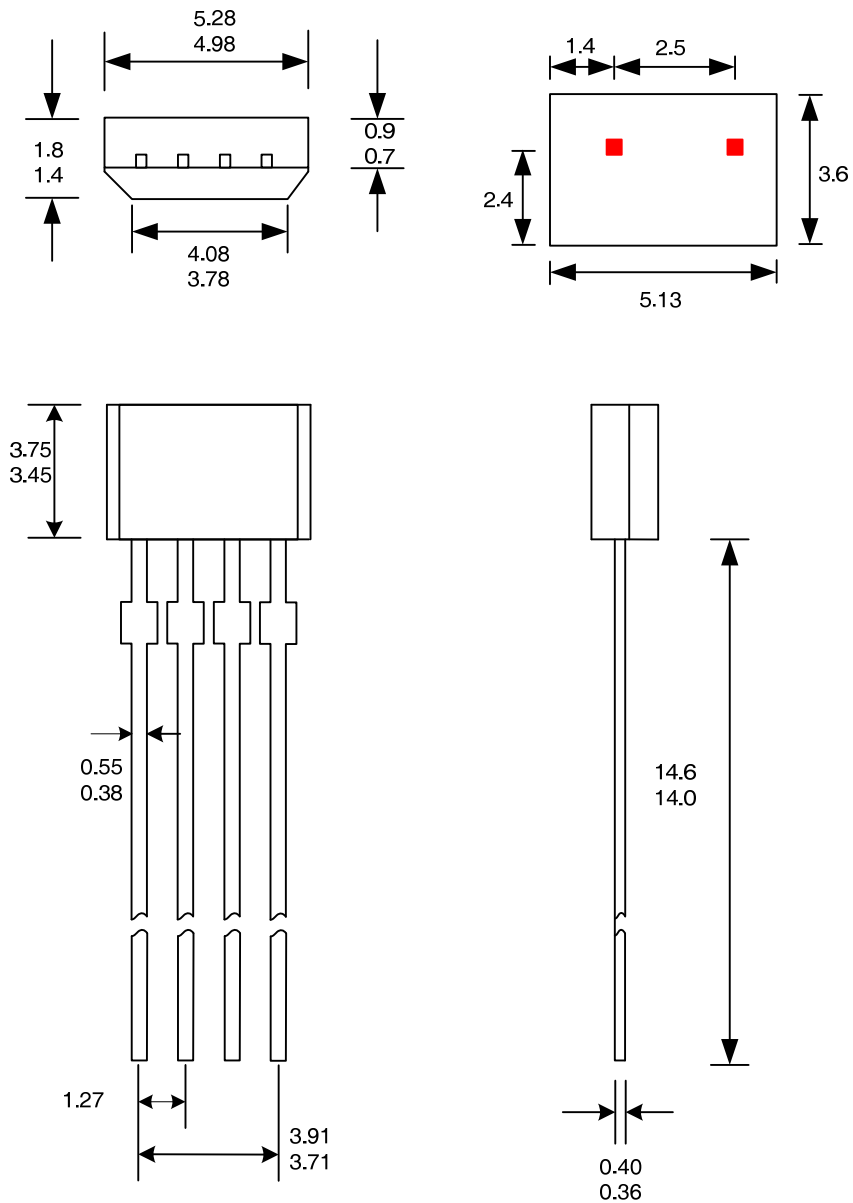

Notes:

1. Exact body and lead configuration at vendor's option within limits shown.
2. Height does not include mold gate flash.

Where no tolerance is specified, dimension is nominal.