

Product Description

The QPD3601 is a discrete GaN on SiC HEMT which operates from 3.4–3.6 GHz. The device is a single stage matched power amplifier transistor.

The QPD3601 can be used in Doherty architecture for the final stage of a base station power amplifier for macrocell high efficiency systems.

QPD3601 can deliver P_{SAT} of 206 W at +50 V operation.

ROHS compliant.

Functional Block Diagram

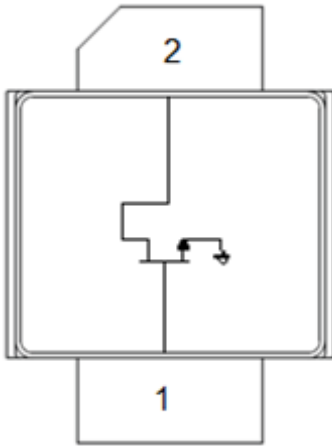

2 Lead NI400 Package

Product Features

- Operating Frequency Range: 3.4 – 3.6 GHz
- Operating Drain Voltage: +50 V
- Output Power (P_{SAT}): 206 W
- Drain Efficiency: 57.9%
- Efficiency-Tuned P3dB Gain: 16.3 dB
- 2-lead, earless, ceramic flange NI400 package

Applications

- W-CDMA / LTE
- Macrocell Base Station
- Active Antenna

Ordering Information

Part No.	ECCN	Description
QPD3601	3A001.b.3.a.3	200 W, 3.4 – 3.6 GHz, GaN Discrete
QPD3601-EVB	EAR99	3.4-3.6 GHz Eval. Board



Absolute Maximum Ratings

Parameter	Value / Range
Gate Voltage (V_G)	-10 V
Drain Voltage (V_D)	+55 V
Maximum RF Input Power	42 dBm
VSWR Mismatch, P1dB Pulse (20 % duty cycle, 100 μ width), T = 25 °C	10:1
Storage Temperature	-65 to +150°C

Operation of this device outside the parameter ranges given above may cause permanent damage.

Recommended Operating Conditions

Parameter	Min	Typ	Max	Units
Operating Temperature	-40	-	-	°C
Gate Current (I_G)	-	-	15	mA
Gate Voltage (V_G)	-3.3	-2.7	-2.5	V
Drain Voltage (V_D)	-	50	-	V
Quiescent Current (I_{DQ})	-	360	-	mA
T_{CH} for >10 ⁶ hours MTTF	-	-	250	°C

Electrical performance is measured under conditions noted in the electrical specifications table. Specifications are not guaranteed over all recommended operating conditions.

Electrical Specifications

Parameter	Conditions	Min	Typ	Max	Units
Frequency Range		3400	-	3600	MHz
Quiescent Current		-	360	-	mA
Gain	P3dB	15.0	16.3	-	dB
P3dB		52.5	53.1	-	dBm
Drain Efficiency	P3dB	51.0	57.9	-	%
Gate Leakage	$V_D = +50$ V, $V_G = -5$ V	-10.0	-3.5	-	mA

Test conditions unless otherwise noted: $V_D = +50$ V, $I_{DQ} = 360$ mA, T = 25°C, Pulsed (10 % duty cycle, 100 μ s width), on Class AB single-ended EVB at 3500 MHz

Thermal and Reliability Information

Parameter	Test Conditions	Value	Units
Thermal Resistance at Average Power (θ_{JC})	$T_{CASE} = 85^{\circ}C$, $T_{CH} = 157^{\circ}C$ CW: $P_{DISS} = 51 W$, $P_{OUT} = 45 W$	1.42	$^{\circ}C/W$

Notes:

1. Thermal resistance measured to package backside.
2. Based on expected carrier amplifier efficiency of Doherty.
3. Pout assumes 20% peaking amplifier contribution of total average Doherty rated power.

Median Lifetime

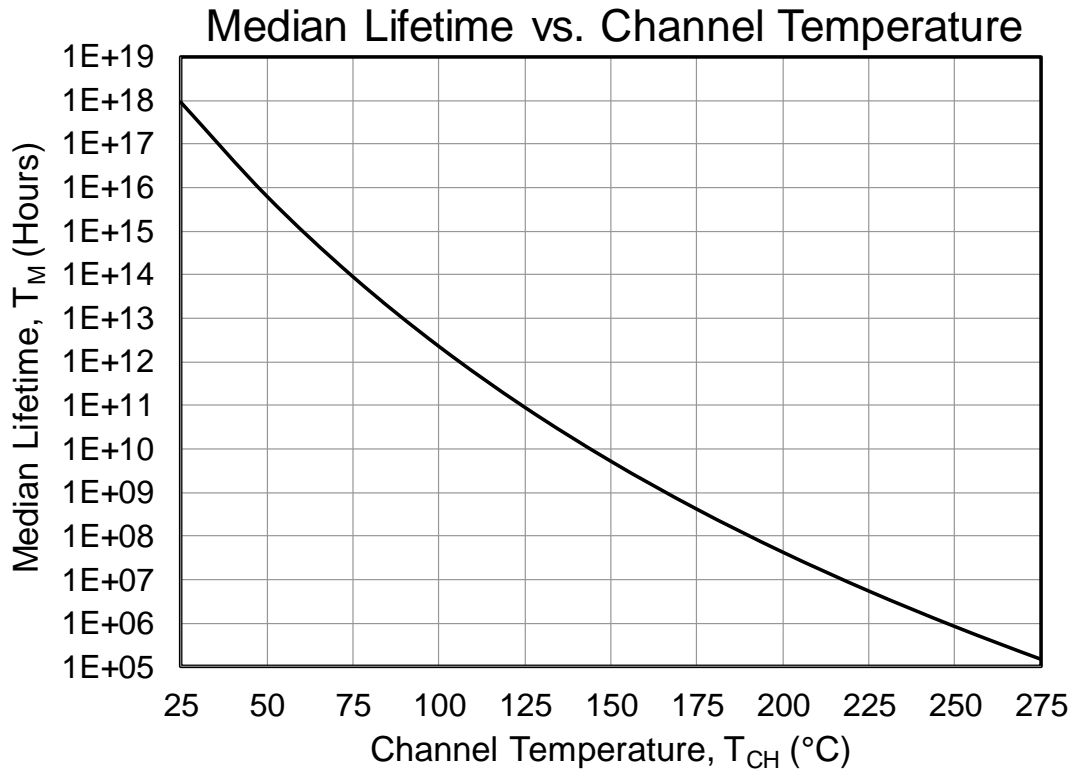

Single-Ended Evaluation Board Layout

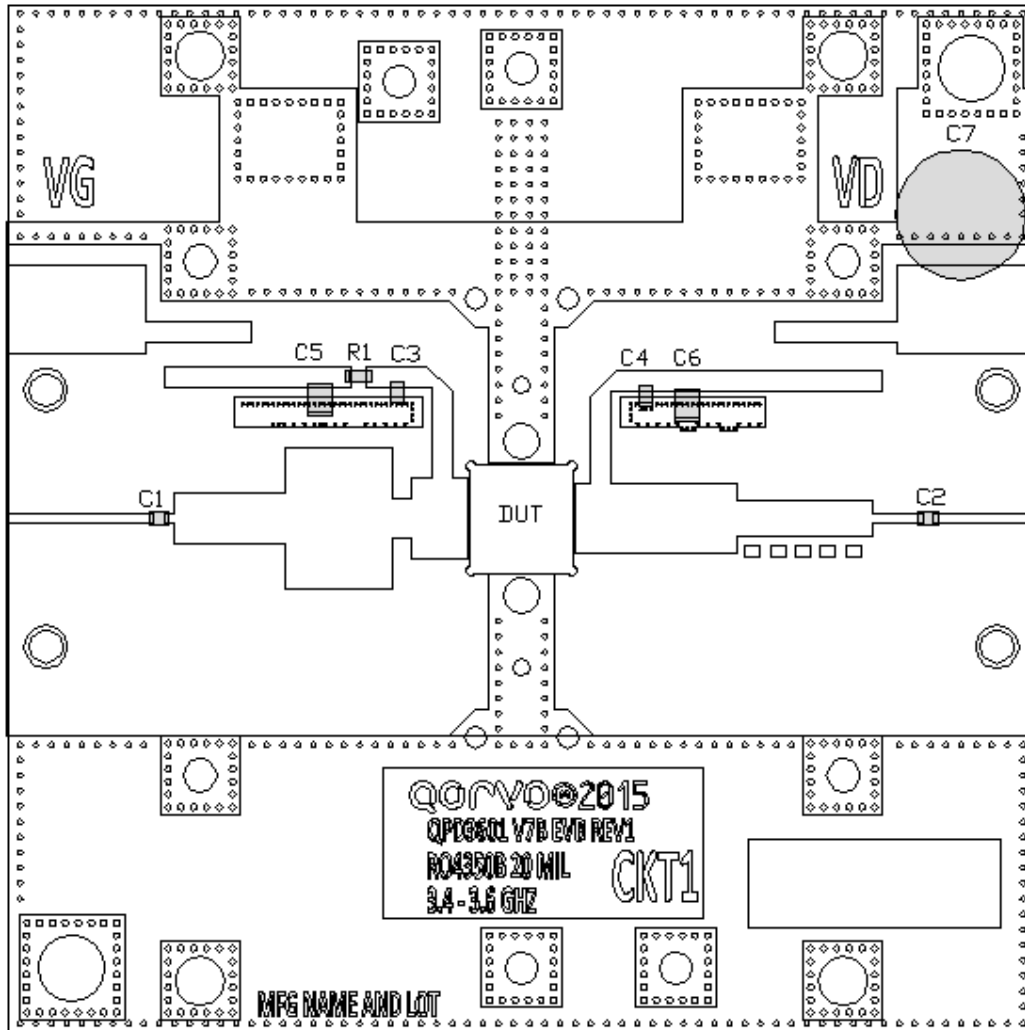

Bill of Materials

Reference	Value	Description	Manuf.	Part Number
C1, C2, C3, C4	8.2 pF	Capacitor, 8.2 pF	ATC	600F8R2BW250T
C5	10 μF	Capacitor, 10 μF, 50 V	TDK	C5750X7R1H106K230KB
C6	10 μF	Capacitor, 10 μF, 100 V	TDK	C5750X7S2A106M230KB
C7	220 μF	Capacitor, 220 μF, electrolytic, 100 V	Cornell D.	AFK227M2AR44T-F
R1	10 Ω	Resistor, 10 Ω, 1/8 W	Vishay/Dale	CRCW060310R0FKEA

Single-Ended Evaluation Board Performance Plots

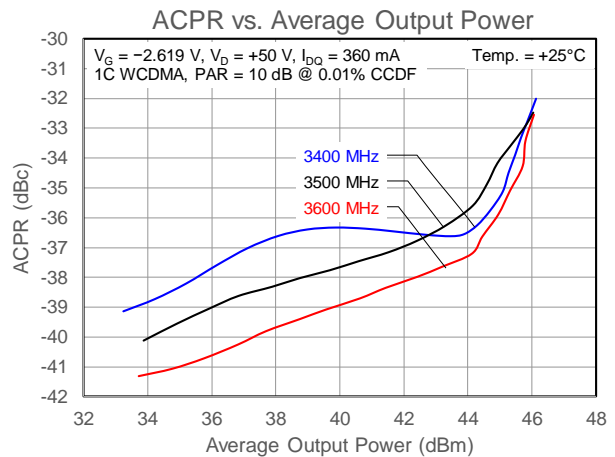
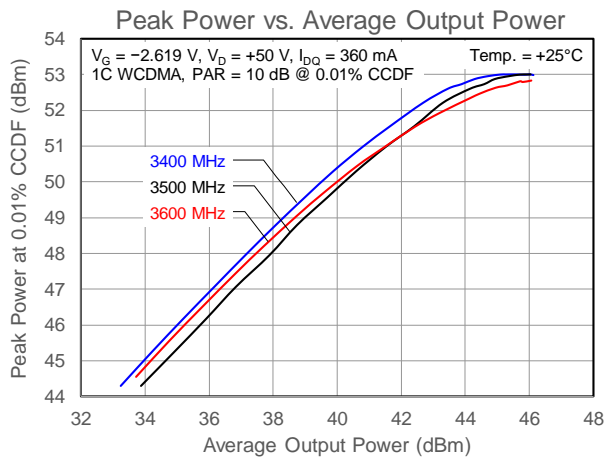
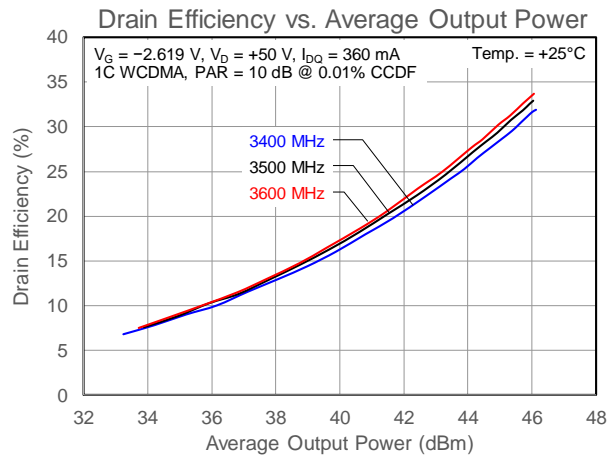
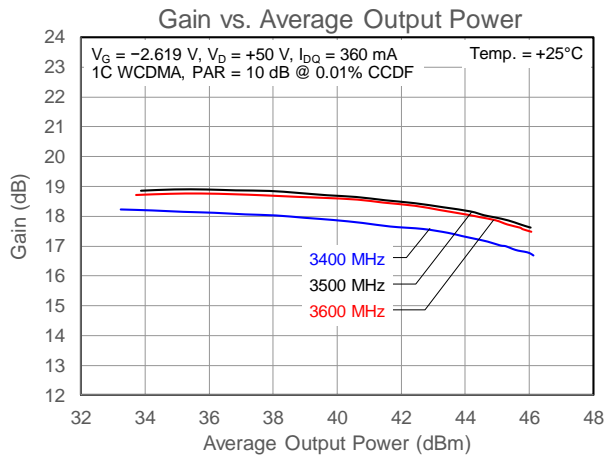
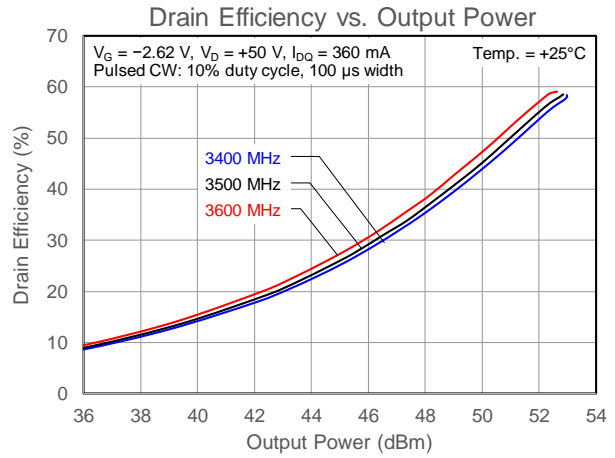
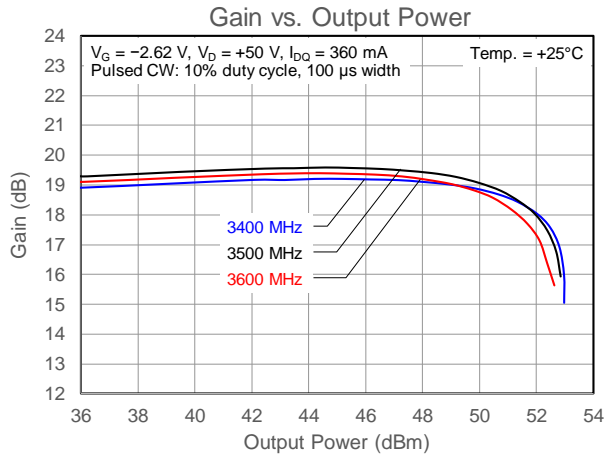

Test conditions unless otherwise noted: $V_D = +50 \text{ V}$, $I_{DQ} = 360 \text{ mA}$, $T = 25^\circ\text{C}$, on Class AB single-ended EVB at 3500 MHz

Single-Ended Evaluation Board Performance Plots

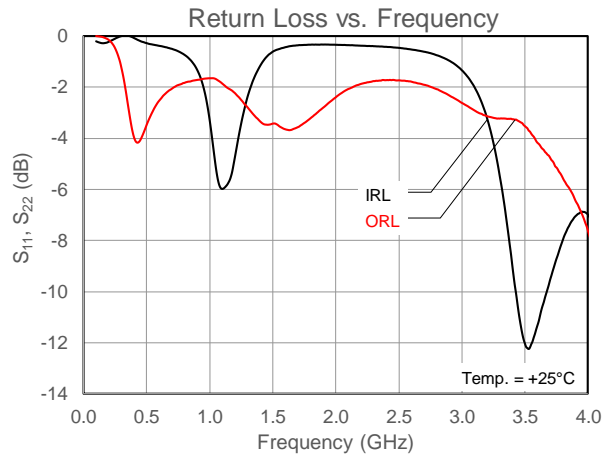
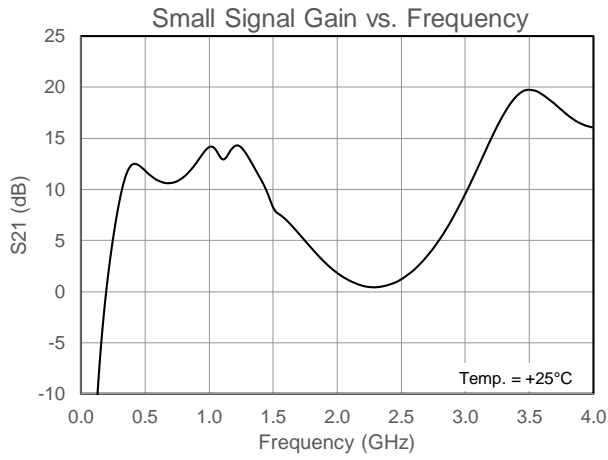

Test conditions unless otherwise noted: $V_D = +50\text{ V}$, $I_{DQ} = 360\text{ mA}$, $T = 25^\circ\text{C}$, on Class AB single-ended EVB at 3500 MHz

RF Characterization – Power-Tuned Load Pull Performance

Frequency (MHz)	Source Impedance	Load Impedance	Gain @ P3dB (dB)	P3dB (dBm)	Drain Efficiency (%)
3400	11.50 – j*15.57	7.76 – j*0.96	16.2	53.2	53.3
3500	18.05 – j*10.41	6.01 – j*0.73	16.6	53.3	55.4
3600	13.17 – j*1.70	6.01 – j*0.73	16.7	53.4	60.4

Test conditions unless otherwise noted: $V_D = +50$ V, $I_{DQ} = 360$ mA, $T = 25^\circ\text{C}$, Pulsed 10% duty cycle, 100 μs width)

RF Characterization – Efficiency-Tuned Carrier Load Pull Performance

Frequency (MHz)	Source Impedance	Load Impedance	Gain @ P3dB (dB)	P3dB (dBm)	Drain Efficiency (%)
3400	11.50 – j*15.57	5.38 – j*9.66	19.0	50.7	65.9
3500	18.05 – j*10.41	6.47 – j*6.83	19.2	51.7	67.2
3600	13.17 + j*1.70	8.05 – j*5.51	18.7	52.0	69.9

Test conditions unless otherwise noted: $V_D = +50$ V, $I_{DQ} = 360$ mA, $T = 25^\circ\text{C}$, Pulsed 10% duty cycle, 100 μs width)

Load Pull Plots

Load Pull at 3.4 GHz

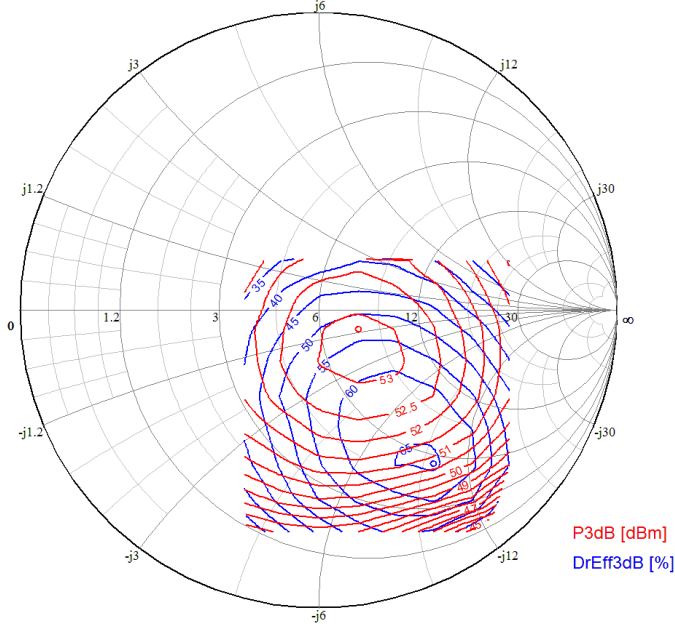

Load Pull at 3.5 GHz

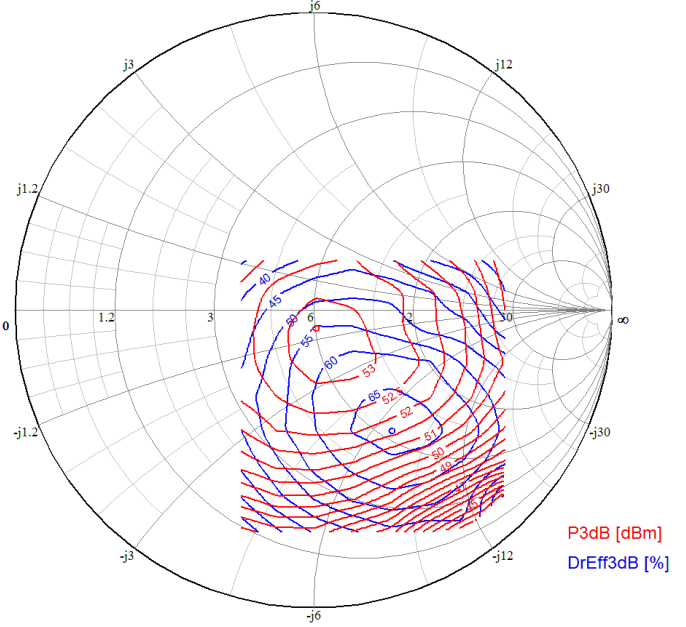

Load Pull at 3.6 GHz

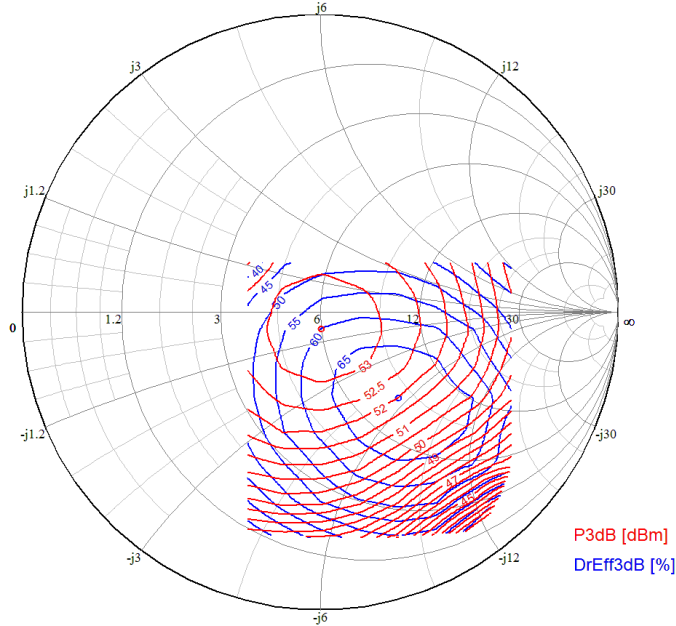

Test conditions unless otherwise noted: $V_D = +50$ V, $I_{DQ} = 360$ mA, $T = 25^\circ\text{C}$, Pulsed 10% duty cycle, 100 μs width)

Pin Configuration

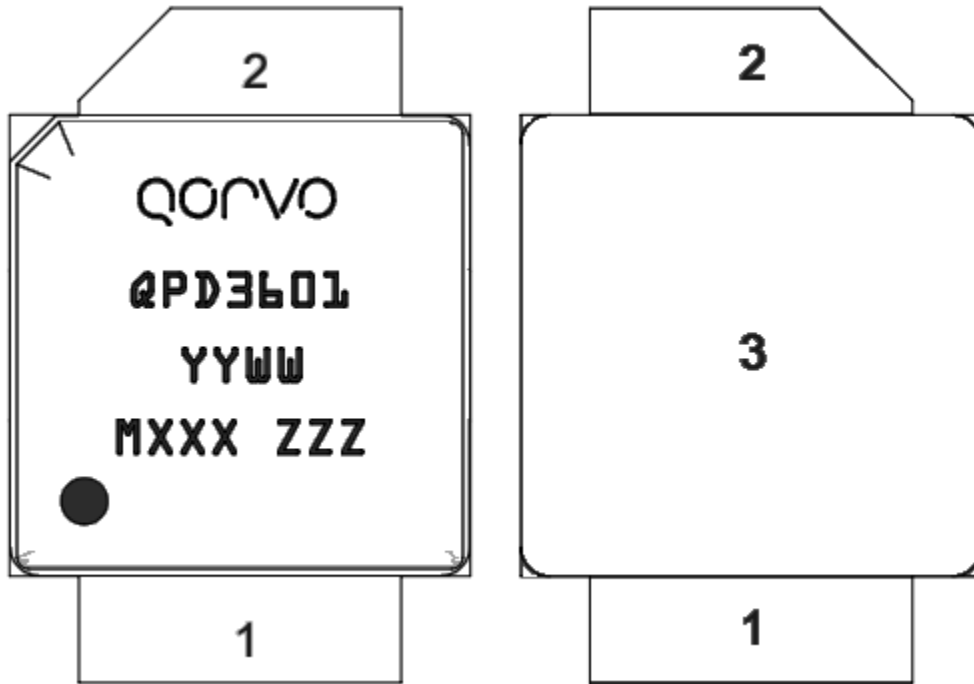

Pin Description

Pin No.	Label	Description
1	RF IN, V_G	RF Input, Gate Bias
2	RF OUT, V_D	RF Output, Drain Bias
3 (Backside Paddle)	RF/DC GND	RF/DC Ground

Package Marking and Dimensions

Marking: Qorvo Logo
 Part Number and Package Version – QPD3601
 Date Code – YYWW
 Production Lot Number – MXXX
 Serial Number – ZZZ

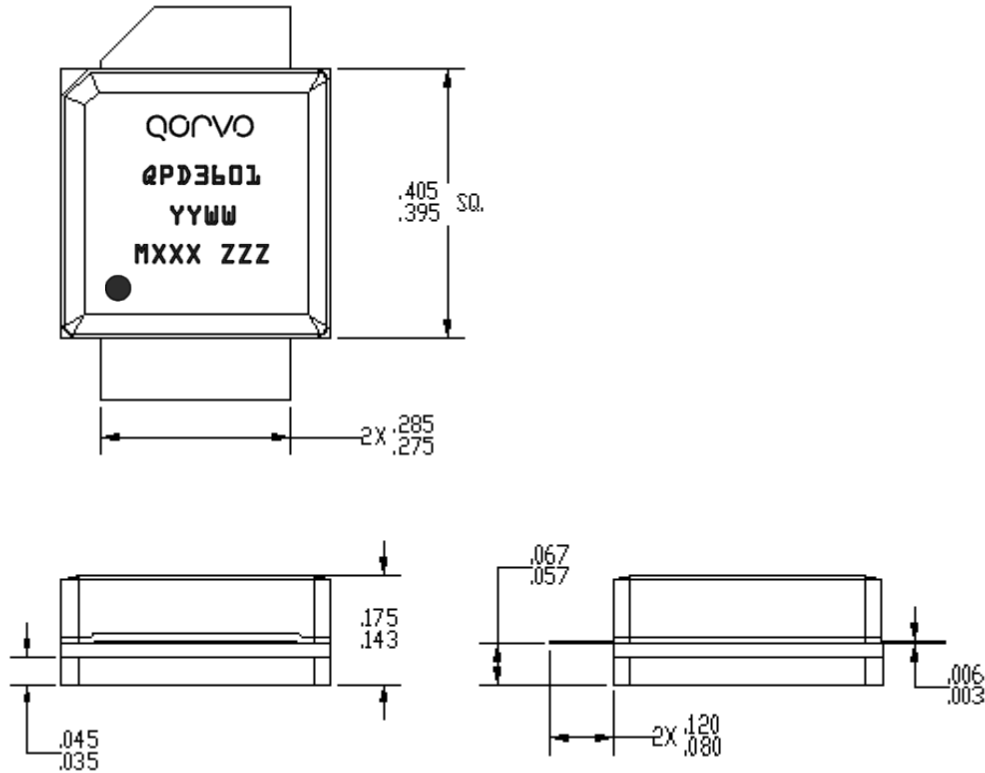

Notes:

1. All dimensions are in inches. Angles are in degrees.
2. Exposed metallization is NiAu plated.

Tape and Reel Information – Carrier and Cover Tape Dimensions

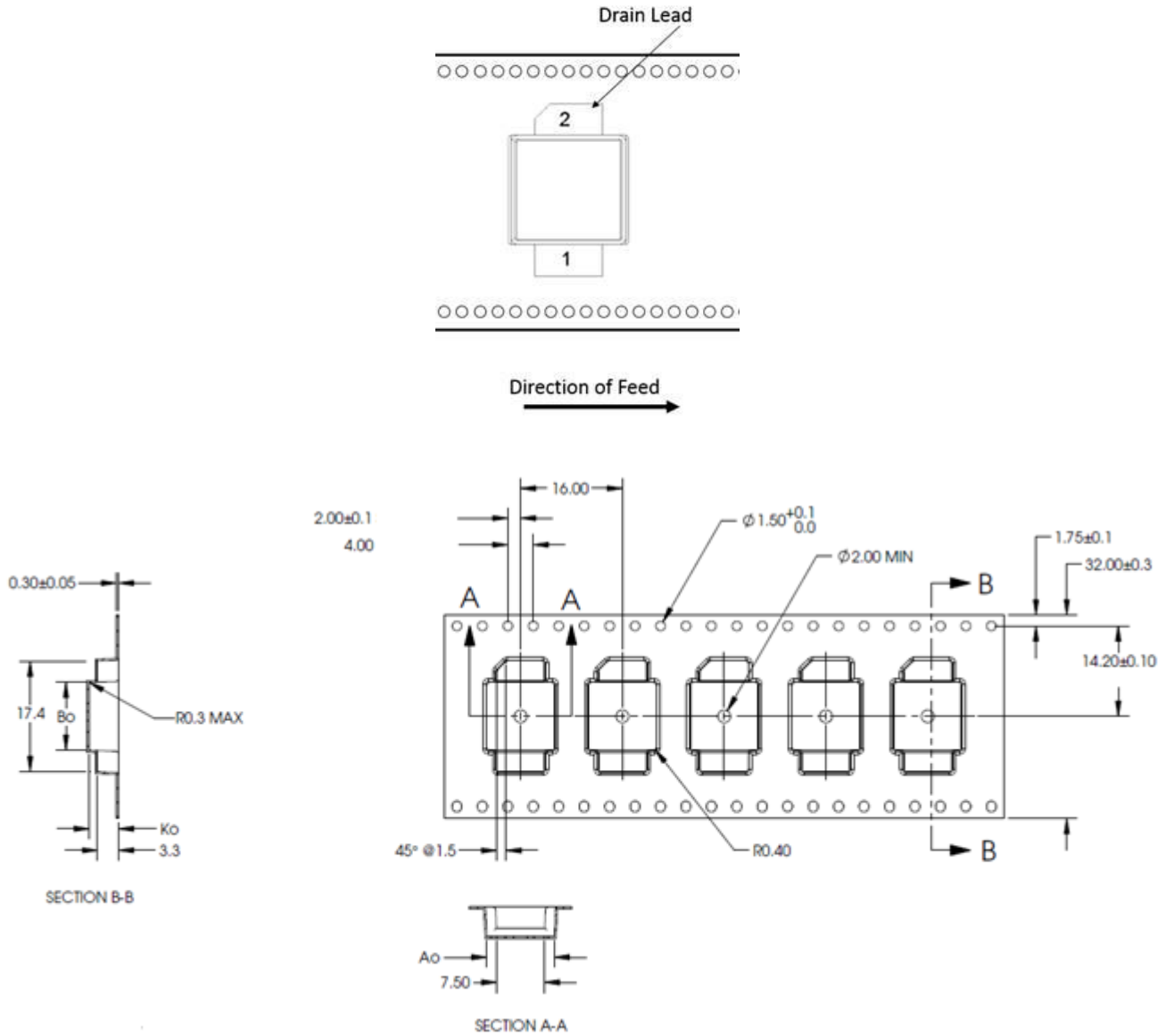

Feature	Measure	Symbol	Size (in)	Size (mm)
Cavity	Length	A0	0.417	10.60
	Width	B0	0.419	10.65
	Depth	K0	0.181	4.60
	Pitch	P1	0.630	16
Centerline Distance	Cavity to Perforation – Length Direction	P2	0.079	2.00
	Cavity to Perforation – Width Direction	F	0.559	14.20
Cover Tape	Width	C	1.004	25.50
Carrier Tape	Width	W	1.260	32

Tape and Reel Information – Reel Dimensions

Standard T/R size = 250 pieces on a 13" reel.

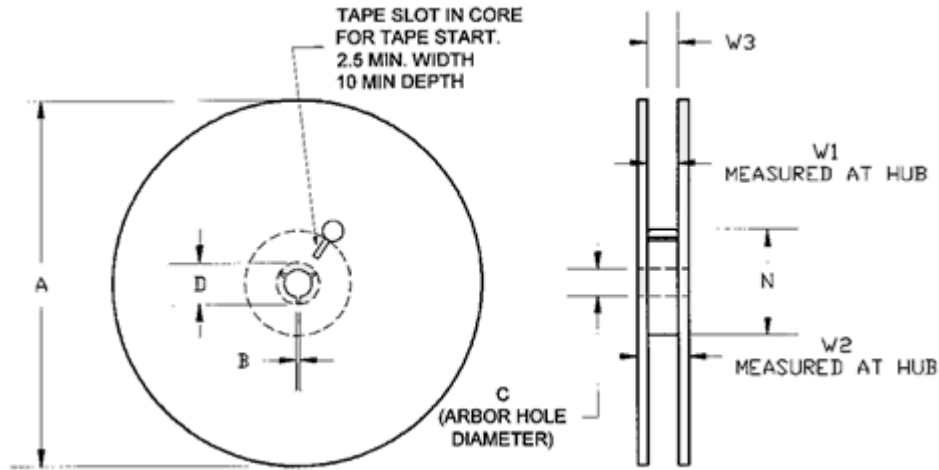

Feature	Measure	Symbol	Size (in)	Size (mm)
Flange	Diameter	A	12.992	330.0
	Thickness	W2	1.504	38.2
	Space Between Flange	W1	1.291	32.8
Hub	Outer Diameter	N	4.016	102.0
	Arbor Hole Diameter	C	0.512	13.0
	Key Slit Width	B	0.079	2.0
	Key Slit Diameter	D	0.787	20.0

Tape and Reel Information – Tape Length and Label Placement

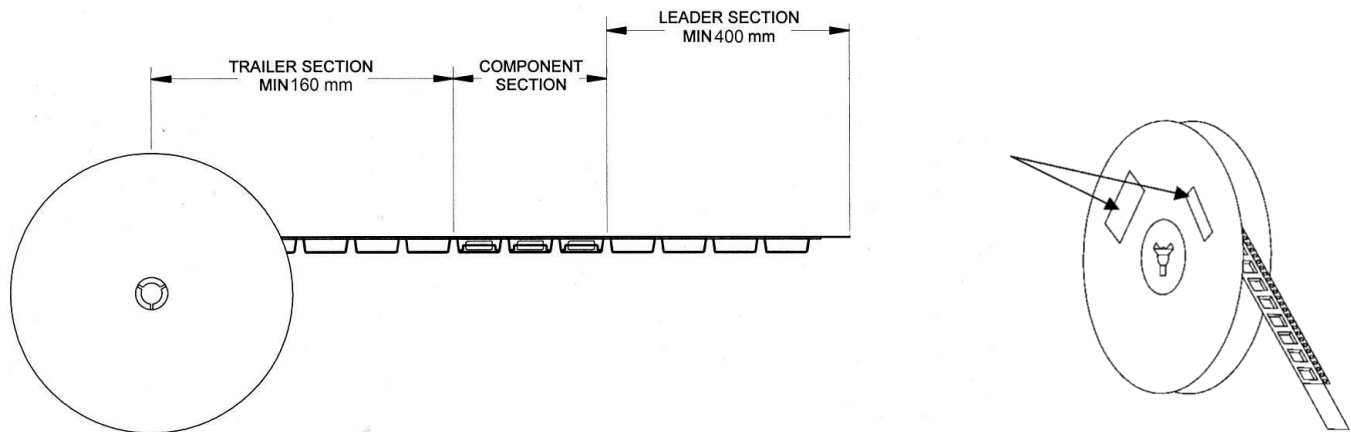

Notes:

1. Empty part cavities at the trailing and leading ends are sealed with cover tape. See EIA 481-1-A.
2. Labels are placed on the flange opposite the sprockets in the carrier tape.