

## Applications

- Military radar
- Civilian radar
- Professional and military radio communications
- Test instrumentation
- Wideband or narrowband amplifiers
- Jammers



## Product Features

- Frequency: DC to 6 GHz
- Output Power ( $P_{3dB}$ ): 19 W at 5.2 GHz
- Linear Gain: >9 dB at 5.2 GHz
- Operating Voltage: 28 V
- Low thermal resistance package

## Functional Block Diagram

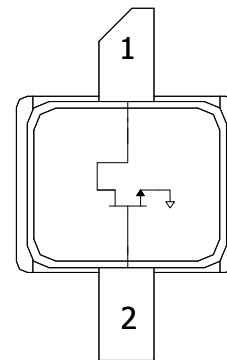

## General Description

The TriQuint T2G6001528-Q3 is an 18W ( $P_{3dB}$ ) discrete GaN on SiC HEMT which operates from DC to 6.0 GHz. The device is constructed with TriQuint's proven TQGaN25 process, which features advanced field plate techniques to optimize power and efficiency at high drain bias operating conditions. This optimization can potentially lower system costs in terms of fewer amplifier line-ups and lower thermal management costs.

Lead-free and ROHS compliant

Evaluation boards are available upon request.

## Pin Configuration

Pin No.	Label
1	$V_D$ / RF OUT
2	$V_G$ / RF IN
Flange	Source

## Ordering Information

Part	ECCN	Description
T2G6001528-Q3	EAR99	Packaged part Flangeless
T2G6001528-Q3-EVB1	EAR99	5.0 – 6.0 GHz Evaluation Board
T2G6001528-Q3-EVB2	EAR99	1.8 – 2.6 GHz Evaluation Board

## Absolute Maximum Ratings

Parameter	Value
Breakdown Voltage ( $V_{D0}$ )	100 V min.
Gate Voltage Range ( $V_G$ )	-7 to 0 V
Drain Current ( $I_D$ )	5 A
Gate Current ( $I_G$ )	-5 to 14 mA
Power Dissipation ( $P_D$ )	28 W
RF Input Power, CW, $T = 25^\circ\text{C}$ ( $P_{IN}$ )	36 dBm
Channel Temperature ( $T_{CH}$ )	275 $^\circ\text{C}$
Mounting Temperature (30 seconds)	320 $^\circ\text{C}$
Storage Temperature	-40 to 150 $^\circ\text{C}$

Operation of this device outside the parameter ranges given above may cause permanent damage. These are stress ratings only, and functional operation of the device at these conditions is not implied.

## Recommended Operating Conditions<sup>(1)</sup>

Parameter	Value
Drain Voltage ( $V_D$ )	32 V (Typ.)
Drain Quiescent Current ( $I_{DQ}$ )	50 mA (Typ.)
Peak Drain Current ( $I_D$ )	1.4 A (Typ.)
Gate Voltage ( $V_G$ )	-2.9 V (Typ.)
Channel Temperature ( $T_{CH}$ )	225 $^\circ\text{C}$ (Max)
Power Dissipation, CW ( $P_D$ ) <sup>2</sup>	20.9 W (Max)
Power Dissipation, Pulse ( $P_D$ ) <sup>3</sup>	22.5 W (Max)

<sup>1</sup> Electrical specifications are measured at specified test conditions.

Specifications are not guaranteed over all recommended operating conditions.

<sup>2</sup> Package at 85  $^\circ\text{C}$

<sup>3</sup> 100uS Pulse Width, 20 % Duty Cycle, package at 85  $^\circ\text{C}$

## RF Characterization – Load Pull Performance at 3.0 GHz

Test conditions unless otherwise noted:  $T_A = 25^\circ\text{C}$ ,  $V_D = 28\text{ V}$ ,  $I_{DQ} = 50\text{ mA}$ , Pulse: 100uS, 20%

Symbol	Parameter	Min	Typical	Max	Units
$G_{LIN}$	Linear Gain		16.5		dB
$P_{3dB}$	Output Power at 3 dB Gain Compression		19.6		W
$DE_{3dB}$	Drain Efficiency at 3 dB Gain Compression		69.6		%
$PAE_{3dB}$	Power-Added Efficiency at 3 dB Gain		66.4		%
$G_{3dB}$	Gain at 3 dB Compression		13.5		dB

## RF Characterization – Load Pull Performance at 6.0 GHz

Test conditions unless otherwise noted:  $T_A = 25^\circ\text{C}$ ,  $V_D = 28\text{ V}$ ,  $I_{DQ} = 50\text{ mA}$ , Pulse: 100uS, 20%

Symbol	Parameter	Min	Typical	Max	Units
$G_{LIN}$	Linear Gain		11.3		dB
$P_{3dB}$	Output Power at 3 dB Gain Compression		19.0		W
$DE_{3dB}$	Drain Efficiency at 3 dB Gain Compression		66.0		%
$PAE_{3dB}$	Power-Added Efficiency at 3 dB Gain		56.2		%
$G_{3dB}$	Gain at 3 dB Compression		8.3		dB

### RF Characterization – Performance at 5.2 GHz <sup>(1)</sup>

Test conditions unless otherwise noted:  $T_A = 25\text{ }^\circ\text{C}$ ,  $V_D = 28\text{ V}$ ,  $I_{DQ} = 50\text{ mA}$ , Pulse: 100 $\mu\text{S}$ , 20%

Symbol	Parameter	Min	Typical	Max	Units
$G_{LIN}$	Linear Gain		10.5		dB
$P_{3dB}$	Output Power at 3 dB Gain Compression		17.3		W
$DE_{3dB}$	Drain Efficiency at 3 dB Gain Compression		48.0		%
$G_{3dB}$	Gain at 3 dB Compression		7.5		dB

Notes:

- Performance at 5.2 GHz in the 5.0 to 6.0 GHz Evaluation Board

### RF Characterization – Mismatch Ruggedness at 3.50 GHz <sup>(1)</sup>

Test conditions unless otherwise noted:  $T_A = 25\text{ }^\circ\text{C}$ ,  $V_D = 28\text{ V}$ ,  $I_{DQ} = 50\text{ mA}$

Symbol	Parameter	Typical
VSWR	Impedance Mismatch Ruggedness	10:1

Notes:

- $V_{DS} = 28\text{ V}$ ,  $I_{DQ} = 50\text{ mA}$ , CW at  $P_{1dB}$

### Thermal and Reliability Information – Pulsed

Parameter	Test Conditions	Value	Units
Thermal Resistance ( $\theta_{JC}$ )	Pdiss = 22.5W, Pulse width = 100 $\mu$ S, Duty cycle = 5%, Tbase = 85 $^{\circ}$ C	4.6	$^{\circ}$ C/W
Channel Temperature ( $T_{CH}$ )		188	$^{\circ}$ C
Median Lifetime ( $T_M$ )		4.9 E7	Hrs
Thermal Resistance ( $\theta_{JC}$ )	Pdiss = 22.5W, Pulse width = 100 $\mu$ S, Duty cycle = 10%, Tbase = 85 $^{\circ}$ C	4.7	$^{\circ}$ C/W
Channel Temperature ( $T_{CH}$ )		191	$^{\circ}$ C
Median Lifetime ( $T_M$ )		3.6 E7	Hrs
Thermal Resistance ( $\theta_{JC}$ )	Pdiss = 22.5W, Pulse width = 100 $\mu$ S, Duty cycle = 20%, Tbase = 85 $^{\circ}$ C	5.0	$^{\circ}$ C/W
Channel Temperature ( $T_{CH}$ )		198	$^{\circ}$ C
Median Lifetime ( $T_M$ )		1.9 E7	Hrs
Thermal Resistance ( $\theta_{JC}$ )	Pdiss = 22.5W, Pulse width = 100 $\mu$ S, Duty cycle = 50%, Tbase = 85 $^{\circ}$ C	5.6	$^{\circ}$ C/W
Channel Temperature ( $T_{CH}$ )		212	$^{\circ}$ C
Median Lifetime ( $T_M$ )		5.5 E6	Hrs

Notes:

Thermal resistance measured to bottom of package, Pulsed.

### Thermal and Reliability Information – CW

Parameter	Test Conditions	Value	Units
Thermal Resistance ( $\theta_{JC}$ )	Pdiss = 15W, Tbase = 85 $^{\circ}$ C	6.2	$^{\circ}$ C/W
Channel Temperature ( $T_{CH}$ )		178	$^{\circ}$ C
Median Lifetime ( $T_M$ )		1.3 E8	Hrs
Thermal Resistance ( $\theta_{JC}$ )	Pdiss = 17.5W, Tbase = 85 $^{\circ}$ C	6.5	$^{\circ}$ C/W
Channel Temperature ( $T_{CH}$ )		198	$^{\circ}$ C
Median Lifetime ( $T_M$ )		1.9 E7	Hrs
Thermal Resistance ( $\theta_{JC}$ )	Pdiss = 20W, Tbase = 85 $^{\circ}$ C	6.7	$^{\circ}$ C/W
Channel Temperature ( $T_{CH}$ )		219	$^{\circ}$ C
Median Lifetime ( $T_M$ )		3.0 E6	Hrs
Thermal Resistance ( $\theta_{JC}$ )	Pdiss = 22.5W, Tbase = 85 $^{\circ}$ C	7.0	$^{\circ}$ C/W
Channel Temperature ( $T_{CH}$ )		243	$^{\circ}$ C
Median Lifetime ( $T_M$ )		4.4 E5	Hrs

Notes:

Thermal resistance measured to bottom of package, CW.

**Median Lifetime**

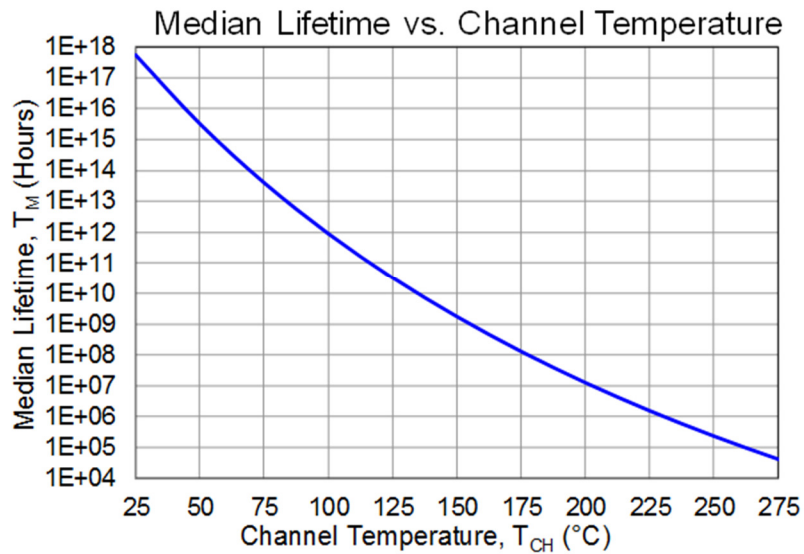

**Maximum Channel Temperature**

$T_{BASE} = 85^\circ\text{C}$ ,  $P_D = 22.5\text{ W}$

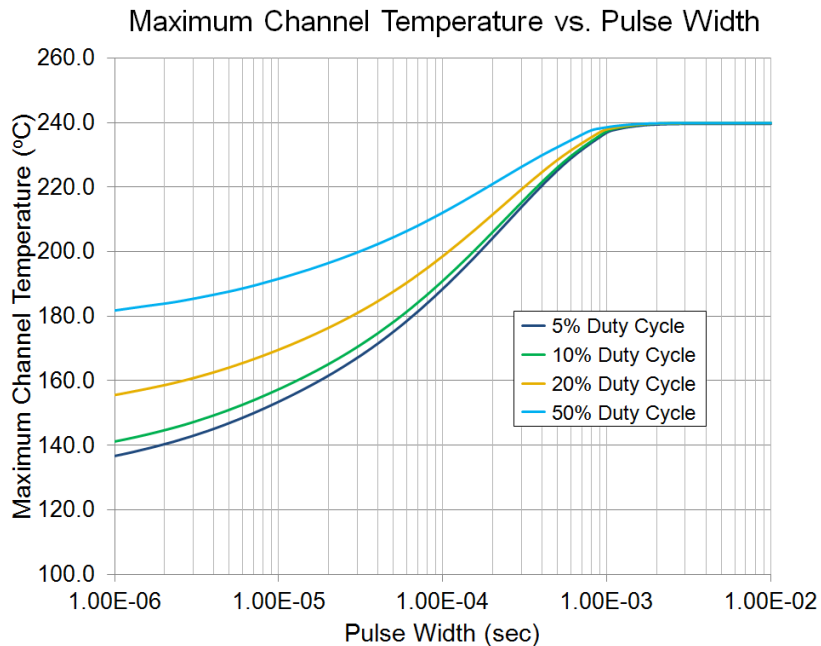

**Load Pull Smith Charts (1, 2)**

Notes:

1. The impedances shown are those presented to the device at load pull reference planes. See page 14.
2. Test Conditions:  $V_{DS} = 28\text{ V}$ ,  $I_{DQ} = 50\text{ mA}$
3. Test Signal: Pulse Width = 100  $\mu\text{sec}$ , Duty Cycle = 20%
4. NaN indicates the value was not set during load pull.
5.  $Z_0$  is characteristic impedance of load pull fixtures.

**3GHz, Load-pull**

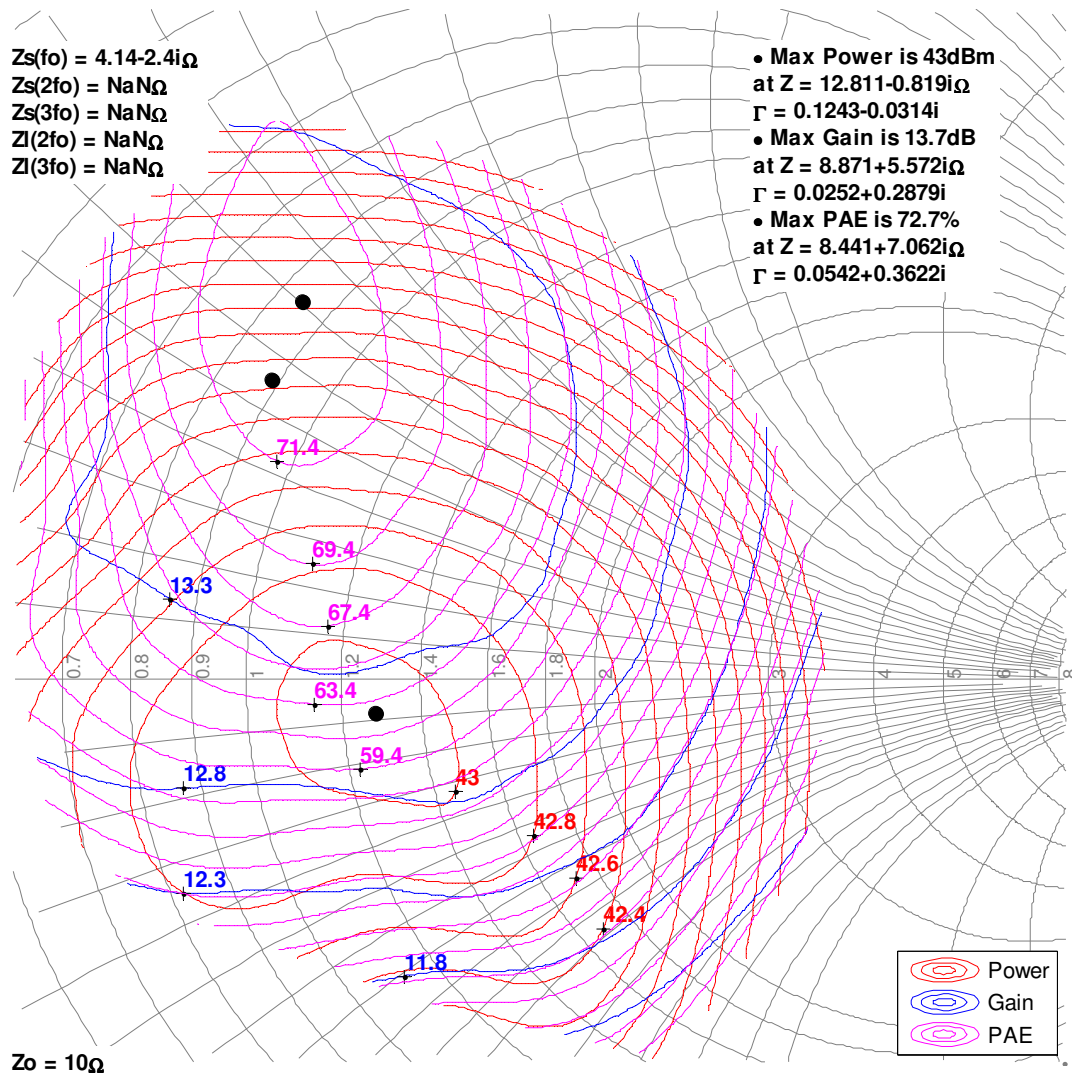

**Load Pull Smith Charts (1, 2)**

Notes:

1. The impedances shown are those presented to the device at load pull reference planes. See page 14.
2. Test Conditions:  $V_{DS} = 28\text{ V}$ ,  $I_{DQ} = 50\text{ mA}$
3. Test Signal: Pulse Width = 100  $\mu\text{sec}$ , Duty Cycle = 20%
4. NaN indicates the value was not set during load pull.
5.  $Z_0$  is characteristic impedance of load pull fixtures.

**4GHz, Load-pull**

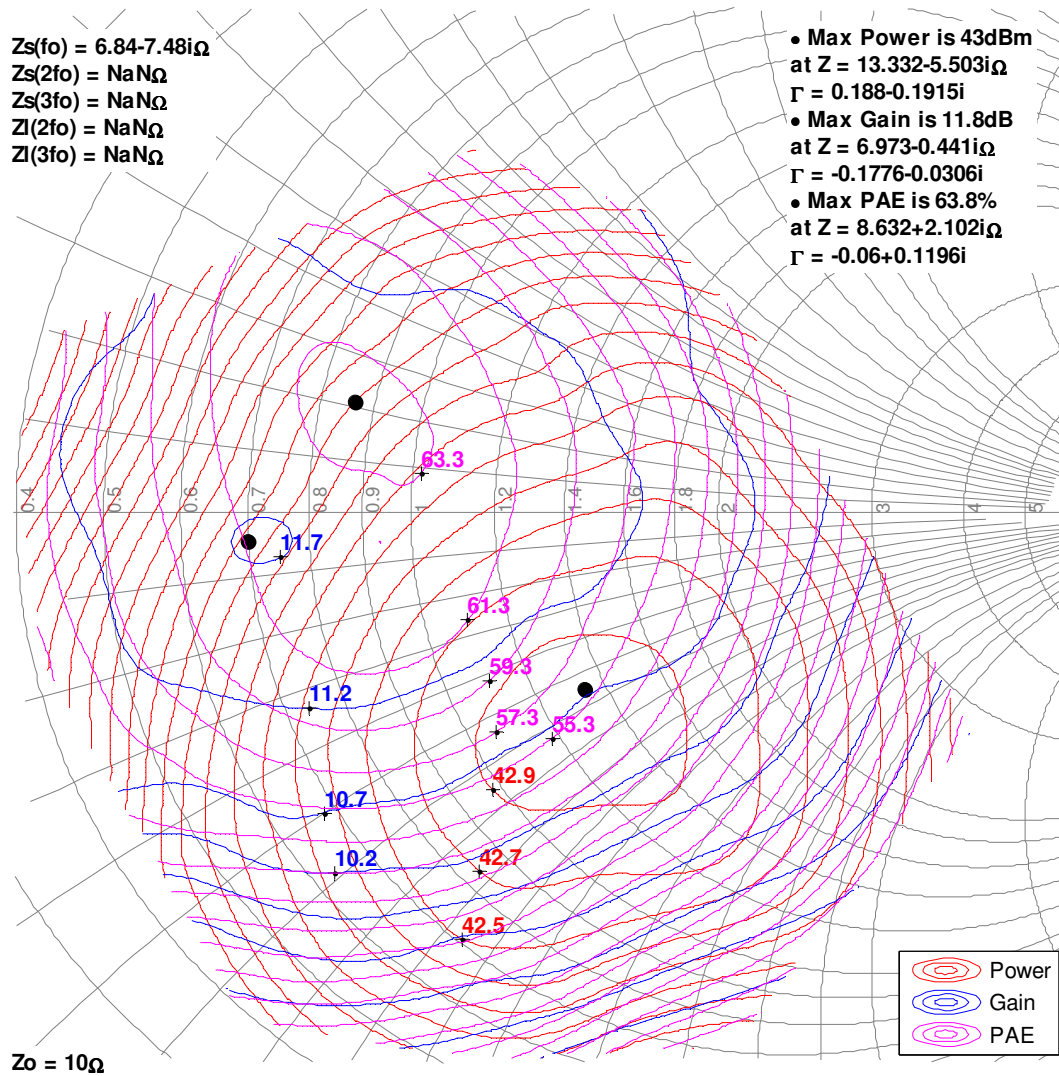

**Load Pull Smith Charts (1, 2)**

Notes:

1. The impedances shown are those presented to the device at load pull reference planes. See page 14.
2. Test Conditions:  $V_{DS} = 28\text{ V}$ ,  $I_{DQ} = 50\text{ mA}$
3. Test Signal: Pulse Width = 100  $\mu\text{sec}$ , Duty Cycle = 20%
4. NaN indicates the value was not set during load pull.
5.  $Z_0$  is characteristic impedance of load pull fixtures.

**5GHz, Load-pull**

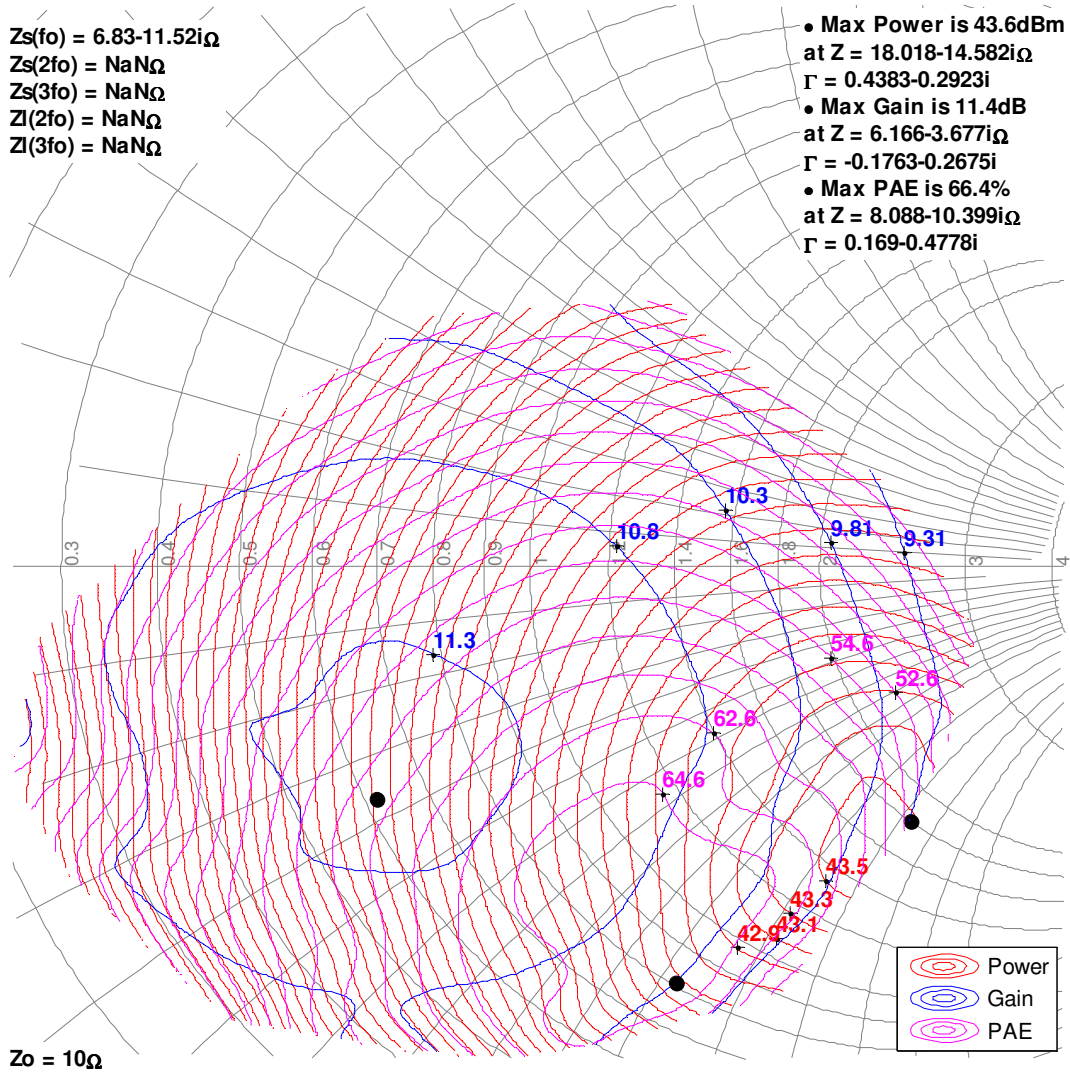



**Load Pull Smith Charts (1, 2)**

Notes:

1. The impedances shown are those presented to the device at load pull reference planes. See page 14.
2. Test Conditions:  $V_{DS} = 28\text{ V}$ ,  $I_{DQ} = 50\text{ mA}$
3. Test Signal: Pulse Width = 100  $\mu\text{sec}$ , Duty Cycle = 20%
4. NaN indicates the value was not set during load pull.
5.  $Z_0$  is characteristic impedance of load pull fixtures.

**6GHz, Load-pull**

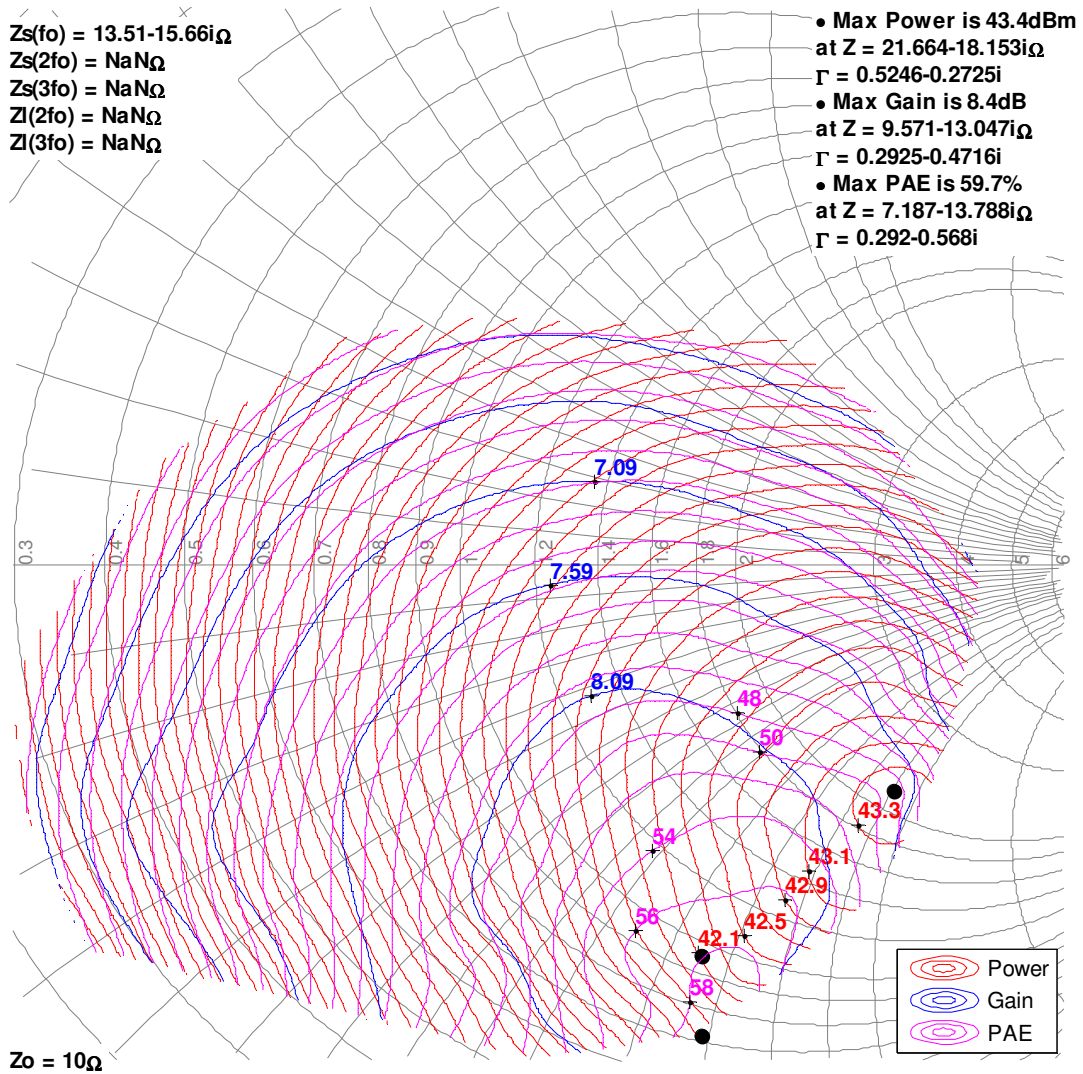

**Typical Performance**

Performance is based on compromised impedance point and measured at DUT reference planes. See page 14.

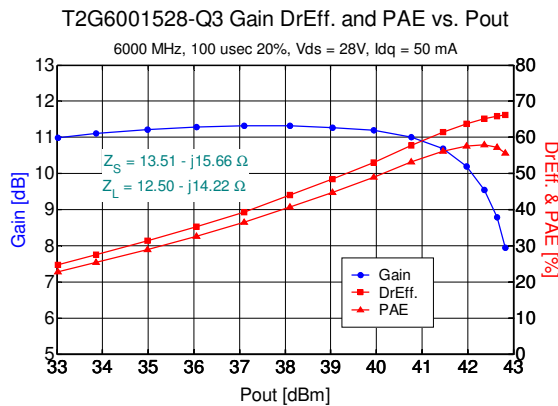
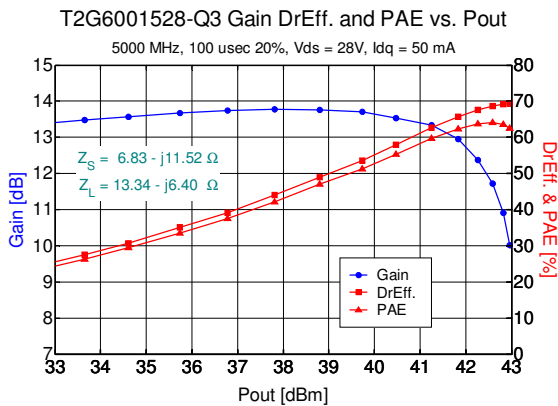
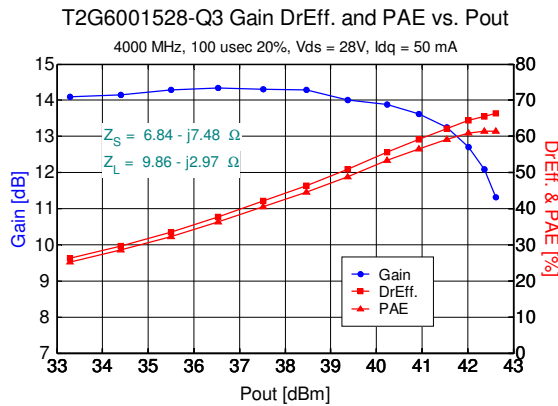
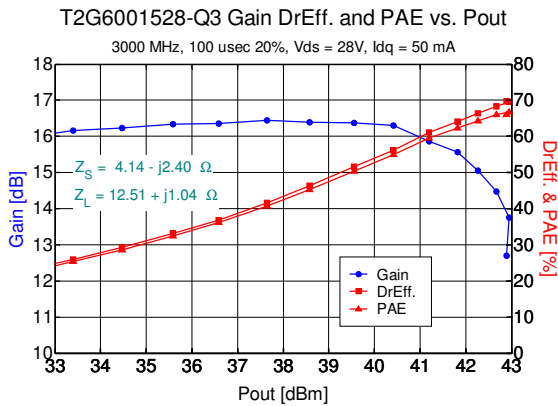
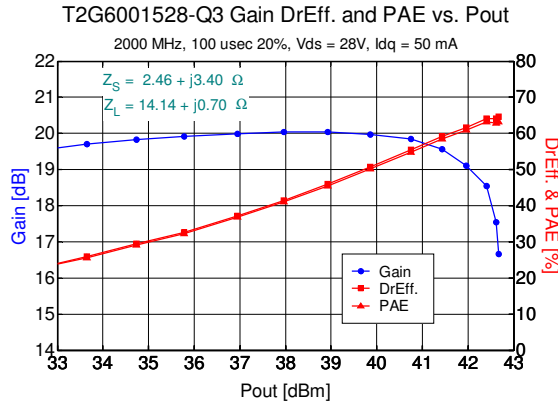
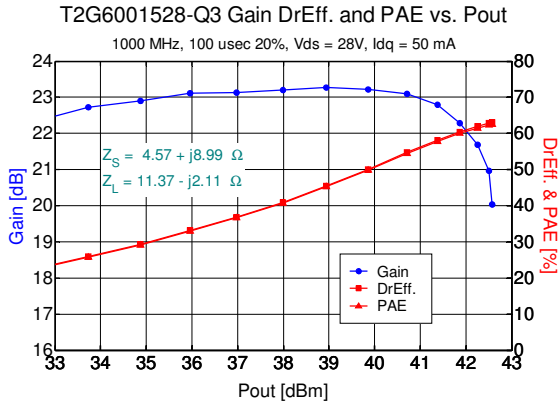

### Performance Over Temperature (1, 2)

Performance measured in TriQuint's 5.0 GHz to 6.0 GHz Evaluation Board at 3 dB compression.

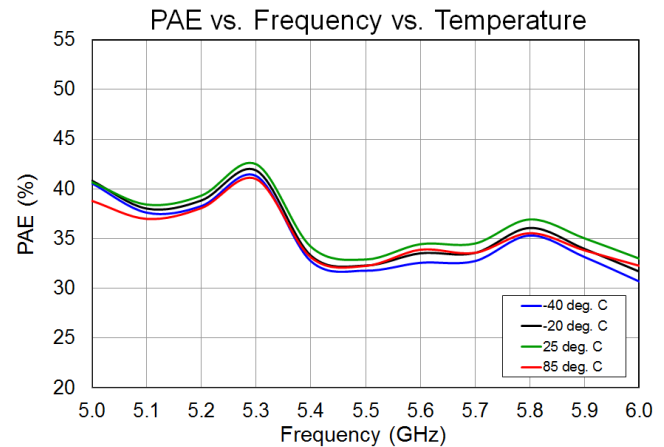
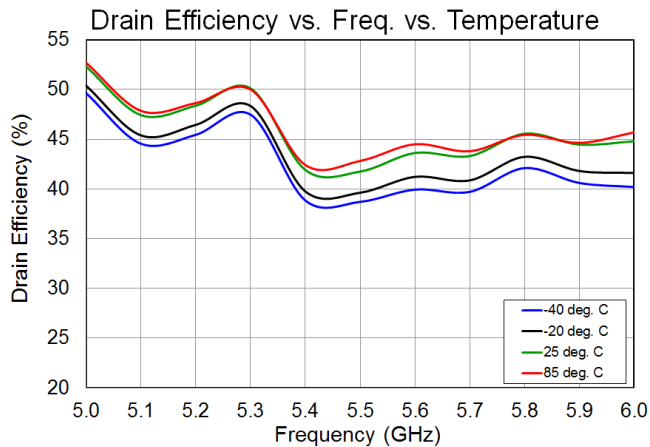
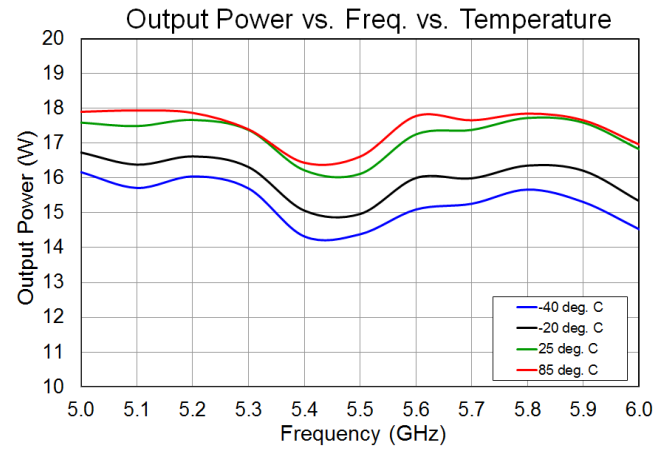
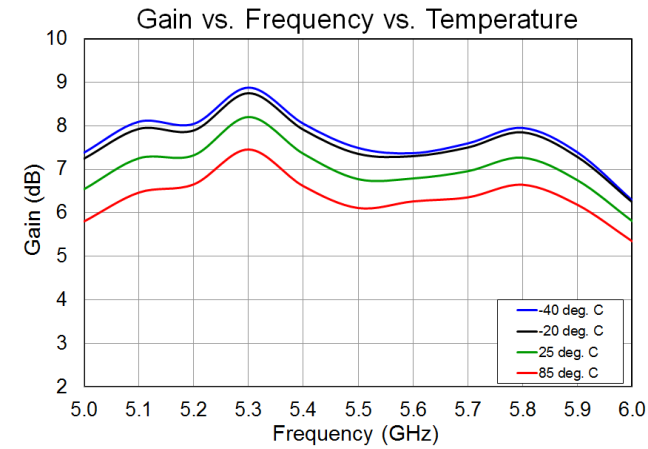

**Notes:**

1. Test Conditions:  $V_{DS} = 28\text{ V}$ ,  $I_{DQ} = 50\text{ mA}$
2. Test Signal: Pulse Width = 100  $\mu\text{s}$ , Duty Cycle = 20%

## Evaluation Board Performance (1, 2)

Performance at 3 dB Compression

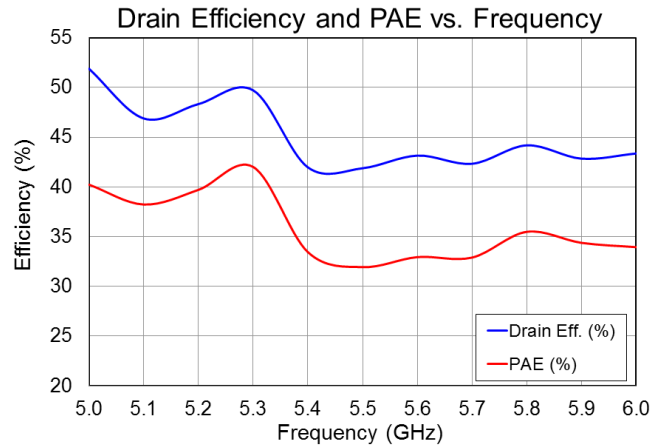
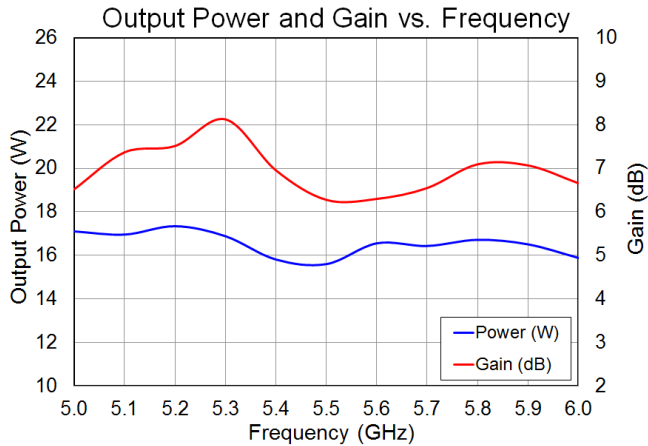

Notes:

1. Test Conditions:  $V_{DS} = 28\text{ V}$ ,  $I_{DQ} = 50\text{ mA}$
2. Test Signal: Pulse Width =  $100\text{ }\mu\text{s}$ , Duty Cycle = 20 %

## Application Circuit

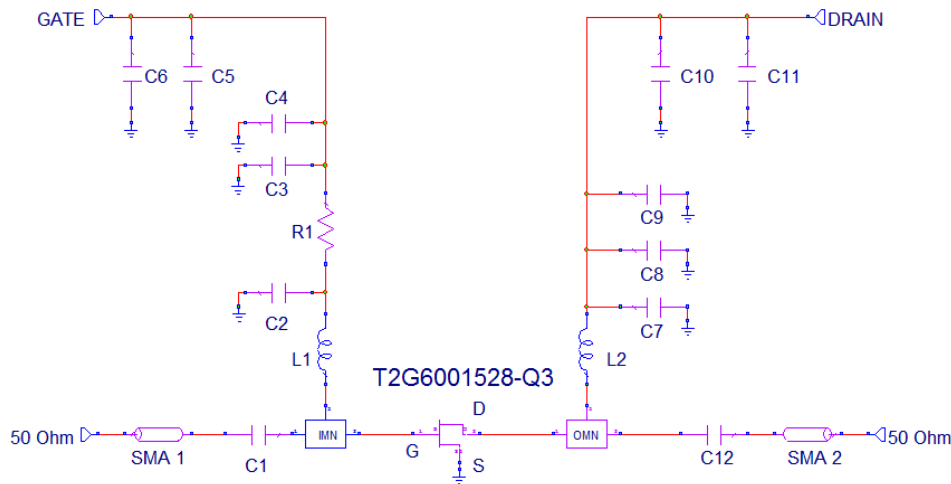

### Bias-up Procedure

- Set gate voltage ( $V_G$ ) to  $-5.0\text{ V}$
- Set drain voltage ( $V_D$ ) to  $28\text{ V}$
- Slowly increase  $V_G$  until quiescent  $I_D$  is  $50\text{ mA}$ .
- Apply RF signal

### Bias-down Procedure

- Turn off RF signal
- Turn off  $V_D$  and wait 1 second to allow drain capacitor dissipation
- Turn off  $V_G$

## Evaluation Board Layout

Top RF layer is 0.020" thick Rogers RO3203,  $\epsilon_r = 3.02$ . The pad pattern shown has been developed and tested for optimized assembly at TriQuint Semiconductor. The PCB land pattern has been developed to accommodate lead and package tolerances.

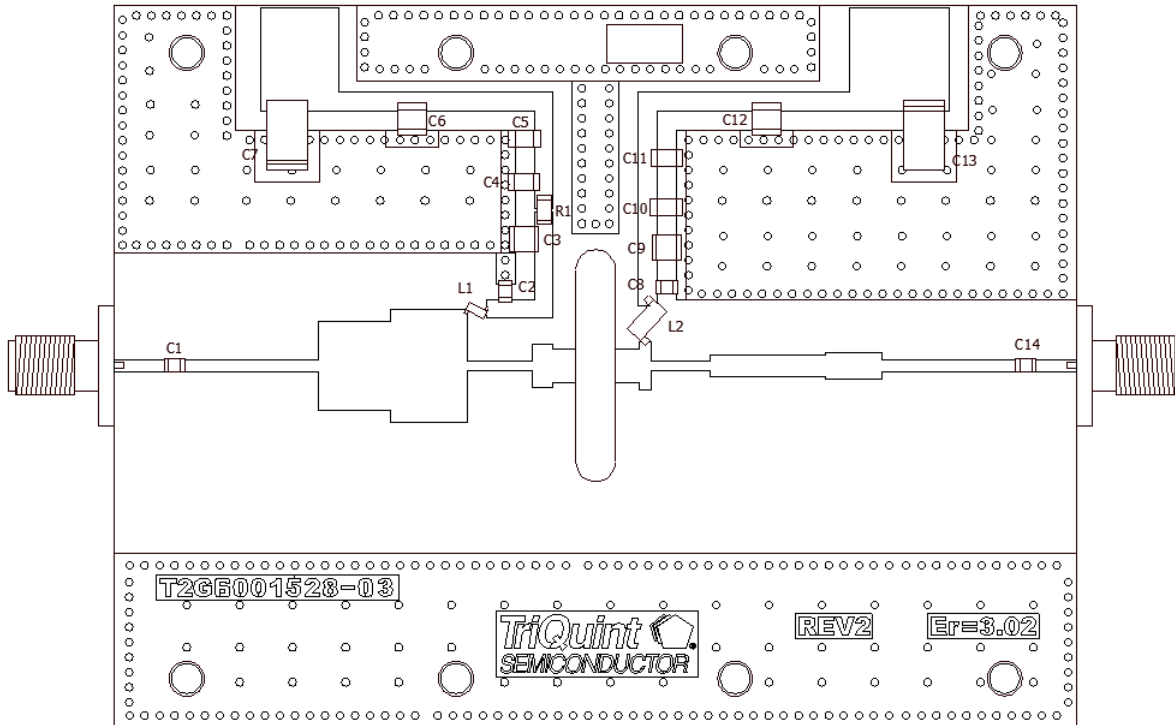

## Bill of Materials

Reference Design	Value	Qty	Manufacturer	Part Number
C1, C14	100 pF	2	ATC	100A101JW500XC
C2, C8	2400 pF	1	Dielectric Labs	C08BL242X-5UN-XOB
C3, C9	100 pF	2	ATC	100B101GT500X
C4, C10	0.01 uF	2	Kemet	C1206C103K1RACTU
C5, C11	0.1 uF	2	Kemet	C1206C104K1RACTU
C6, C12	1.0 uF	2	AVX	1812C105KAT2A
C7, C13	22 uF	2	Sprague	226K035AT
L1	5.4 nH	1	Coilcraft	0906-5JL
L2	9.85 nH	1	Coilcraft	1606-9JLB
R1	12.1Ohms	1	Vishay	CRC120612R1FKEA

**Pin Layout**

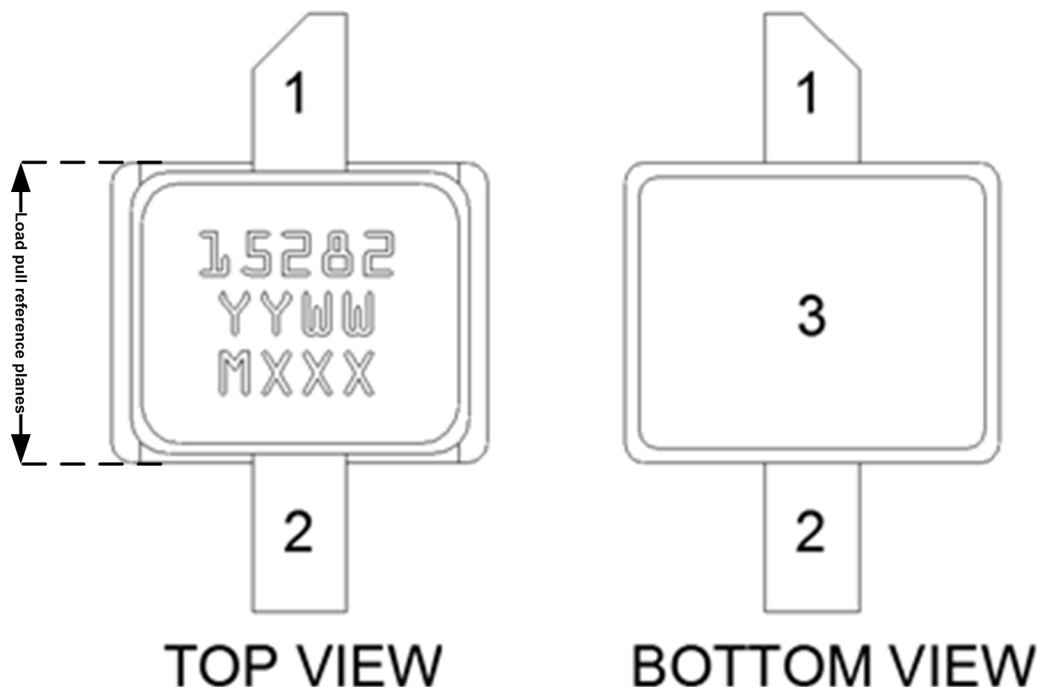

**Note:**

The T2G6001528-Q3 will be marked with the “15282” designator and a lot code marked below the part designator. The “YY” represents the last two digits of the calendar year the part was manufactured, the “WW” is the work week of the assembly lot start, and the “MXXX” is the production lot number.

**Pin Description**

Pin	Symbol	Description
1	$V_D$ / RF OUT	Drain voltage / RF Output matched to 50 ohms; see EVB Layout on page 9 as an example.
2	$V_G$ / RF IN	Gate voltage / RF Input matched to 50 ohms; see EVB Layout on page 9 as an example.
3	Flange	Source connected to ground; see EVB Layout on page 9 as an example.

**Notes:**

Thermal resistance measured to bottom of package

**Mechanical Information**

All dimensions are in millimeters. Unless specified otherwise, tolerances are  $\pm 0.127$ .

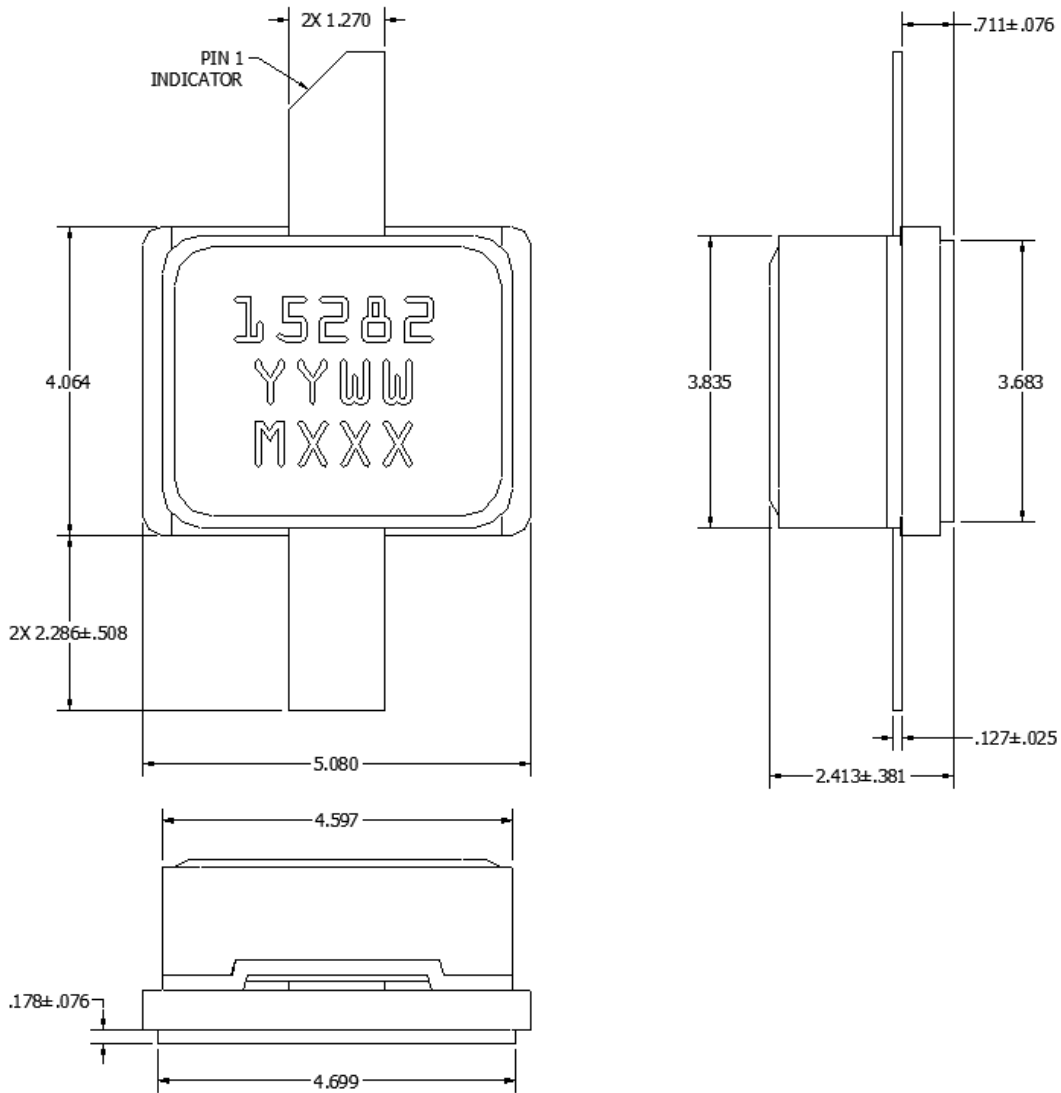

**Note:**

This package is lead-free/RoHS-compliant. The plating material on the leads is NiAu. It is compatible with both lead-free (maximum 260 °C reflow temperature) and tin-lead (maximum 245 °C reflow temperature) soldering processes.

## Product Compliance Information

### ESD Sensitivity Ratings



Caution! ESD-Sensitive Device

ESD Rating: Class 1A  
 Value: Passes  $\geq 250$  V to  $< 500$  V max.  
 Test: Human Body Model (HBM)  
 Standard: JEDEC Standard JESD22-A114

### MSL Rating

Level 3 at +260 °C convection reflow  
 The part is rated Moisture Sensitivity Level 3 at 260 °C per JEDEC standard IPC/JEDEC J-STD-020.

### ECCN

US Department of Commerce EAR99

### Solderability

Compatible with the latest version of J-STD-020, Lead free solder, 260 °C

### RoHS Compliance

This part is compliant with EU 2002/95/EC RoHS directive (Restrictions on the Use of Certain Hazardous Substances in Electrical and Electronic Equipment).

This product also has the following attributes:

- Lead Free
- Halogen Free (Chlorine, Bromine)
- Antimony Free
- TBBP-A (C<sub>15</sub>H<sub>12</sub>Br<sub>4</sub>O<sub>2</sub>) Free
- PFOS Free
- SVHC Free

## Recommended Soldering Temperature Profile

