

## Applications

- X-band radar

## Product Features

- Frequency Range: 8 – 11GHz
- $P_{OUT}$ : 48dBm @  $P_{IN} = 23dBm$
- PAE: 42% @  $P_{IN} = 23dBm$
- Large Signal Gain: 25dB
- Small Signal Gain: 31dB
- Return Loss: >10dB
- Bias:  $V_D = 28V$ ,  $I_{DQ} = 650mA$ ,  $V_G = -2.8V$  Typical
- Pulsed  $V_D$ :  $PW = 100\mu s$  and  $DC = 10\%$
- Chip Dimensions: 5.49 x 7.0 x 0.10 mm

## General Description

TriQuint's TGA2238 is a high power MMIC amplifier fabricated on TriQuint's production 0.25um GaN on SiC process. The TGA2238 operates from 8 – 11GHz and provides a superior combination of power, gain and efficiency by achieving more than 60W of saturated output power with 25dB of large signal gain and more than 42% power-added efficiency.

This superior performance provides system designers the flexibility to improve system performance while reducing size and cost.

The TGA2238 is matched to 50Ω with integrated DC blocking capacitor on RF input port simplifying system integration. It is ideally suited for military and commercial x-band radar systems.

Lead-free and RoHS compliant.

Evaluation boards are available upon request.

## Functional Block Diagram

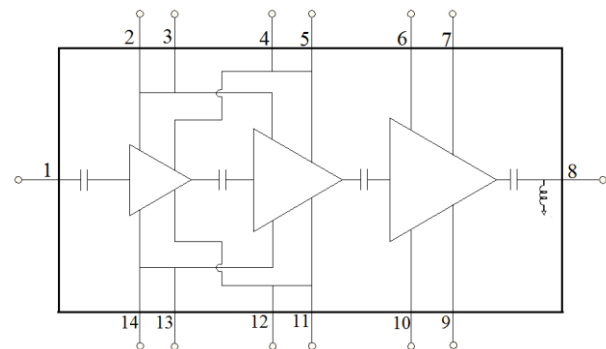

## Pad Configuration

Pad No.	Symbol
1	RF In
2, 14	$V_{G1}$
3, 13	$V_{G2}$
4, 12	$V_{D1}$
5, 11	$V_{D2}$
6, 10	$V_{G3}$
7, 9	$V_{D3}$
8	RF Out

## Ordering Information

Part	ECCN	Description
TGA2238	3A001.b.2.b	8 – 11GHz 60W GaN Power Amplifier

### Absolute Maximum Ratings

Parameter	Value
Drain Voltage ( $V_D$ )	40V
Gate Voltage Range ( $V_G$ )	-8 to 0V
Drain Current ( $I_D$ )	8A
Gate Current ( $I_G$ )	-26 to 62mA
Power Dissipation ( $P_{DISS}$ ), 85°C, Pulsed: PW = 100us; DC = 10%	158W
Input Power ( $P_{IN}$ ), 50Ω, $V_D = 25V$ , 85°C, Pulsed: PW = 100us; DC = 10%	30dBm
Input Power ( $P_{IN}$ ), VSWR 3:1, $V_D = 25V$ , 85°C; Pulsed: PW = 100us; DC = 10%	30dBm
Channel Temperature ( $T_{CH}$ )	275°C
Mounting Temperature (30 seconds)	320°C
Storage Temperature	-55 to 150°C

Operation of this device outside the parameter ranges given above may cause permanent damage. These are stress ratings only, and functional operation of the device at these conditions is not implied.

### Recommended Operating Conditions

Parameter	Value
Drain Voltage ( $V_D$ )	28V
Drain Current ( $I_{DQ}$ )	650mA (Total)
Gate Voltage ( $V_G$ )	-2.8V (Typ.)

Electrical specifications are measured at specified test conditions. Specifications are not guaranteed over all recommended operating conditions.

### Electrical Specifications

Test conditions unless otherwise noted: 25°C,  $V_D = 28V$ ,  $I_{DQ} = 650mA$ ,  $V_G = -2.8V$  Typical, Pulsed  $V_D$ : PW = 100us, DC = 10%

Parameter	Min	Typical	Max	Units
Operational Frequency Range	8		11	GHz
Small Signal Gain		31		dB
Input Return Loss		15		dB
Output Return Loss		15		dB
Power Gain ( $P_{in} = 23dBm$ )		25		dB
Output Power ( $P_{in} = 23dBm$ )		48		dBm
Power Added Efficiency ( $P_{in} = 23dBm$ )		42		%
Power @ 1dB Compression ( $P_{1dB}$ )		36		dBm
Small Signal Gain Temperature Coefficient		-0.058		dB/°C
Output Power Temperature Coefficient		-0.014		dBm/°C

**Thermal and Reliability Information**

Parameter	Test Conditions	Value	Units
Thermal Resistance ( $\theta_{JC}$ ) <sup>(1)</sup>	$T_{base} = 85^{\circ}C$ , Pulsed $V_D$ : PW = 100us, DC = 10%	0.84	$^{\circ}C/W$
Channel Temperature ( $T_{CH}$ ) (Under RF drive)	$V_D = 25V$ , $I_{D\_Drive} = 6A$ , Freq=9.25GHz	162	$^{\circ}C$
Median Lifetime ( $T_M$ )	$P_{IN} = 25dBm$ , $P_{OUT} = 47.8dBm$ , $P_{DISS} = 92W$	$4.48 \times 10^9$	Hrs
Thermal Resistance ( $\theta_{JC}$ ) <sup>(1)</sup>	$T_{base} = 85^{\circ}C$ , Pulsed $V_D$ : PW = 100us, DC = 10%	0.87	$^{\circ}C/W$
Channel Temperature ( $T_{CH}$ ) (Under RF drive)	$V_D = 28V$ , $I_{D\_Drive} = 6.3A$ , Freq = 9.25GHz	178	$^{\circ}C$
Median Lifetime ( $T_M$ )	$P_{IN} = 25dBm$ , $P_{OUT} = 48.3dBm$ , $P_{DISS} = 107W$	$9.7 \times 10^8$	Hrs

Notes:

1. Thermal resistance measured to back of carrier plate. MMIC mounted on 40 mils CuMo (80/20) carrier using 1.5 mil AuSn.

Test Conditions:  $V_D = 40V$ ; Failure Criteria = 10% reduction in  $I_{D\_MAX}$

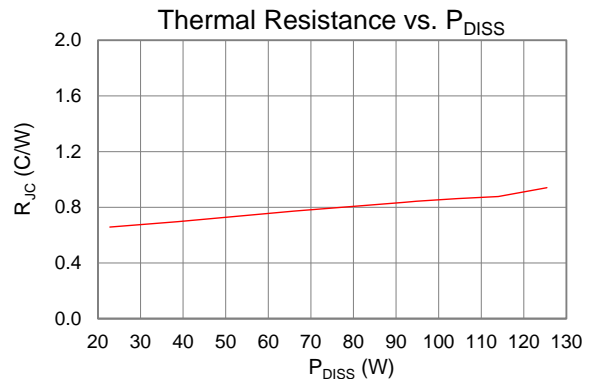
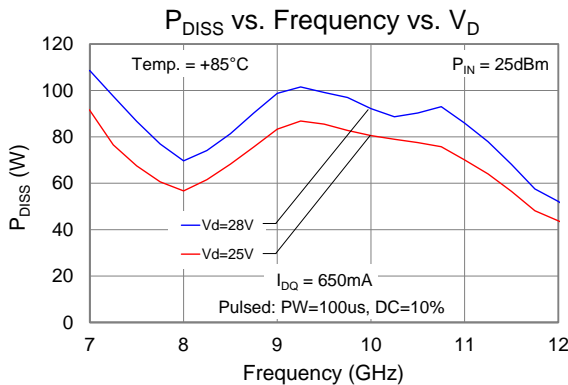
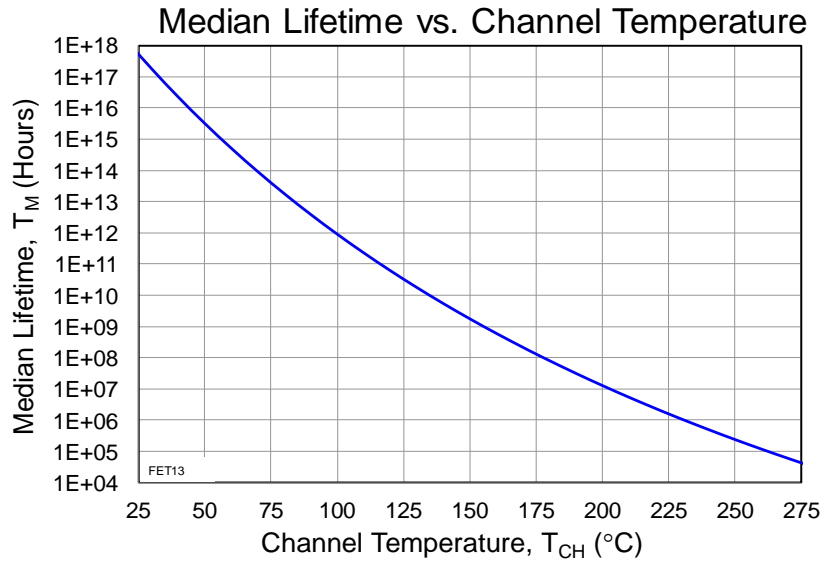

**Typical Performance (Small Signal)**

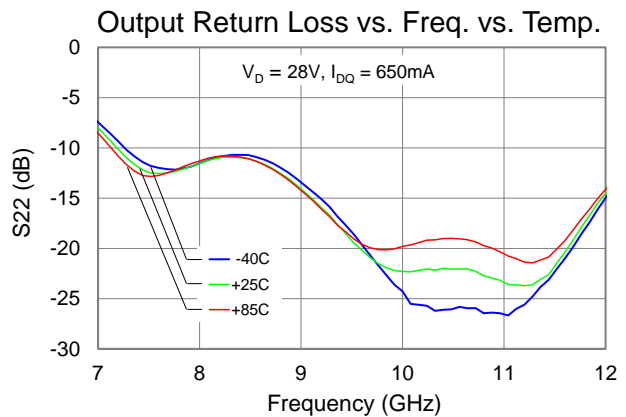
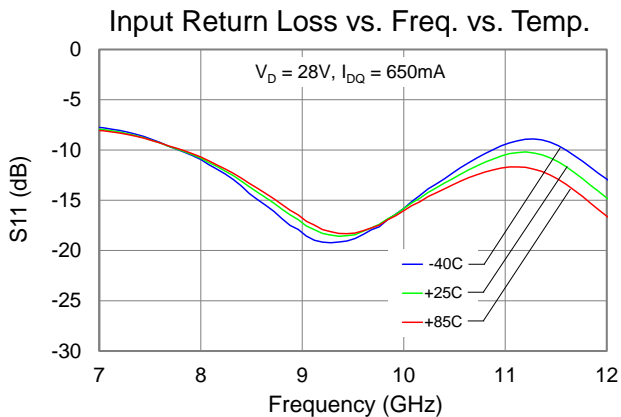
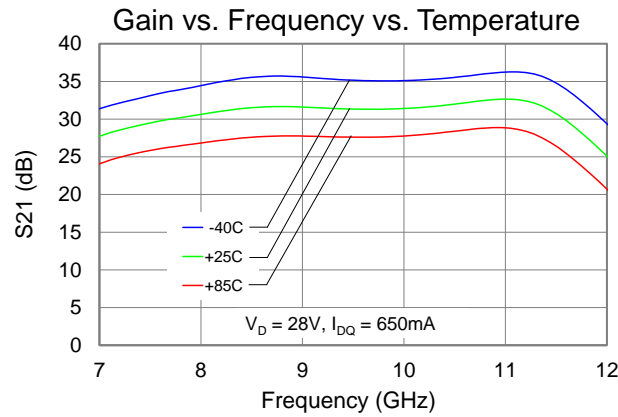
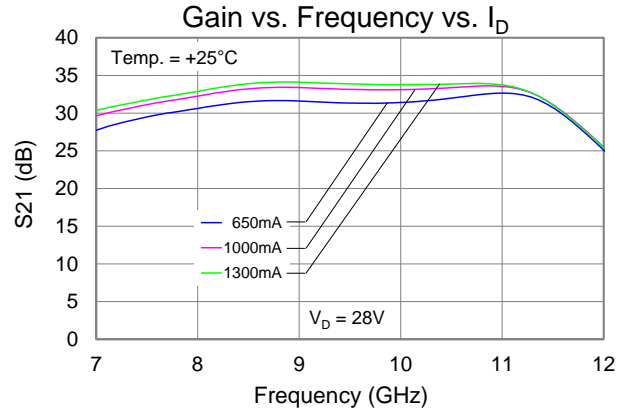
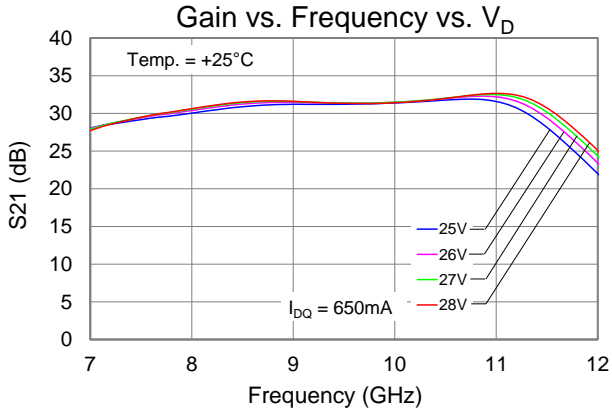

Typical Performance (Pulsed Operation)

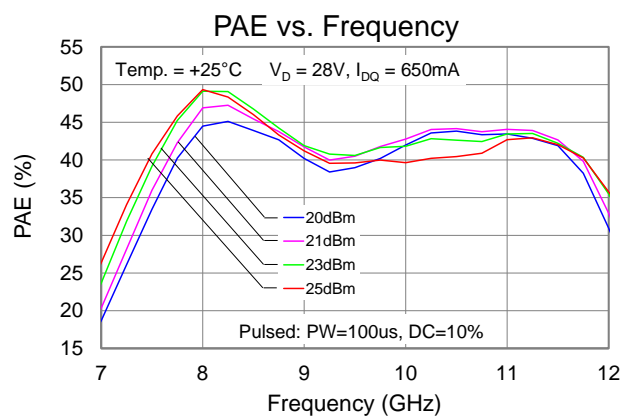
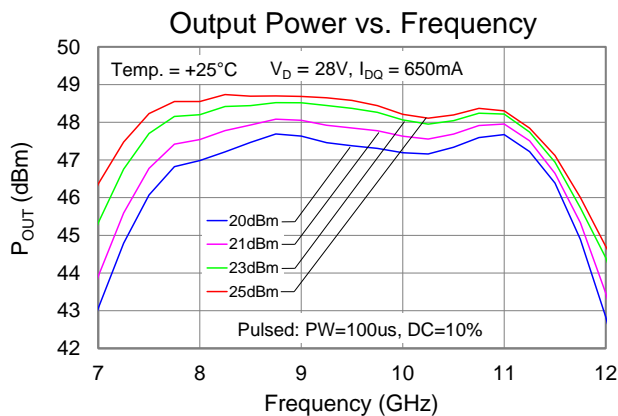
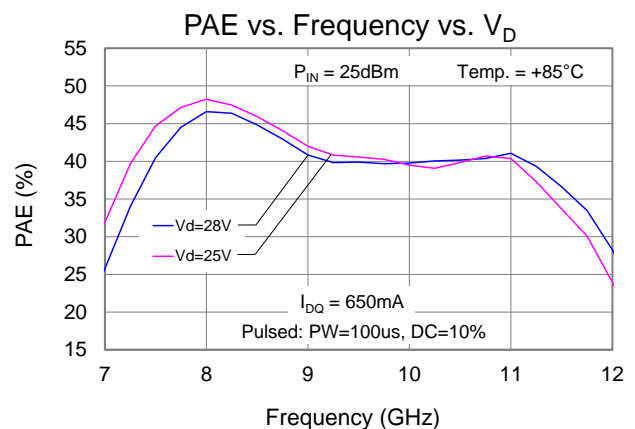
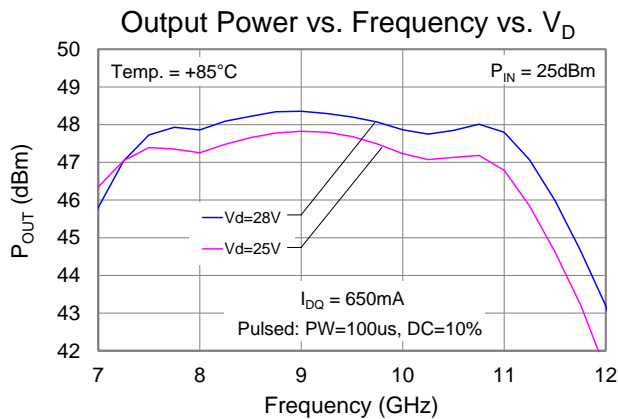
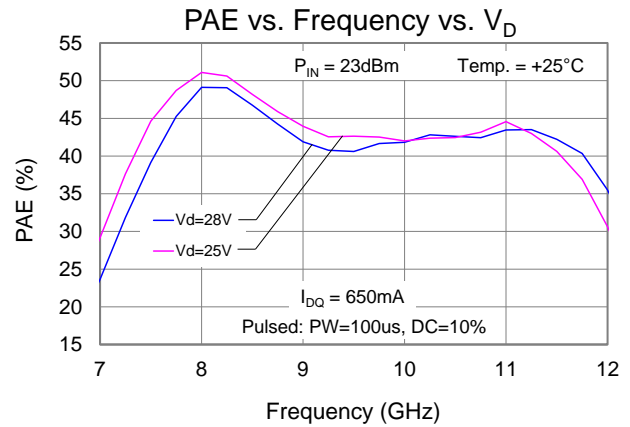
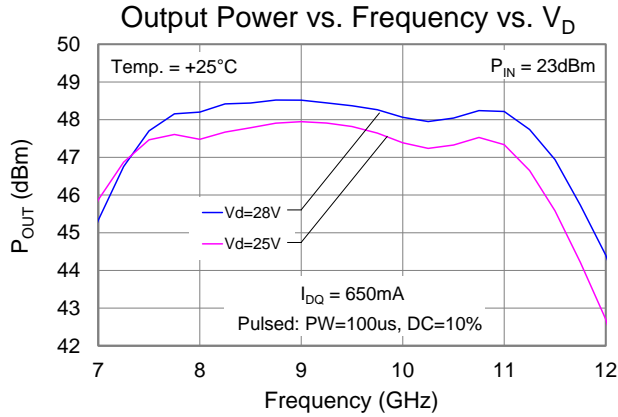

**Typical Performance (Pulsed Operation)**

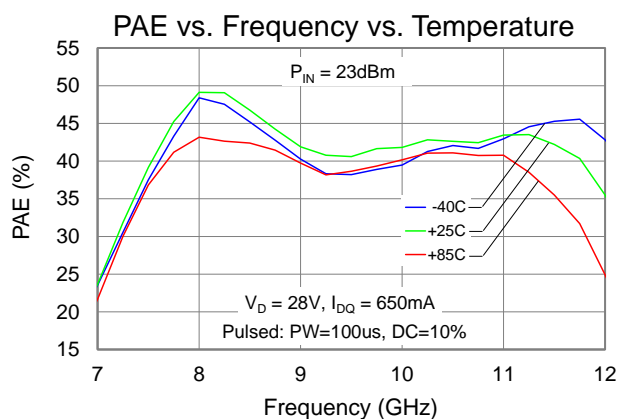
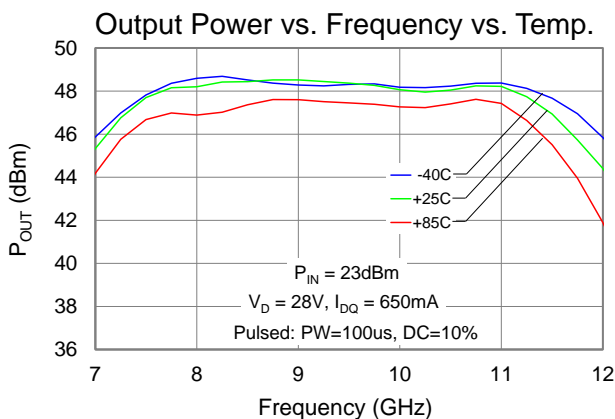
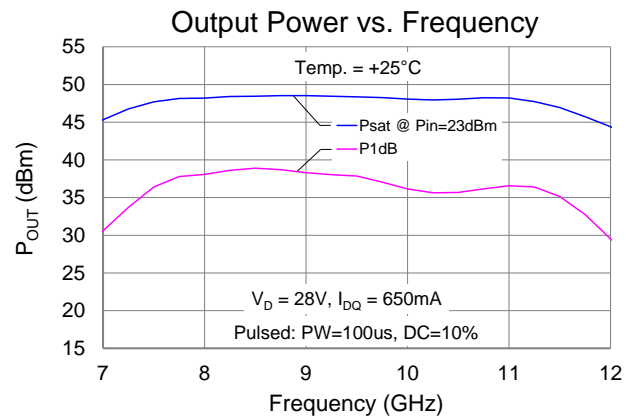
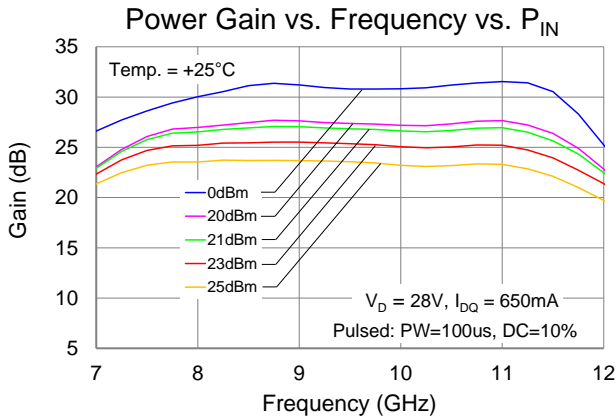
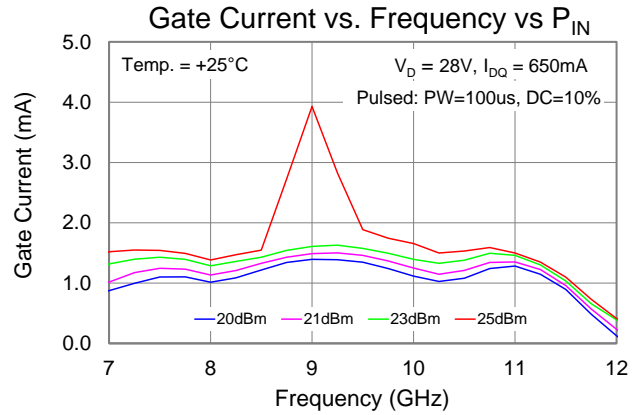
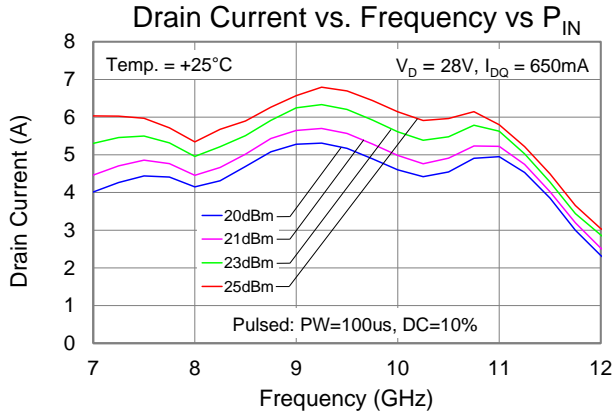

**Typical Performance (Pulsed Operation)**

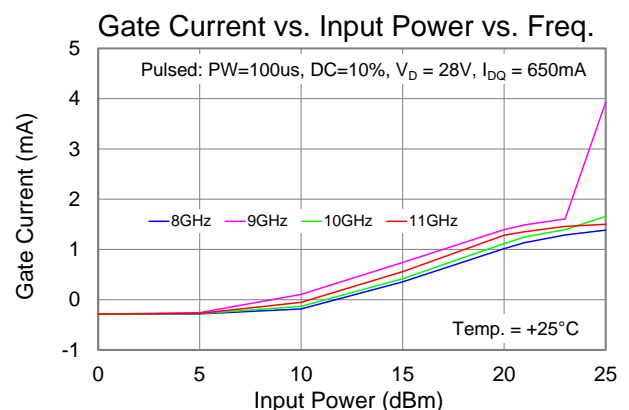
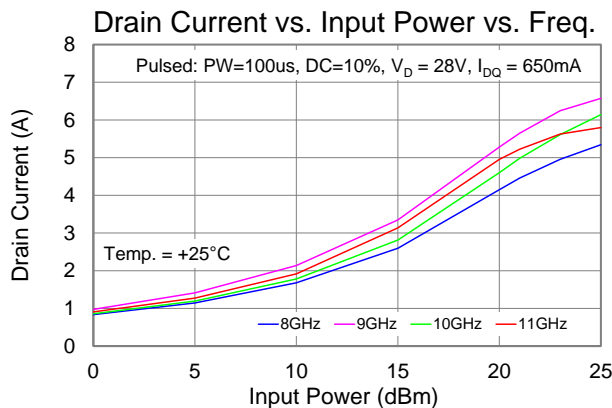
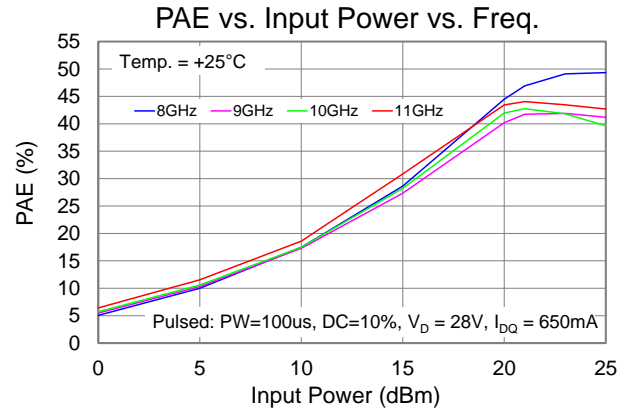
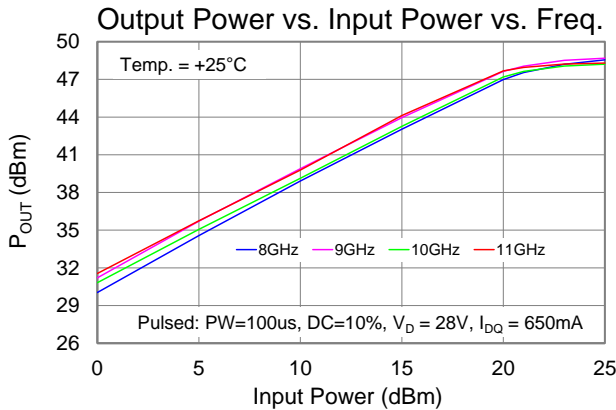
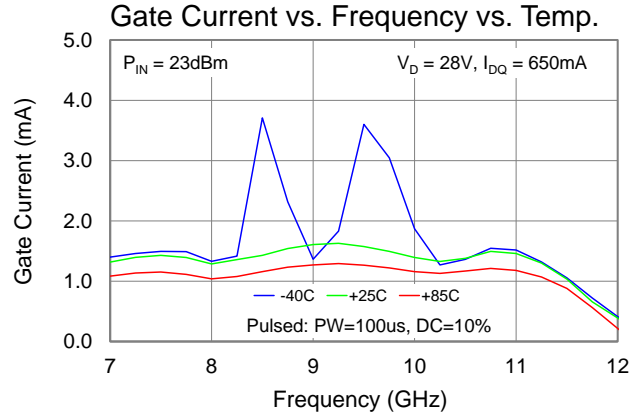
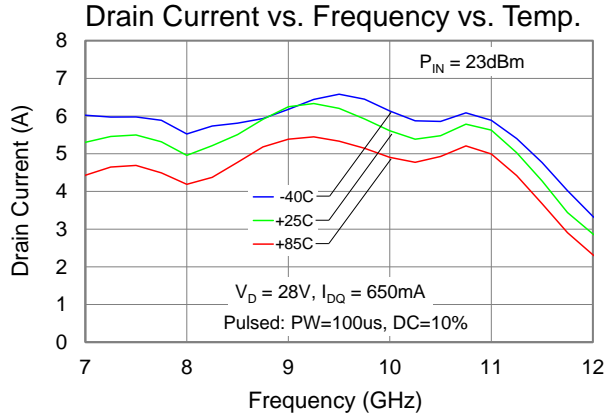

Application Circuit

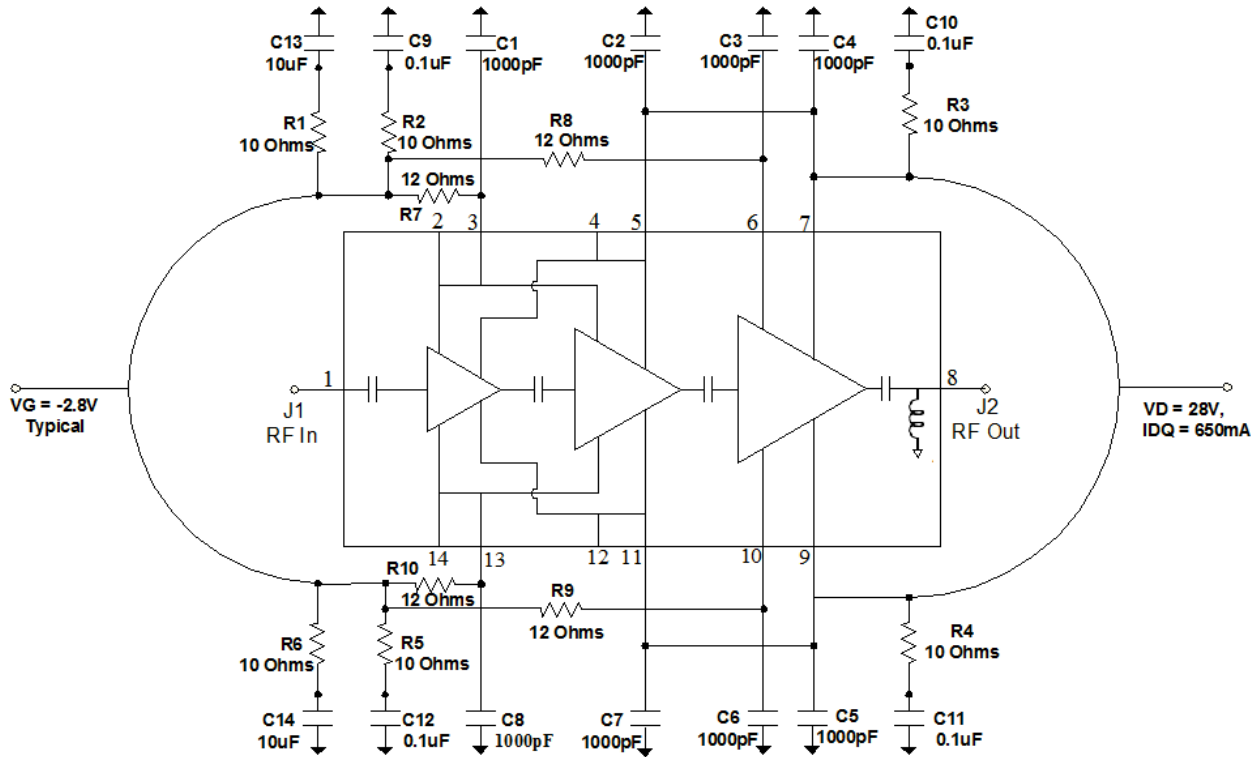

Bias-up Procedure

1. Set  $I_D$  limit to 8A,  $I_G$  limit to 20mA
2. Set  $V_G$  to -5.0V
3. Set  $V_D$  +28V
4. Adjust  $V_G$  more positive until  $I_{DQ} = 650mA$  ( $V_G \sim -2.8V$  Typical)
5. Apply RF signal

Bias-down Procedure

1. Turn off RF signal
2. Reduce  $V_G$  to -5.0V. Ensure  $I_{DQ} \sim 0mA$
3. Set  $V_D$  to 0V
4. Turn off  $V_D$  supply
5. Turn off  $V_G$  supply



Evaluation Board (EVB) Layout Assembly

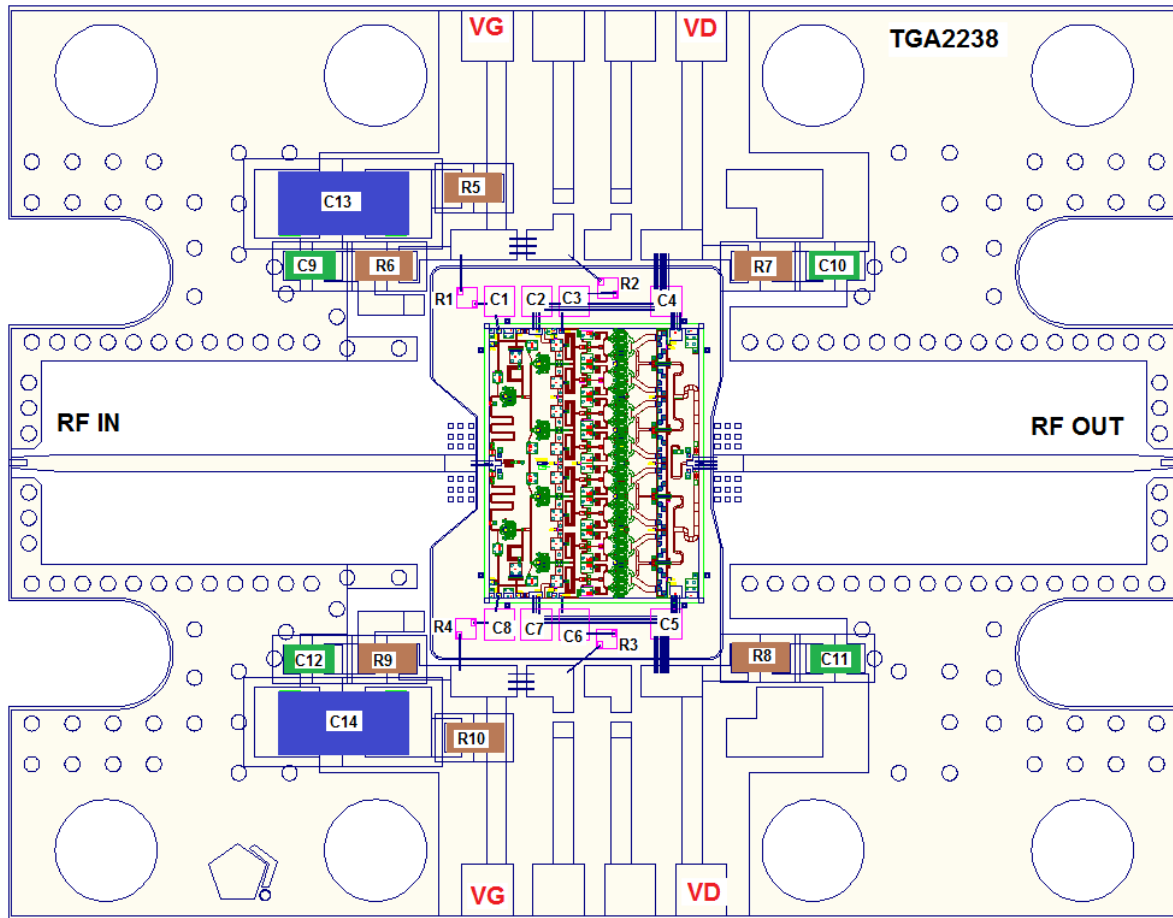

Bill of Materials

Reference Design	Value	Description	Manufacturer	Part Number
C1 – C8	1000pF	SLC, 50V	Various	
C9 – C12	0.1uF	Cap, 0402, 50V, 10%, X7R	Various	
C13 – C14	10uF	Cap, 1206, 50V, 20%, X5R	Various	
R1 – R4	12Ω	Single Layer Resistor	Various	
R5 – R10	10Ω	Res, 0402	Various	

**Mechanical Drawing & Bond Pad Description**

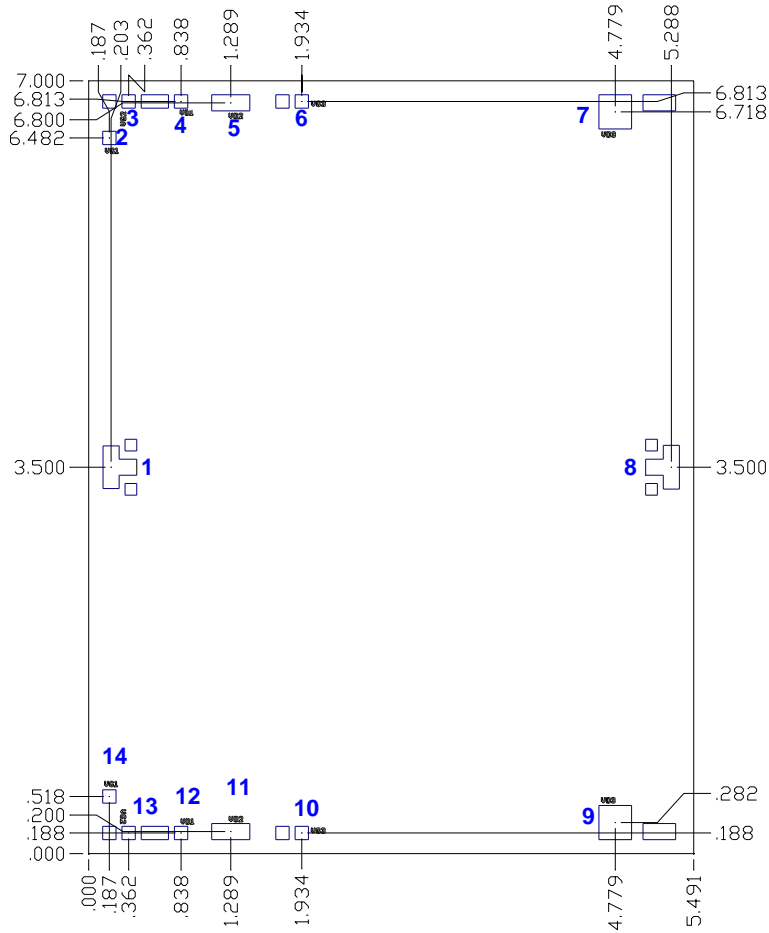

Unit: millimeters  
 Thickness: 0.10  
 Die x, y size tolerance: +/- 0.050  
 Chip edge to bond pad dimensions are shown to center of pad  
 Ground is backside of die

Bond Pad Symbol	Pad Size	Description
1	RF In	0.146 x 0.386 RF Input; matched to 50Ω; DC blocked
2, 14	VG1	0.121 x 0.121 VG1 and VG2 are internally connected so either one can be used for both VG1 or VG2, bias network is required; see Application Circuit on page 8 as an example.
3, 13	VG2	0.121 x 0.121
4, 12	VD1	0.121 x 0.121 VD1 and VD2 are internally connected so either one can be used for both VD1 or VD2, bias network is required; see Application Circuit on page 8 as an example.
5, 11	VD2	0.346 x 0.146
6, 10	VG3	0.121 x 0.121 Gate voltage 3, bias network is required; see Application Circuit on page 8 as an example.
7, 9	VD3	0.296 x 0.310 Drain voltage 3, bias network is required; see Application Circuit on page 8 as an example.
8	RF Out	0.146 x 0.386 RF Output; matched to 50Ω; DC shorted to ground

## Assembly Notes

Component placement and adhesive attachment assembly notes:

- Vacuum pencils and/or vacuum collets are the preferred method of pick up.
- Air bridges must be avoided during placement.
- The force impact is critical during auto placement.
- Organic attachment (i.e. epoxy) can be used in low-power applications.
- Curing should be done in a convection oven; proper exhaust is a safety concern.

Reflow process assembly notes:

- Use AuSn (80/20) solder and limit exposure to temperatures above 300°C to 3-4 minutes, maximum.
- An alloy station or conveyor furnace with reducing atmosphere should be used.
- Do not use any kind of flux.
- Coefficient of thermal expansion matching is critical for long-term reliability.
- Devices must be stored in a dry nitrogen atmosphere.

Interconnect process assembly notes:

- Thermosonic ball bonding is the preferred interconnect technique.
- Force, time, and ultrasonic are critical parameters.
- Aluminum wire should not be used.
- Devices with small pad sizes should be bonded with 0.0007-inch wire.