

THIS DRAWING IS UNPUBLISHED. RELEASED FOR PUBLICATION JUN, 1998.  
 © COPYRIGHT 1998 By - ALL RIGHTS RESERVED.

LOC	DIST	REVISIONS 変更					
J	/	P	LTR	DESCRIPTION	DATE	DWN	APVD
		E1		REVISED PER ECO-11-005030	11MAR11	RK	HMR

表1 TABLE 1

トレードマーク TRADE MARK	生産場所 MANUFACTURING LOCATION
AMP	シンガポール SINGAPORE
TE	中国 CHINA

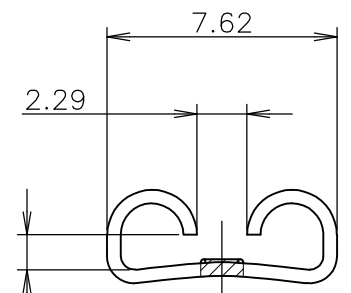
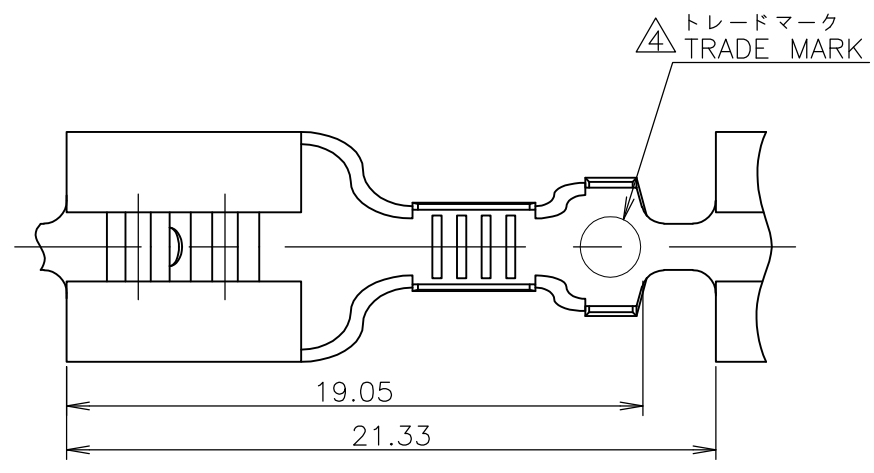

この寸法は嵌合力によって管理する。  
BE CONTROLLED BY MATING FORCE

VIEW A-A  
矢視

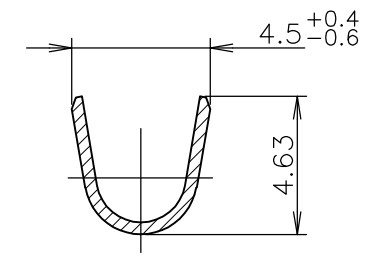
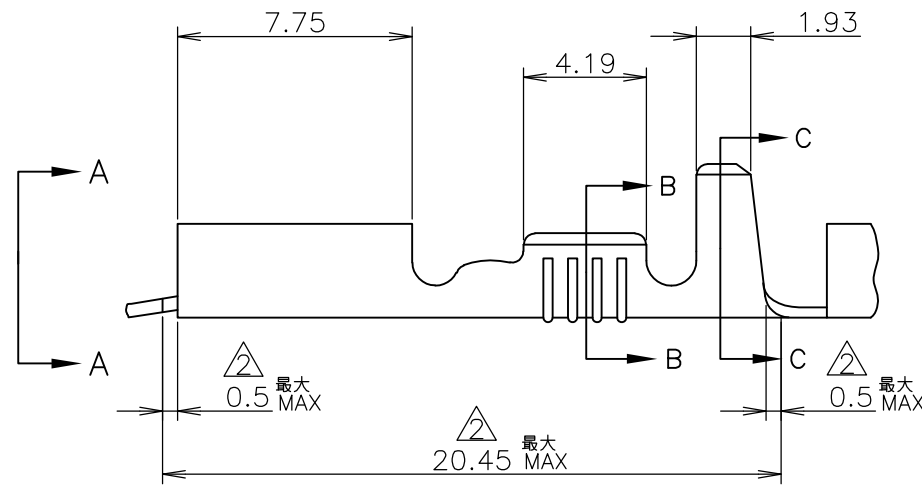

C-C

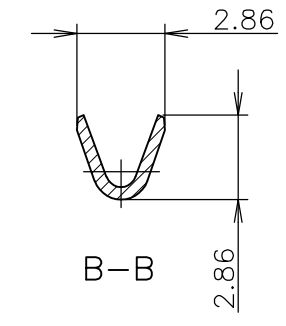

B-B

- 1 嵌合するファストンタブの詳細については#CP63-048Jの図面を参照の事
- ② LP型番の時のカット位置を示す
- ③ ストレス除去処理  
処理法により外観が変わります。  
不活性ガス加熱方式・・・無光沢  
大気加熱方式・・・・・・・・光沢
- ④ 表1参照

- 1 SEE DWG CP63-048J FOR THE DETAIL OF MATING TAB
- ② INDICATE CUT DIMENSION FOR LOOSE PIECE PART
- ③ STRESS RELIEVING  
FINISH IS SUBJECT TO CHANGE BY THE TYPE OF  
STRESS RELIEVING PROCESS  
INERT GAS FURNACE-----MATTE  
ATMOSPHERIC FURNACE FOLLOWED BY ACID PICKLE---BRIGHT
- ④ SEE TABLE 1

108-5178	TIN PLT 錫めっき	170187-2	BRASS 0.4 THK 黄銅 板厚 0.4	170183-2
108-5006	—H— ③	170187-1	BRASS 0.4 THK 黄銅 板厚 0.4	170183-1
PRODUCT SPEC 製品規格	FINISH 仕上	L.P.NO. LP型番(ワイヤパレルが プリフォーム)	MATERIAL 材質	P/N 型番

WIRE RANGE 抱合電線断面積 AWG #22-#18 0.30~0.89 mm<sup>2</sup>  
 INSULATION DIA 被覆外径 (.090-.130IN) 2.29~3.3 mm $\phi$

THIS DRAWING IS A CONTROLLED DOCUMENT.		DWN M.SUZUKI 04JUN1998	TE Connectivity 250 SERIES FASTON RECEPTACLE 250 シリーズ ファストン リセプタクル	
DIMENSIONS: 単位: 耗 mm		CHK M.SHINDO 04JUN1998		
TOLERANCES UNLESS OTHERWISE SPECIFIED: 一般公差		APVD S.KUBOUCHI 04JUN1998	NAME 名称	
0-PLC ± 1-PLC ± 2-PLC ± 3-PLC ± 4-PLC ± ANGLES ±		PRODUCT SPEC 表参照 製品規格 SEE TABLE	SIZE	
MATERIAL 表参照 材料 SEE TABLE		APPLICATION SPEC 取付適用規格 114-5084	CAGE CODE 00779	DRAWING NO 番号 C-170183
FINISH 表参照 仕上 SEE TABLE		WEIGHT	RESTRICTED TO	
CUSTOMER DRAWING		SCALE 尺度 4:1		SHEET 1 OF 1
		REV E1		