

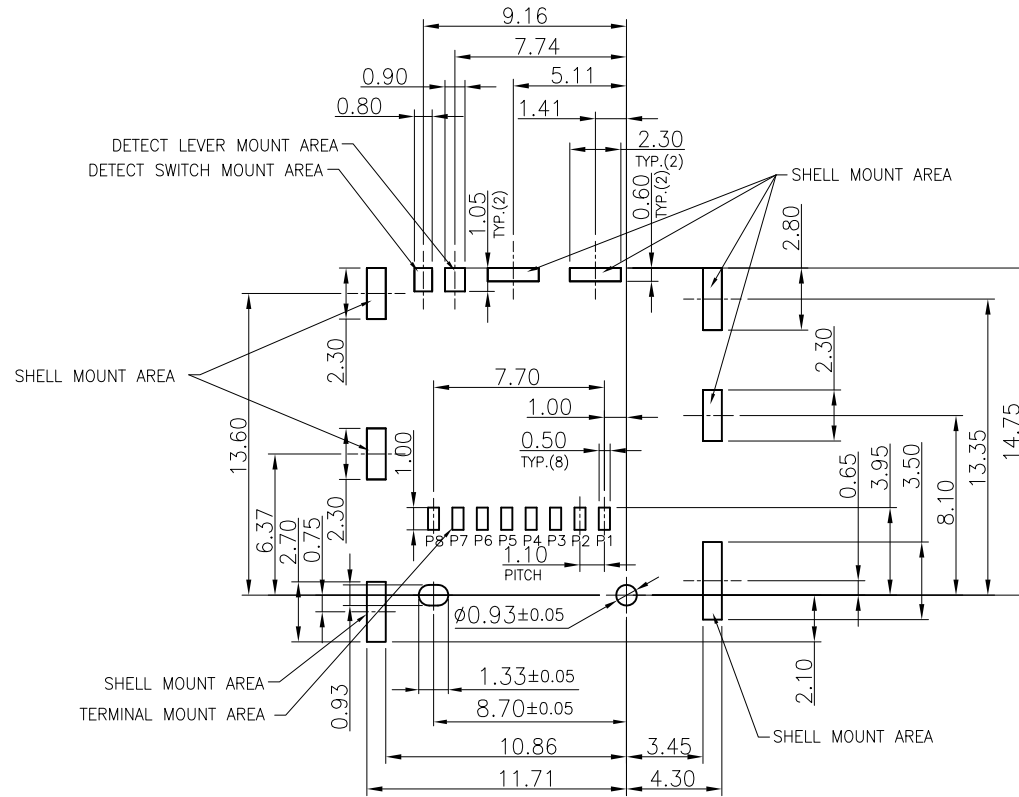

REV.	ECN NO OR DESCRIPTION	REVISED	DATE
▽	PROPOSE ONLY	ALLEN	2015.12.04

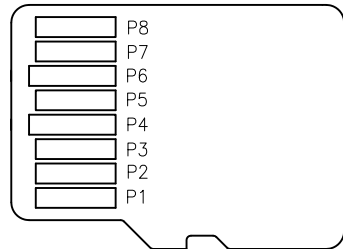

SUGGEST PCB THICKNESS 0.7MM MIN  
TOLERANCE: +/-0.05



MSD CARD ELECTRICAL

CONNECTOR PIN ASSIGNMENT:

ITEM	FUNCTION
MICRO SD CARD	
P1	DAT2 OF MSD
P2	CD/DAT3 OF MSD
P3	CMD OF MSD
P4	VDD OF MSD
P5	CLK OF MSD
P6	VSS OF MSD
P7	DAT0 OF MSD
P8	DAT1 OF MSD
SC	SW CONTACT
SS	SW SPRING

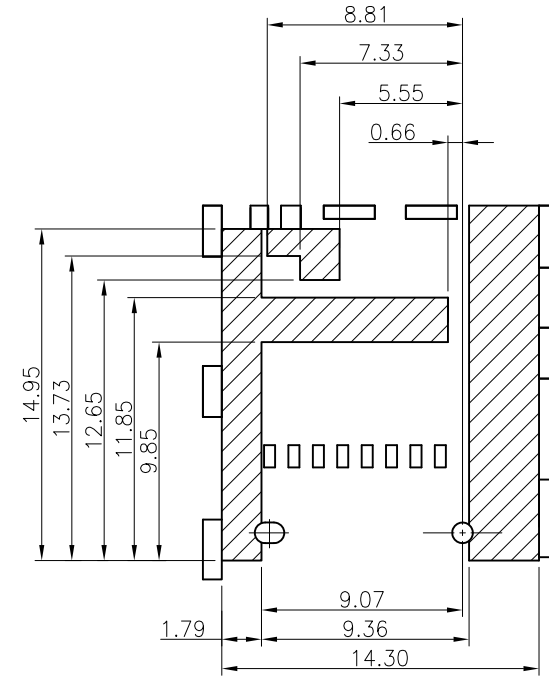

PATTERN KEEP OUT AREA  
TOLERANCE: +/-0.05  
GND RECOMMENDED PATTERN

CIRCUIT DIAGRAM FOR DETECT SWITCHES

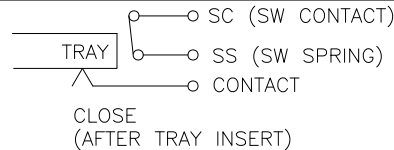
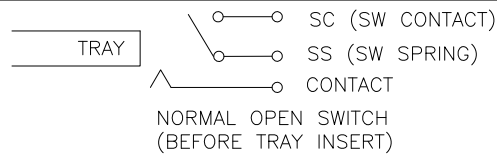

UNLESS OTHERWISE SPECIFIED TOLERANCES

DECIMALS:	ANGLES:
X :±0.5	X :±2°
X.X :±0.20	X.X :±1°
X.XX :±0.10	

东莞市讯普电子科技有限公司

TITLE	1.35H PIN PUSH T-Flash CARD CONN.(With Tray)			
DWN	ALLEN	PART NO.	TF-107	
CHKD	KEVIN	SCALE:1:1	UNIT: mm	
APVD	ERIC.W	SIZE: A3	SHEET:1OF 1	REV: A1

CUSTOMER COPY

REV.	ECN NO OR DESCRIPTION	REVISED	DATE
▽	PROPOSE ONLY	ALLEN	2015.12.04

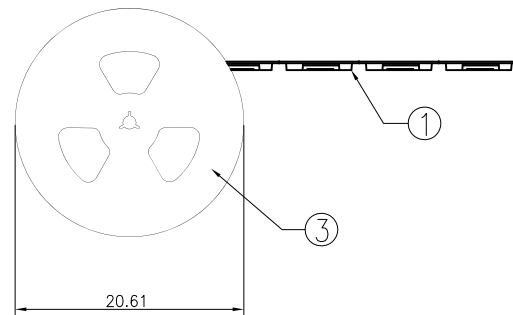
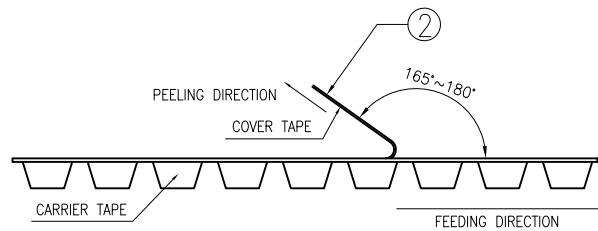
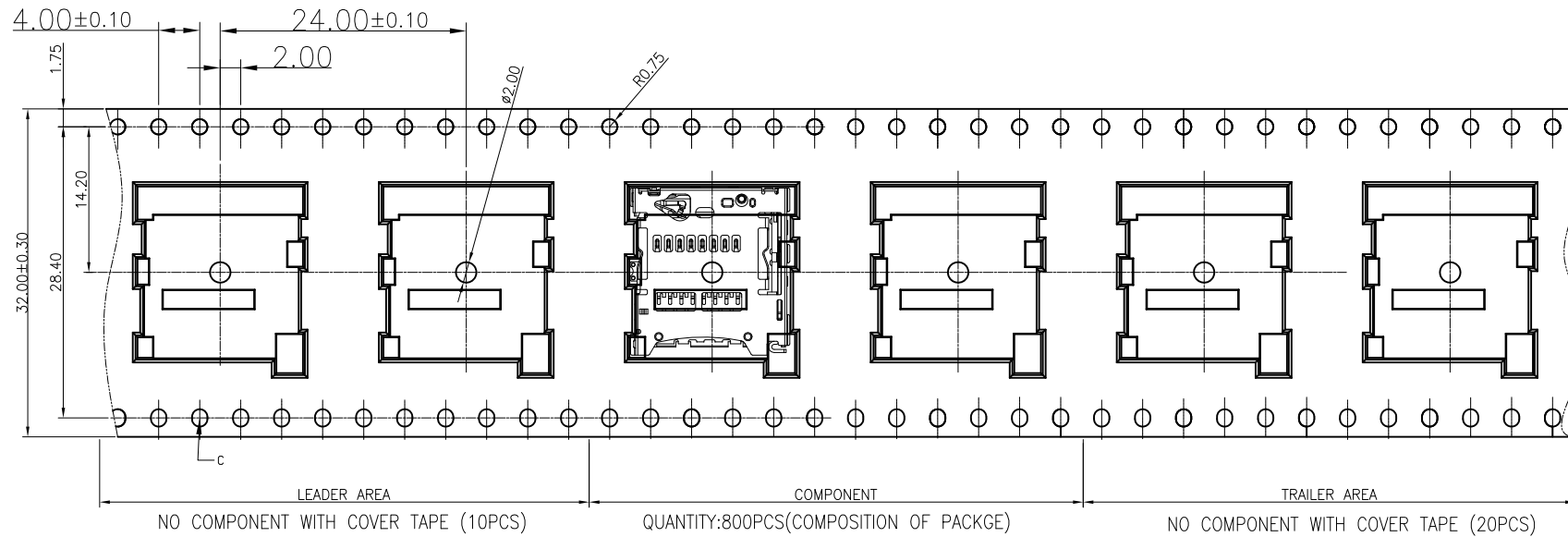

NOTES:

- 1, POCKET HOLE PITCH CLUMATIVE TOLERANCE  $\pm 0.40\text{mm}$
- 2, Packaging capacity:  
800pcs/REEL; 8REELI/CARTON ; TOTAL: 6400PCS/CARTON
- 3, Packaging Use Attention:  
NOT TWISTED OVER 90° WITHIN 1000mm.

3	REEL	PLOYSTYRENE
2	COVER TAPE	PLOYSTYRENE
1	CARRIER TAPE	THERMOPLASTIC
ITEM	P/N	MATERIAL

UNLESS OTHERWISE SPECIFIED TOLERANCES		东莞市讯普电子科技有限公司			
DECIMALS:	ANGLES:	TITLE	1.35H PIN PUSH T-Flash CARD CONN.(With Tray)		
X :±0.5	X :±2°	DWN	ALLEN	PART NO.	TF-107
X.X :±0.20	X.X :±1°	CHKD	KEVIN	SCALE:1:1	UNIT: mm
X.XX :±0.10		APVD	ERIC.W	SIZE: A3	SHEET:1OF 1
		REV: A1			
CUSTOMER COPY					

REV.	ECN NO OR DESCRIPTION	REVISED	DATE
1	PROPOSE ONLY	ALLEN	2015.12.04

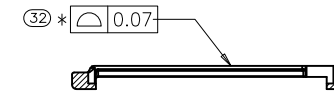
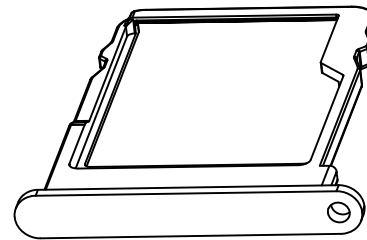
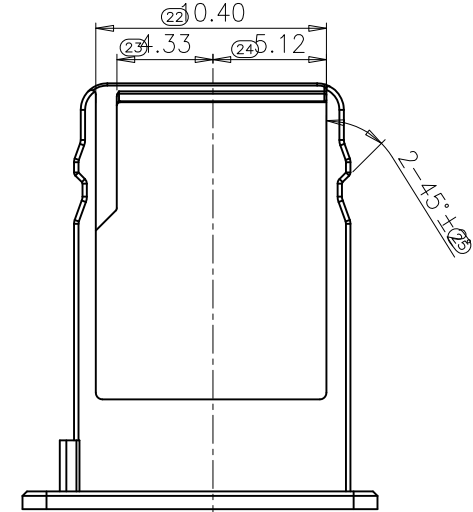
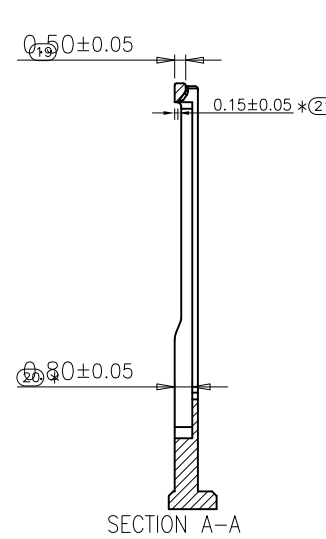
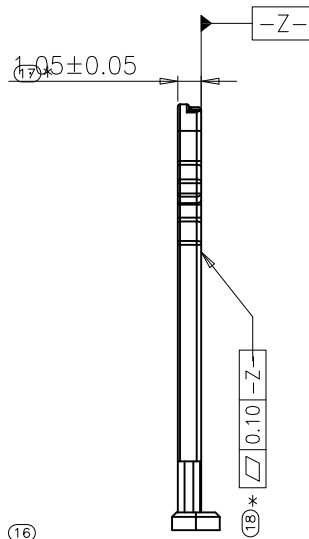
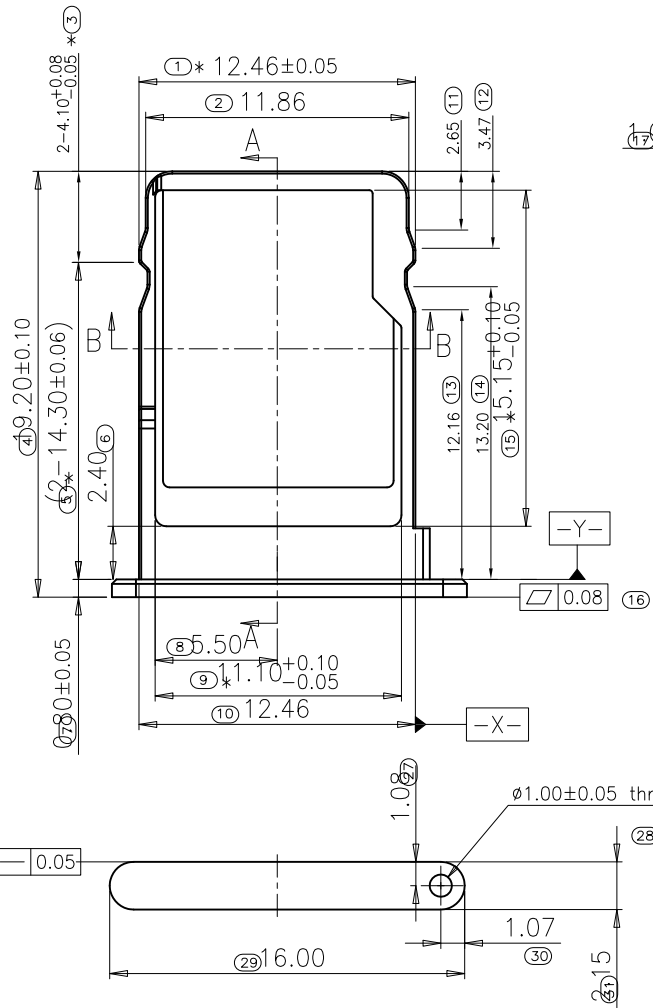

SECTION B-B

NOTES:

- 1.材料: 粉末冶金 17-4PH F.
- 2.外觀處理: 需參照ID工藝文件.  
產品表面不得有鋒利邊, 毛刺, 壓痕, 劃傷, 油污, 多料, 缺料, 扭曲變形, 裂痕等缺陷.
- 3.尺寸: 2D圖面未標注公差尺寸, 其公差參照公差表; 未標注尺寸, 參照3D圖槽, 其公差參照公差表;  
帶\*尺寸為重點尺寸, 要求每批次檢驗; 帶▽尺寸需管控CPK, 且CPK ≥ 1.33;  
未注工藝圓角, R ≤ 0.2mm; 未注同軸度0.1mm, 未注垂直度0.1mm;  
未注拔模角度為1度或按0.05mm減膠拔模; 未注同軸度0.1mm, 未注垂直度0.1mm;  
尺寸序號: 1~33.
- 4.產品需滿足(EU)WEEE和ROHS等認證要求; 在產品制程之原物料/  
零件必須符合EPI12環境管理物質規定.

UNLESS OTHERWISE SPECIFIED TOLERANCES		东莞市讯普电子科技有限公司			
DECIMALS:	ANGLES:	TITLE	1.35H PIN PUSH T-Flash CARD CONN.(With Tray)		
X :±0.5	X :±2°	DWN	ALLEN	PART NO.	TF-107
X.X :±0.20	X.X :±1°	CHKD	KEVIN	SCALE:1:1	UNIT: mm
X.XX :±0.10		APVD	ERIC.W	SIZE: A3	SHEET:1OF 1
		REV: A1			
CUSTOMER COPY					