

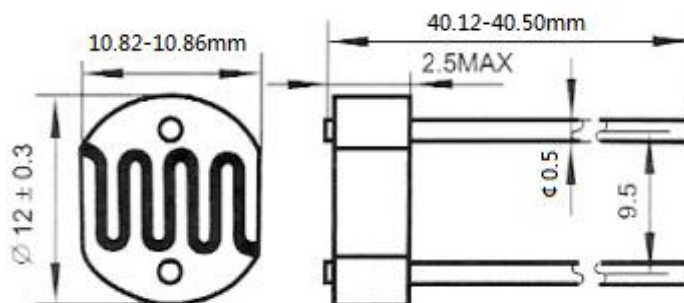

### FEATURES

- Miniature open frame package
- Epoxy coated
- Moisture resistant
- Spectral response similar to the human eye
- Applications include dusk-dawn lighting control

### LIGHT DEPENDENT RESISTOR



Dimensions in millimetres

### SPECIFICATION AND PERFORMANCE

Model	Vmax (VDC)	Pmax (mW)	Ambient temp(°C)	Spectral peak (nm)	Light Resistance at 10Lux (KΩ)	Dark Resistance (MΩ)	Gamma value at 100-10Lux	Response Time (ms)	
								Rise Time	Decay time
GL12528	250	250	-30~+70	540	8-20	2	0.8	20	30

### Measuring Conditions

#### 1. Light resistance:

Measured at 10 Lux with standard light A (2854K color temperature) and 2hr illumination at 400-600 lux prior to testing.

#### 2. Dark Resistance:

Measured 10 seconds after closed 10 lux.

#### 3. Gamma Characteristic:

Between 10 lux and 100 lux and given by

$$\gamma = \lg(R_{10}/R_{100})$$

R<sub>10</sub>、R<sub>100</sub> Cell resistance at 10 lux and 100 lux.

The error of  $\gamma$  is  $\pm 0.1$ .

#### 4. Pmax:

Max. power dissipation at ambient temperature of 25 °C.

#### 5. Vmax:

Max. voltage in darkness that may be applied to the cell continuously.

### Spectral Response

