

Features:

- Peak breakdown voltage
 - 250V: EL303X(P5)
 - 400V: EL304X(P5)
 - 600V: EL306X(P5)
 - 800V: EL308X(P5)
- High isolation voltage between input and output (Viso=5000 V rms)
- Zero voltage crossing
- Pb free and RoHS compliant.
- UL approved (No.E214129)
- VDE approved (No.132249)
- SEMKO approved
- NEMKO approved
- DEMKO approved
- FIMKO approved
- CSA approved
- CQC approved

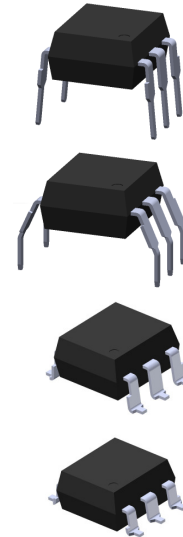

Description

The EL303X(P5), EL304X(P5), EL306X(P5) and EL308X(P5) series of devices each consist of a GaAs infrared emitting diode optically coupled to a monolithic silicon zero voltage crossing photo triac.

They are designed for use with a discrete power triac in the interface of logic systems to equipment powered from 110 to 380 VAC lines, such as solid-state relays, industrial controls, motors, solenoids and consumer appliances.

Applications

- Solenoid/valve controls
- Light controls
- Static power switch
- AC motor drivers
- E.M. contactors
- Temperature controls
- AC Motor starters

Schematic

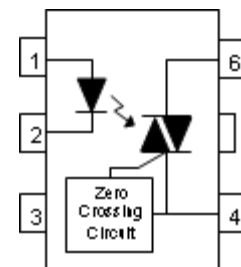

Pin Configuration

1. Anode
2. Cathode
3. No Connection
4. Terminal
5. Pin Cut
6. Terminal

Absolute Maximum Ratings ($T_a=25^\circ\text{C}$)

Parameter		Symbol	Rating	Unit
Input	Forward current	I_F	60	mA
	Reverse voltage	V_R	6	V
	Power dissipation Derating factor (above 85°C)	P_D	100	mW
	3.8		mW / $^\circ\text{C}$	
Output	Off-state Output Terminal Voltage	V_{DRM}	EL303X 250	V
			EL304X 400	
			EL306X 600	
			EL308X 800	
	Peak Repetitive Surge Current	I_{TSM}	1	A
	Power dissipation Derating factor (above 85°C)	P_D	300	mW
	7.6		mW / $^\circ\text{C}$	
Isolation voltage ^{*1}		V_{iso}	5000	V rms
Total power dissipation		P_D	330	mW
Operating temperature		T_{opr}	-55~+100	$^\circ\text{C}$
Storage temperature		T_{stg}	-55~+125	$^\circ\text{C}$
Soldering temperature ^{*2}		T_{sol}	260	$^\circ\text{C}$

Notes

*1 AC for 1 minute, R.H.= 40 ~ 60% R.H. In this test, pins 1, 2 & 3 are shorted together, and pins 4, 5 & 6 are shorted together.

*2 For 10 seconds.

Electrical Characteristics (T_a=25 °C unless specified otherwise)

Input

Parameter	Symbol	Min.	Typ.*	Max.	Unit	Condition
Forward voltage	V _F	-	-	1.5	V	I _F = 30mA
Reverse Leakage current	I _R	-	-	10	μA	V _R = 6V

Output

Parameter	Symbol	Min.	Typ.*	Max.	Unit	Condition
Peak Blocking Current	EL303X/304X	-	-	100	nA	V _{DRM} = Rated V _{DRM} I _F = 0mA
	EL306X/308X			500		
Peak On-state Voltage	V _{TM}	-	-	3	V	I _{TM} =100mA peak, I _F =Rated I _{FT}
Critical Rate of Rise of off-state Voltage	EL303X /304X /306X	dv/dt	1000	-	V/μs	V _{PEAK} =Rated V _{DRM} , I _F =0 (Fig. 10)
	EL308X		600	-		
Inhibit Voltage (MT1-MT2 voltage above which device will not trigger)	V _{INH}	-	-	20	V	I _F = Rated I _{FT}
Leakage in Inhibited State	I _{DRM2}	-	-	500	μA	I _F = Rated I _{FT} , V _{DRM} =Rated V _{DRM} , off state

Transfer Characteristics

Parameter	Symbol	Min.	Typ.*	Max.	Unit	Condition
LED Trigger Current	EL3031 EL3041 EL3061 EL3081	-	-	15	mA	Main terminal Voltage=3V
	EL3032 EL3042 EL3062 EL3082			10		
	EL3033 EL3043 EL3063 EL3083			5		
Holding Current	I _H	-	280	-	μA	

* Typical values at T_a = 25 °C

Typical Performance Curves

Figure 1. Forward Current vs Forward Voltage

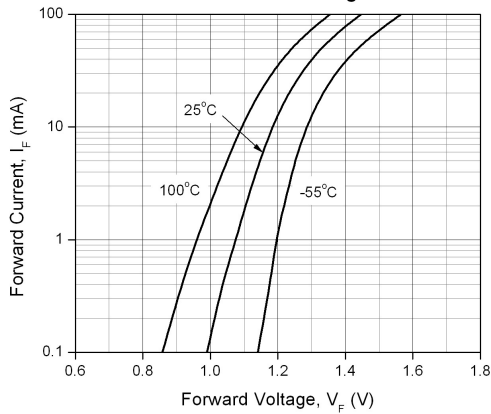

Figure 2. On-State Characteristics

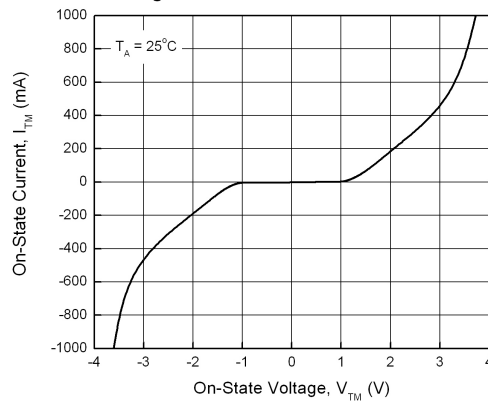

Figure 3. Holding Current vs. Ambient Temperature

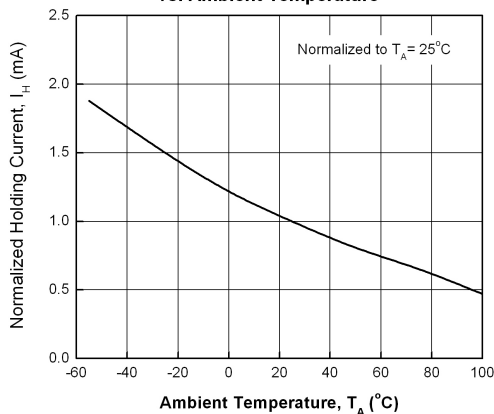

Figure 4. LED Current Required to Trigger vs. LED Pulse Width

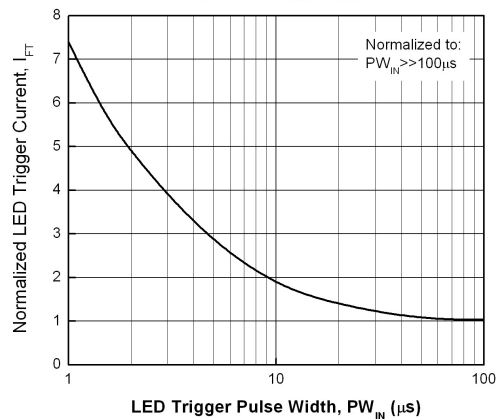

Figure 5. Leakage Current vs. Ambient Temperature

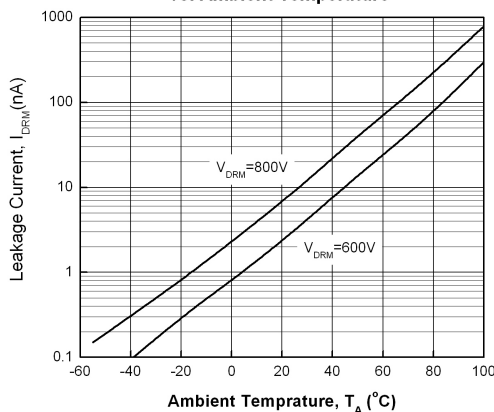

Figure 6. LED Trigger Current vs. Ambient Temperature

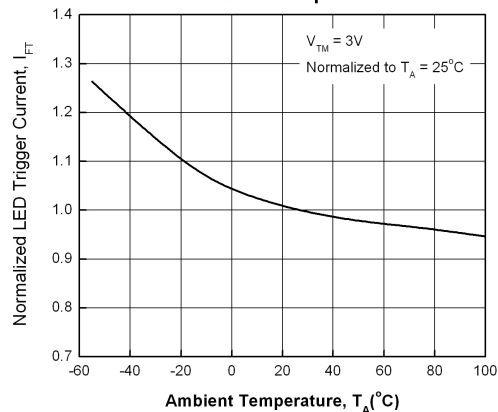

Figure 7. Off-State Output Terminal Voltage vs. Ambient Temperature

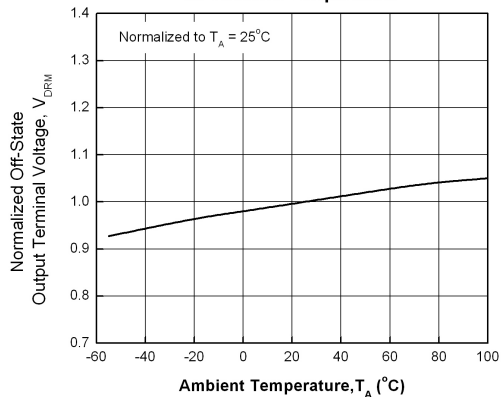

Figure 8. Leakage in Inhibit State vs. Ambient Temperature

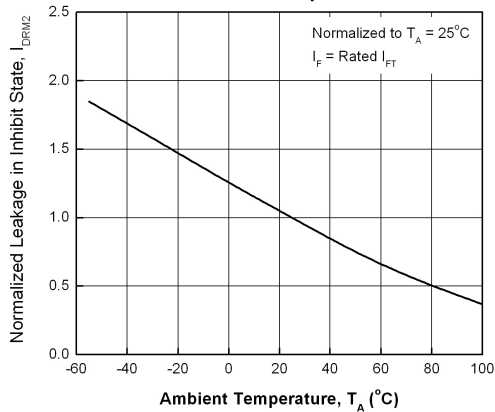

Figure 9. Inhibit Voltage vs. Ambient Temperature

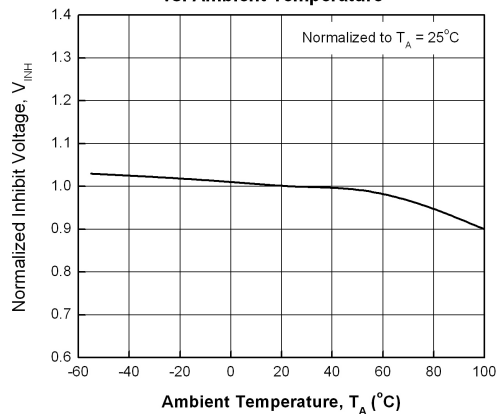
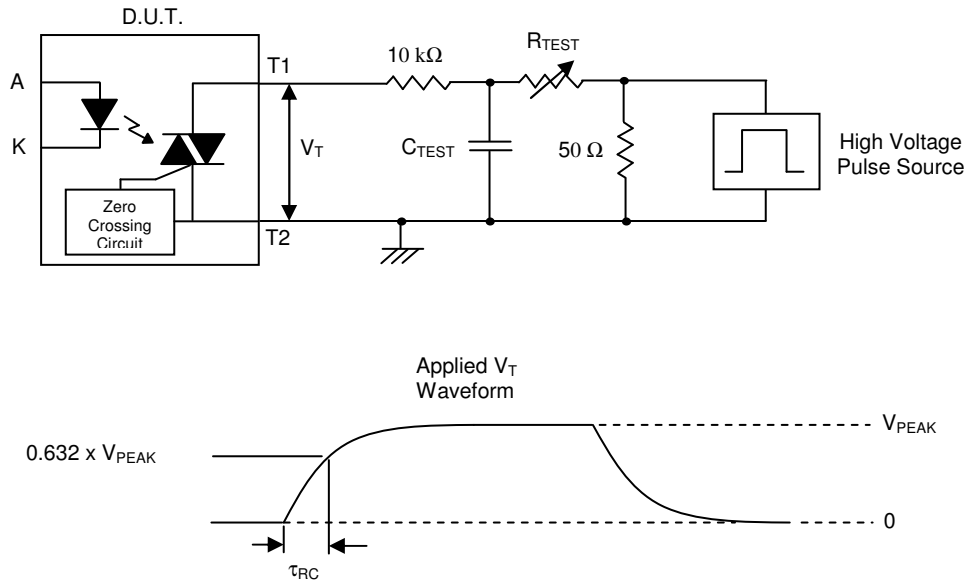

Figure 10. Static dv/dt Test Circuit & Waveform



Measurement Method

The high voltage pulse is set to the required V_{PEAK} value and applied to the D.U.T. output side through the RC circuit above. LED current is not applied. The waveform V_T is monitored using a x100 scope probe. By varying R_{TEST} , the dv/dt (slope) is increased, until the D.U.T. is observed to trigger (waveform collapses). The dv/dt is then decreased until the D.U.T. stops triggering. At this point, τ_{RC} is recorded and the dv/dt calculated.

$$dv/dt = \frac{0.632 \times V_{PEAK}}{\tau_{RC}}$$

For example, $V_{PEAK} = 600V$ for EL306X series. The dv/dt value is calculated as follows:

$$dv/dt = \frac{0.63 \times 600}{\tau_{RC}} = \frac{378}{\tau_{RC}}$$

Order Information

Part Number

EL303XY(Z)(P5)-V
or **EL304XY(Z)(P5)-V**
or **EL306XY(Z)(P5)-V**
or **EL308XY(Z)(P5)-V**

Note

X = Part No. (1, 2 or 3)

Y = Lead form option (S, S1, M or none)

Z = Tape and reel option (TA, TB or none).

P5 = 5 pins type

V = VDE safety approved (optional)

Option	Description	Packing quantity
None	Standard DIP-6	65 units per tube
M	Wide lead bend (0.4 inch spacing)	65 units per tube
S (TA)	Surface mount lead form + TA tape & reel option	1000 units per reel
S (TB)	Surface mount lead form + TB tape & reel option	1000 units per reel
S1 (TA)	Surface mount lead form (low profile) + TA tape & reel option	1000 units per reel
S1 (TB)	Surface mount lead form (low profile) + TB tape & reel option	1000 units per reel

Package Drawings

(Dimensions in mm)

Standard DIP Type

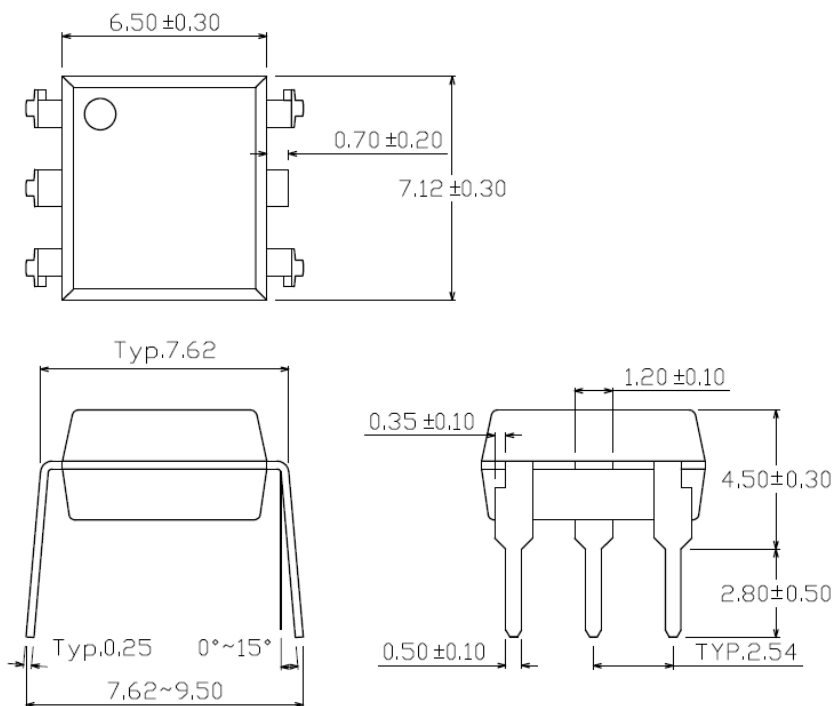

Option M Type

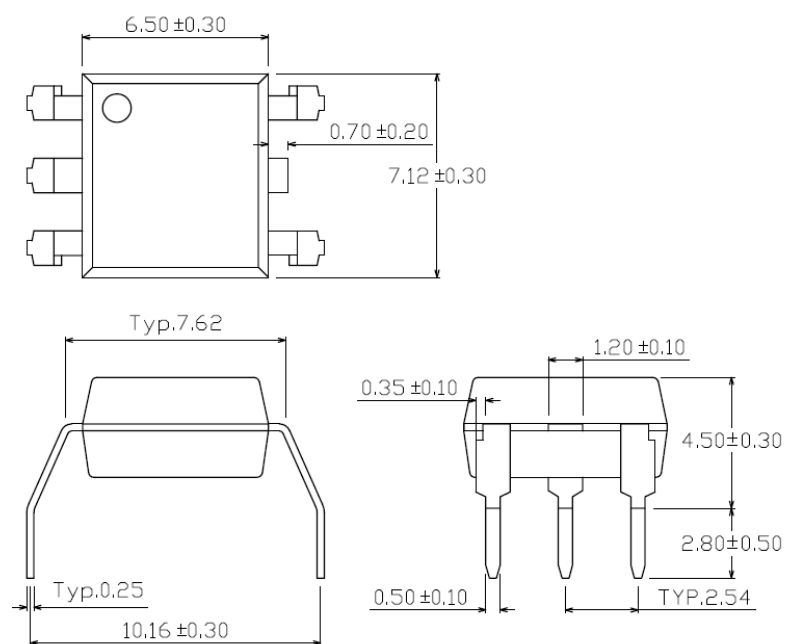

Option S Type

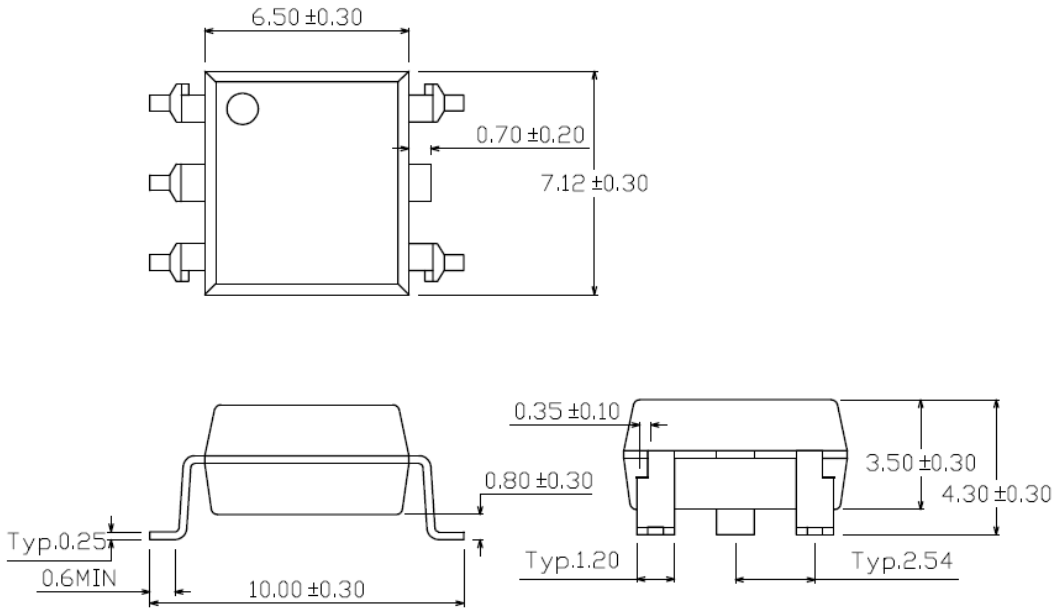

Option S1 Type

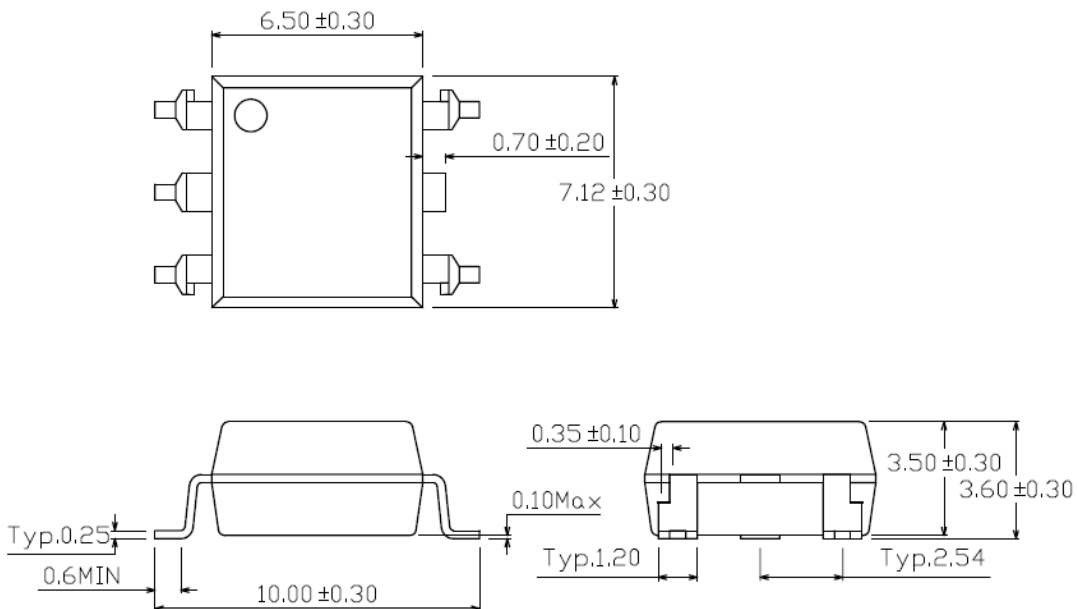

Recommended pad layout for surface mount leadform

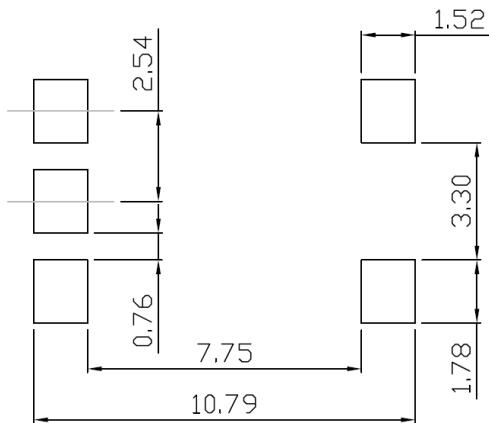

Device Marking

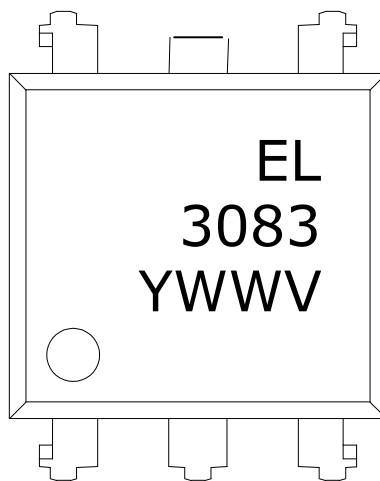

Notes

EL denotes Everlight
3083 denotes Device Number
Y denotes 1 digit Year code
WW denotes 2 digit Week code
V denotes VDE optional

Tape & Reel Packing Specifications

Option TA

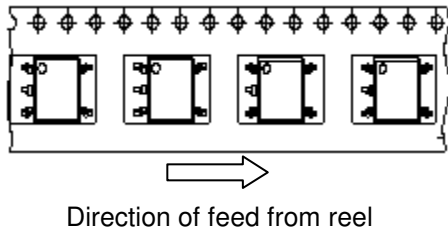

Option TB

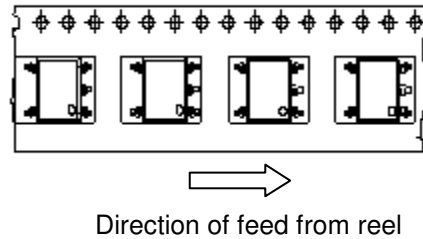

Tape dimensions

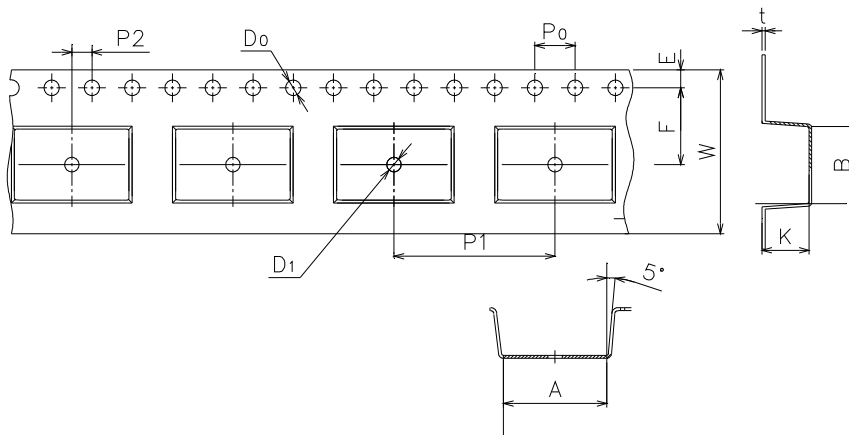

Dimension No.	A	B	Do	D1	E	F
Dimension (mm)	10.4±0.1	7.52±0.1	1.5+0.1/-0	1.5+0.1/-0	1.75±0.1	7.5±0.1

Dimension No.	Po	P1	P2	t	W	K
Dimension (mm)	4.0±0.15	1.6±0.1	2.0±0.1	0.35±0.03	16.0±0.2	4.5±0.1

Solder Reflow Temperature Profile

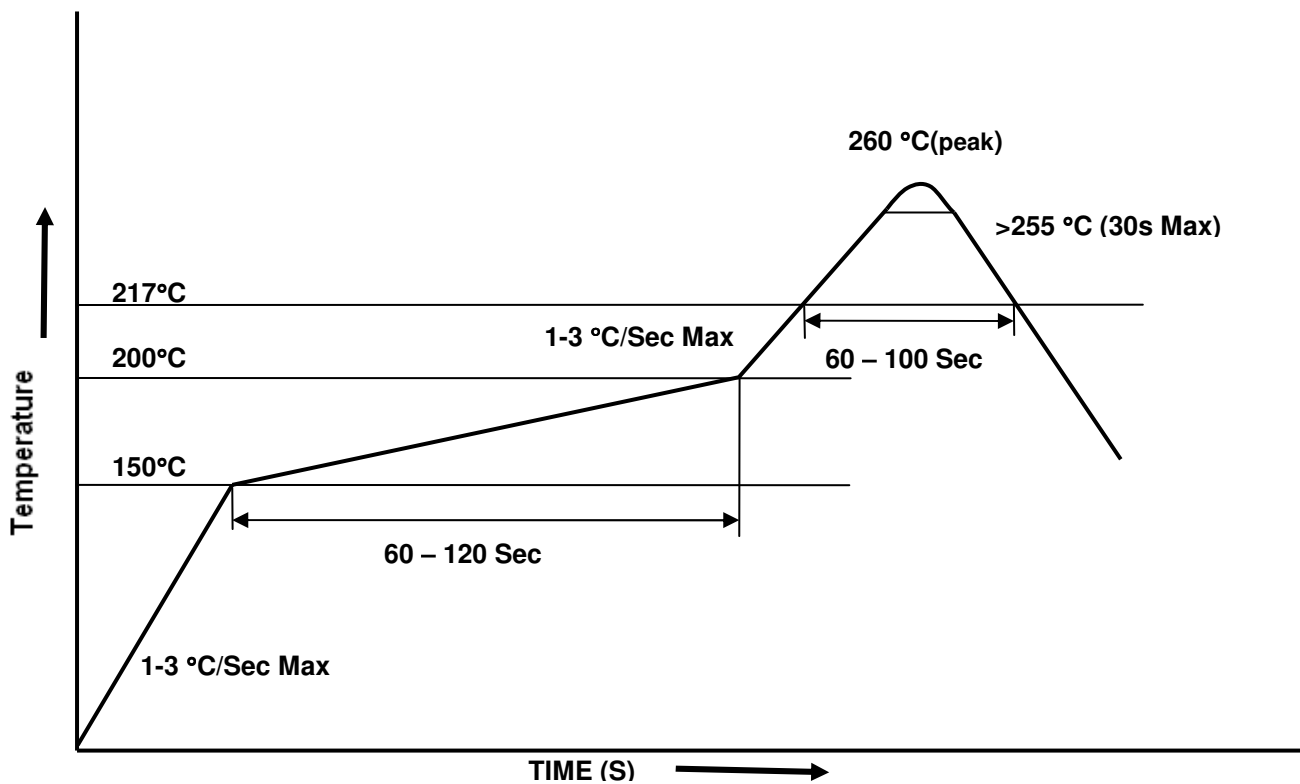

DISCLAIMER

1. Above specification may be changed without notice. EVERLIGHT will reserve authority on material change for above specification.
2. When using this product, please observe the absolute maximum ratings and the instructions for use outlined in these specification sheets. EVERLIGHT assumes no responsibility for any damage resulting from use of the product which does not comply with the absolute maximum ratings and the instructions included in these specification sheets.
3. These specification sheets include materials protected under copyright of EVERLIGHT. Reproduction in any form is prohibited without the specific consent of EVERLIGHT.