

## CRYSTAL-LESS SoC RF TRANSMITTER

### Features

- Crystal-less operation
  - Optional crystal oscillator input
- High-Speed 8051  $\mu$ C Core
  - Pipeline instruction architecture
  - 70% of instructions in 1 or 2 clocks
  - Up to 24 MIPs with 24 MHz clock
  - 4 kB RAM/8kB NVM
  - 128 bit EEPROM
  - 256 byte of internal data RAM
  - 12 kB ROM embedded functions
  - 8 byte low leakage RAM
- Extensive Digital Peripherals
  - 128 bit AES accelerator
  - 5/9 GPIO with wakeup functionality
  - LED driver
  - Data serializer
  - High-speed frequency counter
  - On-chip debugging: C2
  - Unique 4 byte serial number
  - Ultra low-power sleep timer
- Single Coin-Cell Battery Operation
  - Supply voltage: 1.8 to 3.6 V
  - Standby current < 10 nA
- High-performance RF transmitter
  - Frequency range: 27–960 MHz
  - +10 dBm output power, adjustable
  - Automatic antenna tuning
  - Symbol rate up to 100 kbps
  - FSK/OOK modulation
  - Manchester, NRZ, 4/5 encoder
- Analog Peripherals
  - LDO regulator with POR circuit
  - Battery voltage monitor
- Temperature range –40 to +85 °C
- Automotive quality option, AEC-Q100 (Pending final qualification testing)
- 10-pin MSOP/14-pin SOIC

### Applications

- Garage and gate door openers
- Remote keyless entry
- Home automation and security
- Wireless remote controls

### Description

The Si4010 is a fully integrated crystal-less CMOS SoC RF transmitter with an embedded CIP-51 8051 MCU. The device can operate over the –40 to 85 °C temperature range without requiring an external crystal reference source reducing board area and BOM cost. The device includes an 8 kB non volatile memory block for programming the user's application along with a 12 kB ROM of embedded support code for use in the user's application. The Si4010 includes Silicon Laboratories' 2-wire C2 Debug and Programming interface, which allows customers to download their code during the development stage into the on-board RAM for testing and debug prior to programming the NVM.

The Si4010 is designed for low power battery applications with standby currents of less than 10 nA to optimize battery life and features automatic wake on button press support to efficiently move from the standby to active mode state with minimal customer code support. Built in AES-128 hardware encryption along with a 128-bit EEPROM can be used to create robust data encryption of the transmitted packets. A unique 4-byte serial number is programmed into each device ensuring non-overlapping device identifiers.

The RF transmitter features a high efficiency PA capable of delivering output power up to +10 dBm and includes an automatic antenna tuning algorithm. This algorithm adjusts the antenna tuning at the start of each packet transmission for optimal output power minimizing the impact of antenna impedance changes due to the remote being held in a user hand. The devices supports FSK and OOK modulations and includes automatic output power shaping to reduce spectral spreading and ease regulatory compliance. The output frequency can be adjusted via software over the entire 27 to 960 MHz range. The output data rate is software adjustable up to a maximum rate of 100 kbps.

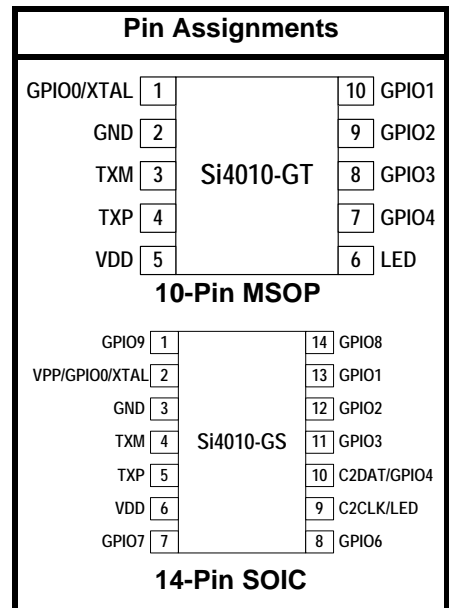
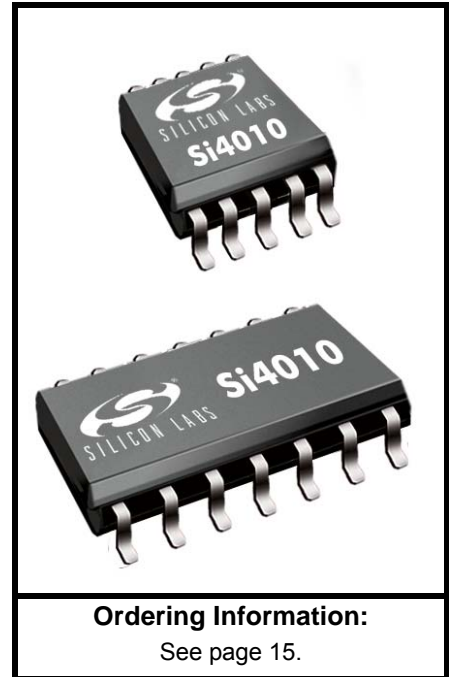

Patents pending

# Si4010-C2

## Functional Block Diagram

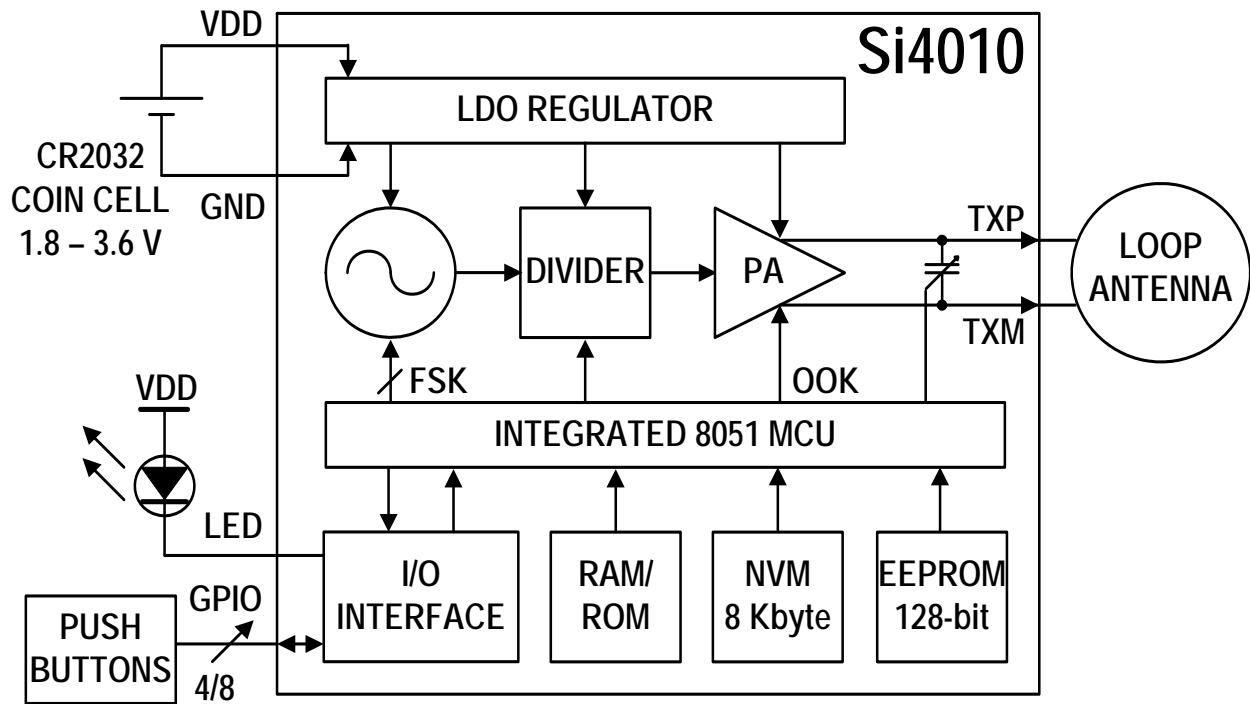

## TABLE OF CONTENTS

---

<b>1. System Overview</b> .....	<b>11</b>
<b>2. Test Circuit</b> .....	<b>13</b>
<b>3. Typical Application Schematic</b> .....	<b>14</b>
3.1. Si4010 Used in a 5-Button RKE System with LED Indicator .....	14
3.2. Si4010 with an External Crystal in a 4-Button RKE System with LED Indicator .....	14
<b>4. Ordering Information</b> .....	<b>15</b>
<b>5. Top Markings</b> .....	<b>16</b>
5.1. SOIC .....	16
5.2. MSOP .....	17
<b>6. Pin Definitions</b> .....	<b>18</b>
6.1. MSOP, Application .....	18
6.2. MSOP, Programming/Debug Mode .....	19
6.3. SOIC Package, Application .....	20
6.4. SOIC Package, Programming/debug Mode .....	21
<b>7. Package Specifications</b> .....	<b>22</b>
7.1. 10-Pin MSOP .....	22
7.2. 14-pin SOIC Package .....	23
<b>8. PCB Land Pattern 10-Pin MSOP</b> .....	<b>24</b>
<b>9. PCB Land Pattern 14-pin SOIC Package</b> .....	<b>26</b>
<b>10. Electrical Characteristics</b> .....	<b>28</b>
<b>11. System Description</b> .....	<b>33</b>
11.1. Overview .....	33
11.2. Setting Basic Si4010 Transmit Parameters .....	35
11.3. Applications Programming Interface (API) Commands .....	35
<b>12. Power Amplifier</b> .....	<b>36</b>
12.1. Register Description .....	38
<b>13. Output Data Serializer (ODS)</b> .....	<b>40</b>
13.1. Description .....	40
13.2. Timing .....	40
13.3. Register Description .....	41
<b>14. LC Oscillator (LCOSC)</b> .....	<b>46</b>
14.1. Register Description .....	46
<b>15. Low Power Oscillator and System Clock Generator</b> .....	<b>47</b>
15.1. Register Description .....	47
<b>16. Crystal Oscillator (XO)</b> .....	<b>49</b>
16.1. Register Description .....	49
<b>17. Frequency Counter</b> .....	<b>50</b>
17.1. Register Description .....	52
<b>18. Sleep Timer</b> .....	<b>54</b>
<b>19. Bandgap and LDO</b> .....	<b>54</b>
<b>20. Low Leakage HVRAM</b> .....	<b>54</b>
<b>21. Temperature Sensor</b> .....	<b>54</b>
<b>22. CIP-51 Microcontroller</b> .....	<b>55</b>

# Si4010-C2

---

- 22.1. Instruction Set56
  - 22.1.1. Instruction and CPU Timing56
- 22.2. CIP-51 Register Descriptions61

## **23. Memory Organization65**

- 23.1. Program Memory66
- 23.2. Internal Data Memory66
- 23.3. External Data Memory66
- 23.4. General Purpose Registers66
- 23.5. Bit Addressable Locations67
- 23.6. Stack67
- 23.7. Special Function Registers (SFR)67
- 23.8. Registers Mapped to XDATA Address Space (XREG)67
- 23.9. NVM (OTP) Memory67
- 23.10. MTP (EEPROM) Memory68

## **24. System Boot and NVM Programming69**

- 24.1. Startup Overview69
- 24.2. Reset70
- 24.3. Chip Program Levels70
- 24.4. NVM Organization71
- 24.5. Device Boot Process72
- 24.6. Error Handling During Boot73
- 24.7. CODE/XDATA RAM Address Map73
- 24.8. Boot Status Variables76
- 24.9. Boot Routine Destination Address Space79
- 24.10. NVM Programming80
- 24.11. Retest and Retest Configuration81
- 24.12. Boot and Retest Protection NVM Control Byte83
- 24.13. Chip Protection Control Register84

## **25. On-Chip Registers85**

- 25.1. Special Function Registers85
- 25.2. XREG Registers88

## **26. Interrupts91**

- 26.1. MCU Interrupt Sources and Vectors92
- 26.2. Interrupt Priorities92
- 26.3. Interrupt Latency92
- 26.4. Interrupt Register Descriptions93
- 26.5. External Interrupts99

## **27. Power Management Modes101**

- 27.1. Idle Mode101
- 27.2. Stop Mode101

## **28. AES Hardware Accelerator103**

- 28.1. AES SFR Registers103

## **29. Reset Sources106**

- 29.1. Device Boot Outline106
- 29.2. External Reset106

29.3. Software Reset	107
<b>30. Port Input/Output</b>	<b>108</b>
30.1. GPIO Pin Special Roles	111
30.2. Pullup Roff Option	112
30.3. Matrix Mode Option	112
30.4. Pullup Roff and Matrix Mode Option Control	114
30.5. Special GPIO Modes Control	115
30.6. LED Driver on GPIO[5]	117
<b>31. Clock Output Generation</b>	<b>123</b>
31.1. Register Description	124
<b>32. Control and System Setting Registers</b>	<b>126</b>
<b>33. Real Time Clock Timer</b>	<b>128</b>
33.1. RTC Interrupt Flag Time Uniformity	129
33.2. Register Description	129
<b>34. Timers 2 and 3</b>	<b>131</b>
34.1. Interrupt Flag Generation	132
34.2. 16-bit Timer with Auto Reload (Wide Mode)	133
34.3. 16-bit Capture Mode (Wide Mode)	133
34.4. 8-Bit Timer/Timer Mode (Split Mode)	134
34.5. 8-Bit Capture/Capture Mode (Split Mode)	135
34.6. 8-Bit Timer/Capture Mode (Split Mode)	136
<b>35. C2 Interface</b>	<b>148</b>
35.1. C2 Pin Sharing	148
<b>36. IDE Development Environment and Debugging Chain</b>	<b>151</b>
36.1. Functionality Limitations While Using IDE Development Environment	151
36.2. Chip Shutdown Limitation	152
36.3. LED Driver Usage while Using IDE Debugging Chain	152
<b>37. Additional Reference Resources</b>	<b>154</b>
<b>Document Change List</b>	<b>155</b>
<b>Contact Information</b>	<b>156</b>

## LIST OF FIGURES

---

Figure 1.1. Si4010 Block Diagram .....	12
Figure 2.1. Test Block Diagram with 10-Pin MSOP .....	13
Figure 3.1. Si4010 Used in a 5-button RKE System with LED Indicator .....	14
Figure 3.2. Si4010 with an External Crystal in a 4-button RKE System with LED Indicator .....	14
Figure 1. Si4010 Top Marking .....	16
Figure 2. Si4010 Top Marking .....	17
Figure 7.1. 10-Pin MSOP Package .....	22
Figure 7.2. 14-Pin SOIC Package .....	23
Figure 8.1. 10-Pin MSOP Recommended PCB Land Pattern .....	24
Figure 9.1. 14-Pin SOIC Recommended PCB Land Pattern .....	26
Figure 11.1. Functional Block Diagram .....	33
Figure 12.1. Simplified PA Block Diagram .....	36
Figure 13.1. OOK Timing Example .....	40
Figure 13.2. FSK Timing Example .....	40
Figure 17.1. Frequency Counter Block Diagram .....	50
Figure 22.1. CIP-51 Block Diagram .....	55
Figure 23.1. Address Space Map after the Boot .....	65
Figure 24.1. NVM Address Map .....	72
Figure 24.2. CODE/XDATA RAM Address Map .....	75
Figure 24.3. Boot Routine Destination CPU Address Space for Copy from NVM .....	79
Figure 30.1. Device Package and Port Assignments .....	108
Figure 30.2. GPIO[3:1] Functional Diagram .....	110
Figure 30.3. Other GPIO Functional Diagram .....	110
Figure 30.4. Push Button Organization in Matrix Mode .....	113
Figure 30.5. GPIO[5] LED Driver Block Diagram .....	117
Figure 31.1. Output Clock Generator Block Diagram .....	123
Figure 33.1. RTC Timer Block Diagram .....	128
Figure 34.1. Timer Interrupt Generation .....	132
Figure 34.2. Timer 16-bit Mode Block Diagram (Wide Mode) .....	133
Figure 34.3. Capture 16-bit Mode Block Diagram (Wide Mode) .....	134
Figure 34.4. Two 8-bit Timers in Timer/Timer Configuration (Split Mode) .....	135
Figure 34.5. Two 8-bit Timers in Capture/Capture Configuration (Split Mode) .....	136
Figure 34.6. Two 8-bit Timers in Timer/Capture Configuration (Split Mode) .....	137
Figure 34.7. Two 8-bit Timers in Capture/Timer Configuration (Split Mode) .....	138
Figure 35.1. 10-pin C2 USB Debugging Adapter Connection to Device .....	148
Figure 35.2. 14-Pin C2 ToolStick Connection to Device .....	150

---

**LIST OF TABLES**

---

Table 4.1. Product Selection Guide .....	15
Table 1. Top Marking Explanation .....	16
Table 2. Top Marking Explanation .....	17
Table 7.1. Package Dimensions .....	22
Table 7.2. Package Dimensions .....	23
Table 8.1. 10-Pin MSOP Dimensions .....	25
Table 9.1. PCB Land Pattern Dimensions .....	27
Table 10.1. Recommended Operating Conditions .....	28
Table 10.2. Absolute Maximum Ratings <sup>1,2</sup> .....	28
Table 10.3. DC Characteristics .....	29
Table 10.4. Si4010 RF Transmitter Characteristics .....	30
Table 10.5. Low Battery Detector Characteristics .....	31
Table 10.6. Optional Crystal Oscillator Characteristics .....	31
Table 10.7. EEPROM Characteristics .....	32
Table 10.8. Low Power Oscillator Characteristics .....	32
Table 10.9. Sleep Timer Characteristics .....	32
Table 22.1. CIP-51 Instruction Set Summary .....	57
Table 24.1. Boot XDATA Status Variables .....	76
Table 24.2. Run Chip Retest Protection Flags: NVM Programmer .....	81
Table 25.1. Special Function Register (SFR) Memory Map .....	85
Table 25.2. Special Function Registers .....	86
Table 25.3. XREG Register Memory Map in External Memory .....	89
Table 25.4. XREG Registers .....	90
Table 26.1. Interrupt Summary .....	93
Table 30.1. 10-Pin Mode .....	109
Table 30.2. 14-Pin Mode .....	109
Table 30.3. GPIO Special Roles .....	111
Table 30.4. GPIO Special Roles Control and Order .....	116

## LIST OF XREG REGISTERS

---

XREG Definition 12.2. wPA_CAP .....	38
XREG Definition 12.3. bPA_TRIM .....	39
XREG Definition 15.1. bLPOSC_TRIM .....	47
XREG Definition 16.1. bXO_CTRL .....	49
XREG Definition 17.3. IFC_COUNT .....	53
XREG Definition 23.1. abMTP_RDATA[16] .....	68



## LIST OF SFR REGISTERS

---

SFR Definition 12.1. PA_LVL .....	38
SFR Definition 13.1. ODS_CTRL .....	41
SFR Definition 13.2. ODS_TIMING .....	42
SFR Definition 13.3. ODS_DATA .....	43
SFR Definition 13.4. ODS_RATEL .....	43
SFR Definition 13.5. ODS_RATEH .....	44
SFR Definition 13.6. ODS_WARM1 .....	44
SFR Definition 13.7. ODS_WARM2 .....	45
SFR Definition 14.1. LC_FSK .....	46
SFR Definition 15.2. SYSGEN .....	48
SFR Definition 17.1. FC_CTRL .....	52
SFR Definition 17.2. FC_INTERVAL .....	53
SFR Definition 22.1. DPL .....	61
SFR Definition 22.2. DPH .....	61
SFR Definition 22.3. SP .....	62
SFR Definition 22.4. ACC .....	62
SFR Definition 22.5. B .....	63
SFR Definition 22.6. PSW .....	64
SFR Definition 24.2. BOOT_FLAGS .....	78
NVM Byte Definition 24.3. PROT3_CTRL .....	83
SFR Definition 24.4. PROT0_CTRL .....	84
SFR Definition 26.1. IE .....	94
SFR Definition 26.2. IP .....	95
SFR Definition 26.3. EIE1 .....	96
SFR Definition 26.4. EIP1 .....	97
SFR Definition 26.5. INT_FLAGS .....	98
SFR Definition 26.6. PORT_INTCFG .....	100
SFR Definition 27.1. PCON .....	102
SFR Definition 28.1. GFM_DATA .....	104
SFR Definition 28.2. GFM_CONST .....	104
SFR Definition 28.3. SBOX_DATA .....	105
SFR Definition 28.4. SYS_SET .....	105
SFR Definition 30.1. P0 .....	118
SFR Definition 30.2. P0CON .....	119
SFR Definition 30.3. P1 .....	119
SFR Definition 30.4. P1CON .....	120
SFR Definition 30.5. P2 .....	120
SFR Definition 30.6. PORT_CTRL .....	121
SFR Definition 30.7. PORT_SET .....	122
SFR Definition 31.1. CLKOUT_SET .....	124
SFR Definition 32.1. GPR_CTRL .....	126
SFR Definition 32.2. GPR_DATA .....	126
SFR Definition 32.3. RBIT_DATA .....	127

# Si4010-C2

---

SFR Definition 33.1. RTC\_CTRL 130  
SFR Definition 34.1. TMR\_CLKSEL 139  
SFR Definition 34.2. TMR2CTRL 140  
SFR Definition 34.3. TMR2RL 142  
SFR Definition 34.4. TMR2RH 142  
SFR Definition 34.5. TMR2L 143  
SFR Definition 34.6. TMR2H 143  
SFR Definition 34.7. TMR3CTRL 144  
SFR Definition 34.8. TMR3RL 146  
SFR Definition 34.9. TMR3RH 146  
SFR Definition 34.10. TMR3L 147  
SFR Definition 34.11. TMR3H 147

---

## 1. System Overview

The Si4010 is a fully integrated crystal-less CMOS SoC RF transmitter with an embedded CIP-51 8051 MCU designed for the sub 1 GHz ISM frequency bands. This chip is optimized for battery powered applications with operating voltages from 1.8 to 3.6 V and ultra-low current consumption with a standby current of less than 10 nA. The high power amplifier can supply up to +10 dBm output power with 19.5 dB of programmable range. Moreover, the SoC transmitter includes a patented antenna tuning circuit that automatically fine tunes the resonance frequency and impedance matching between the PA output and the connected antenna for optimum transmit efficiency and low harmonic content. FSK and OOK modulation is supported with symbol rates up to 100 kbps. Like all wireless devices, users are responsible for complying with applicable local regulatory requirements for radio transmissions.

The embedded CIP-51 8051 MCU provides the core functionality of the Si4010. User software has complete control of all peripherals, and may individually shut down any or all peripherals for power savings. A space of 8 kB of on-chip one-time programmable NVM memory is available to store the user program and can also store unique transmit IDs. In case of power outages due to battery removal, 128 bits of EEPROM is available for counter or other operations providing non-volatile storage capability. A library of useful software functions such as AES encryption, a patented 32-bit counter providing 1 M cycles of read/write endurance, and many other functions are included in the 12 kB of ROM to reduce user design time and code space. General purpose input/output pins with push button wake-on touch capability, a programmable system clock, and ultra low power timers are also available to further reduce current consumption.

The Si4010 includes Silicon Laboratories' 2-wire C2 Debug and Programming interface. This debug logic supports memory inspection, viewing and modification of special function registers (SFR), setting break points, single stepping, and run and halt commands. All analog and digital peripherals are fully functional while debugging using C2. The two C2 interface pins can be shared with user functions, allowing in-system debugging without occupying package pins.

The device leverages Silicon Labs' patented and proven crystal-less oscillator technology and offers better than  $\pm 150$  ppm carrier frequency stability over the temperature range of 0 to + 70 °C and  $\pm 250$  ppm carrier frequency stability over the industrial range of -40 to + 85 °C without the use of an external crystal or frequency reference. The internal MCU automatically calibrates the on-chip voltage controlled oscillator (LCOSC) which forms the output carrier frequency for process and temperature variations. An external 1-pin crystal oscillator option is available for applications requiring tighter frequency tolerances.

Digital integration reduces the amount of required external components compared to traditional offerings, resulting in a solution that only requires a printed circuit board (PCB) implementation area of approximately 25 by 50 mm (including battery, switches, and 25 mm<sup>2</sup> antenna). The high integration of the Si4010 improves the system manufacturing reliability and quality and minimizes costs. This chip offers industry leading RF performance, high integration, flexibility, low BOM, small board area, and ease of design. No production alignment is necessary as all RF functions are integrated into the device.

# Si4010-C2

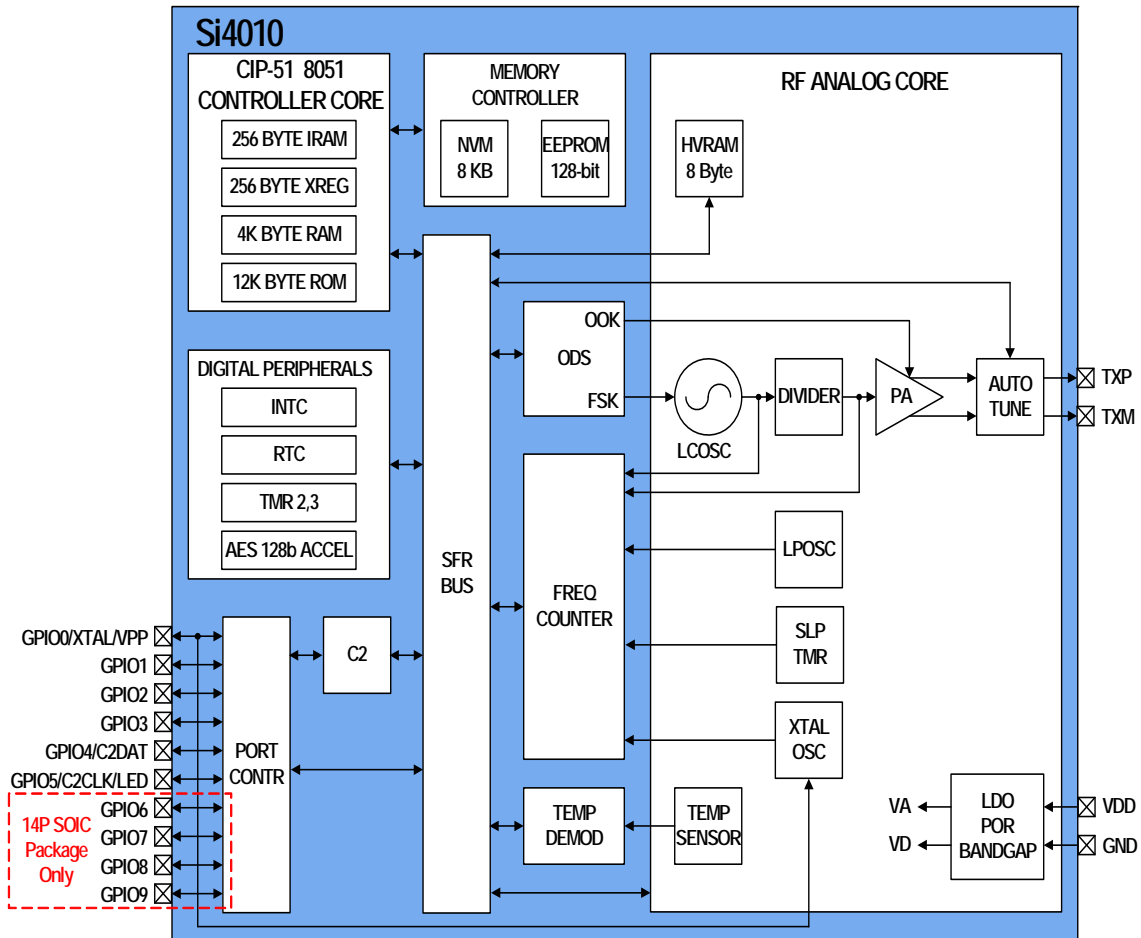

Figure 1.1. Si4010 Block Diagram

2. Test Circuit

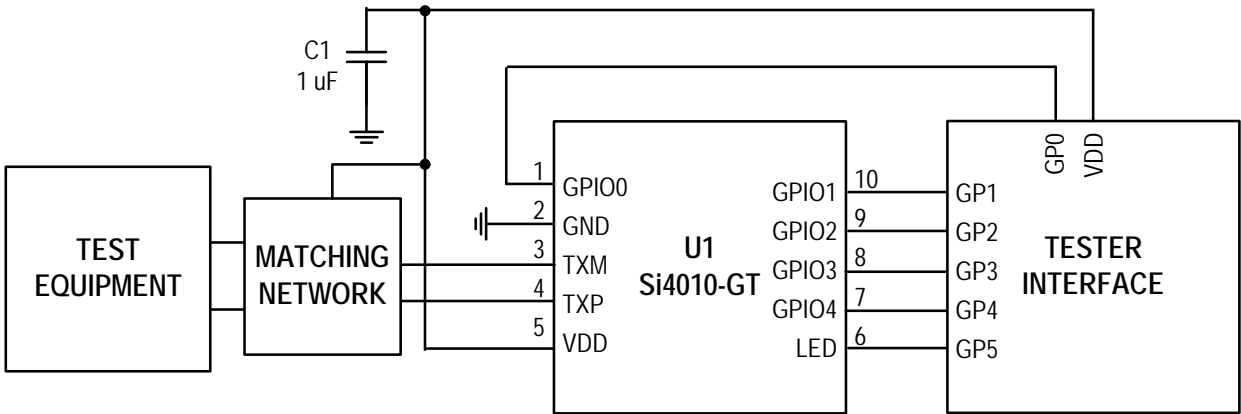

Figure 2.1. Test Block Diagram with 10-Pin MSOP

# Si4010-C2

## 3. Typical Application Schematic

### 3.1. Si4010 Used in a 5-Button RKE System with LED Indicator

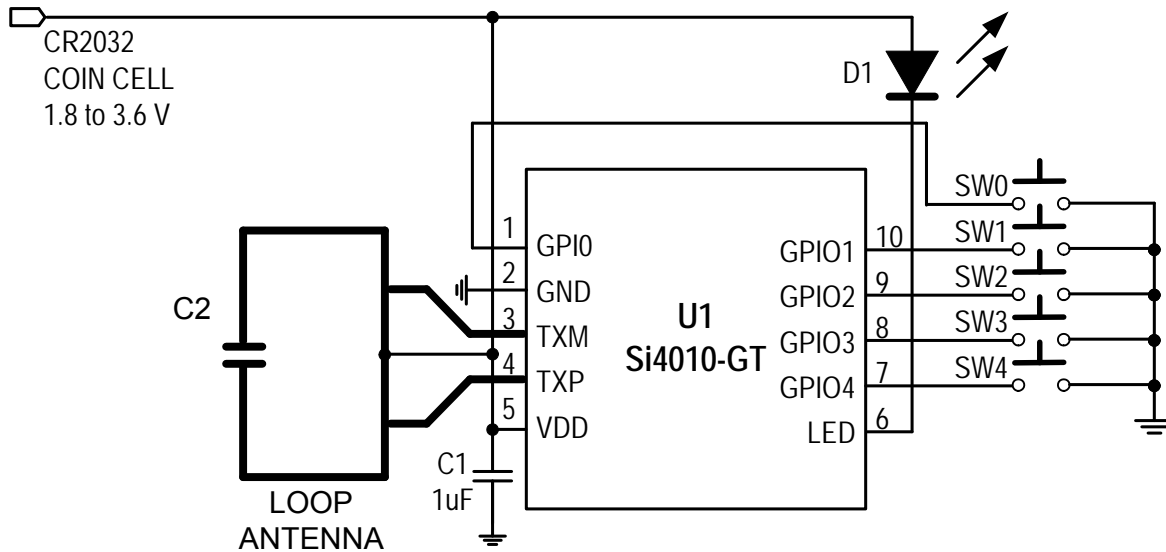

Figure 3.1. Si4010 Used in a 5-button RKE System with LED Indicator

### 3.2. Si4010 with an External Crystal in a 4-Button RKE System with LED Indicator

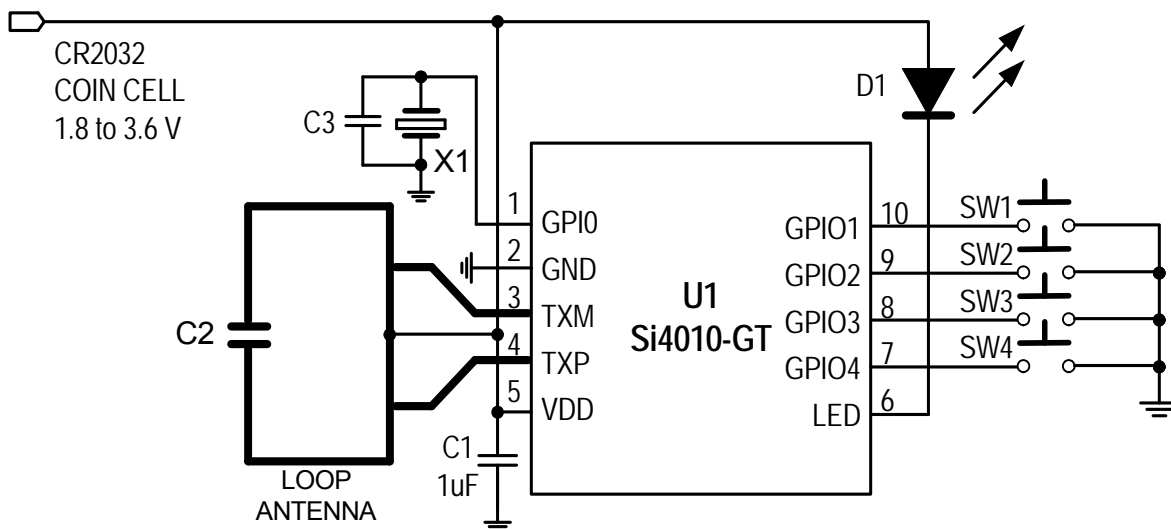

Figure 3.2. Si4010 with an External Crystal in a 4-button RKE System with LED Indicator

## 4. Ordering Information

Table 4.1. Product Selection Guide

Ordering Part Number <sup>1</sup>	MIPS (Peak)	NVM (OTP) Memory (Bytes)	RAM (Bytes)	Embedded ROM Functions	Internal Data RAM (Bytes)	HVRAM (Bytes)	EEPROM (Bits)	128-Bit AES Accelerator	GPIO with Wakeup <sup>2</sup>	LED Driver	Sleep Timer	+10 dBm RF Transmitter	LDO with POR Circuit	Low Battery Detector	Automotive Qualified <sup>3</sup>	Lead-free (RoHS Compliant)	Package
Si4010-C2-GT	24	8k	4k	Y	256	8	128	Y	5	1	Y	Y	Y	Y	—	Y	MSOP-10
Si4010-C2-GS	24	8k	4k	Y	256	8	128	Y	9	1	Y	Y	Y	Y	—	Y	SOIC-14
Si4010-C2-AT	24	8k	4k	Y	256	8	128	Y	5	1	Y	Y	Y	Y	Y	Y	MSOP-10
Si4010-C2-AS	24	8k	4k	Y	256	8	128	Y	9	1	Y	Y	Y	Y	Y	Y	SOIC-14

**Notes:**

1. Add an "(R)" at the end of the device part number to denote tape and reel option.
2. Assumes LED driver is used and no external crystal.
3. AEC Q100 qualification is pending.

# Si4010-C2

## 5. Top Markings

### 5.1. SOIC

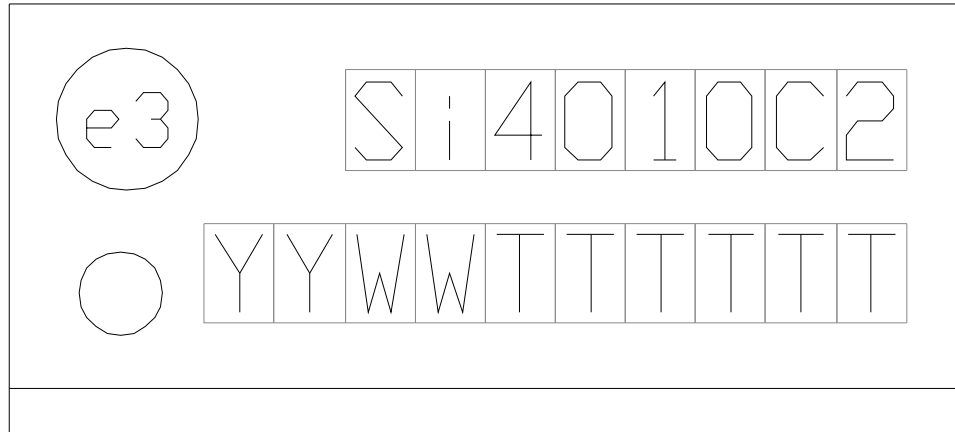

**Figure 1. Si4010 Top Marking**

**Table 1. Top Marking Explanation**

Line	Characters	Description
Line 1	Circle = 1.1 mm Diameter Left-Justified	"e3" Pb-Free Symbol
	Customer Part Number	Si4010C2
Line 2	YY = Year WW = Work Week	Assigned by the Assembly House. Corresponds to the year and work week of the assembly date.
	TTTTTT = Trace Code	Manufacturing code characters from the Markings section of the Assembly Purchase Order form.



## 5.2. MSOP

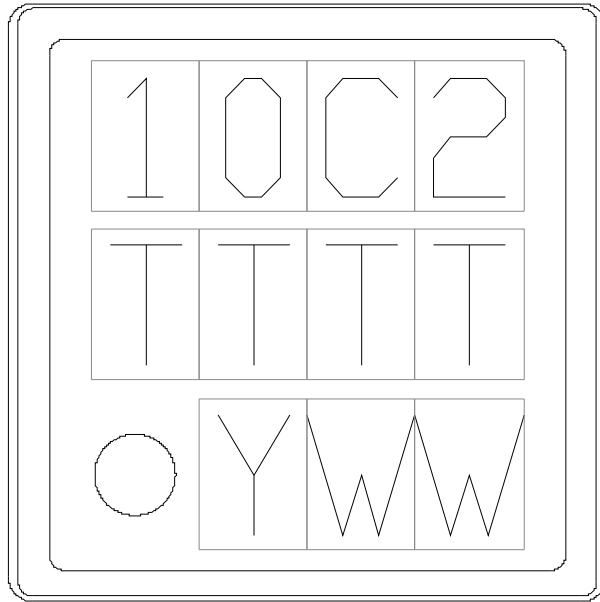

**Figure 2. Si4010 Top Marking**

**Table 2. Top Marking Explanation**

Line	Characters	Description
Line 1	Device Part Number	10C2
Line 2	TTTT = Trace Code	Line 2 from the "Markings" section of the Assembly Purchase Order form.
Line 3	YWW = Date Code	Date Code assigned by the assembly house. Y = Last Digit of Current Year (Ex: 2008 = 8) WW = Work Week of Mold Date.

## 6. Pin Definitions

### 6.1. MSOP, Application

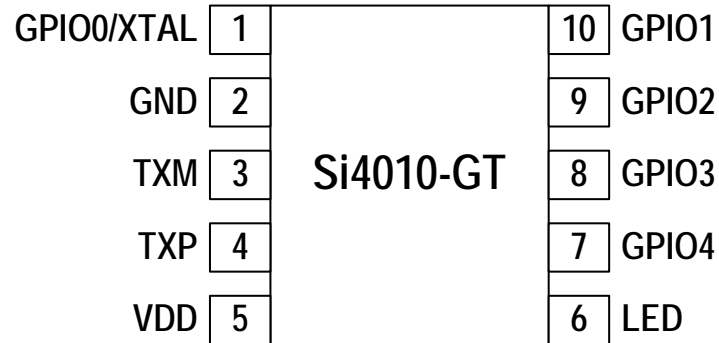

Pin Number(s)	Name	Description
1	GPIO0/XTAL	General purpose input pin. Can be configured as an input pin for a crystal.
2	GND	Ground. Connect to ground plane on PCB.
3, 4	TXM, TXP	Transmitter differential outputs.
5	VDD	Power.
6	LED	Dedicated LED driver.
7, 8, 9, 10	GPIO[4:1]	General purpose input/output pins.

# Si4010-C2

## 6.2. MSOP, Programming/Debug Mode

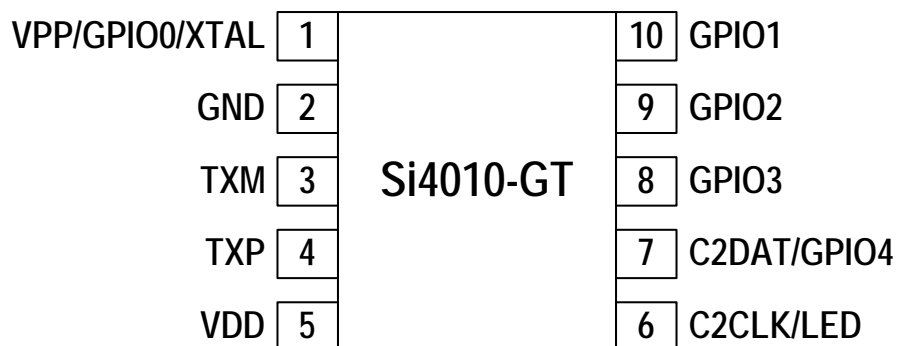

Pin Number(s)	Name	Description
1	VPP	+6.5 V required for NVM (OTP) Memory programming.
2	GND	Ground. Connect to ground plane on PCB.
3	TXM	Transmitter differential output.
4	TXP	Transmitter differential output.
5	VDD	Power.
6	C2CLK	C2 clock interface.
7	C2DAT	C2 data input/output pin.
8, 9, 10	GPIO[3:1]	General purpose input/output pins.

## 6.3. SOIC Package, Application

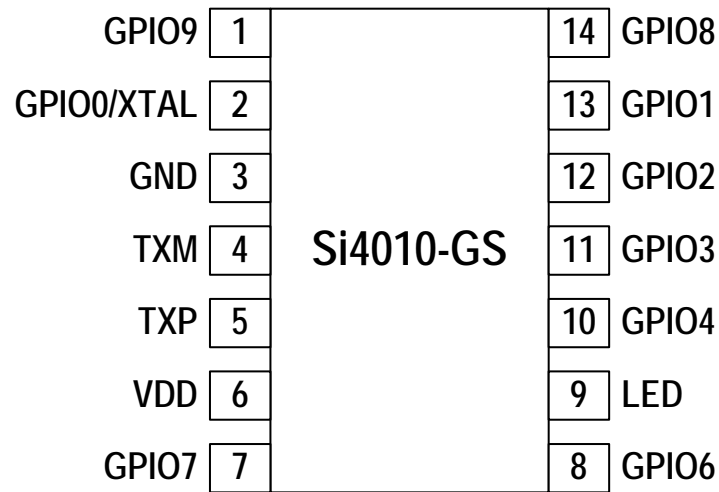

Pin Number(s)	Name	Description
1	GPIO9	General purpose input/output pin
2	GPIO0/XTAL	General purpose input pin. Can be configured as an input pin for a crystal
3	GND	Ground. Connect to ground plane on PCB
4,5	TXM, TXP	Transmitter differential outputs
6	VDD	Power
7,8	GPIO[7:6]	General purpose input/output pins
9	LED	Dedicated LED driver
10,11,12,13	GPIO[4:1]	General purpose input/output pins
14	GPIO8	General purpose input/output pin

# Si4010-C2

## 6.4. SOIC Package, Programming/debug Mode

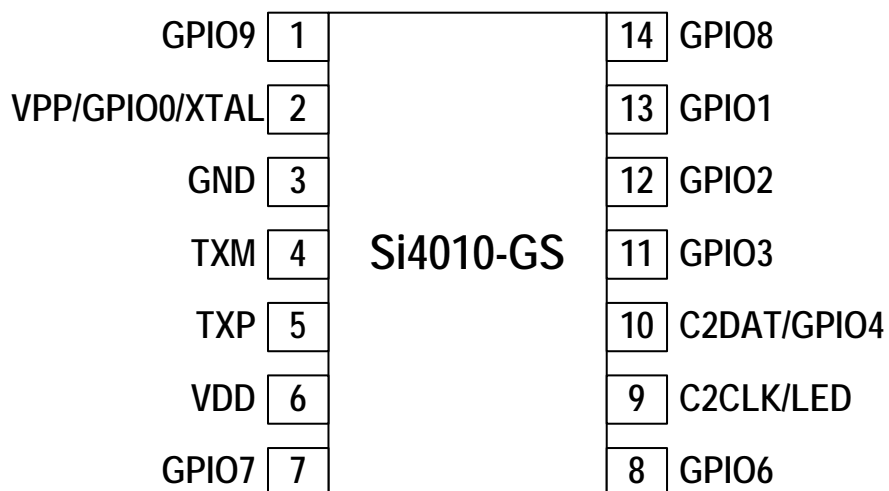

Pin Number(s)	Name	Description
1	GPIO9	General purpose input/output pin
2	VPP	+6.5 V required for NVM (OTP) Memory programming
3	GND	Ground. Connect to ground plane on PCB
4,5	TXM, TXP	Transmitter differential outputs
6	VDD	Power
7,8	GPIO[7:6]	General purpose input/output pins
9	C2CLK	C2 clock interface
10	C2DAT	C2 data input/output pin
11,12,13	GPIO[4:1]	General purpose input/output pins
14	GPIO8	General purpose input/output pin

## 7. Package Specifications

### 7.1. 10-Pin MSOP

Figure 7.1 illustrates the package details for the Si4010, 10-pin MSOP package. Table 7.1 lists the values for the dimensions shown in the illustration.

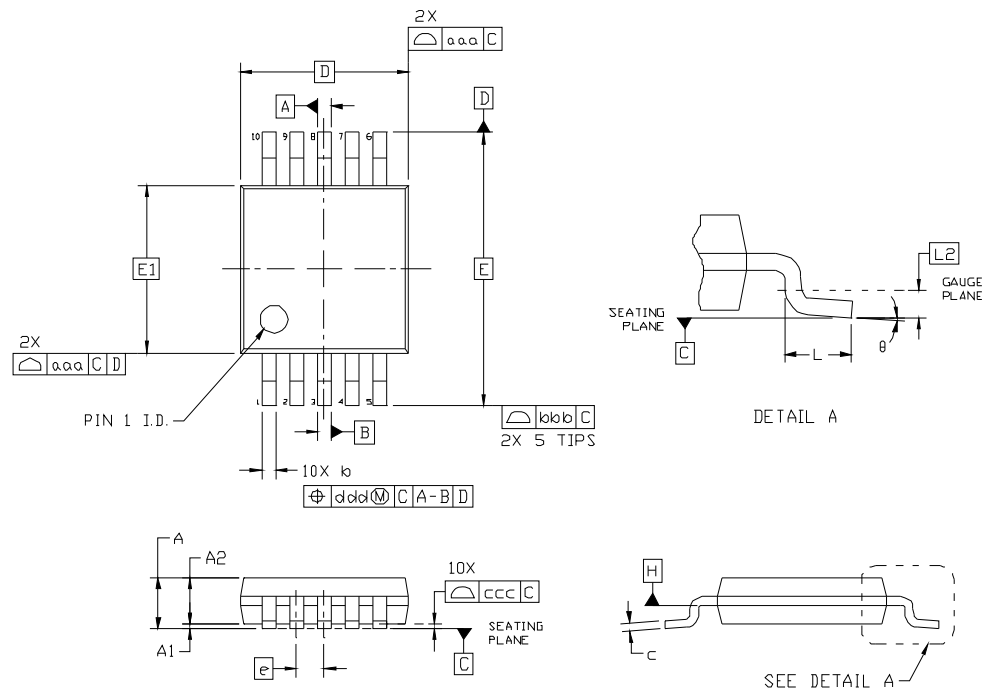

Figure 7.1. 10-Pin MSOP Package

Table 7.1. Package Dimensions

Symbol	Millimeters		
	Min	Nom	Max
A	—	—	1.10
A1	0.00	—	0.15
A2	0.75	0.85	0.95
b	0.17	—	0.33
c	0.08	—	0.23
D	3.00 BSC		
E	4.90 BSC		
E1	3.00 BSC		

Symbol	Millimeters		
	Min	Nom	Max
e	0.50 BSC		
L	0.40	0.60	0.80
L2	0.25 BSC		
q	0°	—	8°
aaa	—	—	0.20
bbb	—	—	0.25
ccc	—	—	0.10
ddd	—	—	0.08

**Notes:**

1. All dimensions are shown in millimeters (mm).
2. Dimensioning and tolerancing per ASME Y14.5M-1994.
3. This drawing conforms to JEDEC Outline MO-187, Variation "BA."
4. Recommended card reflow profile is per the JEDEC/IPC J-STD-020 specification for Small Body Components.

# Si4010-C2

## 7.2. 14-pin SOIC Package

Figure 7.2 illustrates the package details for the Si4010, 14-pin SOIC package. Table 7.2 lists the values for the dimensions shown in the illustration.

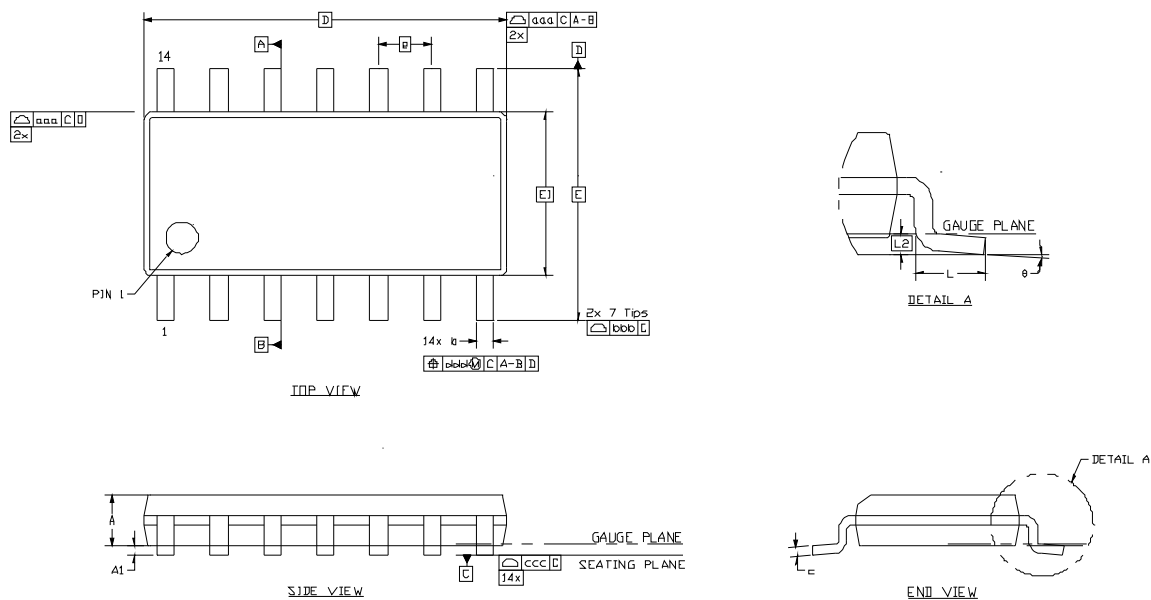

Figure 7.2. 14-Pin SOIC Package

Table 7.2. Package Dimensions

Symbol	Min	Max	Symbol	Min	Max
A	—	1.75	L	0.40	1.27
A1	0.10	0.25	L2	0.25 BSC	
b	0.33	0.51	Q	0°	8°
c	0.17	0.25	aaa	0.10	
D	8.65 BSC		bbb	0.20	
E	6.00 BSC		ccc	0.10	
E1	3.90 BSC		ddd	0.25	
e	1.27 BSC				

**Notes:**

1. All dimensions are shown in millimeters (mm).
2. Dimensioning and tolerancing per ASME Y14.5M-1994.
3. This drawing conforms to JEDEC Outline MS012, variation AB.”
4. Recommended card reflow profile is per the JEDEC/IPC J-STD-020 specification for Small Body Components.

8. PCB Land Pattern 10-Pin MSOP

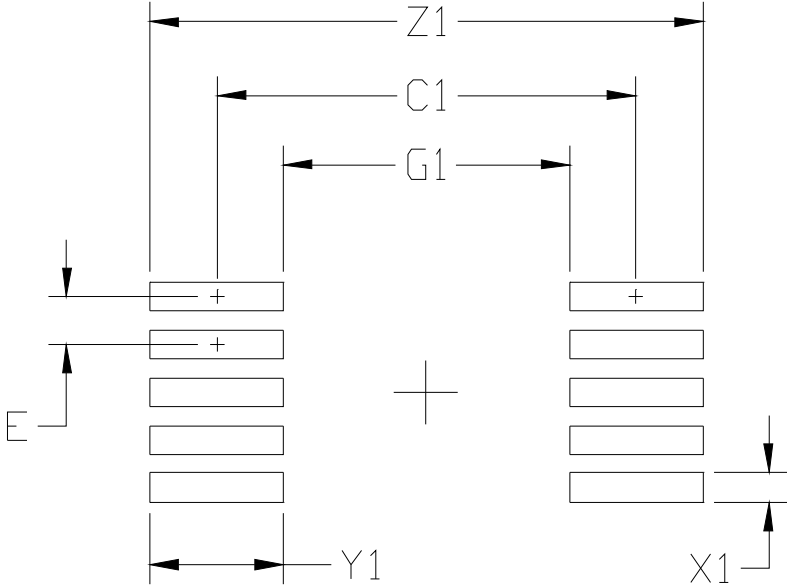

Figure 8.1. 10-Pin MSOP Recommended PCB Land Pattern



**Table 8.1. 10-Pin MSOP Dimensions**

Dimension	MIN	MAX
C1	4.40 REF	
E	0.50 BSC	
G1	3.00	—
X1	—	0.30
Y1	1.40 REF	
Z1	—	5.80

**Notes:**

**General**

1. All dimensions shown are in millimeters (mm) unless otherwise noted.
2. Dimensioning and Tolerancing per ASME Y14.5M-1994.
3. This Land Pattern Design is based on the IPC-7351 guidelines.
4. All dimensions shown are at Maximum Material Condition (MMC). Least Material Condition (LMC) is calculated based on a Fabrication Allowance of 0.05mm.

**Solder Mask Design**

1. All metal pads are to be non-solder mask defined (NSMD). Clearance between the solder mask and the metal pad is to be 60 m minimum, all the way around the pad.

**Stencil Design**

1. A stainless steel, laser-cut and electro-polished stencil with trapezoidal walls should be used to assure good solder paste release.
2. The stencil thickness should be 0.125mm (5 mils).
3. The ratio of stencil aperture to land pad size should be 1:1.

**Card Assembly**

1. A No-Clean, Type-3 solder paste is recommended.
2. The recommended card reflow profile is per the JEDEC/IPC J-STD-020 specification for Small Body Components.

9. PCB Land Pattern 14-pin SOIC Package

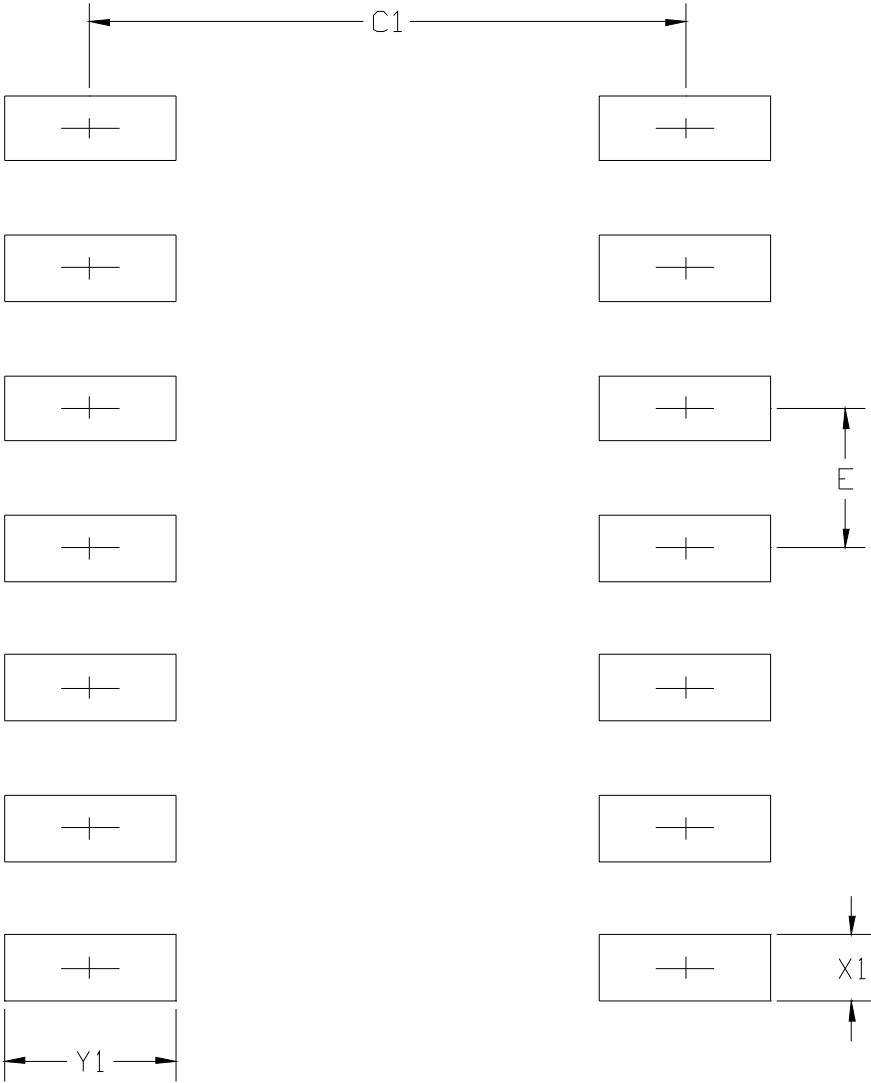

Figure 9.1. 14-Pin SOIC Recommended PCB Land Pattern

**Table 9.1. PCB Land Pattern Dimensions**

Dimension	MIN	MAX
C1	5.30	5.40
E	1.27 BSC	
X1	0.50	0.60
Y1	1.45	1.55

**Notes:**

**General**

1. All dimensions shown are in millimeters (mm) unless otherwise noted.
2. This land pattern design is based on the IPC-7351 guidelines.

**Solder Mask Design**

1. All metal pads are to be non-solder mask defined (NSMD). Clearance between the solder mask and the metal pad is to be 60  $\mu$ m minimum, all the way around the pad.

**Stencil Design**

1. A stainless steel, laser-cut and electro-polished stencil with trapezoidal walls should be used to assure good solder paste release.
2. The stencil thickness should be 0.125 mm (5 mils).
3. The ratio of stencil aperture to land pad size should be 1:1 for all perimeter pads.

**Card Assembly**

1. A No-Clean, Type-3 solder paste is recommended.
2. The recommended card reflow profile is per the JEDEC/IPC J-STD-020 specification for Small Body Components.

## 10. Electrical Characteristics

**Table 10.1. Recommended Operating Conditions**

Parameter	Symbol	Test Condition	Min	Typ	Max	Unit
Supply Voltage	$V_{DD}$		1.8	—	3.6	V
Supply Voltage Slew Rate		Initial Battery Insertion*	20	—	650	mV/ us
Ambient Temperature	$T_A$		-40	25	85	°C
Digital Input Range		Digital Input Signals	-0.3	—	$V_{DD} + 0.3$	V

\*Note: Recommend bypass capacitor = 1  $\mu$ F; slew rate measured  $1\text{ V} < V_{DD} < 1.7\text{ V}$ .

**Table 10.2. Absolute Maximum Ratings<sup>1,2</sup>**

Parameter	Symbol	Value	Unit
Supply Voltage	$V_{DD}$	-0.5 to 3.9	V
Input Current <sup>3</sup>	$I_{IN}$	10	mA
Input Voltage <sup>4</sup>	$V_{IN}$	-0.3 to ( $V_{DD} + 0.3$ )	V
Junction Temperature	$T_J$	-40 to 90	°C
Storage Temperature	$T_{STG}$	-55 to 150	°C

**Notes:**

1. Permanent device damage may occur if the absolute maximum ratings are exceeded. Functional operation should be restricted to the conditions as specified in the operational sections of this data sheet. Exposure beyond recommended operating conditions for extended periods may affect device reliability.
2. Handling and assembly of these devices should only be done at ESD-protected workstations.
3. All input pins besides  $V_{DD}$ .
4. For GPIO pins configured as inputs.

# Si4010-C2

**Table 10.3. DC Characteristics**

(TA = 25° C, VDD = 3.3 V, RL = 480 Ω, unless otherwise noted)

Parameter	Symbol	Test Condition	Min	Typ	Max	Unit
Supply Current <sup>1</sup>	I <sub>VDD</sub>	+10 dBm output, OOK, Manchester	—	14.2	—	mA
		+6.5 dBm output, OOK, Manchester	—	11.3	—	mA
		+10 dBm, FSK	—	19.8	—	mA
		+6.5 dBm output, FSK	—	14.1	—	mA
Sleep Timer Mode	I <sub>ST</sub>	Only sleep timer is enabled	—	700	—	nA
Standby Supply Current	I <sub>SB</sub>	All GPIO floating or held high	—	10	—	nA
LED Sink Current	I <sub>LED</sub>	V <sub>OUT</sub> > 200 mV	—	0.68	—	mA
GPIO[0-9] Pull Up Resistance	R <sub>PU</sub>		48	55	62	kΩ
High Level Input Voltage <sup>2</sup>	V <sub>IH</sub>	Trip point at 0.45 x V <sub>DD</sub>		0.506 x V <sub>DD</sub>		V
Low Level Input Voltage <sup>2</sup>	V <sub>IL</sub>	Trip point at 0.45 x V <sub>DD</sub>		0.42 x V <sub>DD</sub>		V
High Level Input Current <sup>2</sup>	I <sub>IH</sub>	V <sub>IN</sub> = V <sub>DD</sub>	—	—	10	μA
Low Level Input Current <sup>2</sup>	I <sub>IL</sub>	V <sub>IN</sub> = 0	—	—	10	μA
High Level Output Voltage <sup>3</sup>	V <sub>OH</sub>	I <sub>SOURCE</sub> = 500 μA	3.0	—	—	V
Low Level Output Voltage <sup>3</sup>	V <sub>OL</sub>	I <sub>SINK</sub> = 500 μA	—	—	0.3	V
<b>Notes:</b>						
1. Tested at 100 MHz carrier.						
2. For GPIO pins configured as inputs. Pullup resistor disabled.						
3. For GPIO pins configured as outputs.						

**Table 10.4. Si4010 RF Transmitter Characteristics**

(TA = 25° C, VDD = 3.3 V, RL = 480 Ω, SOIC package unless otherwise noted)

Parameter	Symbol	Test Condition	Min	Typ	Max	Unit
Frequency Range <sup>1</sup>	F <sub>RF</sub>		27	—	960	MHz
Frequency Noise (rms) <sup>2</sup>		Allen deviation, measured across 1 ms interval	—	0.3	—	ppm
Phase Noise @ 915 MHz		10 kHz offset	—	-70	—	dBc/Hz
		100 kHz offset	—	-100	—	dBc/Hz
		1 MHz offset	—	-105	—	dBc/Hz
Frequency Tuning Time			—	5	—	ms
Carrier Frequency Accuracy		0 °C ≤ T <sub>A</sub> ≤ 70° C	-150	—	+150	ppm
		-40 °C ≤ T <sub>A</sub> ≤ 85° C	-250	—	+250	ppm
Frequency Error Contribution with External Crystal			-10	—	+10	ppm
Transmit Power <sup>3</sup>		Maximum programmed TX power, with optimum differential load, V <sub>DD</sub> > 2.2 V	—	10	—	dBm
		Minimum programmed TX power, with optimum differential load, V <sub>DD</sub> > 2.2 V	—	-13	—	dBm
		Power variation vs temp and supply, with optimum differential load, V <sub>DD</sub> > 2.2 V	-1.0	—	0.5	dB
		Power variation vs temp and supply, with optimum differential load, V <sub>DD</sub> > 1.8 V	-2.5	—	0.5	dB
		Transmit power step size from -13 to 10 dBm	—	0.25	—	dB
PA Edge Ramp Rate Programmable Range		OOK mode	0.34	—	10.7	us
Data Rate		OOK, Manchester encoding	0.1	—	50	kBaud
		FSK, NRZ encoding	0.1	—	100	kBaud

**Notes:**

1. The frequency range is continuous over the specified range.
2. The frequency step size is limited by the frequency noise.
3. Optimum differential load is equal to  $3.5 \text{ V} / (11.5 \text{ mA} / 2 \times 4 / \pi) = 480 \Omega$ . Therefore the antenna load resistance in parallel with the Si4010 differential output resistance should equal 480 Ω.
4. Total NVM copy time = 2 ms + (NVM copy Boot Time per kB) x (NVM data in kB).

# Si4010-C2

**Table 10.4. Si4010 RF Transmitter Characteristics(Continued)**

(TA = 25° C, VDD = 3.3 V, RL = 480 Ω, SOIC package unless otherwise noted)

Parameter	Symbol	Test Condition	Min	Typ	Max	Unit
Peak to Peak FSK Deviation		Max frequency deviation	—	275	—	ppm
		Deviation resolution	—	2	—	ppm
		Deviation accuracy	±(4 ppm + 2% pk-pk target FSK deviation in ppm)			ppm
OOK Modulation depth			60	—	—	dB
Antenna Tuning Capacitive Range (Differential)		315 MHz	2.4	—	12.5	pF
NVM Copy Boot Time per kB <sup>4</sup>			—	3.6	—	ms/ kB
<b>Notes:</b> <ol style="list-style-type: none"> <li>1. The frequency range is continuous over the specified range.</li> <li>2. The frequency step size is limited by the frequency noise.</li> <li>3. Optimum differential load is equal to <math>3.5 V / (11.5 mA / 2 \times 4 / \pi) = 480 \Omega</math>. Therefore the antenna load resistance in parallel with the Si4010 differential output resistance should equal 480 Ω.</li> <li>4. Total NVM copy time = 2 ms + (NVM copy Boot Time per kB) x (NVM data in kB).</li> </ol>						

**Table 10.5. Low Battery Detector Characteristics**

(TA = 25° C, VDD = 3.3 V, RL = 480 Ω, unless otherwise noted)

Parameter	Symbol	Test Condition	Min	Typ	Max	Unit
Battery Voltage Measurement Accuracy			—	2	—	%

**Table 10.6. Optional Crystal Oscillator Characteristics**

(TA = 25° C, VDD = 3.3 V, RL = 480 Ω, unless otherwise noted)

Parameter	Symbol	Test Condition	Min	Typ	Max	Unit
Crystal Frequency Range		GPIO0 configured as crystal oscillator	10	—	13	MHz
Input Capacitance (GPIO0)		GPIO0 configured as a crystal oscillator; XO_LOWCAP=1	—	3	—	pF
		GPIO0 configured as a crystal oscillator; XO_LOWCAP=0	—	5.5	—	pF
Crystal ESR		GPIO0 configured as a crystal oscillator; XO_LOWCAP=1	—	—	120	Ω
		GPIO0 configured as a crystal oscillator; XO_LOWCAP=0	—	—	80	Ω
Start-up Time		GPIO0 configured as a crystal oscillator; Crystal at Max ESR	—	9	50	ms

**Table 10.7. EEPROM Characteristics**

Parameter	Conditions	Min	Typ	Max	Units
Program Time	Independent of number of bits changing values	—	8	40	ms
Count per 32-Bit Counter	Using API	—	1000000	1000100	cycles
Write Endurance (per bit)*		50000	—	—	cycles

**Note:** \*API uses coding technique to achieve write endurance of 1M cycles per bit.

**Table 10.8. Low Power Oscillator Characteristics**

$V_{DD} = 1.8$  to  $3.6$  V;  $T_A = -40$  to  $+85$  °C unless otherwise specified. Use factory-calibrated settings.

Parameter	Conditions	Min	Typ	Max	Units
Programmable Frequency Range	Programmable divider in powers of 2 up to 128	.1875	—	24	MHz
Frequency Accuracy		-1	—	+1	%

**Table 10.9. Sleep Timer Characteristics**

$V_{DD} = 1.8$  to  $3.6$  V;  $T_A = -40$  to  $+85$  °C unless otherwise specified. Use factory-calibrated settings.

Parameter	Conditions	Min	Typ	Max	Units
Maximum Programmable Time		—	—	6800	s
Time Accuracy	Using API to program timer	-1.5	—	1.5	%



## 10. System Overview

## 11. Low Power Oscillator and System Clock Generator

The source of all digital system clocks is derived from the low power oscillator (LPOSC) and system clock generator. The LPOSC produces a 24MHz clock signal and is used by the system clock generator to produce the system clock. This system clock is applied to all digital blocks including the MCU and is programmable via the SYSGEN SFR register which is useful for power savings.

### SFR Definition 11.1. LPOSC\_TRIM

Bit	7	6	5	4	3	2	1	0
<b>Name</b>	LPOSC_trim[7:0]							
<b>Type</b>	R/W							
<b>Reset</b>	1	1	1	1	1	1	1	1

SFR Address = 0x4002

Bit	Name	Function
7:0	LPOSC_trim[7:0]	<b>Low Power Oscillator Trimming.</b> ±16 % range with 0.14 % resolution.

### SFR Definition 11.2. SYSGEN

Bit	7	6	5	4	3	2	1	0
<b>Name</b>	sysgen_shutdown	sysgen_unused	pwr_1st_time	rtc_tickclr	port_hold	sysgen_div[2:0]		
<b>Type</b>	R/W	R	R	W	R/W	R/W		
<b>Reset</b>	0	0	—	0	0	0	0	1

SFR Address = 0xBE

# Si4010-C2

Bit	Name	Function
7	sysgen_shutdown	<b>System Generator Shutdown.</b> Setting this causes shutdown of MCU and most analog. Recovery from this is via falling edge on any GPIO, which results in a power up and a power on reset. This is THE bit that shuts down the power to nearly everything. Must be protected in scan.
6	sysgen_unused	<b>Reserved.</b> Read as 0. Write has no effect.
5	pwr_1st_time	<b>Initial Powerup Indicator.</b> Read only register. It will get set when the power up was caused by battery insertion.
4	rtc_tickclr	<b>Real Time Clock Clear.</b> Writing 1 to this bit clears the real time clock 5.12us tick counter. It must be registered.
3	port_hold	<b>Port Hold.</b> For GPIO control to control the latch during shutdown. It goes directly to analog.
2:0	sysgen_div [2:0]	<b>System Generator Divider.</b> System clock divider control to generate clk_sys. Divides the analog 25MHz ck_25 cheap oscillator. Any transition in control states is allowed, result in glitch-less transitions in the generated clk_sys: $F_{sys} \sim 25\text{MHz}/2^{\text{sysgen\_div}}$ . This signal must be masked in scan as 3'b001. Needed internally, so it is masked in dig_anaout.v module.

**Table 11: sysgen\_div encoding**

Value	Description
0	25 MHz; div=1
1	12.5MHz; div=2
2	6.25MHz; div=4
3	3.13MHz; div=8
4	1.56Mhz; div=16
5	0.78MHz; div=32
6	0.39MHz; div=64
7	0.20MHz; div=128

Note that the numbers in the previous table should all be scaled by 24/25.

---

## 12. Sleep Timer

The Si4010 includes a very low-power sleep timer that can be used to support the transmit duty cycle requirements of the ETSI specification or self-wakeup for button independent applications. It consist of a low speed (~9kHz), very lower oscillator with a 26 bit down counter. The bottom 2 bits are not visible to the programming interface (24 bits wide), so it appears to run at ~2.1kHz. When programmed to its maximum interval it takes ~2.1 hours to count down to zero.

When it counts down to zero, it automatically powers down completely. Depending on the state of a control bit, it may produce a pulse which turns on the chip if the chip was powered down.

???? How do we enable it, does it provide an interrupt when completed, how do we set the timer value, how do we reset it? Where is the control bit to enable self-wakeup mode?

# Si4010-C2

## 13. Low Leakage RAM (L2RAM)

The L2RAM provides 8 bytes of RAM memory which keeps its contents in all states including shut down as long as the supply voltage is applied to the chip. The block consists of an 8-bit input data bus, 3-bit address selection, and an 8-bit output data bus. The device is controlled by the L2RAM\_CTRL SFR register and data is written or read from the L2RAM\_DATA SFR register.

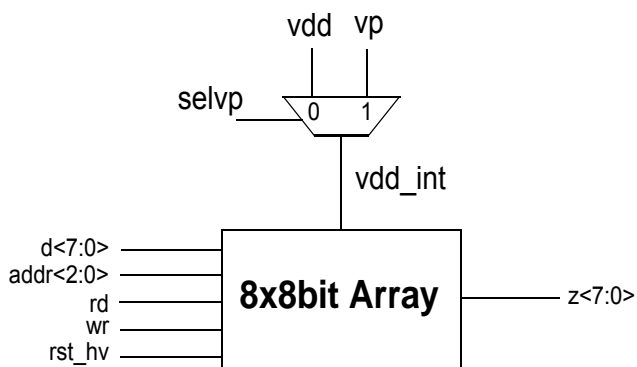

Figure 13.1. HVRAM Block Diagram

### 13.0.1. Register Interface

#### SFR Definition 13.1. HVRAM\_CTRL

Bit	7	6	5	4	3	2	1	0
<b>Name</b>	hvramp_ena	hvramp_rd	hvramp_wr	hvramp_unused[4:3]		hvramp_addr[2:0]		
<b>Type</b>	R/W	R/W	R/W	R		R/W		
<b>Reset</b>	0	0	0	0		0		

SFR Address = 0xC4

Bit	Name	Function
7	hvrām_ena	<b>Enable for HVRAM.</b> Must be set prior to reading or writing, must extend beyond end of write.
6	hvrām_rd	<b>Read Enable for HVRAM.</b> Read data becomes valid 2 cycles after assertion of read control. Recommended usage would be to write 1 to this bit twice in a row and then read the HVRAM_DATA register. This approach would guarantee stable data timing.
5	hvrām_wr	<b>Write enable.</b> Address and data must be stable one cycle prior to and one cycle after the write.
4:3	hvrām_ unused[4:3]	<b>Reserved.</b> Read as 0x0. Write has no effect.
2:0	hvrām_addr [2:0]	<b>Address for HVRAM.</b>

### SFR Definition 13.2. HVRAM\_DATA

Bit	7	6	5	4	3	2	1	0
<b>Name</b>	hvrām_data[7:0]							
<b>Type</b>	R/W							
<b>Reset</b>	0							

SFR Address = 0xC5

Bit	Name	Function
7:0	hvrām_ - data[7:0]	<b>HVRAM Data.</b> Write data to a holding register from which HV RAM will take data when HVRAM_WR is toggled. Read returns current value of the HVRAM data output. User must set HVRAM_RD to 1 to enable the read and wait at least two CPU clock cycles, otherwise the read data is invalid.

# Si4010-C2

---

## 14. VCO

The Si4010 VCO is a fully integrated CMOS VCO that operates at approximately 3.8 GHz. This block in conjunction with a programmable frequency divider generates the transmit carrier frequency. The technology behind the VCO is based on the Silicon Laboratories Si500 crystal-less oscillator chip and forms the core of the Si4010s' crystal-less operation. After this device is factory trimmed, the VCO frequency is the most accurate frequency on the chip and sets the chips transmit frequency stability unless an external crystal oscillator is used. The device achieves  $\pm 150$  ppm frequency stability over the temperature range of 0 to 70°C and  $\pm 250$  ppm frequency stability over the temperature range of -40 to 85°C.

The transmit carrier frequency is set by using our `FREQ_TUNE` API command. For FSK modulation, the `VCO_FSK` register is used to set the frequency deviation.

Frequency deviation =  $2\text{ppm} * \text{VCO\_FSK}[6:0]$

????Need to add frequency tune (casting), selection of frequencies for Chamberlain. Do we need to add `LC_COARSE` and `LC_DIVIDER` registers?

## 15. Frequency Counter

The frequency counter allows the measurement of the ratio of two selected clock sources: a low frequency clock which defines the clock interval, and a high frequency clock which is counted. The high frequency clock source can be either the VCO frequency or the divider output which is the transmit carrier frequency. The selection of the high frequency clock is with the FC\_HFC bit in the FC\_CTRL SFR register. The low frequency clock source which defines the clock interval can be selected from several sources such as an external clock reference from a GPIO pin, the 24MHz low power oscillator, the system clock (MCU clock), or from the optional crystal oscillator through the FC\_MODE[2:0] bits in the FC\_CTRL SFR registers.

Writing the FC\_BUSY bit to 1 starts a frequency counting cycle. The frequency counter is restartable, so re-writing a 1 to the FC\_BUSY bit restarts the frequency counter and discards what the frequency counter was previously doing. When the FC\_BUSY bit is read, a 1 signifies the frequency counter is busy counting. The falling edge of the FC\_BUSY signal sets the FC\_DONE bit to 1.

The count interval is chosen with the FC\_INTERVAL SFR register. The number of interval count cycles (count cycles of the low frequency clock) =  $(2 + FC\_INTERVAL[0]) * (2^{FC\_INTERVAL[5:1]})$ . Note, FC\_INTERVAL is not allowed to take on numbers higher than 43. If the number is higher than 43, then the interval counted is forced to 1.

???Why don't we show FC\_COUNT?

### SFR Definition 15.1. FC\_CTRL1

Bit	7	6	5	4	3	2	1	0
Name	fc_ctrl[7:0]							
Type	R/W							
Reset	0	0	0	0	0	0	0	0

SFR Address = 0x9B

Bit	Name	Function
7:0	fc_ctrl[7:0]	Frequency Counter Control Register.

# Si4010-C2

## SFR Definition 15.2. FC\_CTRL2

Bit	7	6	5	4	3	2	1	0
Name	fc_done	fc_busy	fc_div_sel	fc_unused[4:3]		fc_mode[2:0]		
Type	R/W	R/W	R/W	R		R/W		
Reset	0	0	0	0		0		

SFR Address = 0x9B

Bit	Name	Function
7	fc_done	<p><b>Frequency Counter Done.</b></p> <p>Counting done, interrupt generation level signal. Must be cleared by software ISR. It is also cleared if 1 is written to fc_busy, which denotes the start of the next count. Any value can be written here, so one can invoke interrupt just writing 1 here.</p>
6	fc_busy	<p><b>Frequency Counter Busy.</b></p> <p>Frequency counter is busy counting. Falling edge of the fc_busy signal sets the fc_done=1. Writing 1 to this bit triggers a new FC counting cycle. FC is restartable, so any Wr 1 to this bit restarts the FC and discards what the FC was currently doing.</p>
5	fc_div_sel	<p><b>Frequency Counter Divider Select.</b></p> <p>Selection control of source of clock to high speed divider in analog. It chooses between LC and MPLL. It drives the analog control signals div_fcnt_sel_lc and mpll_ena_fcnt. If the frequency counter is not enabled, FC_MODE=0, then both signals mentioned above are in their inactive states. Bit value of this field:</p> <p>0 .. LC 1 .. MPLL</p>
4:3	fc_unused [4:3]	<p><b>Reserved.</b></p> <p>Read as 0x0. Write has no effect.</p>
2:0	fc_mode [2:0]	<p><b>Frequency Counter Mode Control Register.</b></p>



**SFR Definition 15.3. FC\_INTERVAL**

Bit	7	6	5	4	3	2	1	0
<b>Name</b>	fc_interval[5:0]							
<b>Type</b>	R/W							
<b>Reset</b>	0							

SFR Address = 0x9D

Bit	Name	Function
5:0	fc_interval [5:0]	<p><b>Frequency Counter Interval.</b> Controls number of interval clock cycles in an interval.</p> $n\_cycles = (2+fcnt\_interval[0]) \cdot (2^{fcnt\_interval[5:1]})$ <p>Note that fcnt_interval is allowed to take on values no higher than 43. If the number higher than 43 is used then the the interval counted is forced to n_cycles = 1.</p>

**Table 12: fc\_mode encoding**

Value	Description
0	Disabled (turned off, clock disabled)
1	Interval: clk_ref .. reference clock from GPIO
2	Interval: clk_osc .. undivided output of CHOSC (25MHz)
3	Interval: clk_sys .. system clock, divided CHOSC
4	Interval: clk_xo .. XO oscillator
5	Interval: test_mux_dout .. test mux output
6	Interval: uctim_dout .. timer output
7	Interval: Pulse mode, using the GPIO output pulse to count between rising and falling edge of the pulse. The pulse is generated specifically for capacitive sensing. GPIO must be put in special test mode and the pulse can be generated for a single GPIO at a time.

# Si4010-C2

---

## 16. Power Amplifier

The CMOS power amplifier (PA) is a differential open drain amplifier capable of delivering +10 dBm of output power to a 750 differential load. The output drive level is adjusted with register PA\_LVL0[6:0] ??? with a range in value from 0 (minimum output power) to 77 (maximum output power) with each step corresponding to approximately 0.25 dB change in output power. Impedance matching, biasing, and proper layout techniques are all necessary to ensure optimal performance. Figure X shows a typical application schematic of the Si4010 with the associated matching circuitry for a differential loop antenna with an impedance of 750. Application note "AN369: Antenna Interface for the Si401x Transmitters" provides detailed information about designing the antenna interface for the Si401X transmitters. With proper filtering and layout techniques, the Si4010 can conform to US FCC part 15.231 and European EN 300 220 regulations. Users must comply with local radio frequency transmission regulations.

Variations in the transmit center frequency due to off-chip capacitor tolerances, loop antenna manufacturing tolerances, and environmental variations can lead to large antenna inefficiencies and wasted power especially in high-Q power amplifiers. The Si4010 includes an automatic antenna tuning circuit to improve the antenna efficiency of the transmitter. The PA output has 2.6 to 20pF of variable capacitance that is adjusted to tune the antenna to the correct frequency using a patented phase detection algorithm. The variable capacitance is automatically adjusted at the start of each packet transmission. The switching network in the capacitor array is compensated over process, voltage, and temperature (PVT) to keep its Q factor nearly constant at 50. The default value of the 9-bit capacitor word is 256 (middle of the 9-bit range) and can be manually over-written by writing to register PA\_CAP[8:0].

In OOK operation, wave shaping is accomplished by gradually turning on and off the programmable driver transistors with register ????.

Software control is used to keep the radiated power constant over PVT by monitoring the 9-bit word used to control the capacitor array as well as the temperature and adjusting the nominal drive level through first-order linear correction techniques.

16.0.1. Simplified Block Diagram

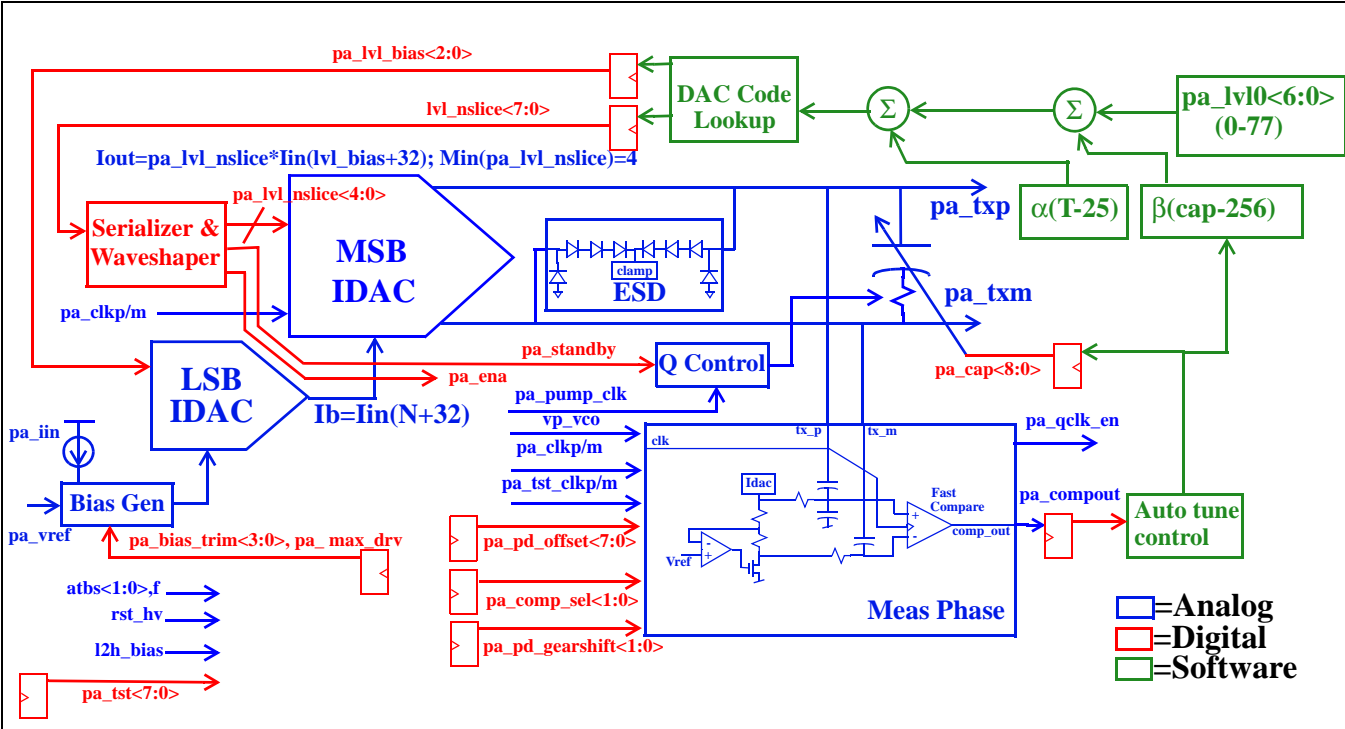

Figure 4. Block diagram of PA showing basic architectural details.

# Si4010-C2

## 16.0.2. Register Interface

### SFR Definition 16.1. PA\_LV

Bit	7	6	5	4	3	2	1	0
Name	pa_lvl_nslice[7:3]					pa_lvl_bias[2:0]		
Type	R/W					R/W		
Reset	0					0		

SFR Address = 0xCE

Bit	Name	Function
7:3	pa_lvl_nslice[7:3]	<b>Number of slices to enable in PA driver.</b> This is generally an input to the serializer, which passes the full value along to the PA (with the name pa_lvl_nslice) during FSK, OOK 1 bits, and during assertion of ser_pa_bias. This, along with pa_lvl_bias, is generally produced as the output of a look up table based on pa_lvl0 and other (temperature, capacitance, clipping) factors.
2:0	pa_lvl_bias[2:0]	<b>PA Bias.</b> Bias current per slice of the PA is proportional to (32+pa_lvl_bias) This, along with pa_lvl_nslice, is generally produced as the output of a look up table based on pa_lvl0 and other (temperature, capacitance, clipping) factors.

---

**SFR Definition 16.2. PA\_CAP**

---

<b>Bit</b>	<b>7</b>	<b>6</b>	<b>5</b>	<b>4</b>	<b>3</b>	<b>2</b>	<b>1</b>	<b>0</b>
<b>Name</b>	pa_cap[9:0]							
<b>Type</b>	R/W							
<b>Reset</b>	0	0	0	0	0	0	0	0

<b>Bit</b>	<b>15</b>	<b>14</b>	<b>13</b>	<b>12</b>	<b>11</b>	<b>10</b>	<b>9</b>	<b>8</b>
<b>Name</b>	pa_cap[9:0]							
<b>Type</b>	R/W							
<b>Reset</b>								1

SFR Address = 0x400C

<b>Bit</b>	<b>Name</b>	<b>Function</b>
15:0	pa_cap[9:0]	<b>PA Capacitance.</b> Linear control of additive load capacitance in 3-20pF (not exact values) single ended. Control word to nominally set the antenna center frequency. Can be adjusted via software prior to preamble transmission to fine tune over PVT.

# Si4010-C2

---

## SFR Definition 16.3. PA\_PD\_OFFSET

---

Bit	7	6	5	4	3	2	1	0
Name	pa_pd_offset[7:0]							
Type	R/W							
Reset	1	0	0	0	0	0	0	0

SFR Address = 0x400E

Bit	Name	Function
8:0	pa_pd_offset[7:0]	<b>PA Phase Detection Offset.</b> This controls a differential DAC which offsets the signal applied to the comparator used for phase detection and voltage sensing. Full scale is ~ +/-1V, 1 lsb ~ 7.9mV. The reset state of 128 disables the comparator and DAC.

---

## SFR Definition 16.4. PA\_PD\_GEARSHIFT

---

Bit	7	6	5	4	3	2	1	0
Name							pa_pd_gearshift[2:0]	
Type							R/W	
Reset							0	

SFR Address = 0x400F

Bit	Name	Function
1:0	pa_pd_gearshift [1:0]	<b>PA Phase Detection and Voltage Sensing.</b> This controls a capacitive attenuator which feeds the comparator used for phase detection and voltage sensing.

**SFR Definition 16.5. PA\_PD\_GEARSHIFT**

Bit	7	6	5	4	3	2	1	0	
Name								pa_pd_gearshift[2:0]	
Type								R/W	
Reset								0	

SFR Address = 0x400F

Bit	Name	Function
1:0	pa_pd_gearshift [1:0]	<b>PA Phase Detection and Voltage Sensing.</b> This controls a capacitive attenuator which feeds the comparator used for phase detection and voltage sensing.

**SFR Definition 16.6. PA\_TST**

Bit	7	6	5	4	3	2	1	0
Name	pa_tst[7:0]							
Type	R/W							
Reset	0	0	0	0	0	0	0	0

SFR Address = 0x4010

Bit	Name	Function
7:0	pa_tst	<b>Test bits for PA.</b>

**SFR Definition 16.7. PA\_COMP\_SEL**

Bit	7	6	5	4	3	2	1	0	
Name								pa_comp_sel[1:0]	
Type	R/W								
Reset	0	0	0	0	0	0	0	0	

SFR Address = 0x4011

# Si4010-C2

Bit	Name	Function
7:2	Unused	Unused.
1:0	pa_comp_sel[1:0]	Comparator Output Mode Selection for PA.

## SFR Definition 16.8. PA\_TRIM

Bit	7	6	5	4	3	2	1	0
Name				pa_max_drv	pa_bias_trim[3:0]			
Type	R/W			R/W	R/W			
Reset	0	0	0	0	1	0	0	0

SFR Address = 0x4012

Bit	Name	Function
7:2	Unused	Unused.
1:0	pa_comp_sel[1:0]	Comparator Output Mode Selection for PA.

**Table 13: pa\_pd\_gearshift encoding**

Value	Description
0	Minimal attenuation of 0.6x
1	Atten of ~0.4x
2	Atten to ~0.31x
3	Atten to ~0.25x

**Table 14: pa\_tst\_4LSBs encoding**

Value	Description
0	Normal operation
1	Freeze charge pump clk and sense voltage drop across replica poly resistor on atbs<1>.
2	Sense average voltage across poly and device resistors on atbs<1>. Allows measurement of offset between device and poly resistance.
3	Enable qreg charge pump updates onto pa_compout and leave leakage current unchanged in charge pump.



Table 14: pa\_tst\_4LSBs encoding

Value	Description
4	Enable qreg charge pump updates onto pa_compout and disable leakage current in charge pump.
5	Sense charge pump output on atbs<1>.
6	Enable quadrature clock from MPLL for cap-array testing. Also enables atbs<1> and atbs<0> for sensing phase difference between PA outputs and quadrature clock via analog EXOR gate (Gilbert cell).
7	Sense differential duty cycle of delayed pa_clk used for amplitude measurement.
8	Enable force and sense across resistor that measures amount of current drawn by source follower clamp devices in PA. There are 2 possible modes: 1). If pa_ena is low, force and sense (on atbs<1>) are enabled 2). If pa_ena is high, only sense is enabled on atbs<1>
9	Sense reference voltage for driver clamp on atbs<1>. Approximately equal to vph-1.9+Vtn_thick
10	Sense voff_p (positive comparator offset voltage) on atbs<1>
11	Sense voff_m (negative comparator offset voltage) on atbs<1>
12	Sense buffered bandgap voltage on atbs<1>
13	Sense regulated vp for msb_decode block on atbs<1>
14	Sense 1.3V reference voltage (vph referenced) on atbs<1>
15	Sense ib_drv (buffered 1.3V reference voltage) on atbs<1>

Table 15: pa\_tst\_4MSBs encoding

Value	Description
0	Normal operation
1	Sense txm output on atbs<1>
2	Sense txp output on atbs<1>
4	Force txm output on atbf
8	Force txp output on atbf
12	Disable all forcing on tx outputs and enable oscillator mode for amplitude detection

I

**Table 16: pa\_comp\_sel encoding**

Value	Description
0	Normal operation; phase detector and amplitude detection disabled
1	Phase detection mode
2	Amplitude detection mode; delay line is enabled for control by Test Core DAC.
3	Amplitude detection mode; delay line is enabled and differential exor gate is used to sense phase difference between pa_clk and its delayed version. Test Core DAC used to adjust delay until clocks are 90 degrees apart. This occurs when atbs<1>-atbs<0> is 0.

## 17. Crystal Oscillator (Optional)

The crystal oscillator produces an accurate clock reference for applications demanding a high-accuracy transmit carrier frequency. It uses a 1-pin crystal oscillator circuit (Colpitt's oscillator) and the output of signal is buffered to the frequency counter.

### 17.0.1. Register Interface

#### SFR Definition 17.1. XO\_CTRL

Bit	7	6	5	4	3	2	1	0
Name					xo_tst[3:2]		xo_lowcap	xo_ena
Type					R/W		R/W	R/W
Reset	0	0	0	0	0	0	0	0

SFR Address = 0x4016

Bit	Name	Function
7:4	Unused.	<b>Unused.</b>
3:2	xo_tst[3:2]	<b>Measurement of the XO regenerative amplifier bias current.</b>  0 .. no connection 1 .. sense 2 .. force 3 .. sense and force
1	xo_lowcap	<b>XO Low Capacitance.</b> Bit should be set for crystals that require less than 14pF of C_total capacitance.
0	xo_ena	<b>Enable XO.</b> Note that operation of the XO requires that the bandgap be enabled. The input XO_CKGOOD status bit is in the SFR SYSTEM register.

# Si4010-C2

## 18. General Purpose Input/Output (GPIO)

Ten GPIO pins on the Si4010 SOIC package (six GPIO pins on the MSOP package) are available for general purposes including detection of external button presses, external reference clock input, external clock generation, LED drive capability, accessibility by the 8051 processor, and C2/Data interface for program debugging. GPIO0 is an input only pin and GPIO5 is an output LED driver only and requires setting the proper LED driver current. All peripheral port pins are configured as inputs with a 60k $\Omega$  pull-up resistor after power-on.

### 18.0.1. Pin Translations for 10 and 14 Pin Modes

**Table 17: 10 Pin Mode**

Package Pin Number	Package Pin Name	BondPad Physical Name	Number on GPIO Intra-chip Interface
5	gpio0_xo	gpio0_xo	8
6	gpio1	gpio1	1
7	gpio2	gpio2	2
8	gpio3	gpio3	3
9	gpio4	gpio4	4
10	gpio5_c2clk	gpio5_c2clk	5
nonexistent		gpio6	6
		gpio7	7
		gpio8	0
		gpio9	9 (8 for dato and pude)

**Table 18: 14 Pin Mode**

Package Pin Number	Package Pin Name	BondPad Physical Name	Number on GPIO Intra-chip Interface
6	xo	gpio0_xo	8
9	gpio1	gpio1	1
10	gpio2	gpio2	2
11	gpio3	gpio3	3
12	gpio4	gpio4	4
13	gpio5_c2clk	gpio5_c2clk	5
14	gpio6	gpio6	6
1	gpio7	gpio7	7
8	gpio8	gpio8	0
7	gpio9	gpio9	9 (8 for dato and pude)

### 18.0.2. Implied Digital Support

Need to create the gpio\_interval signal. This pulse is high when a selected gpio pin has been driven low, is no longer being driven high, and has not yet pulled high. In the correct selection, the freq\_counter can select this as the interval across which to count, yielding a high resolution measurement of the capacitance on the selected pin.

Some signals which are apparently direct from serial bits are actually processed by the SPI2C and DIGTM blocks to allow overriding behavior.

### 18.0.3. Register Interface

Port description of P0, P1, and P2 follows.

### SFR Definition 18.1. P0

Bit	7	6	5	4	3	2	1	0
Name	p0[7:0]							
Type	R/W	R/W	R/W	R/W	R/W	R/W	R/W	R/W
Reset	1	0	0	0	0	0	0	0

SFR Address = 0x80

Bit	Name	Function
7:0	p0[7:0]	<p><b>Port 0 register, GPIO[7:0], bit addressable.</b> Write appears at the GPIO[7:0] outputs, read reads directly the GPIO input values.</p> <p>Write: 0 .. output low value 1 .. output open-drain or high drive value in push-pull mode</p> <p>Read: 0 .. GPIO pin is at logic low value 1 .. GPIO pin is at logic high value</p> <p>Special pins: The GPIO[0] is input only. Write to GPIO[0] has no effect. The GPIO[5] is output LED driver only and requires setting of the proper LED drive current. Then GPIO[5] just turns the LED current on (1) or off (0). Reading from GPIO[5] returns the user intended driver of LED (1 .. driving, 0 .. off). The read value will be read as 0 if, for example, the user writes GPIO[5] as 1, but the LED current value PORT_CTRL.PORT_LED will be 0.</p> <p>The read GPIO[5] value does not represent the actual driving status of the LED drive, since the debug logic and C2 can disable the LED. The actual LED driving status can be read as RBIT_DATA.GPIO_LED_DRIVE bit.</p>

# Si4010-C2

---

---

## SFR Definition 18.2. P0CON

---

Bit	7	6	5	4	3	2	1	0
Name	p0con[7:0]							
Type	R/W	R/W	R/W	R/W	R/W	R/W	R/W	R/W
Reset	0	0	0	0	0	0	0	0

SFR Address = 0xA4

Bit	Name	Function
7:0	p0con[7:0]	<p><b>Port 0 configuration register, for GPIO[7:0].</b></p> <p>This bit controls configuration of each corresponding output bit in P0.</p> <p>0 .. open-drain 1 .. push-pull</p> <p>If the pin to be input, it must be configured as open-drain and 1 has to be written as output value to it.</p>

**SFR Definition 18.3. P1**

Bit	7	6	5	4	3	2	1	0
Name	p1[7:0]							
Type	R/W	R/W	R/W	R/W	R/W	R/W	R/W	R/W
Reset	1	1	1	1	0	0	0	0

SFR Address = 0x90

Bit	Name	Function
7:0	p1[7:0]	<b>Port 1 register GPIO[15:8], bit addressable.</b> Write appears at the GPIO[7:0] outputs, read reads directly the GPIO input values. Same as for P0. Only GPIO[9:8] are used, write to the rest of the register has no effect, read returns 0 at those bits.

**SFR Definition 18.4. P1CON**

Bit	7	6	5	4	3	2	1	0
Name	p1con[7:0]							
Type	R/W	R/W	R/W	R/W	R/W	R/W	R/W	R/W
Reset	0	0	0	0	0	0	0	0

SFR Address = 0x5A

Bit	Name	Function
7:0	p1con[7:0]	<b>Port 1 register GPIO[15:8], bit addressable.</b> This bit controls configuration of each corresponding output bit in P1.  0 .. open-drain, pull up resistor connected (see port_roff) 1 .. push-pull, pull up resistor disabled  If the pin to be input, it must be configured as open-drain and 1 has to be written as output value to it.

# Si4010-C2

---

## SFR Definition 18.5. P2

---

Bit	7	6	5	4	3	2	1	0
Name	p2[7:0]							
Type	R/W	R/W	R/W	R/W	R/W	R/W	R/W	R/W
Reset	1	1	1	1	0	0	0	0

SFR Address = 0xA0

Bit	Name	Function
7:0	p2[7:0]	<b>Port 2 register, bit addressable.</b> It is not a port, but a regular register. This register is used as a page MSB address byte for XDATA addressing in mode, using the PDATA memory accesses. The sole purpose it is in Si6110 is to support the PDATA model.

Port control:

---

## SFR Definition 18.6. PORT\_CTRL

---

Bit	7	6	5	4	3	2	1	0
Name	port_strobe	port_roff	port_matrix	port_drv2x	port_5_midrange	port_midrange	port_led[1:0]	
Type	R/W	R/W	R/W	R/W	R/W	R/W	R/W	R/W
Reset	0	0	0	0	0	0	0	0

SFR Address = 0xB5



Bit	Name	Function
7	port_strobe	<b>Port Strobe.</b> Strobe the port_matrix and port_roff bits values from this register to the GPIO pads. The operation requires additional 2 CPU clock to finish after writing 0->1->0 to this bit. When 1 is written to this bit the GPIO latches open and the values of port_matrix and port_off are propagated to GPIO pads. Software must clear this bit to capture those two bits in the GPIO pads internal HV permanent latches.
6	port_roff	<b>Port Roff Mode.</b> Roff mode, read from this bit returns the actual Roff mode value as reported from GPIO pad. When a 1 is latched into the GPIO pad internal Roff mode HV latch then the GPIO Roff mode gets invoked. The GPIO[1:2] will have their pull-up resistors turned off. This is needed for I2C operation.
5	port_matrix	<b>Port Matrix Mode.</b> Matrix mode, read from this bit returns the actual value matrix mode value as reported from GPIO pad. When a 1 is latched into the GPIO pad internal matrix mode HV latch then the GPIO matrix mode gets invoked. The GPIO[1:3] are driven low with resistor pull-ups disabled. This is intended for matrix button mode to wake up from sleep mode.
4	port_drv2x	<b>Increase drive strength by 2x on all outputs.</b> Required for I <sup>2</sup> C, but can be used for other purposes. Set in scan mode automatically.
3	port_5_midrange	<b>Input GPIO[5] pin trip point set to 45% VDD.</b>
2	port_midrange	<b>Input GPIO pin trip point set to 45% VDD (except GPIO[5]).</b>
1:0	port_led [1:0]	<b>LED current drive strength.</b> It must be set to non-zero value for LED to have any current. This is just a current source setting. The actual turning of the LED on and off is controlled by the GPIO[5] output bit in P0.  00 .. LED off 01 .. 11 .. increasing current 0.37 to 0.97 mA

# Si4010-C2

## SFR Definition 18.7. PORT\_INTCFG

Bit	7	6	5	4	3	2	1	0
Name	neg_int1	sel_int1[6:4]			neg_int0	sel_int0[2:0]		
Type	R/W	R/W	R/W	R/W	R/W	R/W	R/W	R/W
Reset	0	0	0	0	0	0	0	0

SFR Address = 0xB7

Bit	Name	Function
7	neg_int1	<p><b>Negative INT0 polarity.</b>            This bit selects whether the selected INT0 GPIO input will get inverted or pass as is before going to the edge detector.            1 .. invert the selected GPIO            0 .. pass the selected GPIO unchanged            Note that the edge detector detects either rising edge or both. The mode is selectable by EDGE_INT1 bit is separate register.</p>
6:4	sel_int1[6:4]	<p><b>Port bit selector for INT1.</b>            The decimal representation of this field selects the following GPIO[N]:            0-4 .. GPIO[0-4]            5 .. GPIO[9]            6-7 .. GPIO[6-7]</p>
3	neg_int0	<p><b>Negative INT0 polarity.</b>            This bit selects whether the selected INT0 GPIO input will get inverted or pass as is before going to the edge detector.            1 .. invert the selected GPIO            0 .. pass the selected GPIO unchanged            Note that the edge detector detects either rising edge or both. The mode is selectable by EDGE_INT0 bit is separate register.</p>
2:0	sel_int0[2:0]	<p><b>Port bit selector for INT0.</b>            The decimal representation of this field selects the following GPIO[N]:            0-4 .. GPIO[0-4]            5 .. GPIO[8]            6-7 .. GPIO[6-7]</p>

---

---

## SFR Definition 18.8. PORT\_SET

---

Bit	7	6	5	4	3	2	1	0
Name	edge_int1	edge_int0	port_clkout		port_clken	port_refen	port_sermode	port_seren
Type	R/W	R/W	R/W	R/W	R/W	R/W	R/W	R/W
Reset	0	0	0	0	0	0	0	0

SFR Address = 0xB6

# Si4010-C2

Bit	Name	Function
7	edge_int1	<p><b>Edge control for INT1.</b> This bit controls whether single edge or both edges invoke the interrupt.</p> <p>0 .. single edge, polarity specified by NE_INT1 in PORT_INTCFG 1 .. both edges, which means any edge, invoke INT1 interrupt</p>
6	edge_int0	<p><b>Edge control for INT0.</b> This bit controls whether single edge or both edges invoke the interrupt.</p> <p>0 .. single edge, polarity specified by NEG_INT0 in PORT_INTCFG 1 .. both edges, which means any edge, invoke INT0 interrupt</p>
5:4	port_clkout	<p><b>Select what GPIO pin as clock output pin:</b> port_clkout[0] .. GPIO[4]: 1 .. clk output, 0 .. normal operation port_clkout[1] .. GPIO[6]: 1 .. clk output, 0 .. normal operation</p> <p>Both outputs can be used simultaneously. The actual clock waveform can be enabled/disabled by porc_clken bit, but the GPIO configuration is purely controlled by port_clkout. If the port_clkout bit is set it takes precedence over both normal port operation and SPI/I2C operations. It has highest priority.</p>
3	port_clken	<p><b>Enable output clock, which is possibly coming out on GPIO[4] and/or GPIO[6].</b> This bit is just a clock enable/disable, it does not configure the GPIO for clock outputs. The port configuration must be done by port_clkout below. The generated clock division is controlled by CLKOUT_SET register. If the clock is disabled by PORT_CLKEN=0 the current period in progress will be finished and the output clock will stop as logic 0.</p>
2	port_refen	<p><b>Enable clk_ref reference clock to come from GPIO[3].</b> The GPIO[3] pad is forced to be an input. There is not need to change p0 or p0con register values, since port_refen has higher priority. The port_refen has higher priority than SPI, so if the SPI is selected, it is bypassed by port_refen, which takes precedence.</p>
1	port_sermode	<p><b>Serial communication mode.</b> If port_seren=0 then setting of this bit has no effect. It only takes effect if port_seren=1. The selection values: 0 .. SPI .. GPIO[3:0] are used. 1 .. I2C .. GPIO[2:1] are used.</p> <p>If the SPI is configured in 3 wire mode (see SPI section), then only GPIO[3:1] are used for SPI. Before using I<sup>2</sup>C the port_roff mode must be set and latched to the GPIO pads to disable the pull-up resistors on GPIO[2:1]. There is no need to change values of p0 and p0con registers, since the port_seren has higher priority than ordinary port.</p>
0	port_seren	<p><b>Serial enable mode.</b> Enable some or all GPIO[3:0] for serial communications, which can be either I<sup>2</sup>C or SPI, controlled by the port_sermode.</p>

---

**SFR Definition 18.9. PORT\_TST**

---

Bit	7	6	5	4	3	2	1	0
Name	reserved	port_tst_fs[6:4]			port_tst_ind[3:0]			
Type	R	R/W	R/W	R/W	R/W	R/W	R/W	R/W
Reset	0	0	0	0	0	0	0	0

SFR Address = 0x4017

Bit	Name	Function
7	reserved	<b>Reserved.</b>
6:4	port_tst_fs [6:4]	<b>GPIO test force/sense control.</b> Masked to 0x0 in scan mode in digital.
3:0	port_tst_ind [3:0]	<b>GPIO test pin selection.</b> It is an index to the GPIO[N] as appear on the ports and the package diagram. The reset value must be 4'b1111. Goes through digital, all one hot outputs are forced to 0 in scan mode in digital.

# Si4010-C2

---

---

## SFR Definition 18.10. CLKOUT\_SET

---

Bit	7	6	5	4	3	2	1	0
Name	clkout_cir	clkout_inv	clkout_sym	clkout_div[4:0]				
Type	R/W	R/W	R/W	R/W	R/W	R/W	R/W	R/W
Reset	0	0	0	0	0	0	0	0

SFR Address = 0x8F

Bit	Name	Function
7	clkout_cir	<p>Write 1 to this bit clears the generated clock divider. The generated clock output is forced to 0. The pulse must be aligned with the registered write enable for this register, therefore the generated clear pulse must be registered.</p> <p>Reading this bit has CLKOUT_IDLE meaning. If read as 1 then it indicates that the clock divider generator is idle. It can be used to wait for the clock to get idle after the user clock output was disabled by PORT_SET.PORT_CLKEN=0. If this bit is read as 1 the clock division generator by factor 2 and above is running and the current user clock period is still in progress.</p> <p>The user could use this bit to synchronously switch the CLKOUT_DIV division factor, but it is not necessary. The synchronous clock period switching is built in the hardware. See the CLKOUT_DIV section above. To switch the clocks immediately without waiting for the current period to end, write 1 to this bit. The write 1 to this bit can be combined with setting the new CLKOUT_DIV value in this register at the same time.</p>
6	clkout_inv	<p><b>CLKOUT_INV</b></p> <p>Invert the generation clock. The inverter is at the very end of the clock generation chain. Normally, if this bit is 0, if the generated clock is disabled the output is at 0. With this bit set to 1 the output is inverted, therefore the generated clock stops at 1. This bit must be set before customer clock is enabled to the port output by setting PORT_SET.PORT_CLKEN=1. If changed later the clock inversion takes effect immediately with possibility of short clock pulse being generated at the clock output.</p>
5	clkout_sym	<p><b>CLKOUT_SYM</b></p> <p>If this bit set to 1 then the output clock duty cycle is very close to 1:1 irrespective of the division factor. However, the generated clock waveform is a combination of outputs of two flops and therefore might jitter more. If this bit is 0 then for odd division factor there is a single 25MHz period difference in between halves of the generation output clock.</p> <p>This bit must be set before customer clock is enabled to the port output by setting PORT_SET.PORT_CLKEN=1.</p>
4:0	clkout_div [4:0]	<p><b>CLKOUT_DIV</b></p> <p>Division factor of the 25 MHz oscillator clock for generation of the output customer clock. The enable of the clock is controlled by the PORT_CLKEN and PORT_CLKOUT bits in PORT_SET register. The division factors 0 and 1 pass the 25 MHz internal cheap oscillator output as output clocks. Value bigger than 1 is the actual division factor of the 25 MHz.</p> <p>If CLKOUT_SYM=0 (recommended), the generated clock is an output of a flop. For odd division ratios the first part of the period in logic 0 is one 25 MHz clock cycle shorter than the second high half part of the period of generated clock, assuming CLKOUT_INV=0.</p> <p>If the clock is disabled by PORT_CLKEN=0 the current period in progress will be finished. To monitor when the output gets idle monitor the CLKOUT_CLR bit below.</p> <p>The CLKOUT_DIV bit can be changed any time. The new setting will take effect only after the current period finishes. For the new setting to take effect immediately see CLKOUT_CLR.</p>

**Table 19: port\_led encoding**

Value	Description
0	LED is off
1	0.62 * 600uA current source
2	1.00 * 600uA current source
3	1.62 * 600uA current source

**Table 20: port\_tst\_ind encoding**

Value	Description
0	Select GPIO[0]
1	Select GPIO[1]
2	Select GPIO[2]
3	Select GPIO[3]
4	Select GPIO[4]
5	Select GPIO[5]
6	Select GPIO[6]
7	Select GPIO[7]
8	Select GPIO[8]
9	Select GPIO[9]

**Table 21: port\_tst\_fs encoding**

Value	Description
0	No connect
1	Sense selected pin on atbs<0> with pullup resistor disabled
2	Force selected pin with pullup resistor disabled
3	Force and sense selected pin with pullup resistor disabled
4	Enable power hungry "accurate mode" slicer, and select output to gpio_interval signal. Used for capacitive sensing; pullup resistor enabled. NOTE: GPIO[0] does not have an accurate mode. If the pad goes to accurate mode then the value to digital will be forced to 0 immediately upon entering the accurate mode irrespective of the GPIO[0] input pad value.
5	Sense selected pin on atbs<0>, and next pin "up" on atbs<1> Allows digitization of differential input voltages Pull up resistors on both pins are disabled.



Table 21: port\_tst\_fs encoding

Value	Description
6	Force selected pin (and pullup resistor)
7	Force and sense (on atbs<0>) selected pin, pullup resistor enabled

18.0.4. GPIO Schematic Diagram

The following figure shows the functional diagram of GPIO and the related digital control.

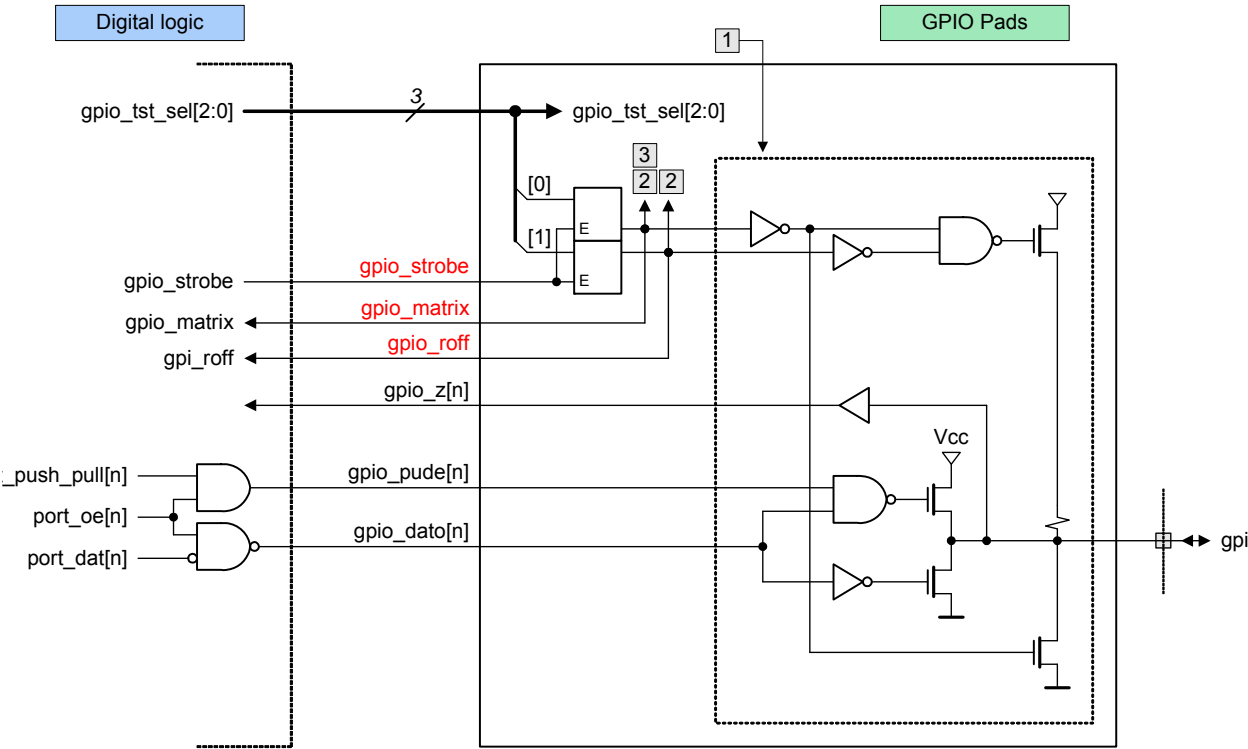

Figure 18.1. GPIO Functional Diagram

# Si4010-C2

## 18.0.5. GPIO Pin Special Roles

The assignments in Table 22 represent a plan, some of which is software configurable, and some uses special hardware. The hardware associated pieces are hard-wired on bench loadboard, associated with the first 4 columns below:

**Table 22: GPIO Special Roles**

GPIO Number	Other Special Roles	C2	FOB	Can Drive Low During Sleep	Pullup Roff Option	Scan	Freq Counting	I2C	SPI
0	XO/6.5V		button			scan_in[0]			NSS <sup>a</sup>
1			button	Y	Y	scan_in[1]		SDA <sup>b</sup>	MOSI
2	clk_sys in <sup>c</sup>		button	Y	Y	scan_out[0]		SCL	SCLK
3			button	Y		scan_out[1]	clk_ref		MISO
4	clk_sys out	C2DAT	button			scan_en			
5	clk_sys in <sup>d</sup>	C2CLK	LED <sup>e</sup>			scan_clk			
6 (14 pin only)	clk_sys out <sup>f</sup>		button						
7 (14 pin only)			button						
8 (14 pin only)			button						
9 (14 pin only)			button						

- a. Optional, not needed for simple 2 point SPI connections.
- b. Open collector drive mode.
- c. Optional, for tester use only. Independent external clock.
- d. Optional, for tester use only. Controlled by C2 native registers, the MCU clock divider is disabled. The C2DAT pin is fully taken by C2 and C2 transaction starts with input start bit being 1. C2DAT must be held 0 in between C2 transactions.
- e. Current mode drive for LED connected to supply.
- f. Optional clk\_sys output can be set on GPIO[4] or GPIO[6], or both at the same time.

## 18.0.6. Scan Setting

GPIO must be set to proper values before going to scan mode. The following setting must be done prior to scan mode:

Master must latch in values through the test bus such that **gpio\_matrix=0** and **gpio\_roff=1**.

Scan control logic has to configure the ports such that the outputs are configured in push-pull mode and the ports which has to be input are configured to have their driver in Hi-Z.

LED driver and other speciality features must be disabled in combination by internal signal **scan\_mode=1**

The only way to leave scan mode is to cycle the chip power.

## 19. Temperature Sensor

Decimation involves producing a single output every 256 clock cycles, which is the result of convolving the one bit digital input with a  $\text{sinc}^3$  filter. One approach for the implementation is outlined below. While 3 integrators and 3 up/down counters are illustrated, an area-efficient (and less noisy) approach with equivalent functionality may involve using just 1 or just 2 adders, using multiple higher speed clock cycles to run the operations.

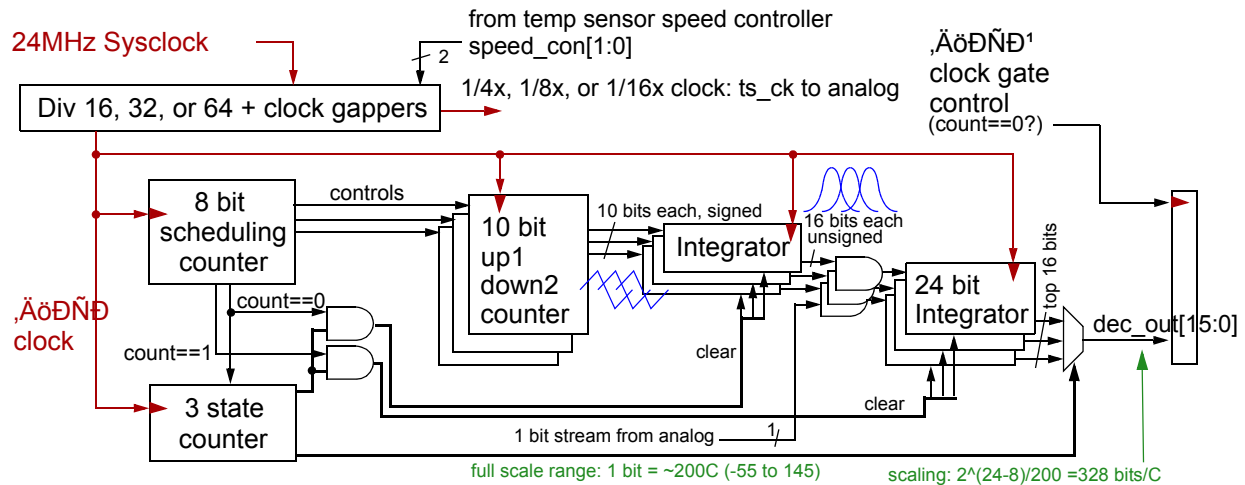

**Figure 19.1. Temperature  $\Delta\Sigma$  Decimator**

Note that both the tap weights and outputs are unsigned.

Note that on ts\_ena de-assertion, all state information (counter phase, integrator contents, register) is cleared.

# Si4010-C2

---

## 19.0.1. Register Interface for Temperate Sensor Demodulator

---

### SFR Definition 19.1. DMD\_CTRL

---

Bit	7	6	5	4	3	2	1	0
Name	ts_ena	dmd_ena	dmd_tclk_ena[5:4]		dmd_new	dmd_clear	dmd_speed[1:0]	
Type	R/W	R/W	R/W	R/W	R/W	R/W	R/W	R/W
Reset	0	0	0	0	0	0	0	0

SFR Address = 0x0E5

Bit	Name	Function
7	ts_ena	<p><b>Enable the temperature sensor.</b></p> <p>This signal controls the analog circuitry directly. It must be inverted to form analog control signal ts_dis. Note that the bandgap must be enabled prior to enabling the temperature sensor. Startup time is 10us for the regulator to ramp up + 40 temperature sensor clock cycles for the input and output common modes of the integrating amplifiers to settle. For example, if the input clock to the temperature sensor is 6.25MHz, the fastest clock rate, then startup time is 16.4us:</p> $T_{startup} = 10\mu s + 40 * 160ns$
6	dmd_ena	<p><b>Demodulator enable.</b></p> <p>If disabled the demodulator is not running and clock to the demodulator is partly shut down. Even if the DMD is not enabled, the TS clock can still be generated. To completely disable clock to the demodulator set dmd_ena=0 and dmd_tclk_ena=2'b00 at the same time.</p>
5:4	dmd_tclk_ena[5:4]	<p><b>Enable temperature sensor clock generation.</b></p> <p>The demodulator generates temperature sensor (TS) clock independent of the ts_ena and dmd_ena bit settings.</p> <p>00 .. disable TS clock generation  01 .. synchronize for falling TS clock edge prior sample  10 .. synchronize for rising TS clock edge prior sample  11 .. free running TS clock</p> <p>Recommended setting is 10 for regular operation. If the clock is disabled it always stops at value 0.</p>
3	dmd_new	<p><b>New output sample is ready at dmd_data output.</b></p> <p>This bit is a DMD interrupt flag. If the DMD interrupt is enabled then when this bit is 1 the DMD interrupt gets generated. This bit must be cleared by software prior to leaving DMD interrupt service routine. It is not cleared by hardware. The bit logic is implemented in the interrupt controller.</p>
2	dmd_clear	<p><b>Write only.</b></p> <p>Writing 1 resets the sigma delta demodulator of the temperature sensor. First new output is produced ~256 cycles after this reset. Third new output is first valid output. The internal state machines gets cleared as well as data path. Writing 0 has no effect. Clearing will take place at the beginning of the write event.</p>
1:0	dmd_speed [1:0]	<p><b>Selects speed of temperature sensor clocking.</b></p> <p>00 .. clk_sys/8 bit rate == clk_sys/4 TS clock, fastest.  01 .. clk_sys/16  10 .. clk_sys/32  11 .. clk_sys/64</p>

**Table 23: dmd\_speed encoding**

Value	Description
0	Bit rate is 1/8 of clk_sys, TS clock is 1/4 clk_sys.
1	Bit rate is 1/16 of clk_sys, TS clock is 1/8 clk_sys.
2	Bit rate is 1/32 of clk_sys, TS clock is 1/16 clk_sys.
3	Bit rate is 1/64 of clk_sys, TS clock is 1/32 clk_sys.

## 20. Bandgap (Combine with LDO and POR?)

The Si4010 includes a low-drop-out (LDO) regulator with a power-on reset (POR) circuit.

??? Register BAND\_CTRL.BAND\_ENA bit???

## 21. OTP Memory

See Kilopass documentation.

- Specification
- Product test flow

### 21.0.1. Register Interface

NVM is directly accessed by registers in Memory Controller (MC). See the MC section for register relevant to NVM.

## 22. Packet Serializer

### 22.0.1. Description

The serializer accomplishes these functions:

- Controls the edge rate of the PA on/off transitions.
- Schedules PA, MPLL, LCOsc on/off power transitions for JIT operation, minimal wasted power.
- Controls the serial data rate.
- Provides handshake interface and a 1 byte pipeline to allow a software process to maintain steady dataflow.
- Modulates a 7 bit “frequency deviation” bus to the LC oscillator to allow for FSK operation.
- Provides test features allowing forcing (to “on”) the power state of the LCOsc, MPLL, and PA; recirculating a fixed pattern; forcing the FSK offset frequency.

### 22.0.2. Timing

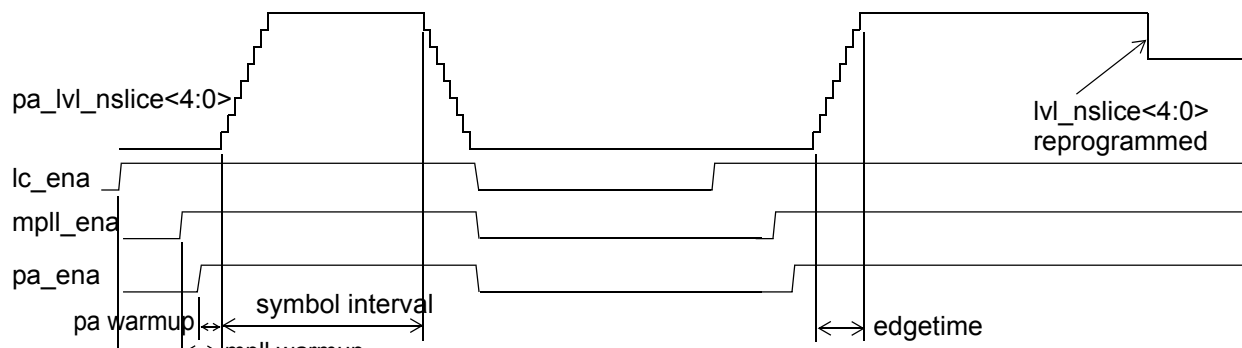

Figure 22.1. OOK Timing Example

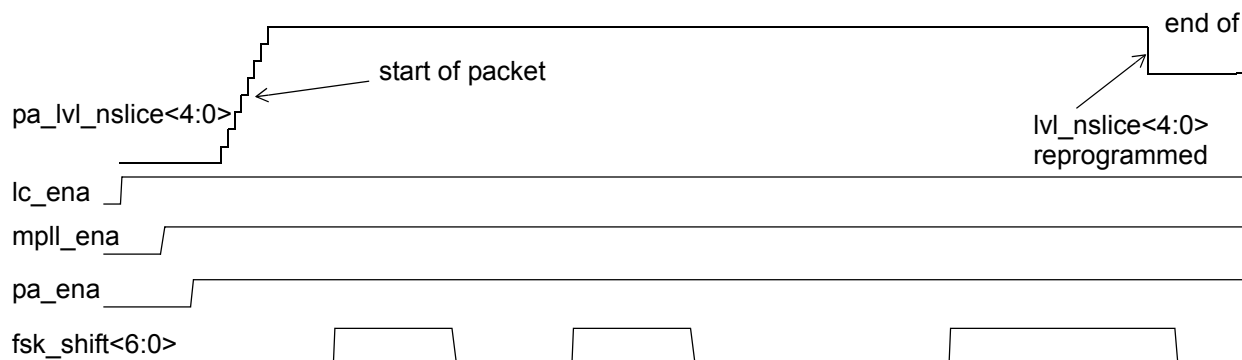

Figure 22.2. FSK Timing Example

### 22.0.3. Serializer is “Little-Endian” and Right Justified

Data from the *ods\_data* register is loaded into the serializer’s shift register and shifted out, bit 0 first.

When *ods\_group\_width* is < 7, the logical symbol width is less than a full byte. In this case, the lsb is still shifted out first, and one or more of the MSBs are not shifted out at all.

# Si4010-C2

## 22.0.4. Register Description

Note that an update is needed to def of ods\_warm\_lc. Warm-up interval is 2x as long as indicated here, with max programmable value from 60-160us, depending on ods\_ck\_div setting.

### SFR Definition 22.1. ODS\_CTRL

Bit	7	6	5	4	3	2	1	0
<b>Name</b>	ods_shift_ctrl[7:6]		fsk_force_dev	fsk_mode	force_lc	force_mpll	force_pa	ods_en
<b>Type</b>	R/W	R/W	R/W	R/W	R/W	R/W	R/W	R/W
<b>Reset</b>	0	0	0	0	0	0	0	0

SFR Address = 0xA9

Bit	Name	Function
7:6	ods_shift_ctrl[7:6]	<b>ODS_SHIFT_CTRL</b> Controls behavior of serializer when it is allowed to run out of data.
5	fsk_force_dev	<b>FSK_FORCE_DEV</b> When 1 then fsk_dev_2lc<6:0> (signal controlling actual lcosc frequency) is set to FSK_DEVIATION[6:0] value in LC_FSK register, unconditionally regardless of data pattern or FSK_MODE, etc.
4	fsk_mode	<b>FSK_MODE</b> When 1 then FSK transmission is selected. Otherwise OOK.
3	force_lc	<b>FORCE_LC</b> When 1 then the serializer asserts lc_ena, unconditionally.
2	force_mpll	<b>FORCE_MPLL</b> When 1 the serializer asserts mppll_ena, unconditionally.
1	force_pa	<b>FORCE_PA</b> When 1 then the serializer asserts pa_ena, unconditionally. In addition, PA_LVL_NSLICE[4:0] in PA_LVL register is passed directly through the serializer, unchanged.
0	ods_en	<b>Enable the serializer.</b>



**SFR Definition 22.2. ODS\_TIMING**

Bit	7	6	5	4	3	2	1	0
Name	ods_group_width[7:5]			ods_edge_time[4:3]		ods_ck_div[2:0]		
Type	R/W	R/W	R/W	R/W	R/W	R/W	R/W	R/W
Reset	0	0	0	0	0	0	0	0

SFR Address = 0xAA

Bit	Name	Function
7:5	ods_group_width[7:5]	<b>Controls symbol group width, from 2-8 symbols.</b> For example, set to 4 to transmit 5 symbol groups obtained from 4/5 encoding. Or set to 7 to sample 8 symbol group obtained from Manchester encoding of 4 bits. Note that ser_group_width can be changed dynamically prior to writing the ODS_DATA register, should you want to (for example) add 2 more symbols to the end of a transmission which was previously using 8 symbol groups.
4:3	ods_edge_time[4:3]	<b>Additional division factor in range 1-4 (ser_edgetime+1).</b> PA controlled edge rates are: $8 * (ods\_ck\_div + 1) * (ser\_edgetime + 1) / 25$ MHz When clk_ods is in range of 3-8 MHz, edge rate can be selected from 1us to 10.7us. Study has indicated that in the worst case (20Kbps Manchester), edge rates somewhat higher than 4us are needed.
2:0	ods_ck_div [2:0]	Control first 25MHz clock divider to produce slower clk_ods. Division factors are 1-8 (ods_ck_div+1). Generally should select factor which produces serializer clock in range of ~ 3-8 MHz

**SFR Definition 22.3. ODS\_DATA**

Bit	7	6	5	4	3	2	1	0
Name	ods_data[7:0]							
Type	R/W	R/W	R/W	R/W	R/W	R/W	R/W	R/W
Reset	0	0	0	0	0	0	0	0

SFR Address = 0xAB

Bit	Name	Function
7:0	ods_data [7:0]	<b>Symbol group register.</b> Side effect of writing is clearing of ODS_EMPTY flag. It generates a single pulse for the ODS to notify it that the Tx ODS data SFR holding register been written to and contains new data. The pulse is a registered write pulse, so it will be generated when the data is stable in the holding register.

# Si4010-C2

## SFR Definition 22.4. ODS\_RATEL

Bit	7	6	5	4	3	2	1	0
Name	ods_ratel[7:0]							
Type	R/W	R/W	R/W	R/W	R/W	R/W	R/W	R/W
Reset	0	0	0	0	0	0	0	0

SFR Address = 0xAC

Bit	Name	Function
7:0	ods_ratel [7:0]	<p><b>Bottom byte of the 15-bit wide data rate field.</b>            Bottom byte of the 15 bit wide data rate field. Symbol rate produced by the serializer is <math>25e6 / (\text{ser\_datarate} * (\text{ods\_ck\_div} + 1))</math>            When clk_ods is in the range of 3-8 MHz:</p> <ul style="list-style-type: none"> <li>■ lowest achievable data rate is 91.55 symbols/sec</li> <li>■ highest achievable data rate while maintaining 1% resolution is 80Kbps</li> </ul>

## SFR Definition 22.5. ODS\_RATEH

Bit	7	6	5	4	3	2	1	0
Name	ods_unused	ods_rateh[6:0]						
Type	R	R/W	R/W	R/W	R/W	R/W	R/W	R/W
Reset	0	0	0	0	0	0	0	0

SFR Address = 0xAD

Bit	Name	Function
7	ods_unused	<p><b>Reserved.</b>            Read as 0. Write has no effect.</p>
6:0	ods_rateh [6:0]	<p><b>Upper bits of 15-bit ODS data rate field.</b>            See the ODS_RATEL for description of the serializer data rates.</p>

**SFR Definition 22.6. ODS\_WARM1**

Bit	7	6	5	4	3	2	1	0
Name	ods_warm_pll[7:4]				ods_warm_pa[3:0]			
Type	R/W	R/W	R/W	R/W	R/W	R/W	R/W	R/W
Reset	0	0	0	0	0	0	0	0

SFR Address = 0xAE

Bit	Name	Function
7:4	ods_warm_pll[7:4]	Sets the "warm up" interval for the MPLL, where it is biased up prior to transmission or on the transition from OOK Zero bit to OOK One bit. Interval is in $4 * \text{clk\_ods}$ cycles resolution Interval = $4 * \text{ser\_warm\_pa} * (\text{ods\_ck\_div} + 1) / 25 \text{ MHz}$ When $\text{clk\_ods}$ is in range of 3-8 MHz, max setting is from 7.6 to 20 us
3:0	ods_warm_pa[3:0]	Sets the "warm up" interval for the PA, where it is biased up prior to transmission or on the transition from OOK Zero bit to OOK One bit. Interval is directly in $\text{clk\_ods}$ cycles Interval = $\text{ser\_warm\_pa} * (\text{ods\_ck\_div} + 1) / 25 \text{ MHz}$ When $\text{clk\_ods}$ is in range of 3-8MHz, max setting is from 1.9 to 5 us

**SFR Definition 22.7. ODS\_WARM2**

Bit	7	6	5	4	3	2	1	0
Name	ods_unused[7:4]				ods_warm_lc[3:0]			
Type	R				R/W			
Reset	0	0	0	0	0	0	0	0

SFR Address = 0xAF

Bit	Name	Function
7:4	ods_unused[7:4]	<b>Reserved.</b> Read as 0x0. Write has no effect.
3:0	ods_warm_lc[3:0]	Sets the "warm up" interval for the LC oscillator, where it is biased up prior to transmission or on the transition from OOK Zero bit to OOK One bit. Interval is in $64 * \text{clk\_ods}$ cycles resolution Interval = $64 * \text{ser\_warm\_pa} * (\text{ods\_ck\_div} + 1) / 25 \text{ MHz}$ When $\text{clk\_ods}$ is in range of 3-8 MHz, max setting is from 30 to 80 us

I

**Table 24: ods\_shift\_ctrl encoding**

<b>Value</b>	<b>Description</b>
0	Gracefully end last bit and shut down PA, MPLL, LCosc. OOK or FSK mode, works the same.
1	Keep reusing the last symbol group
2	All 0s
3	All 1s

---

## 23. Digital part of the chip

The following structure of modules constitutes digital part of the chip:

- **dig\_route** .. digital top (maybe it will be called **dig\_top**)

MCU related modules, existing and new

- **cpu** .. CPU core
- **intc** .. interrupt controller
- **tmr** .. timers 2 and 3
- **ser** .. serial interface, I2C and SPI, active only one at a time
- **mc** .. memory controller
- **bootc** .. boot controller and memory protection
- **portc** .. port controller. Controls the GPIO's
- **rstc** .. reset controller and reset generator
- **clkc** .. clock controller. Controls division and muxing of the two input clocks, scan clock, etc.
- **c2** .. C2 interface with fast path to SFR and scan control switch logic
- **xsfr** .. synchronization layer in between C2 and SFR registers with fast path modifications
- **emu** .. breakpoints and patch address points with DSR supporting logic for on chip debugging
- **mtp** .. instance of the MTP Virage (Impinj) memory
- **rtc** .. real time clock timer
- **sfreg** .. SFR registers for analog and distributed address decoding for legacy or distributed SFR registers. Replacement for `cisl_8051` module on other chips.
- **xreg** .. test and NVM registers sitting in the XDATA memory space

Si500 reused or modified modules

- **htrc** .. heater controller. Only output modulator logic gets reused.
- **fcount** .. frequency counter. Must be modified for new modes.
- **modulator** .. modulator for LC oscillator. Can be reused as is.
- **tsr\_dmd** .. temperature sensor demodulator. Must be heavily modified.
- **global** .. buffers, common clock gating cells, synchronizers, common settings, Verilog defines

Si6110 new modules

- **ods** .. output data serializer
- **aes** .. AES hardware accelerator logic
- **non\_scan** .. logic related to actual scan mode, which must not be scanned
- **digm** .. digital analog input wrappers and digital miscellaneous logic at `dig_route`. Could be called glue.

## 23.1. Summary of Registers

There are two register regions on chip:

- SFR region .. SFR address space .. register type `sfreg`, field type `sfr`.
- XREG region .. XDATA address space .. register type `xreg`, field types `nvm` (packed) and `test` (regular)

### 23.1.1. SFR Registers

The SFR registers are both centralized in the `sfreg` module and distributed through the design, residing in their respective modules. The `sfreg` module serves as an implementation module of centralized registers and as an address decoder and read mux for distributed ones.

In register description files the register type is `sfreg`, and the field **Type**, as it appears in tables in this document, is `sfr`. The address of SFR registers must be selected manually. The address map of SFR registers is in the table below.

By convention, the register names are capitalized as they appear in software header. They are lower case in the register description tables through this document.

### 23.1.2. XREG Registers

The chip contains another set of registers implemented in `xreg` module. These registers are mapped are a regular external memory in XDATA address space, addressable by MOVX instructions only. From CPU perspective it is a regular external memory. Make sure that all the registers are declared as **volatile** in C headers.

In register description files the register type is `xreg`, and there are two field **Type**-s associated with `xreg` register type:

- `nvm` .. field which is a trim values to be stored in the packed region of NVM. This field type has an additional packed view additional address space in XREG registers for this type of field, so each of the field can be read and written by two ways: As a part of regular register and as a part of the packed region. This is to save NVM area and ease the software trim load.
- `test` .. regular register. For the lack of the term the field type `test` was used, but those registers are regular registers. Since it is desirable to put most registers into SFR space, these registers are mostly for test purposes, since they are further away from the CPU then the SFR ones.

The address of XREG registers can be both automatically generated (preferred) and selected manually for particular special registers if needs be.

The advantage of the XREG registers is that they are viewed by CPU as a regular memory. Therefore, they can be declared as different data types, structures, array of bytes, and so on. With SFR we are stuck with special registers and it is not possible to declare them as long integers, for example. On the other hand the SFR register access is faster and one can use arithmetic and logical operations on them.

Note that registers in the XREG regions are aligned at 8, 16, and 32 bit boundaries and they are stored in **big** endian fashion. This is to support Keil C compiler, which uses **big endian**. Note that if the register is, say 23 bits wide, the 32 bits (4 bytes) are allocated for the register and the register is aligned in big endian fashion.

Therefore, the LSB byte of the register will be at the address `<reg_addr> + 3`, while the byte directly at the `<reg_addr>` is the MSB byte and is empty (read as 0x0), since the register itself is only 23 bits wide.

The `nvm` type packed region address and size is in the following table. The name of the register is `<reg_type>_<field_type>_pack`. It is declared as array of bytes for software, aligned as **little** endian:

## USB Register Definition 23.1. C2 Interface - c2

C2 interface is a serial interface with bidirectional C2CLK and bidirectional C2DAT. The C2CLK should be a dedicated pin, while C2DAT will be stolen from the application when the C2 transaction begins.

C2 will interface with **xsfr** and **emu** modules to enable synchronous communication with SFR registers while the CPU is running.

### 23.1.3. C2CLK and LED Driver Sharing

The C2CLK is shared with LED driver current output. If the LED driver is active, it is not possible to use C2 interface. The LED output data path must be block in the following scenarios:

When use sets **led\_dis** to disable LED driver for software development purposes.

When the DSR routine is active and is not serving a patch but an actual breakpoint. SW will have to disable the LED and therefore enable the C2.

The C2CLK is sourced as a system clock using **c2\_set\_xclk** C2 native register bit.

In **scan\_mode** when C2CLK is used as scan clock.

If LED driver is active then C2 interface state machine will be held in reset by **rst\_c2\_fsm** internal signal, so there will be no issue when the LED driver is released. If released, the C2 will get released from reset, if the C2 is enabled.

### 23.1.4. Register Description

C2 address and status special address register.

**Table 25: Register description: C2 control**

Register	Addr	Field	Bits	Bas	Prop	Rst	Type	Description
c2_ctrl	0x3	c2_fp_wr_en	1	0	rw	0	c2	<p>Enable fast path (FP) for SFR writes. When this bit is set then all the C2 writes to the C2 address equal or above 0x80, which is CPU SFR region, would look like to the C2 as if they went to the native C2 registers in C2CLK domain. Therefore, the C2 protocol wait cycles biderctional handshake is not present and the C2 write C2DAT waveform looks like the wavefor for writing to the C2 native registers.</p> <p>WARNING: Use this mode at your own risk. This mode can be used only when the master knows what is the CPU clock frequency. The previous SFR fast path write must finish before a new FP SFR write appears. It takes at most 6 clk_sys CPU cycles for the FP SFR write to finish. Therefore, if the C2CLK and CPU clock are about 25MHz both, we can push FP SFR writes to the chip back to back. If the new FP SFR write appears before the old one finished the write result of both bytes is not guaranteed. This mode is for tester code only!</p>

**Table 25: Register description: C2 control**

Register	Addr	Field	Bits	Bas	Prop	Rst	Type	Description
		c2_fp_rd_en	1	1	rw	0	c2	<p>Enable fast path for SFR reads. When this bit is set then all the C2 reads from the the C2 address equal or above 0x80, which is CPU SFR region, would look like to the C2 as if the master read from the native C2 registers in C2CLK domain.</p> <p>However, there is and IMPORTANT distinction in between the fast path write and fast path reads. While the FP write is truly the same as native C2 register write, the FP read from SFR registers requires a special C2CLK waveform with a particular period of the C2CLK extended to at least 6 clk_sys cycles. See the description in the C2 section of the specification. This mode is for tester code only!</p>
		c2_cpu_dis_asy nc	1	2	rw	0	c2	<p>CPU user disable type.</p> <p>0 .. synchronous (possibly delayed) 1 .. asynchronous (immediate)</p> <p>See the C2_CPU_DIS in C2_DEBUG register for explanation. The default should be synchronous unless there is a problem with digital. If synchronous user disable works as expected then we can easily communicate with all the memories on chip through memory controller (MC) by just synchronously stopping the CPU any time.</p>
		c2_ack_dis	1	3	rw	0	c2	<p>Disable generation of C2ACK on the C2CLK pin. Since the C2CLK pin is shared as a LED driver output, it might not be reliable to use that pin to communicate with the master. In original C2 interface used by MCU group the C2CLK is a bidirectional pin. Whenever the DBI debug interrupt is invoked by and internal CPU breakpoint, the DSR routine issues a request for turning the C2CLK pin as output and forcing it to logic 0 for at least 1us to signal to the debugging master device that CPU got halted by and internal breakpoint.</p> <p>Alternative to this is a continuous polling of a native C2 register by the master to get a status of the device.</p> <p>If this bit is set the C2CLK toggle to logic 0 is disabled and the DSR routine gets an immediate acknowledge that this pulse happened, since it needs it to proceed.</p>
		c2_led_dis	1	4	rw	0	c2	<p>Disable the LED driver to drive the C2CLK. When this bit is set then only writing it back to 0 or power on reset will clear the bit. The bit will not get cleared otherwise and LED would stay disabled. This bit is needed for ease of integration of the IDE with this chip.</p>



Table 25: Register description: C2 control

Register	Addr	Field	Bits	Bas	Prop	Rst	Type	Description
		c2_fp_busy	1	5	r	0	c2	Fast path request active. This read only bit is for mostly for diagnostic purposes. If the fast path SFR write or read request was issued this bit reflects whether the fast path logic is idle (0) or busy servicing the FP request (1).
		c2_unused	2	6	r,doc	0x0	c2	Reserved. Read as 0x0. Write has no effect.

Table 26: Register description: C2 test mux

Register	Addr	Field	Bits	Bas	Prop	Rst	Type	Description
c2_test	0x6	c2_test_sel	5	0	rw	0x0	c2	Digital test mux selection. Higher priority then the TEST_SEL selector controlled from CPU. If the value is 0x0, then the test mux is not selected. Then the CPU TEST_SEL can be used to select test mux output. The test mux output is GPIO[1]. When either of the selectors is not zero then the GPIO[1] is automatically configured as output.  If both C2_TEST_SEL=0 and TEST_SEL=0 then the test mux is completely turned off and the GPIO[1] is controlled by the user software using the last configuration setting before C2 or CPU test mux activation.  See the TEST_SEL field description in TEST_MUX register for signal selection table.
		c2_unused	3	4	r,doc	0x0	c2	Reserved. Read as 0x0. Write has no effect.

Table 27: Register description: C2 native Rd/Wr fast path

Register	Addr	Field	Bits	Bas	Prop	Rst	Type	Description
c2_fp_sys_stat	0x6f	sys_stat	8	0	rw,doc	0x0	c2	System status SYS_STAT register. Same as C2_SYS_STAT.  All registers in this section are native fast past write and are also directly mapped into the C2 native address space for native (not fast path) read. Therefore, reading these is a true C2 native register read without the need of special extended C2CLK waveform.
c2_fp_mc_cmd	0x53	mc_cmd	8	0	rw,doc	0x0	c2	Memory controller command MC_CMD register.
c2_fp_mc_ctrl	0x54	mc_ctrl	8	0	rw,doc	0x0	c2	Memory controller control MC_CTRL register.
c2_fp_mc_rdata	0x56	mc_rdata	8	0	rw,doc	0x0	c2	Memory controller read data MC_RDATA register.
c2_fp_gpr_ctrl	0x31	gpr_ctrl	8	0	rw,doc	0x0	c2	General purpose control GPR_CTRL register. Bits [7:6] are also connected to bits [7:0] of address register.

# Si4010-C2

**Table 27: Register description: C2 native Rd/Wr fast path**

Register	Addr	Field	Bits	Bas	Prop	Rst	Type	Description
c2_fp_gpr_data	0x32	gpr_data	8	0	rw,doc	0x0	c2	General purpose data GPR_DATA register.
c2_boot_flags	0x5d	boot_flags	8	0	rw,doc	0x0	c2	Boot flags. See the BOOT_FLAGS register. However, if the C2 was not enabled during boot then this register reads as 0x00.

Ble ble

## Port Controller - portc

Port controller, **portc**, is an interface in between the GPIO analog block and the digital logic. The GPIO ports will occupy P0 and P1 locations in the standard 8052 architecture SFR location with identical control.

However, as shown in Figure , the port controller is also responsible for controlling the state of the pads depending on the state of the CPU. It will work in conduction with C2 interface and DSR routine to forcefully disable the LED driver to enable C2 to operate.

See the GPIO section for digital control.

## Reset Controller - rstc

There is a single asynchronous reset input from analog, **reset**, active high. It will force all internal digital resets to be asserted asynchronously. When the **reset** is released, it is synchronized into the **clk\_sys** clock domain and released synchronously internally. There are several internal resets, which are generated from the input **reset** signal and are also controlled by other internal registers, primarily C2 native registers, to allow selective resets for different part of the design. The figure below shows the internal reset flow schematically:

reset .. from analog

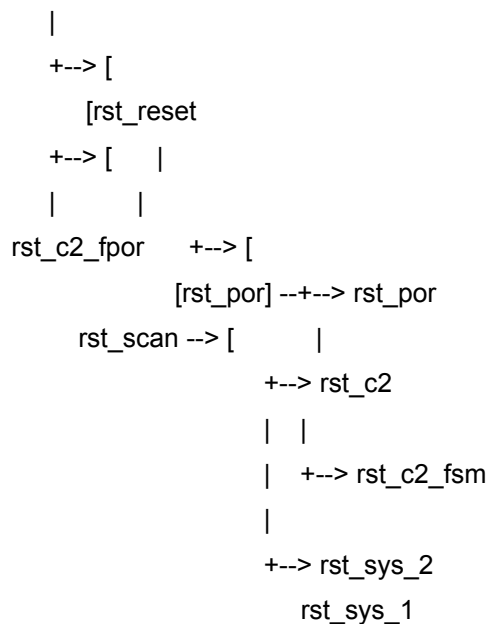

```
rst_sys_0
|
+--> rst_mcu
|
+--> rst_cpu
```

The table describes the different types for resets and the flow in detail. All resets name are assumed to be active high, even though internally the `_n` suffix will be added to those active low.

# Si4010-C2

**Table 28: Digital Resets**

Reset name	Source	Scan value	Description
reset	Analog	--	Main and only asynchronous power on reset from analog.
rst_reset	reset + rst_c2_fpor_r (C2)	--	Raw synchronized POR analog reset from above with short negative pulse deglitching at its output as in Si500. This reset is also a scan mode control reset, raw synchronized POR analog reset from above, same signal as <b>rst_reset</b> . This is scan control reset, clearing the scan related flops, which are not on scan chain. The c2_scan_mode flop MUST NOT BE ON SCAN CHAIN! There will be clock switching logic as well, so all related scan mode flops must not be on scan chain.
rst_scan	rst_reset	scan_en controlled	Internally generated scan reset from 3 flops, gated by scan_in signal. Same trick as on Si500.
rst_por	rst_reset	rst_scan	Synchronized <b>rst_reset</b> with muxing the <b>rst_scan</b> in scan mode. It will feed other resets and reset special flops requiring only POR reset. The <b>clk_sys</b> will always be running when the reset=1-->0 No need to wire async reset to digital blocks.  This signals is the rst_debug signal for C2 and EMU. For EMU to keep the patch values and breakpoints intact during <b>rst_sys</b> system reset. Same signal as <b>rst_por</b> .
rst_c2	rst_por + (c2_off_r + c2_ena_r) (SFR)	rst_scan	C2 only. Same as rst_debug, but also controlled and by two SFR control flops set during boot time. If C2 is disabled it will be held in reset.
rst_c2_fsm	rst_c2 + c2_rst_fsm_r (internal logic)	rst_scan	Reset only the C2 control FSM. Internally generated and needed when LED driver is on. C2 FSM will be held in reset while other C2 native registers will not get affected.
rst_cpu	rst_mcu + (c2_rst_cpu_r (C2) & ~dbi_active)	rst_scan	CPU core reset. Only the core, peripherals (like <b>intc</b> , <b>tmr</b> , etc.) are not touched.  Forcing CPU reset alone by C2 must be disabled while in DSR routine (security hole otherwise, since DSR needs to unlock NVM access for CRC calculation).  Release the block with one clock cycle delay from <b>dbi_active</b> to enable <b>intc</b> to release interrupt correctly.
rst_mcu	rst_sys + c2_rst_mcu_r (C2)	rst_scan	CPU core reset and MCU all native peripherals reset. The values of the analog control registers will not be touched.
rst_sys	rst_por + c2_rst_sys_r (C2)	rst_scan	Digital system reset. Resets everything digital, including SFR <b>sfreg</b> and <b>xreg</b> registers.

CPU Subsystem - cpu

The CPU core is taken as a combination of 'F340 (umami\_revC) and Si4720 code.

There are several native CPU SFR registers, which occupy the SFR space, but are not accessible by the C2 interface. Those registers are only accessible by using software.

## Register Description

Ble ble

**Table 29: Register description: MCU native SFR registers**

Register	Addr	Field	Bits	Bas	Prop	Rst	Type	Description
sp	0x81	sp	8	0	rw,dng	0x0	sfr	SP stack pointer, no C2 access.
dpl	0x82	dpl	8	0	rw,dng	0x0	sfr	DPL data pointer LSB, no C2 access.
dph	0x83	dph	8	0	rw,dng	0x0	sfr	DPH data pointer MSB, no C2 access.
acc	0xe0	acc	8	0	rw,dng	0x0	sfr	ACC accumulator, bit addressable, no C2 access.
b	0xf0	b	8	0	rw,dng	0x0	sfr	B register, bit addressable, no C2 access.

**Table 30: Register description: MCU PSW status flags**

Register	Addr	Field	Bits	Bas	Prop	Rst	Type	Description
psw	0xd0	psw	8	0	rw,dng	0x0	sfr	PSW program status word, bit addressable, no C2 access.
		p	1	0	rw,doc	0	sfr	Parity flag.  1 .. sum of the eight bit of the accumulator ACC is odd 0 .. sum is even
		f1	1	1	rw,doc	0	sfr	User flag 1. Bit addressable general purpose flag for use under software control.
		ov	1	2	rw,doc	0	sfr	Overflow flag. Set or cleared by the result of ADD, ADDC, SUBB, MUL and DIV instructions.
		rs0	1	3	rw,doc	0	sfr	Register bank select bit 0.
		rs1	1	4	rw,doc	0	sfr	Register bank select bit 1. Register bank select RS1, RS0 use to select R0-R7 registers on the following addresses, [RS1, RS0]:  00 .. 0x00 - 0x07 01 .. 0x08 - 0x0F 10 .. 0x10 - 0x17 11 .. 0x18 - 0x1F
		f0	1	5	rw,doc	0	sfr	User flag 0. Bit addressable general purpose flag for use under software control.
		ac	1	6	rw,doc	0	sfr	Auxiliary carry flag. Set when the last arithmetic operation resulted in carry or borrow from the high order nibble. Cleared to 0 by all other arithmetic operations.
		cy	1	7	rw,doc	0	sfr	Carry flag. Set when the last arithmetic operation resulted in carry or borrow. Cleared to 0 by all other arithmetic operations.

# Si4010-C2

**Table 31: Register description: MCU control**

Register	Addr	Field	Bits	Bas	Prop	Rst	Type	Description
pcon	0x87	pcon	8	0	rw,dng	0x0	sfr	Power control, no C2 access.
		idle	1	0	rw,doc	0	sfr	Idle mode select. Setting this bit puts the CPU core into IDLE mode. This bit will always read as 0. The IDLE mode mean that CPU is not executing any instructions, but timers, interrupts, and all other peripherals are getting clocks and active as normal. Getting out of IDLE mode is possible by issuing EITHER an interrupt OR by activating any reset.
		stop	1	1	rw,doc	0	sfr	Stop mode select. Setting this bit puts the CPU core into IDLE mode. This bit will always read as 0. The STOP mode mean that CPU is not executing any instructions, but timers, interrupts, and all other peripherals are getting clocks and active as normal. Getting out of STOP mode is possible ONLY by activating any reset. No clock stopping for Si6110.
		gf5_0	6	2	rw,doc	0x0	sfr	User flags GF5.. GF0. General purpose flags to be used under software control.

Ble ble

System Settings and Control

Ble ble

Register Description

Ble ble

Ble ble

---

**SFR Definition 23.2. SYS\_SET**

---

Bit	7	6	5	4	3	2	1	0
Name	sys_unused[7:5]			mcu_an	aes_decrypt	lcm_dis	heat_hipow	heat_ena
Type	R	R/W	R/W	R/W	R/W	R/W	R/W	R/W
Reset	0	0	0	0	0	0	0	0

SFR Address = 0xEE

Bit	Name	Function
7:5	sys_unused[7:5]	<b>Reserved.</b> Read as 0x0. Write has no effect.
4	mcu_an	<b>Enable MCU anticipation logic for access to shared XDATA/CODE RAM.</b>  1 .. anticipation logic is enabled 0 .. anticipation disabled, one clk_sys cycle wait introduced for all read accesses to XDATA/CODE RAM.
3	aes_decrypt	<b>AES Decrypt.</b> This bit controls the AES SBox hardware accelerator logic. See SBOX_DATA register.  0 .. SBox is set for encryption 1 .. SBox is set for decryption
2	lcm_dis	<b>LC modulator disable.</b> If set then the clock to the LC sigma delta modulator is disabled.
1	heat_hipow	<b>High Power Heat Operator.</b> If set, the heater operators in high power mode.
0	heat_ena	<b>Enable heater controller.</b> When set then the current heater_power value gets used and the heater is going to be heated with that power. When the heat_en goes from 1 to 0 the heater controller keeps running to gracefully shut down the heating elements to prevent chip damage.

# Si4010-C2

## SFR Definition 23.3. RBIT\_DATA

Bit	7	6	5	4	3	2	1	0
Name	rbit_unused[7:6]		gpi- o_led_driv e	xo_ ckgood	ods_ empty	ods_ nodata	trng_out	pa_ compout
Type	R	R	R	R	R	R	R	R
Reset	0	0	0	0				

SFR Address = 0x99

Bit	Name	Function
7:6	rbit_unused [7:6]	<b>Reserved.</b> Read as 0x0. Write has no effect.
5	gpio_led_ drive	<b>Actual status of the LED drive.</b> If this bit is at 1 then the LED driver is actually on. This is a supplemental bit for DSR purposes. The LED driver is controlled by P0.5 bit and the intensity value in PORT_CTRL register. If the P0.5 bit is read then it returns user LED drive request, which does not reflect the actual LED driver status.
4	xo_ckgood	<b>Crystal oscillator XO output is stable.</b> It takes about 5ms before the XO_ENA is set to 1 and the XO output becoming stable. Once this signal becomes 1 software must wait additional 3ms before it can use the XO output for frequency counting. See the XO_CTRL test register.
3	ods_empty	<b>ODS Tx holding register is empty.</b> Supplementary flag indicating that the output digital serializer (ODS) Tx holding register is empty. It can be used as an indication for software to write a new data byte to ODS_DATA register to transmit. This applies to the Tx holding register only. See ODS_NODATA for the flag related to the actual Tx shift register.
2	ods_nodata	<b>ODS out of data.</b> Supplementary flag that the ODS Tx shift register has run out of data and there is nothing else to transmit.
1	trng_out	<b>Thermal random number generator (RNG) output bit.</b> Note that the temperature sensor must be enabled in order to get an interesting result here.
0	pa_compout	<b>Power amplified (PA) related bit.</b> Output of phase detection PA comparator. When PA is enabled, runs at full clock rate, and is asynchronous to clk_sys. Should be demetastabilized sufficiently by transferring to another register for purposes of getting to CPU.



---

**SFR Definition 23.4. Reg\_CTRL**

---

Bit	7	6	5	4	3	2	1	0
Name	reg_unused[7:5]			xreg_load_mask	reg_unused	reg_nvm_clear	reg_test_clear	reg_sfr_clear
Type	R			R/W	R	R/W	W	W
Reset	0	0	0	1	0	0	0	0

SFR Address = 0x9A

Bit	Name	Function
7:5	reg_unused [7:5]	<b>Reserved.</b> Read as 0x0. Write has no effect.
4	xreg_load_mask	Mask the outputs of selected XREG register to their mask analog values (MA:<value>). This relates to most of the NVM type packed fields, so their outputs will not toggle when the packaged NVM trim value region is being loaded upon startup. It is up to software to clear this bit when everything is loaded. All the trim values will then be applied in parallel. Note that some of the NVM values are not masked.
3	reg_unused	<b>Reserved.</b> Read as 0. Write has no effect.
2	reg_nvm_clear	Clear the NVM type fields for the external registers in XREG module in the XDATA region. Same description as REG_TEST_CLEAR, but for NVM type fields.
1	reg_test_clear	Clear the TEST type fields for the external registers in XREG module in the XDATA region. Write only bit. Writing 1 to this bit generates a single clk_sys cycle pulse to synchronously clear TEST fields of the XREG registers. The clear happens on a next clk_sys cycle after the write.
0	reg_sfr_clear	<b>Clear the SFR centralized registers in SFREG module.</b> Write only bit. Writing 1 to this bit generates a single clk_sys cycle pulse to synchronously clear centrally located SFR registers in SFREG module. The clear happens on a next clk_sys cycle after the write.  Note that the distributed registers declared as rwax or wax types will not be cleared! See the list of cleared registers elsewhere in this document.

# Si4010-C2

---

## SFR Definition 23.5. GPR\_CTRL

---

Bit	7	6	5	4	3	2	1	0
Name	gpr_ctrl[7:0]							
Type	R/W							
Reset	0	0	0	0	0	0	0	0

SFR Address = 0xB1

Bit	Name	Function
7:0	gpr_ctrl[7:0]	<b>General purpose register for test program data handshake control.</b> It is reset by rst_sys system reset as other registers. It could be used as software handshake control register for data communication of the MCU test programs with the engineering board or a tester.

---

## SFR Definition 23.6. GPR\_DATA

---

Bit	7	6	5	4	3	2	1	0
Name	gpr_data[7:0]							
Type	R/W							
Reset	0	0	0	0	0	0	0	0

SFR Address = 0xB2

Bit	Name	Function
7:0	gpr_data [7:0]	<b>General purpose register for test program data.</b> It is reset by rst_sys system reset as other registers. It could be used as software data communication register for data communication of the MCU test programs with the engineering board or a tester.

---

**SFR Definition 23.7. IE**

---

Bit	7	6	5	4	3	2	1	0
Name	ea	eint1	etmr3	eods	ertc	edmd	etmr2	eint0
Type	R/W	R/W	R/W	R/W	R/W	R/W	R/W	R/W
Reset	0	0	0	0	0	0	0	0

SFR Address = 0xA8

Bit	Name	Function
7	ea	<b>Enable all interrupts.</b> This bit globally enables/disables all interrupts. It overrides the individual interrupt mask settings.  0 .. disable all interrupts 1 .. enable each interrupt according to its individual mask setting
6	eint1	<b>INT1 external edge interrupt enable.</b> It is an edge interrupt. The edge can be configured as single posedge, negedge, or both.
5	etmr3	<b>Timer 3 interrupt enable.</b>
4	eods	<b>Output data serializer interrupt enable.</b>
3	ertc	<b>Real time clock interrupt enable.</b>
2	edmd	<b>Demodulator interrupt enable.</b>
1	eint0	<b>Timer 2 interrupt enable.</b>
0	eint0	<b>INT0 external edge interrupt enable.</b> It is an edge interrupt. The edge can be configured as single posedge, negedge, or both.

# Si4010-C2

## SFR Definition 23.8. EIE1

Bit	7	6	5	4	3	2	1	0
Name	eie1_unused[7:5]			evoid1	evoid0	efc	ei2c	espi
Type	R/W	R/W	R/W	R/W	R/W	R/W	R/W	R/W
Reset	0	0	0	0	0	0	0	0

SFR Address = 0xE6

Bit	Name	Function
7:5	eie1_unused[7:5]	<b>Reserved.</b> Read as 0x0. Write has no effect.
4	evoid1	<b>VOID1 interrupt enable.</b>
3	evoid0	<b>VOID0 interrupt enable.</b>
2	efc	<b>Frequency counter interrupt enable.</b>
1	ei2c	<b>I2C interrupt enable.</b>
0	espi	<b>SPI interrupt enable.</b>

## SFR Definition 23.9. EIE2

Bit	7	6	5	4	3	2	1	0
Name	eie2[7:0]							
Type	R							
Reset	0	0	0	0	0	0	0	0

SFR Address = 0xE7

Bit	Name	Function
7:0	eie2[7:0]	<b>Extended interrupt enable, byte 2.</b> Not implemented, reserved space to be compliant with 8052 architecture. Reserved. Read as 0x0. Write has no effect.

**SFR Definition 23.10. IP**

Bit	7	6	5	4	3	2	1	0
Name	ip_unused	pint1	ptmr3	Pods	prtc	pdmd	ptmr2	pint0
Type	R/W	R/W	R/W	R/W	R/W	R/W	R/W	R/W
Reset	1	0	0	0	0	0	0	0

SFR Address = 0xB8

Bit	Name	Function
7	ip_unused	Unused. Read as 1, write don't care.
6	pint1	INT1 external edge interrupt priority.
5	ptmr3	Timer 3 interrupt priority.
4	Pods	Output data serializer interrupt priority.
3	prtc	Real time clock interrupt priority.
2	pdmd	Demodulator interrupt priority.
1	ptmr2	Timer 2 interrupt priority.
0	pint0	INT0 external edge interrupt priority.

**SFR Definition 23.11. EIP1**

Bit	7	6	5	4	3	2	1	0
Name	eip1_unused[7:5]			pvoid1	pvoid0	pfcc	pi2c	pspi
Type	R/W	R/W	R/W	R/W	R/W	R/W	R/W	R/W
Reset	0	0	0	0	0	0	0	0

SFR Address = 0xF6

Bit	Name	Function
7:5	eip1_unused[7:5]	Reserved. Read as 0x0. Write has no effect.
4	pvoid1	VOID1 interrupt priority.
3	pvoid0	VOID0 interrupt priority.
2	pfcc	Frequency counter interrupt priority.
1	pi2c	I2C interrupt priority.
0	pspi	SPI interrupt priority.

# Si4010-C2

---

## SFR Definition 23.12. EIP2

---

Bit	7	6	5	4	3	2	1	0
Name	eip2[7:0]							
Type	R							
Reset	0	0	0	0	0	0	0	0

SFR Address = 0xF7

Bit	Name	Function
7:0	eip2[7:0]	<b>Extended interrupt priority, byte 2.</b> Not implemented, reserved space to be compliant with 8052 architecture. Reserved. Read as 0x0. Write has no effect.

---

## SFR Definition 23.13. INT\_FLAGS

---

Bit	7	6	5	4	3	2	1	0
Name	int_unused[7:5]			void1_flag	void0_flag	ods_flag	int1_flag	int0_flag
Type	R			R/W	R/W	R/W	R/W	R/W
Reset	0	0	0	0	0	0	0	0

SFR Address = 0xBF

Bit	Name	Function
7:5	int_unused [7:5]	<b>Reserved.</b> Read as 0x0. Write has no effect.
4	void1_flag	<b>VOID1 flag.</b> Spare interrupt flag for future hardware expansion. Interrupt can be invoked by software only by writing 1 here. Test use only.
3	void0_flag	<b>VOID0 flag.</b> Spare interrupt flag for future hardware expansion. Interrupt can be invoked by software only by writing 1 here. Test use only.
2	ods_flag	<b>ODS flag.</b> Set when the Tx holding register becomes empty. It must be cleared by software BEFORE writing a new byte into the ODS Tx register. Hardware will not clear this bit.
1	int1_flag	<b>INT1 flag.</b> Set by the selected GPIO input by a selected edge. It gets set irrespective of the EINT0 setting. It must be cleared by software. Hardware will not clear this bit.
0	int0_flag	<b>INT0 flag.</b> Set by the selected GPIO input by a selected edge. It gets set irrespective of the EINT0 setting. It must be cleared by software. Hardware will not clear this bit

#### SFR Definition 23.14. TMR\_CKSEL

Bit	7	6	5	4	3	2	1	0
<b>Name</b>	tmr3h_mode[7:6]		tmr3l_mode[5:4]		tmr2h_mode[3:2]		tmr2l_mode[1:0]	
<b>Type</b>	R/W	R/W	R/W	R/W	R/W	R/W	R/W	R/W
<b>Reset</b>	0	0	0	0	0	0	0	0

SFR Address = 0xC9

Bit	Name	Function
7:6	tmr3h_mode[7:6]	<b>Timer 3 high half clock source if the timer works in split mode.</b>
5:4	tmr3l_mode[5:4]	<b>Timer 2 low half in split mode or full timer in full mode clock selection.</b>
3:2	tmr2h_mode[3:2]	<b>Timer 2 high half clock source if the timer works in split mode.</b>
1:0	tmr2l_mode[1:0]	<b>Timer 2 low half in split mode or full timer in full mode clock selection.</b> Clock selection encoding is the same for all 4 halves defined in this register: 0 .. clk_sys 1 .. pulse_div .. clk_sys/12 2 .. pulse_0 .. 5.12us 3 .. pulse_1 .. 100us

# Si4010-C2

## SFR Definition 23.15. TMR2CTRL

Bit	7	6	5	4	3	2	1	0
Name	tmr2inth	tmr2intl	tmr2intl_en	tmr2split	tmr2h_cap	tmr2l_cap	tmr2h_run	tmr2l_run
Type	R/W	R/W	R/W	R/W	R/W	R/W	R/W	R/W
Reset	0	0	0	0	0	0	0	0

SFR Address = 0xC8

Bit	Name	Function
7	tmr2inth	Interrupt flag for timer high half in split configuration or overall 16 bit timer in wide configuration. It gets set when the high half of the timer overflows or there is a capture event for the high half.
6	tmr2intl	<b>Interrupt flag for the timer low half.</b> It gets set when the low half overflows in timer mode or by capture event of the low half in capture mode. Software must clear this bit, hardware will not clear it.  Note that his bit is set when the low half of the timer overflows even if we operate in wide configuration.  When in wide configuration and in capture mode this bit is set when the high half of the timer overflows. Since in that case the capture event is the same for both halves, the capture event sets the TMR2INTH interrupt flag. Then this TMR2INTL can be used as a flag that the timer overflow, serving as an additional 17-th timer bit in capture mode in wide configuration
5	tmr2intl_en	<b>Enable interrupt generation from the low half of the timer.</b> The overall timer interrupt request signal is: TMR2 interrupt request = TMR2INTH   (TMR2INTL & TMR2INTL_EN)
4	tmr2split	<b>Split configuration selection.</b> 0 .. timer operates in wide configuration as 16 bit timer. The low half controls control the whole timer. 1 .. timer operates in split configuration. Both halves are controlled independently.
3	tmr2h_cap	If set, then TMR2H high half operates in capture mode if the timer is in split configuration. Ignored if timer operates in wide configuration.
2	tmr2l_cap	If set, then TMR2L low half operates in capture mode if the timer is in split configuration, or the whole timer operates in capture mode if in wide configuration.
1	tmr2h_run	TMR2H high half enable in split configuration, ignored if timer operates in wide configuration.
0	tmr2l_run	TMR2L low half enable in split configuration, whole timer enable in wide configuration.



**SFR Definition 23.16. TMR2RL**

Bit	7	6	5	4	3	2	1	0
Name	tmr2rl[7:0]							
Type	R/W							
Reset	0	0	0	0	0	0	0	0

SFR Address = 0xCA

Bit	Name	Function
7:0	tmr2rl[7:0]	<b>Timer 2 capture/reload register. LSB byte.</b> Two halves are not double buffered. Write to each of the halves takes effect immediately. If the timer or respective half operates in capture mode this register holds the capture value. If the timer or respective half operates in timer mode this register holds the reload value.

**SFR Definition 23.17. TMR2RH**

Bit	7	6	5	4	3	2	1	0
Name	tmr2rh[7:0]							
Type	R/W							
Reset	0	0	0	0	0	0	0	0

SFR Address = 0xCA

Bit	Name	Function
7:0	tmr2rh[7:0]	<b>Timer 2 capture/reload register. MSB byte.</b>

# Si4010-C2

## SFR Definition 23.18. TMR2RL

Bit	7	6	5	4	3	2	1	0
Name	tmr2rl[7:0]							
Type	R/W							
Reset	0	0	0	0	0	0	0	0

SFR Address = 0xCC

Bit	Name	Function
7:0	tmr2rl[7:0]	Timer 2 actual timer value. LSB byte.

## SFR Definition 23.19. TMR2RH

Bit	7	6	5	4	3	2	1	0
Name	tmr2rh[7:0]							
Type	R/W							
Reset	0	0	0	0	0	0	0	0

SFR Address = 0xCD

Bit	Name	Function
7:0	tmr2rh[7:0]	Timer 2 actual timer value. MSB byte.

## SFR Definition 23.20. TMR2RH

Bit	7	6	5	4	3	2	1	0
Name	tmr2rh[7:0]							
Type	R/W							
Reset	0	0	0	0	0	0	0	0

SFR Address = 0xCD

Bit	Name	Function
7:0	tmr2rh[7:0]	Timer 2 actual timer value. MSB byte.

**SFR Definition 23.21. TMR3CTRL**

Bit	7	6	5	4	3	2	1	0
Name	tmr3inth	tmr3intl	tmr3intl_en	tmr3split	tmr3h_cap	tmr3l_cap	tmr3h_run	tmr3l_run
Type	R/W	R/W	R/W	R/W	R/W	R/W	R/W	R/W
Reset	0	0	0	0	0	0	0	0

SFR Address = 0xB9

Bit	Name	Function
7	tmr3inth	Interrupt flag for timer high half in split configuration or overall 16 bit timer in wide configuration. It gets set when the high half of the timer overflows or there is a capture event for the high half.
6	tmr3intl	<b>Interrupt flag for the timer low half.</b> It gets set when the low half overflows in timer mode or by capture event of the low half in capture mode. Software must clear this bit, hardware will not clear it.  Note that his bit is set when the low half of the timer overflows even if we operate in wide configuration.  When in wide configuration and in capture mode this bit is set when the high half of the timer overflows. Since in that case the capture event is the same for both halves, the capture event sets the TMR3INTH interrupt flag. Then this TMR3INTL can be used as a flag that the timer overflow, serving as an additional 17-th timer bit in capture mode in wide configuration.
5	tmr3intl_en	<b>Enable interrupt generation from the low half of the timer.</b> The overall timer interrupt request signal is: TMR3 interrupt request = TMR3INTH   (TMR3INTL & TMR3INTL_EN)
4	tmr3split	<b>Split configuration selection.</b>  0 .. timer operates in wide configuration as 16-bit timer. The low half controls control the whole timer. 1 .. timer operates in split configuration. Both halves are controlled independently.
3	tmr3h_cap	If set then TMR3H high half operates in capture mode if the timer is in split configuration. Ignored if timer operates in wide configuration.
2	tmr3l_cap	If set, then TMR3L low half operates in capture mode if the timer is in split configuration, or the whole timer operates in capture mode if in wide configuration.
1	tmr3h_run	TMR3H high half enable in split configuration, ignored if timer operates in wide configuration.
0	tmr3l_run	TMR3L low half enable in split configuration, whole timer enable in wide configuration.

# Si4010-C2

---

## SFR Definition 23.22. TMR3RL

---

Bit	7	6	5	4	3	2	1	0
Name	tmr3rl[7:0]							
Type	R/W							
Reset	0	0	0	0	0	0	0	0

SFR Address = 0xBA

Bit	Name	Function
7:0	tmr3rl[7:0]	<b>Timer 3 capture/reload register. LSB byte.</b> Two halves are not double buffered. Write to each of the halves takes effect immediately. If the timer or respective half operates in capture mode, this register holds the capture value. If the timer or respective half operates in timer mode, this register holds the reload value.

---

## SFR Definition 23.23. TMR3RH

---

Bit	7	6	5	4	3	2	1	0
Name	tmr3rh[7:0]							
Type	R/W							
Reset	0	0	0	0	0	0	0	0

SFR Address = 0xBB

Bit	Name	Function
7:0	tmr3rh[7:0]	<b>Timer 3 capture/reload register. MSB byte.</b>

**SFR Definition 23.24. TMR3RL**

Bit	7	6	5	4	3	2	1	0
Name	tmr3rl[7:0]							
Type	R/W							
Reset	0	0	0	0	0	0	0	0

SFR Address = 0xBC

Bit	Name	Function
7:0	tmr3rl[7:0]	Timer 3 actual timer value. LSB byte.

**SFR Definition 23.25. TMR3H**

Bit	7	6	5	4	3	2	1	0
Name	tmr3h[7:0]							
Type	R/W							
Reset	0	0	0	0	0	0	0	0

SFR Address = 0xBC

Bit	Name	Function
7:0	tmr3h[7:0]	Timer 3 actual timer value. MSB byte.

# Si4010-C2

## SFR Definition 23.26. RTC\_CTRL

Bit	7	6	5	4	3	2	1	0
Name	rtc_int	rtc_ena	rtc_clr	rtc_unused[4:3]		rtc_div[2:0]		
Type	R/W	R/W	W	R		R/W		
Reset	0	0	0	0	0	0	0	0

SFR Address = 0x9C

Bit	Name	Function
7	rtc_int	<b>Interrupt flag.</b> Set after the time interval set by RTC_DIV field elapses. Software must clear the flag, hardware will not clear it.
6	rtc_ena	<b>RTC enable.</b> If 1 then the rtc_tick and bottom part of the pulse generator starts running where it left off. If RTC_DIV >= 3 then top half also starts.
5	rtc_clr	<b>Write only.</b> Write 1 will clear the pulse generator, but will leave the rtc_tick generator intact! See the RTC_TICKCLR in the SYSGEN register for clearing the rtc_tick counter.
4:3	rtc_unused [4:3]	<b>Reserved.</b> Read as 0x0. Write has no effect.
2:0	rtc_div[2:0]	Select the divider of the rtc_tick to determine the interval for the RTC interrupt generation. Decimal values of the field:  0 .. No int generation 1 .. 100us .. it is a 20/19 divider 2 .. 200us 3 .. 400us 4 .. 800us 5 .. 1ms 6 .. 2ms 7 .. 5ms

**SFR Definition 23.27. GFM\_DATA**

Bit	7	6	5	4	3	2	1	0
Name	gfm_data[7:0]							
Type	R/W							
Reset	0	0	0	0	0	0	0	0

SFR Address = 0x84

Bit	Name	Function
7:0	gfm_data [7:0]	GF multiplier data processing. Write a value here registers the data for processing. Processed data is registered into the same register with single clk_sys cycle delay. Read from this register reads the processed multiplied data. The register GFM_CONST must be written before GFM_DATA is written.

**SFR Definition 23.28. GFM\_CONST**

Bit	7	6	5	4	3	2	1	0
Name	gfm_const[7:0]							
Type	R/W							
Reset	0	0	0	0	0	0	0	0

SFR Address = 0x85

Bit	Name	Function
7:0	gfm_data [7:0]	GF multiplier constant register. This is the constant by which the GFM_DATA is multiplied by. It has to be written prior to GFM_DATA

# Si4010-C2

---

---

## SFR Definition 23.29. SBOX\_DATA

---

Bit	7	6	5	4	3	2	1	0
Name	sbox_data[7:0]							
Type	R/W							
Reset	0	0	0	0	0	0	0	0

SFR Address = 0x86

Bit	Name	Function
7:0	sbox_data [7:0]	AES SBox processing. Writing a value here registers the data for processing. Processed data is registered into the same register with single clk_sys cycle delay. Read from this register reads the processed data. The type of SBox processing is controlled by AES_DECRYPT bit.



## 22. CIP-51 Microcontroller

The MCU system controller core is the CIP-51 microcontroller. The CIP-51 is fully compatible with the MCS-51™ instruction set; standard 803x/805x assemblers and compilers can be used to develop software. The MCU family has a superset of all the peripherals included with a standard 8051. The CIP-51 also includes on-chip debug hardware, and interfaces directly with the analog and digital subsystems providing a complete RF transmitter solution in a single integrated circuit.

The CIP-51 Microcontroller core implements the standard 8051 organization and peripherals as well as additional custom peripherals and functions to extend its capability. The CIP-51 includes the following features:

- ▮ Fully Compatible with MCS-51 Instruction Set
- ▮ 24 MIPS Peak Throughput with 24 MHz Clock
- ▮ 0 to 24 MHz Clock Frequency
- ▮ Extended Interrupt Handler
- ▮ Power Management Modes
- ▮ On-chip Debug Logic
- ▮ Program and Data Memory Security

### Performance

The CIP-51 employs a pipelined architecture that greatly increases its instruction throughput over the standard 8051 architecture. In a standard 8051, all instructions except for MUL and DIV take 12 or 24 system clock cycles to execute, and usually have a maximum system clock of 12 MHz. By contrast, the CIP-51 core executes 70% of its instructions in one or two system clock cycles, with no instructions taking more than eight system clock cycles.

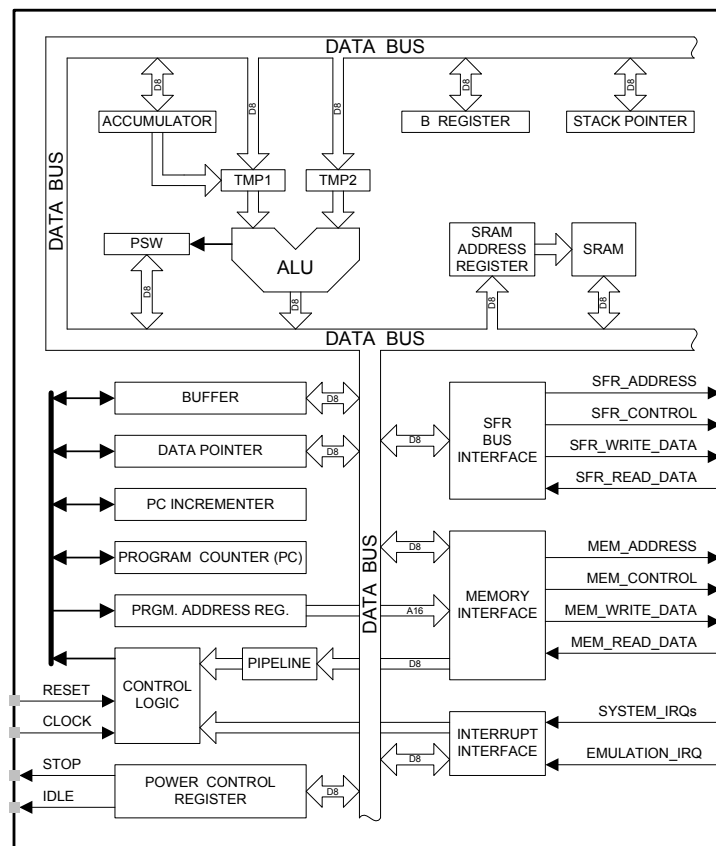

Figure 22.1. CIP-51 Block Diagram

# Si4010-C2

With the CIP-51's maximum system clock at 24 MHz, it has a peak throughput of 24 MIPS. The CIP-51 has a total of 109 instructions. The table below shows the total number of instructions in the function of the required clock cycles.

Clocks to Execute	1	2	2/3	3	3/4	4	4/5	5	8
Number of Instructions	26	50	5	14	7	3	1	2	1

## 22.1. Instruction Set

The instruction set of the CIP-51 System Controller is fully compatible with the standard MCS-51™ instruction set. Standard 8051 development tools can be used to develop software for the CIP-51. All CIP-51 instructions are the binary and functional equivalent of their MCS-51™ counterparts, including opcodes, addressing modes and effect on PSW flags. However, instruction timing is different than that of the standard 8051.

### 22.1.1. Instruction and CPU Timing

In many 8051 implementations, a distinction is made between machine cycles and clock cycles, with machine cycles varying from 2 to 12 clock cycles in length. However, the CIP-51 implementation is based solely on clock cycle timing. All instruction timings are specified in terms of clock cycles.

Due to the pipelined architecture of the CIP-51, most instructions execute in the same number of clock cycles as there are program bytes in the instruction. Conditional branch instructions take one less clock cycle to complete when the branch is not taken as opposed to when the branch is taken. Table 22.1 is the CIP-51 Instruction Set Summary, which includes the mnemonic, number of bytes, and number of clock cycles for each instruction.

Table 22.1. CIP-51 Instruction Set Summary

Mnemonic	Description	Bytes	Clock Cycles
<b>Arithmetic Operations</b>			
ADD A, Rn	Add register to A	1	1
ADD A, direct	Add direct byte to A	2	2
ADD A, @Ri	Add indirect RAM to A	1	2
ADD A, #data	Add immediate to A	2	2
ADDC A, Rn	Add register to A with carry	1	1
ADDC A, direct	Add direct byte to A with carry	2	2
ADDC A, @Ri	Add indirect RAM to A with carry	1	2
ADDC A, #data	Add immediate to A with carry	2	2
SUBB A, Rn	Subtract register from A with borrow	1	1
SUBB A, direct	Subtract direct byte from A with borrow	2	2
SUBB A, @Ri	Subtract indirect RAM from A with borrow	1	2
SUBB A, #data	Subtract immediate from A with borrow	2	2
INC A	Increment A	1	1
INC Rn	Increment register	1	1
INC direct	Increment direct byte	2	2
INC @Ri	Increment indirect RAM	1	2
DEC A	Decrement A	1	1
DEC Rn	Decrement register	1	1
DEC direct	Decrement direct byte	2	2
DEC @Ri	Decrement indirect RAM	1	2
INC DPTR	Increment Data Pointer	1	1
MUL AB	Multiply A and B	1	4
DIV AB	Divide A by B	1	8
DA A	Decimal adjust A	1	1
<b>Logical Operations</b>			
ANL A, Rn	AND Register to A	1	1
ANL A, direct	AND direct byte to A	2	2
ANL A, @Ri	AND indirect RAM to A	1	2
ANL A, #data	AND immediate to A	2	2
ANL direct, A	AND A to direct byte	2	2
ANL direct, #data	AND immediate to direct byte	3	3
ORL A, Rn	OR Register to A	1	1
ORL A, direct	OR direct byte to A	2	2
ORL A, @Ri	OR indirect RAM to A	1	2
ORL A, #data	OR immediate to A	2	2
ORL direct, A	OR A to direct byte	2	2
ORL direct, #data	OR immediate to direct byte	3	3
XRL A, Rn	Exclusive-OR Register to A	1	1
XRL A, direct	Exclusive-OR direct byte to A	2	2
XRL A, @Ri	Exclusive-OR indirect RAM to A	1	2
XRL A, #data	Exclusive-OR immediate to A	2	2
XRL direct, A	Exclusive-OR A to direct byte	2	2

**Table 22.1. CIP-51 Instruction Set Summary (Continued)**

Mnemonic	Description	Bytes	Clock Cycles
XRL direct, #data	Exclusive-OR immediate to direct byte	3	3
CLR A	Clear A	1	1
CPL A	Complement A	1	1
RL A	Rotate A left	1	1
RLC A	Rotate A left through Carry	1	1
RR A	Rotate A right	1	1
RRC A	Rotate A right through Carry	1	1
SWAP A	Swap nibbles of A	1	1
<b>Data Transfer</b>			
MOV A, Rn	Move Register to A	1	1
MOV A, direct	Move direct byte to A	2	2
MOV A, @Ri	Move indirect RAM to A	1	2
MOV A, #data	Move immediate to A	2	2
MOV Rn, A	Move A to Register	1	1
MOV Rn, direct	Move direct byte to Register	2	2
MOV Rn, #data	Move immediate to Register	2	2
MOV direct, A	Move A to direct byte	2	2
MOV direct, Rn	Move Register to direct byte	2	2
MOV direct, direct	Move direct byte to direct byte	3	3
MOV direct, @Ri	Move indirect RAM to direct byte	2	2
MOV direct, #data	Move immediate to direct byte	3	3
MOV @Ri, A	Move A to indirect RAM	1	2
MOV @Ri, direct	Move direct byte to indirect RAM	2	2
MOV @Ri, #data	Move immediate to indirect RAM	2	2
MOV DPTR, #data16	Load DPTR with 16-bit constant	3	3
MOVC A, @A+DPTR	Move code byte relative DPTR to A	1	3
MOVC A, @A+PC	Move code byte relative PC to A	1	3
MOVX A, @Ri	Move external data (8-bit address) to A	1	3
MOVX @Ri, A	Move A to external data (8-bit address)	1	3
MOVX A, @DPTR	Move external data (16-bit address) to A	1	3
MOVX @DPTR, A	Move A to external data (16-bit address)	1	3
PUSH direct	Push direct byte onto stack	2	2
POP direct	Pop direct byte from stack	2	2
XCH A, Rn	Exchange Register with A	1	1
XCH A, direct	Exchange direct byte with A	2	2
XCH A, @Ri	Exchange indirect RAM with A	1	2
XCHD A, @Ri	Exchange low nibble of indirect RAM with A	1	2
<b>Boolean Manipulation</b>			
CLR C	Clear Carry	1	1
CLR bit	Clear direct bit	2	2
SETB C	Set Carry	1	1
SETB bit	Set direct bit	2	2
CPL C	Complement Carry	1	1
CPL bit	Complement direct bit	2	2

Table 22.1. CIP-51 Instruction Set Summary (Continued)

Mnemonic	Description	Bytes	Clock Cycles
ANL C, bit	AND direct bit to Carry	2	2
ANL C, /bit	AND complement of direct bit to Carry	2	2
ORL C, bit	OR direct bit to carry	2	2
ORL C, /bit	OR complement of direct bit to Carry	2	2
MOV C, bit	Move direct bit to Carry	2	2
MOV bit, C	Move Carry to direct bit	2	2
JC rel	Jump if Carry is set	2	2/3
JNC rel	Jump if Carry is not set	2	2/3
JB bit, rel	Jump if direct bit is set	3	3/4
JNB bit, rel	Jump if direct bit is not set	3	3/4
JBC bit, rel	Jump if direct bit is set and clear bit	3	3/4
<b>Program Branching</b>			
ACALL addr11	Absolute subroutine call	2	3
LCALL addr16	Long subroutine call	3	4
RET	Return from subroutine	1	5
RETI	Return from interrupt	1	5
AJMP addr11	Absolute jump	2	3
LJMP addr16	Long jump	3	4
SJMP rel	Short jump (relative address)	2	3
JMP @A+DPTR	Jump indirect relative to DPTR	1	3
JZ rel	Jump if A equals zero	2	2/3
JNZ rel	Jump if A does not equal zero	2	2/3
CJNE A, direct, rel	Compare direct byte to A and jump if not equal	3	4/5
CJNE A, #data, rel	Compare immediate to A and jump if not equal	3	3/4
CJNE Rn, #data, rel	Compare immediate to Register and jump if not equal	3	3/4
CJNE @Ri, #data, rel	Compare immediate to indirect and jump if not equal	3	4/5
DJNZ Rn, rel	Decrement Register and jump if not zero	2	2/3
DJNZ direct, rel	Decrement direct byte and jump if not zero	3	3/4
NOP	No operation	1	1

## Notes on Registers, Operands and Addressing Modes:

**Rn**—Register R0–R7 of the currently selected register bank.

**@Ri**—Data RAM location addressed indirectly through R0 or R1.

**rel**—8-bit, signed (twos complement) offset relative to the first byte of the following instruction. Used by SJMP and all conditional jumps.

**direct**—8-bit internal data location's address. This could be a direct-access Data RAM location (0x00–0x7F) or an SFR (0x80–0xFF).

**#data**—8-bit constant

**#data16**—16-bit constant

**bit**—Direct-accessed bit in Data RAM or SFR

**addr11**—11-bit destination address used by ACALL and AJMP. The destination must be within the same 2 kB page of program memory as the first byte of the following instruction.

**addr16**—16-bit destination address used by LCALL and LJMP. The destination may be anywhere within the 8 kB program memory space.

There is one unused opcode (0xA5) that performs the same function as NOP.  
All mnemonics copyrighted © Intel Corporation 1980.

## 22.2. CIP-51 Register Descriptions

Following are descriptions of SFRs related to the operation of the CIP-51 System Controller. Reserved bits should always be written to the value indicated in the SFR description. Future product versions may use these bits to implement new features in which case the reset value of the bit will be the indicated value, selecting the feature's default state. Detailed descriptions of the remaining SFRs are included in the sections of the data sheet associated with their corresponding system function.

### SFR Definition 22.1. DPL

Bit	7	6	5	4	3	2	1	0
Name	DPL[7:0]							
Type	R/W							
Reset	0	0	0	0	0	0	0	0

SFR Address = 0x82

Bit	Name	Function
7:0	DPL[7:0]	<b>Data Pointer Low.</b> The DPL register is the low byte of the 16-bit DPTR.

### SFR Definition 22.2. DPH

Bit	7	6	5	4	3	2	1	0
Name	DPH[7:0]							
Type	R/W							
Reset	0	0	0	0	0	0	0	0

SFR Address = 0x83

Bit	Name	Function
7:0	DPH[7:0]	<b>Data Pointer High.</b> The DPH register is the high byte of the 16-bit DPTR.

# Si4010-C2

---

## SFR Definition 22.3. SP

---

Bit	7	6	5	4	3	2	1	0
Name	SP[7:0]							
Type	R/W							
Reset	0	0	0	0	0	1	1	1

SFR Address = 0x81

Bit	Name	Function
7:0	SP[7:0]	<b>Stack Pointer.</b> The Stack Pointer holds the location of the top of the stack. The stack pointer is incremented before every PUSH operation. The SP register defaults to 0x07 after reset.

---

## SFR Definition 22.4. ACC

---

Bit	7	6	5	4	3	2	1	0
Name	ACC[7:0]							
Type	R/W							
Reset	0	0	0	0	0	0	0	0

SFR Address = 0xE0; Bit-Addressable

Bit	Name	Function
7:0	ACC[7:0]	<b>Accumulator.</b> This register is the accumulator for arithmetic operations.



---



---

**SFR Definition 22.5. B**

---

<b>Bit</b>	<b>7</b>	<b>6</b>	<b>5</b>	<b>4</b>	<b>3</b>	<b>2</b>	<b>1</b>	<b>0</b>
<b>Name</b>	B[7:0]							
<b>Type</b>	R/W							
<b>Reset</b>	0	0	0	0	0	0	0	0

SFR Address = 0xF0; Bit-Addressable

<b>Bit</b>	<b>Name</b>	<b>Function</b>
7:0	B[7:0]	<b>B Register.</b> This register serves as a second accumulator for certain arithmetic operations.

# Si4010-C2

## SFR Definition 22.6. PSW

Bit	7	6	5	4	3	2	1	0
Name	CY	AC	F0	RS[1:0]		OV	F1	PARITY
Type	R/W	R/W	R/W	R/W		R/W	R/W	R
Reset	0	0	0	0	0	0	0	0

SFR Address = 0xD0; Bit-Addressable

Bit	Name	Function
7	CY	<b>Carry Flag.</b> This bit is set when the last arithmetic operation resulted in a carry (addition) or a borrow (subtraction). It is cleared to logic 0 by all other arithmetic operations.
6	AC	<b>Auxiliary Carry Flag.</b> This bit is set when the last arithmetic operation resulted in a carry into (addition) or a borrow from (subtraction) the high order nibble. It is cleared to logic 0 by all other arithmetic operations.
5	F0	<b>User Flag 0.</b> This is a bit-addressable, general purpose flag for use under software control.
4:3	RS[1:0]	<b>Register Bank Select.</b> These bits select which register bank is used during register accesses. 00: Bank 0, Addresses 0x00-0x07 01: Bank 1, Addresses 0x08-0x0F 10: Bank 2, Addresses 0x10-0x17 11: Bank 3, Addresses 0x18-0x1F
2	OV	<b>Overflow Flag.</b> This bit is set to 1 under the following circumstances: <ul style="list-style-type: none"> <li>▫ An ADD, ADDC, or SUBB instruction causes a sign-change overflow.</li> <li>▫ A MUL instruction results in an overflow (result is greater than 255).</li> <li>▫ A DIV instruction causes a divide-by-zero condition.</li> </ul> The OV bit is cleared to 0 by the ADD, ADDC, SUBB, MUL, and DIV instructions in all other cases.
1	F1	<b>User Flag 1.</b> This is a bit-addressable, general purpose flag for use under software control.
0	PARITY	<b>Parity Flag.</b> This bit is set to logic 1 if the sum of the eight bits in the accumulator is odd and cleared if the sum is even.

## 23. Memory Organization

The memory organization of the Si4010 is similar to that of a standard 8051. There are two separate memory spaces: program memory and data memory. Program and data memory share the same address space but are accessed via different instruction types. However, this device is unique since it has the program and data memory spaces combined into one. This is called a unified CODE and XDATA memory.

The device has a standard 8051 program and data address configuration. It includes 256 bytes of internal data RAM, with the upper 128 bytes dual-mapped. Indirect addressing accesses the upper 128 bytes of general purpose RAM, and direct addressing accesses the 128 byte SFR address space. The lower 128 bytes of internal RAM are accessible via direct and indirect addressing. The first 32 bytes are addressable as four banks of general purpose registers, and the next 16 bytes can be byte addressable or bit addressable.

Apart from the CPU core related internal memory, the device has the following memories:

- 4.5 kB of RAM .. it can be used both as program CODE and external data XDATA memory
- 12 kB of ROM .. it holds the Silicon Labs provided API (Application Programming Interface) routines. The ROM is not readable by the user.
- 256B hardware control registers mapped to XDATA address space (XREG)
- 8 kB of one time programmable (OTP) non-volatile memory (NVM)
- 128 bits of multiple time programmable (MTP) EEPROM. The EEPROM has an endurance of 50,000 updates per bit.

See Figure 23.1 for the MCU system memory map:

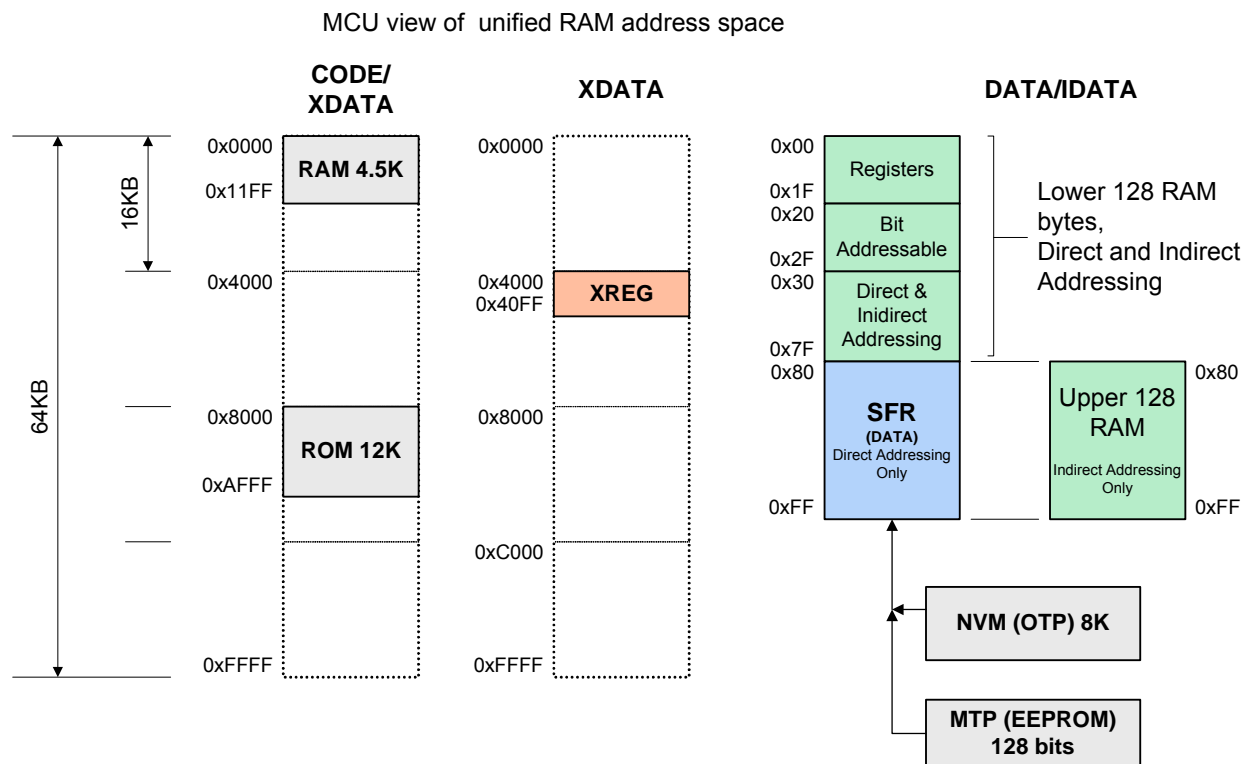

# Si4010-C2

---

## 23.1. Program Memory

Program memory consists of 4.5 kB for RAM and 12 kB of ROM. The device employs a unified CODE/XDATA RAM memory. On 8051 architecture the external data memory (XDATA) space is physically different from the program memory (CODE); they can be accessed with different instructions. On this device the RAM can store both CODE and XDATA at any location. The program memory is commonly called CODE memory, residing in CODE address space.

Both MOVC and MOVX instructions can be used to read data from the CODE/XDATA address space.

The ROM holds the Silicon Labs proprietary code and cannot be read by a user. Only code can be executed from ROM. If read is attempted by MOVC or MOVX instructions from ROM area the read value is undetermined. The NVM and MTP memories are not mapped to the CPU address space.

## 23.2. Internal Data Memory

The device implements 256 bytes of internal RAM mapped into the data memory space from 0x00 through 0xFF. The lower 128 bytes of data memory are used for general purpose registers and memory. Either direct or indirect addressing may be used to access the lower 128 bytes of data memory. Locations 0x00 through 0x1F are addressable as four banks of general purpose registers, each bank consisting of eight byte-wide registers. The next 16 bytes, locations 0x20 through 0x2F, may either be addressed as bytes or as 128 bit locations accessible with the direct addressing mode.

The upper 128 bytes of data memory are accessible only by indirect addressing. This region occupies the same address space as the Special Function Registers (SFR) but is physically separate from the SFR space. The addressing mode used by an instruction when accessing locations above 0x7F determines whether the CPU accesses the upper 128 bytes of data memory space or the SFRs. Instructions that use direct addressing will access the SFR space. Instructions using indirect addressing above 0x7F access the upper 128 bytes of data memory. Figure 23.1 illustrates the data memory organization.

## 23.3. External Data Memory

Even though it is called external memory, it resides on the chip. This is the data memory, up to 64 kB in size, which is accessible by MOVX instructions. For the original MCS-51™ architecture this memory resided physically external to the chip. This memory is commonly referred as XDATA memory.

The device implements shared CODE/XDATA memory. The 4.5 kB of RAM is shared between the CODE and XDATA. The CPU can run code from any location of that RAM, can read any location using MOVC and MOVX instructions, and can write any location by using MOVX instruction.

Important note: Linker of the user application has to be given proper regions of CODE and XDATA memory, which are mutually exclusive. Therefore, for example, the user cannot set the CODE region to be 0x0000 .. 0x1000 and XDATA region to be the very same at the same time. One has to specify two non-overlapping regions in the RAM area instead.

## 23.4. General Purpose Registers

The lower 32 bytes of data memory, locations 0x00 through 0x1F, may be addressed as four banks of general-purpose registers. Each bank consists of eight byte-wide registers designated R0 through R7. Only one of these banks may be enabled at a time. Two bits in the program status word, RS0 (PSW.3) and RS1 (PSW.4), select the active register bank. This allows fast context switching when entering subroutines and interrupt service routines. Indirect addressing modes use registers R0 and R1 as index registers.

---

### 23.5. Bit Addressable Locations

In addition to direct access to data memory organized as bytes, the sixteen data memory locations at 0x20 through 0x2F are also accessible as 128 individually addressable bits. Each bit has a bit address from 0x00 to 0x7F. Bit 0 of the byte at 0x20 has bit address 0x00 while bit 7 of the byte at 0x20 has bit address 0x07. Bit 7 of the byte at 0x2F has bit address 0x7F. A bit access is distinguished from a full byte access by the type of instruction used (bit source or destination operands as opposed to a byte source or destination).

The MCS-51™ assembly language allows an alternate notation for bit addressing of the form XX.B where XX is the byte address and B is the bit position within the byte.

For example, the instruction:

```
MOV C, 22.3h
```

moves the Boolean value at 0x13 (bit 3 of the byte at location 0x22) into the Carry flag.

### 23.6. Stack

A programmer's stack can be located anywhere in the 256 byte data memory. The stack area is designated using the Stack Pointer (SP, address 0x81) SFR. The SP will point to the last location used. The next value pushed on the stack is placed at SP+1 and then SP is incremented. A reset initializes the stack pointer to location 0x07; therefore, the first value pushed on the stack is placed at location 0x08, which is also the first register (R0) of register bank 1. Thus, if more than one register bank is to be used, the SP should be initialized to a location in the data memory not being used for data storage. The stack depth can extend up to 256 bytes.

### 23.7. Special Function Registers (SFR)

The direct-access data memory locations from 0x80 to 0xFF constitute the special function registers (SFRs). The SFRs provide control and data exchange with the CIP-51's resources and peripherals. The CIP-51 duplicates the SFRs found in a typical 8051 implementation as well as implementing additional SFRs used to configure and access the sub-systems unique to the MCU. This allows the addition of new functionality while retaining compatibility with the MCS-51™ instruction set. Table 25.1 lists the SFRs implemented in the device.

The SFR registers are accessed whenever the direct addressing mode is used to access memory locations from 0x80 to 0xFF. SFRs with addresses ending in 0x0 or 0x8 (e.g. P0, P1, IE, etc.) are bit-addressable as well as byte-addressable. All other SFRs are byte-addressable only. Unoccupied addresses in the SFR space are reserved for future use. Accessing these areas will have an indeterminate effect and should be avoided. Refer to the corresponding pages of the data sheet for a detailed description of each register.

### 23.8. Registers Mapped to XDATA Address Space (XREG)

Given the extensive requirement for the numerous hardware registers some of the registers are mapped to the XDATA space as shown in Figure 23.1. Those registers are accessible only by MOVX instructions and are viewed from the CPU as a regular external XDATA memory. Registers which are more than single byte wide are organized in big endian fashion (most significant byte on the lowest address) to comply with the Keil development toolchain. They can be declared as regular variables in higher level languages, like C.

Map of user accessible XREG registers is in Table 25.3.

### 23.9. NVM (OTP) Memory

NVM memory is only accessible indirectly through Silicon Labs provided API functions for NVM access initialization and read of formatted blocks of data generated by the NVM programmer. Programming of the NVM can be only done by Silicon Labs provided tools. It is not possible to program the NVM by writing to registers. See "System Boot and NVM Programming" on page 69 for details.

# Si4010-C2

The maximum number of read operations of the NVM memory is limited, but this limitation has effect only in extreme conditions. Consult the electrical specification section in this document, and with “ANxxx NVM Reliability Analysis.”

## 23.10. MTP (EEPROM) Memory

The MTP memory is a special block not organized as a usual memory. The memory output is mapped to the XDATA address space as a XREG register (abMTP\_RDATA[16]) 16 byte **read only** array at addresses 0x4040 .. 0x404F. Writing to the MTP memory can be done only indirectly by using the Silicon Labs provided API ROM functions.

To write to MTP the user must prepare an array of all 16 bytes in CODE/XDATA RAM. There is no byte access to MTP. Even if only a single bit is to be changed in MTP, the current content must be copied to the CODE/XDATA RAM in full, all 16 bytes. Then the desired bit has to be changed in that RAM copy and an API function has to be called to program the 16 byte changed data from RAM to MTP. The user can use the API MTP copy call to get the current content of MTP into CODE/XDATA RAM for modifications. If the MTP bit is not changing value the programming cycle is not counted against the maximum bit change durability of MTP. Therefore, programming the 16 byte MTP content unchanged from the current value has no effect on the longevity of the MTP.

There is no direct write access to MTP through registers. Silicon Labs API ROM functions must be used.

### XREG Definition 23.1. abMTP\_RDATA[16]

<b>Byte</b>	<b>15</b>	<b>14</b>	...	<b>1</b>	<b>0</b>
<b>Name</b>	abMTP_RDATA[0:15]				
<b>Type</b>	R				
<b>Reset</b>	—	—	...	—	—

XREG Address = 0x4040

<b>Byte</b>	<b>Name</b>	<b>Function</b>
15:0	abMTP_RDATA[0:15]	<b>MTP Read Data.</b> MTP 16-byte read only array.

---

## 24. System Boot and NVM Programming

The device does not include a Flash memory for permanent code or data storage. Instead, the device contains 4.5 kB of RAM, which can serve as a unified CODE and XDATA RAM memory. The device contains 8 kB of NVM (OTP) memory for user code and data storage. Small part of the NVM is reserved for Silicon Labs factory use and is not available to a user. In general more than 7 kB of NVM will be available for user application use.

### 24.1. Startup Overview

The code cannot be run directly from NVM, since it is not mapped directly to the CPU address space. Instead, upon device reset, the device goes through a boot process during which the factory chip configuration and the user application code and data is copied from NVM to the CODE/XDATA RAM. Only after the boot process finishes the user code starts being executed from CODE/XDATA RAM address 0x0000.

Therefore upon reset the device does not execute the user code immediately, but only after the boot process finishes. The time in between the device wakeup, either caused by cycling the power or waking up from the shutdown mode by button press, depends on the size of the user code load.

In general the startup time is about 2ms of fixed time plus 3.6 ms per 1 kB of user application code. For example, 4 kB application will incur

$$T_{\text{startup}} = 2 \text{ ms} + 3.6 \text{ ms} \times \text{User\_KB} = 2 \text{ ms} + 3.6 \text{ ms} \times 4 = 16.4 \text{ ms}$$

startup time before the user application starts being executed.

For debugging purposes user will not program the NVM, but will use the RAM for code development. In that case the device will only contain factory settings and go through much shorter startup routine, which would take less than 2 ms to finish.

## 24.2. Reset

Reset circuitry allows the controller to be easily placed in a predefined default condition. See “Reset Sources” on page 106 for details.

## 24.3. Chip Program Levels

The boot process starts by reading the NVM configuration bytes in the **Factory** region of NVM. The information about the programmed level of the chip is read first and the boot process acts accordingly.

After boot, the program level of the chip can be read as **NVM\_BLOWN[2:0]** field in the **PROTO\_CTRL** register.

From user point of view there are 3 program levels of the chip:

1. **Factory** .. blank part leaving the factory. The factory chip calibration is written into NVM. ROM and NVM **Factory** region is not readable by the user. Part can be used with debugging chain for software development and **User** load can be programmed to the part. Boot process initializes the part based on the **Factory** settings.
2. **User** .. same as **Factory** (blank) part, but with the **User** region in the NVM programmed with user code. The boot process will initialize the part according to the **Factory** settings and then (see Note 1. in section “24.5. Device Boot Process”) copies the **User** load to the CODE/XDATA or IRAM based on the **User** load. The code is not automatically run (see Note 2. in section “24.5. Device Boot Process”). The part can be used with IDE for further software development. The part is still opened for further NVM programming and the user can add additional data to the **User** region in the NVM. Debugging of the code loaded from NVM is possible. The user can modify the boot behavior of the **User** part by controlling two bits described later in the boot sequence description.  
This program level can be used two ways:
  - User programs the **User** code to check the load before finalizing the product.
  - Silicon Labs program most of the **User** code into the chip. Then the customer will add additional information specific for each chip on his own. For example, the customer may chose to let Silicon Labs program all the application data, but wants to program security keys into each chip on their own. This **User** level would be the chip program level delivered to a customer.
3. **Run** .. mission mode part, fully programmed for use in the field. No further NVM programming possible, no C2 interface access enabled, with the exception of special mode for retest. No possibility of IDE debug. The boot process is the same as in the case of **User** part, but after the user load is copied from NVM to RAM, the boot loader executes a jump to RAM address 0x0000 and the user application is executed. The C2 is not enabled in this mode with the retest exception, briefly described in this document.

The IDE debugging environment can be used only with the **Factory** and **User** program chip levels, not with the **Run** part.



---

## 24.4. NVM Organization

The 8 kB NVM (OTP) memory is virtually mapped to the device address space 0xE000 .. 0xFFFF. However, CPU can access NVM only indirectly using the predefined API calls in ROM.

The NVM address region is organized in the following fashion:

1. **Factory** region .. factory settings critical for chip functions. Size is variable based on the device configuration.
2. **User** region .. region available for User application load at boot time. If the user application is not going to use overlays, then this will be the only user data region used.
3. **User App** optional region .. optional region not visible at boot time. If the user application is using overlays, then the overlay code will be stored in this region. It will be up to the user to load the application code from the NVM to CODE/XDATA RAM at runtime based on the user application request. Application note will be devoted to this technique.
4. **Reserved** region .. last 64 bytes of NVM are reserved for factory use and not available for user load.

The **User** load can occupy the rest of the NVM. The user may decide that he will use overlays. That means that the boot routine will not copy all the data from NVM to RAM upon boot, but during the runtime of the user program the program itself will load data from NVM to the RAM as desired. Only the **User** region is known to boot routine and will be loaded during boot.

The **User App** region is the data region available to the user for a load to be loaded at runtime by the user program. The user will have to call the API NVM copy routine in that case. "AN518: Si4010 Memory Overlay Technique" describes this process in detail. In such a scenario, this NVM region will not be loaded by boot, but by the user application. That region of NVM is labeled as **User App** region in Figure 24.1, "NVM Address Map". Boot routine will not know about the data there.

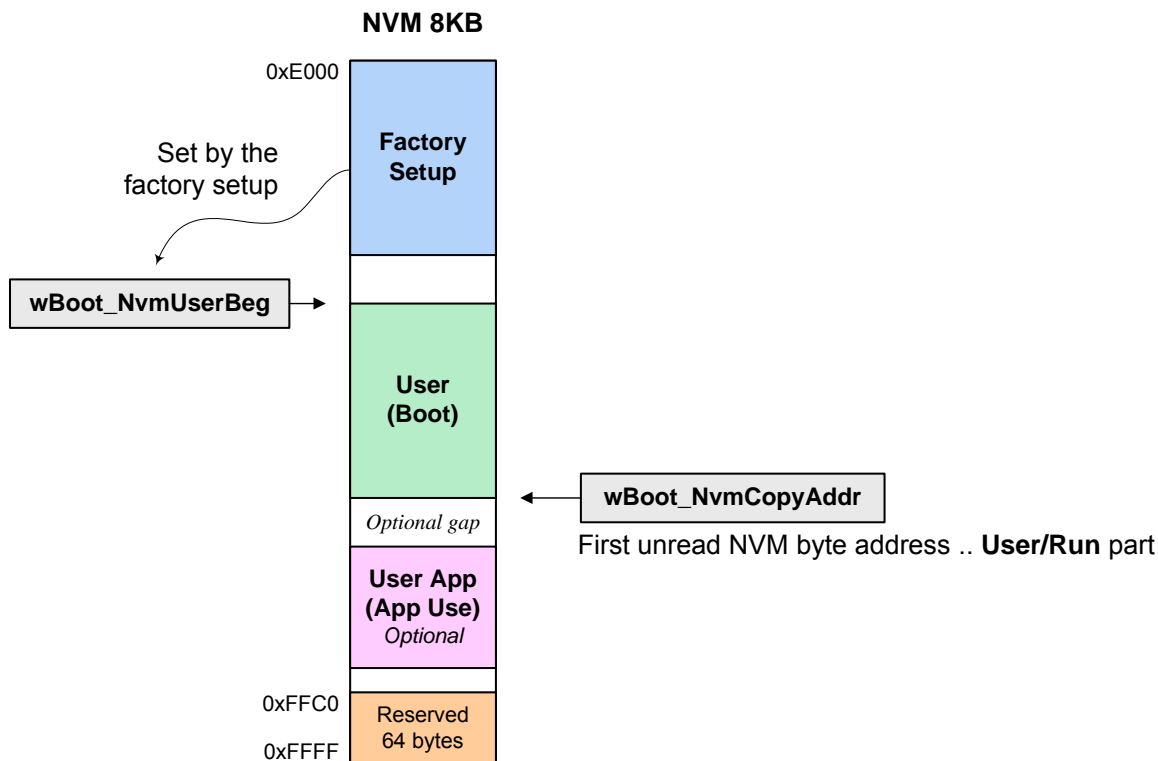

**Figure 24.1. NVM Address Map**

## 24.5. Device Boot Process

The boot process works in the following sequence:

1. Boot is invoked by cycling power to the internals of the chip (which includes power cycle to the whole chip), waking up by button press, by the sleep timer, or by pressing a **Reset** button in the IDE development platform.
2. The device will read the **Factory** part of the NVM to determine the device configuration and load the configuration values to appropriate registers and CODE/XDATA memory locations. Part of this process is setting the boot variable block at the end of the CODE/XDATA memory.
3. If the program level is **Factory** then the boot process will stop and will not execute any code. It will wait in an infinite loop for the debugging chain to load a user application to CODE/XDATA RAM and to allow that code execution from the IDE. More specifically, the boot hardware waits for the CODE\_RUN\_POR or CODE\_RUN\_SYS bits to be set in the BOOT\_FLAGS register. When using debugging chain and IDE, this is taken care of automatically by the IDE and there is no user intervention required.
4. If the program level is **User** then the same procedure is followed as for the **Factory** device. After that the boot procedure automatically (see Note 1.) continues to load **User** region from NVM to CODE/XDATA RAM and IRAM. After it finishes the device does not execute any code (see Note 2.) and goes to the same waiting infinite loop as described in item 3. for **Factory** device.

The user can modify the boot behavior of the **User** part by controlling the following two bits:

**Note 1.** BOOT\_TRIM\_POR bit in BOOT\_FLAGS .. Register cleared on power on reset. If this bit is 1, the boot loader will not load the **User** load but enables C2 and goes to the **boot\_flags** waiting loop. The part will behave as a **Factory** part. This bit has higher priority than the one below. Convenient for debugging until the power is cycled.

**Note 2.** USER\_CONT bit in PROT3\_CTRL in NVM .. Bit in the NVM protection register. Once set it

cannot be cleared. When this bit is 1, then after the Factory and User loads are loaded from NVM the boot loader enables C2 and runs the user code immediately, without any wait, by executing long jump to RAM address 0x0000. The IDE can still halt the chip and connect to it in a usual fashion. From the debug point of view there is no change. This bit corresponds to the **Exe User Boot** checkout on the NVM programmer GUI application.

5. If the program level is **Run** then the same boot procedures is followed as for the **User** device. When loading the **User** region is done, the user code is run by jumping to the 0x0000 address in CODE/XDATA RAM. The C2 interface is disabled and the chip can no longer be used with debug chain and IDE. The **Run** chip can be opened for retest, but the user has an option to limit **Retest** access or lock the chip out completely. See Section “24.11. Retest and Retest Configuration”.

**Note:** If the **Factory** or **User** part is powered up, the part will wait in an infinite loop, consuming power. Only the **Run** part executes code in CODE/XDATA RAM automatically. The user can also optionally make the **User** part to execute loaded code automatically as described above.

## 24.6. Error Handling During Boot

At the end of the boot process the **bBoot\_BootStat** byte variable contains the final status of the whole boot process. Bit field meanings are summarized in SFR Definition 24.1. The user application code should read that variable and if its value is other than 0x00 or 0x80, then it should decide whether it is safe to run the application at all. The boot success/fail single bit information is also contained in the **BOOT\_FLAGS** SFR register for easier access.

## 24.7. CODE/XDATA RAM Address Map

The 4.5 kB for internal RAM at the address range 0x0000 .. 0x11FF is the main area for the user program (CODE) and external data (XDATA). It is a unified memory, referred to as CODE/XDATA RAM in this document, so both CPU code (CODE) can be executed there and external data (XDATA) can reside there. External data are the data accessible by MOVX instructions. MOVC instructions can also be used to access data in that region.

After the boot of a **Run** part the CPU starts executing code from address 0x0000 in RAM. Therefore, user code must occupy the beginning of the RAM, followed by the XDATA.

**Important:** Linker of the user application has to be given proper regions of CODE and XDATA memory, which are mutually exclusive. Therefore, for example, the user cannot set the CODE region to be 0x0000 .. 0x1000 and XDATA region to be the very same at the same time. One has to specify two non-overlapping regions for CODE and XDATA in the CODE/XDATA RAM area instead.

The end of the CODE/XDATA RAM is reserved for internal Silicon Labs use. The CODE/XDATA RAM address space is divided into three parts:

1. **User** CODE/XDATA .. user application load. The boot process copies the user code and external initialized data from NVM to this region.
2. **Factory** data values .. variable length. Reserved for Silicon Labs use. The actual beginning of the Silicon Labs reserved area in RAM can be obtained by reading the boot WORD (2 byte) variable **wBoot\_DpramTrimBeg**. In big endian fashion it contains an address of the first reserved byte of the RAM. User can use the range 0x0000 .. (**wBoot\_DpramTrimBeg**) - 1 for application CODE and XDATA
3. Boot status variables .. variables in the region 0x11F3 .. 0x11FF are boot status variables set at the end of the boot process to inform the user application about the RAM size available for user application and about the final status of the boot process.

The visual representation of the RAM is in Figure 24.2. The detailed explanation of the boot control data variables are in Table 24.1 to SFR Definition 24.1.

# Si4010-C2

---

The user code or user development environment need to pay attention to the content of the following variables. All are stored in big endian fashion (MSB at the lower address):

- **wBoot\_DpramTrimBeg** .. this variable points to the first occupied (by factory data) address of RAM. Therefore, the user development platform needs to read this variable to determine what the available RAM area for user CODE/XDATA is.
- **bBoot\_BootStat** .. boot status result. User code should check this value at its beginning. If the value is different than 0x00 then the user could decide not to run its application since there was a problem with the boot.

Critical registers and variables corresponding to the NVM programming:

- **PROT0\_CTRL** .. this register, described in SFR Definition 24.4, contains the value of the current program level of chip. Depending on that value, the NVM programming utility will decide what can and cannot be programmed into the NVM.
- **PROT3\_CTRL** .. internal byte in the **Factory** region of the NVM controlling the boot process. It contains all the user code protection bits and modification of the User part boot process.
- **wBoot\_NvmUserBeg** .. address in NVM of the beginning of the **User** load. For programming the User load into the NVM, the NVM programming utility has to be properly configured by using this value. The value is read automatically by the NVM programming utility, and also is available through the IDE. Depending on the size of the **Factory** load the value of this variable can vary in between chip revisions. It could also vary from chip to chip, but that is unlikely.
- **wBoot\_NvmCopyAddr** .. first unread address of the NVM during boot. This address contains the NVM address the boot routine would read next. The last byte of the last data block read is at the address that is one less than the content of this variable: (**wBoot\_NvmCopyAddr**) - 1. The NVM programmer will use this information when additional block **User** data is needed to be programmed. As long as the part is in a program state **User** additional blocks can be added to the **User** load.

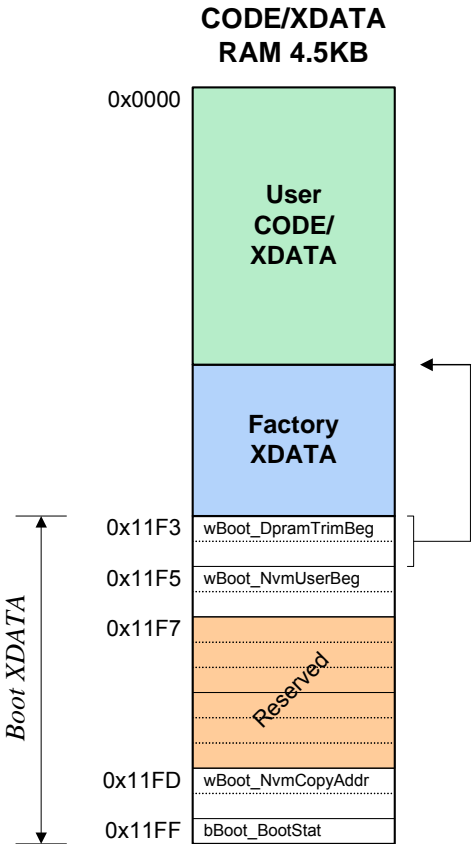

**Figure 24.2. CODE/XDATA RAM Address Map**

# Si4010-C2

## 24.8. Boot Status Variables

End of the CODE/XDATA RAM are reserved for boot status variables.

The user must pay attention to the content of the **wBoot\_DpramTrimBeg** variable. Its content points to the first reserved address for **Factory** Silicon Labs use.

**Important:** The CODE/XDATA area from this address on (increasing address) is reserved and must not be overwritten by **User** NVM load at boot time nor by user application at runtime.

If this area is accidentally overwritten by user application the chip will behave unpredictably. There is no hardware protection for this region.

Note that depending on the revision of the chip the **Factory** XDATA area can vary in size. The area is refreshed when reset is issued.

**Table 24.1. Boot XDATA Status Variables**

Register	Addr	Type	Description
wBoot_DpramTrimBeg	0x11F3	WORD*	Address of the first occupied byte by the Silicon Labs factory data in CODE/XDATA RAM. This variable is set after the boot. User must read the variable to determine where is the end of the usable CODE/XDATA RAM memory for user's use. The address is stored in big endian fashion; address MSB byte at the variable address location, followed by LSB byte on the next (address + 1) location.
wBoot_NvmUserBeg	0x11F5	WORD	Byte address of the first byte of the User load in the NVM memory. It is set by the Factory load. The User load MUST start at that address in NVM. Boot routine reads this variable before loading the User code after it finished loading the Factory load.
wBoot_NvmCopyAddr	0x11FD	WORD	First unread data address in NVM by the NVM copy routine <b>bNvm_CopyBlock</b> . After the boot is done this variable contains, in big endian, the NVM address of the first NVM byte not read by NVM copy routine. This is the first "empty" byte in NVM which is available for new data. The value of this variable is essential when the user wants to add more data to NVM later on.
bBoot_BootStat	0x11FF	BYTE	Boot status. User program can read this byte and decide whether the boot finished correctly. If not, then it can blink LED or not to continue with running the code. See the <b>bBoot_BootStat</b> bit description table.

**\*Note:** WORD is an unsigned 16 bit value, BYTE is an unsigned 8 bit value.

Boot status byte can or should be read by the user application at the very beginning to determine whether the copying of the **Factory** and **User** data from NVM to desired RAM destination was successful or not. When there are no errors, the value the **bBoot\_BootStat** variable should be 0x00 or 0x80. Any other value denotes a boot error. The user application then can decide whether to run or stall, if the user application was actually loaded to RAM. If the boot fails and the user application is not loaded to RAM, then unpredictable results may occur. The bit 7 of this variable contains a read value of GPIO[0] at the very beginning of the boot before the XO was optionally turned on.

**XDATA Variable Definition 24.1. bBoot\_BootStat**

Bit	7	6	5	4	3	2	1	0
Name	BS_GPIO_XTAL	RESERVED		BS_ERR_FACTORY[2:0]			BS_ERR_USER_NEXT	BS_ERR_USER_FIRST
Type	R	R	R	R			R	R
Reset	0/1	0	0	0	0	0	0	0

XDATA Address = 0x11FF

Bit	Name	Function
7	BS_GPIO_XTAL	<b>GPIO0 Read before Boot.</b> Read GPIO0 value at the very beginning of the boot prior to optionally turning on the XO (crystal oscillator).
6:5	Reserved	<b>Reserved.</b>
4:2	BS_ERR_FACTORY [2:0]	<b>Load of the Factory Data.</b> Load of the Factory data failed if value is other than 0x0
1	BS_ERR_USER_NEXT	<b>Load of the Second or Subsequent User block.</b> Load of the second or subsequent user block failed if other than 0.
0	BS_ERR_USER_FIRST	<b>Load of the First User block.</b> Load of the first user block failed if other than 0.

Apart from the CODE/XDATA RAM memory region there is a boot control and status SFR register, **BOOT\_FLAGS**. It controls the end of the boot and has error status bit, which is set when **bBoot\_BootStat** variable has other than 0x00 value. That is added for convenience so the user code can just check a single bit in SFR register rather than reading XDATA variable to determine whether boot finished successfully or not. If the **bBoot\_BootStat** XDATA variable is not 0x00, the boot fail flag is set in the **BOOT\_FLAGS** SFR.

The other bits control whether the user code will run after the boot. If the debugging chain is used and user code is loaded through IDE, this process is transparent to the user. Whenever the IDE connects to the device, it resets and halts the device, awaiting user. The user will generally not write to the **BOOT\_FLAGS** register.

However, if the user wants to make the **User** part to behave as a **Factory** part, then it is possible to write value 0x20 to the **BOOT\_FLAGS** register through IDE (see View -> Debug Windows -> SFR -> Boot window). Don't forget to press the **Refresh** IDE button for the change to take effect. Then until the power to the part is cycled the part would behave as a **Factory** part.

# Si4010-C2

## SFR Definition 24.2. BOOT\_FLAGS

Bit	7	6	5	4	3	2	1	0
Name	Reserved	Reserved	BOOT_TRIM_POR	CODE_RUN_POR	Reserved	BOOT_FAIL_SYS	BOOT_DONE_SYS	CODE_RUN_SYS
Type	R/W	R/W	R/W	R/W	R/W	R/W	R/W	R/W
Reset	0	0	0	0	0	0	0	0

SFR Address = 0xDD

Bit	Name	Function
7:6	Reserved	<b>Reserved.</b>
5	BOOT_TRIM_POR	<b>Force User Part to Act as a Factory Part.</b> For <b>User</b> part only: During the boot process load only <b>Factory</b> values and stop. By other words, act like a <b>Factory</b> part. Must be set for additional programming of the <b>User</b> part or for loading user test code to RAM when the part is programmed as <b>User</b> part. This bit has higher priority than the PROT3_CTRL.USER_CONT bit.
4	CODE_RUN_POR	<b>Run User Code in RAM.</b> Same functionality as CODE_RUN_SYS.
3	Reserved	<b>Reserved.</b>
2	BOOT_FAIL_SYS	<b>Boot Loading Process Failed.</b> This is an information flag, independent of the BOOT_DONE_SYS. This bit is set when the boot status XDATA variable <b>bBoot_BootStat</b> is not equal to 0x00, signaling error during boot. It is recommended that the user code reads this bit and possibly make decisions whether to continue with the execution of the loaded RAM code, which might not be complete, or signal to a user a problem, by, for example, blinking LED in some not-ordinary fashion.
1	BOOT_DONE_SYS	<b>Boot Routine Finished Flag.</b> Always set to 1 at the end of the boot.
0	CODE_RUN_SYS	<b>Run User Code in RAM.</b> Used for Factory and User program states, ignored in Run state. When this bit is set the boot routine will jump to CODE address 0x0000. Forced by the debugging chain if the device is connected to the IDE.



## 24.9. Boot Routine Destination Address Space

The boot process reads the formatted data from NVM and writes it to the desired destination. The format supports different address regions based on the destination (write) address. The destination address is part of the NVM content data frame format.

Boot routine view of the CPU memory space for writing  
User data from the NVM to the RAM/register spaces

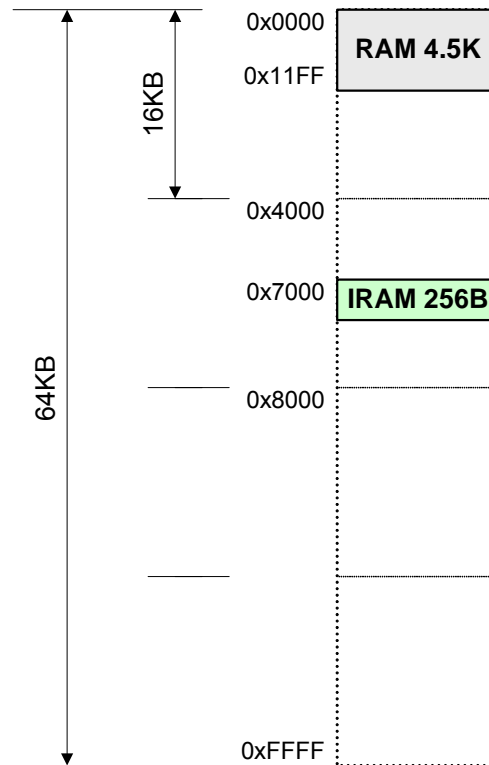

**Figure 24.3. Boot Routine Destination CPU Address Space for Copy from NVM**

The address space of the NVM image destinations depend on the program level of the chip and is shown in Figure 24.3:

- 0x0000 .. 0x11FF .. CODE/XDATA RAM. The end of the RAM is reserved for the boot control data.
- 0x7000 .. 0x70FF .. virtually mapped 256 byte of IRAM for DATA/IDATA indirect access. Whenever the destination address in the NVM image is in this region the data destination is going to be DATA/IDATA IRAM space. However, only region 0x7020 .. 0x70EF is writable. That means that the first 32 and last 16 bytes of the IRAM are not writable by a boot process. Note that the mapping is for indirect internal IRAM access (DATA/IDATA), so SFR registers cannot be initialized by this process.

It is up to the user to generate IntelHEX files to be passed to the NVM programmer. The NVM programmer will ensure that the NVM gets programmed with a proper data structures such that the data values provided in the IntelHEX files will appear at the RAM and IRAM addresses specified in the IntelHEX input file after the boot is done.

# Si4010-C2

---

Note that by using the unified CODE/XDATA memory and by mapping the IRAM to the boot process address space the user can initialize both XDATA and IRAM variables directly from the **User** NVM load without the need for running any startup code to do variable initializations, resulting in the saving of a code size.

One application of the data initialization by a boot process could be copying of keys from the NVM to fixed locations without any code intervention. The user can program all the chips with the same application in the factory and then add only a very small, per chip, User block with keys, specifying where to the XDATA and/or IRAM memories the boot process should copy the values of the keys.

For example, to initialize IRAM location 0x56 to 0xA4 value the user will provide and IntelHEX file specifying that at the address 0x7056 the data value should be 0xA4.

## 24.10. NVM Programming

The user program/data is stored in the NVM memory in a proprietary form; therefore, the NVM programming can be done only by the Silicon Labs provided composer and programmer utility. The data preparer will take user generated application IntelHEX files, user settings (see below), and will generate data to be programmed into the NVM. The NVM programmer then programs the data into the NVM.

During the composing/programming process the user will have control of the following:

1. Make **Factory** part a **User** part .. program User data into the NVM
2. Update **User** part .. add additional User data block to the existing User data already in NVM. This process can be done many times as long as there is a space in NVM.
3. Make **User** part a **Run** part .. mark a part as a final mission mode part. When making the part a Run part the user can decide whether the part retest will be allowed and if so, then what protection restrictions the user is going to impose during the retest process.

These steps can be combined into a single programming step. Step 2. is optional and is convenient when part specific data needs to be added later to the NVM load.

To support the NVM programming Silicon Labs provides two utilities:

- **NVM Programming Utility:** The NVM configuration can be easily setup with this Microsoft Windows based GUI. This application contains both the composer and burner functions. Please check the application note AN511:NVM Programming User Guide for details
- **Command Line NVM programming application:** This application can be integrated into the customer's production line. This utility expects a composed NVM content file as an input (created by the NVM Programming Utility). See the corresponding application note for details.

In addition, 3rd party programmer support is available for high-volume production programming. Silicon Labs can also program parts directly for customers for high-volume production. Contact your Silicon Labs representative for more details.

## 24.11. Retest and Retest Configuration

When the part is programmed as a **Run** part, the C2 interface is disabled and nobody can access the part externally. However, Silicon Labs needs to be able to retest the part in case it returns as a failed part from a customer application. Silicon Labs understands that customer may have programmed sensitive information into the NVM which should not be revealed to anybody, not even to Silicon Labs, during the retest process. During the process of making the part a **Run** part the user will have one time option to control the access to the chip during the retest process.

To be able to retest the fully programmed **Run** part, a special sequence of pin values needs to be applied at a particular time during the boot process. Once that sequence is recognized by the part, the boot process loads only the **Factory** region of the NVM and will not load any of the **User** regions from the NVM.

Then *before* the boot process opens the C2 interface for factory retest communication, it consults the user retest protection control flags programmed into the PROT3\_CTRL byte in NVM when the part was made a **Run** part and acts on the values immediately. Only after all the actions prescribed by the flags settings are completed can the chip open for retest communication.

When making a **Run** part, the user can set the following retest protection flags when using the NVM programmer.

Note that if the bits are set into the PROT3\_CTRL NVM byte before the part is programmed as **Run** part (for example, those bits are set when making a **User** part), the settings are ignored. The boot process will monitor these values only after the part is programmed to be the **Run** part.

**Table 24.2. Run Chip Retest Protection Flags: NVM Programmer**

Flag Name	Description
c2_off	<p>Disable the C2 interface for good. No retest possible.</p> <p><b>Warning:</b> When set then the part is locked out, C2 interface is disabled forever, and SiLabs cannot retest the chip. There is no back door to the part. All other settings below are ignored, since they have no effect.</p> <p>This bit is set in PROT0_CTRL.C2_OFF and it corresponds to <b>C2 Disable</b> checkbox on the NVM programmer GUI.</p>
mem_c2_prot	<p>Protect CODE/XDATA and IRAM RAM memories. When set then the boot process clears CODE/XDATA and IRAM RAM's when the <b>Run</b> chip is opened for retest. CODE/XDATA and IRAM RAM's get cleared with 0, excluding the <b>Factory</b> region at the end of CODE/XDATA. The IRAM gets also cleared completely outside of the register bank 0 (bottom 8 registers). This ensures that there is no lingering <b>User</b> code or data values, like keys, in any of the RAM's.</p> <p>This bit is in PROT3_CTRL.MEM_C2_PROT and it corresponds to <b>RAM Clear</b> checkbox on the NVM programmer GUI.</p>

# Si4010-C2

**Table 24.2. Run Chip Retest Protection Flags: NVM Programmer**

Flag Name	Description
mtp_c2_prot	<p>Protect MTP. When set then both Wr and Rd access to MTP is disabled. Forces boot process to set MTP_PROT=1 to disable MTP communication completely. Reading from MTP returns 0x00 values, writing is not possible. Customer may want to set this option if there is a sensitive information written into the MTP EEPROM during the lifetime of the part.</p> <p>This bit is in PROT3_CTRL.MTP_C2_PROT and it corresponds to <b>MTP Disable</b> checkbox on the NVM programmer GUI.</p>
nvm_c2_prot	<p>Protect NVM. When set then both Wr and Rd access to NVM is disabled. It forces boot process to write NVM_PROT=1 at the end of the boot process to disable NVM access. This protects <b>User</b> load in NVM from being read by SiLabs.</p> <p>If this option is used then the SiLabs can still do the following with NVM content during retest:</p> <ol style="list-style-type: none"><li>1. Calculate CRC32 over the <b>Factory</b> region of NVM.</li><li>2. Calculate CRC32 over the user portion of the NVM, which is the whole NVM excluding the <b>Factory</b> region and the last 64 bytes of NVM.</li><li>3. Read the end 64 bytes of the NVM, which is a reserved NVM region for SiLabs use.</li></ol> <p>When this option is set then SiLabs cannot do anything else with NVM during retest.</p> <p>This bit is in PROT3_CTRL.NVM_C2_PROT and it corresponds to <b>NVM Disable</b> checkbox on the NVM programmer GUI.</p>

Once these options are programmed to the part they cannot be undone or changed. Additional setting of these options *after* the part is made a **Run** part is not possible either.

## 24.12. Boot and Retest Protection NVM Control Byte

The boot process monitors the value of an NVM byte called **PROT3\_CTRL**. There is not a corresponding hardware register to this byte. It is a value in the **Factory** region at the beginning of NVM. The register contains **Retest** protection flags described above and modification of the boot for **User** part.

Each bit is write 1 once. Once the bit is programmed it cannot be cleared. The bits are programmable through the checkboxes in the NVM programmer. Once the bit is set, there is no way to monitor the current status of the bit in the PROT3\_CTRL NVM byte on the device.

### NVM Byte Definition 24.3. PROT3\_CTRL

Bit	7	6	5	4	3	2	1	0
<b>Name</b>	NVM_C2_PROT	MTP_C2_PROT	MEM_C2_PROT	BOOT_X-O_ENA	Reserved		USER_CONT	Reserved
<b>Type</b>	W	W	W	W	R		W	R
<b>Reset</b>	0	0	0	0	0x0		0	0

Bit	Name	Function
7	NVM_C2_PROT	<b>NVM Protection (Disable) When Entering Retest Mode.</b> This bit corresponds to <b>NVM Disable</b> checkbox on the NVM programmer GUI.
6	MTP_C2_PROT	<b>MTP Protection (Disable) When Entering Retest Mode.</b> This bit corresponds to <b>MTP Disable</b> checkbox on the NVM programmer GUI.
5	MEM_C2_PROT	<b>RAM Clearing (Content Protection) When Entering Retest Mode.</b> This bit corresponds to <b>RAM Clear</b> checkbox on the NVM programmer GUI.
4	BOOT_XO_ENA	<b>Enable the Crystal Oscillator (XO) at the Beginning of the Boot Process.</b> This is valid in any device programming level, including <b>Factory</b> . Since it can take up to 10ms for the XO to stabilize and about 3.6 ms to load 1 kB of data from NVM to RAM, the user may decide to enable the XO at the beginning of the boot process so the XO will be stabilizing while the device is going through the boot process to save time in the main application.  This bit corresponds to <b>XO Early Enable</b> checkbox on the NVM programmer GUI.
2:3	Reserved	<b>Reserved.</b>
1	USER_CONT	<b>Run the User Code in User Part after Boot Automatically.</b> For <b>User</b> programming level only, has no effect in other programming levels. Normally when the part is programmed as User the user code is loaded from NVM to RAM, but is not executed automatically. If this bit is set, then the user load is executed automatically after boot.  This bit corresponds to <b>Exe User Boot</b> checkbox on the NVM programmer GUI.
0	Reserved	<b>Reserved.</b>

# Si4010-C2

## 24.13. Chip Protection Control Register

The boot process sets the value of the device protection and configuration SFR register, **PROTO\_CTRL**. The user can read the register and check the programming level of the device as well as protections set to control access to the NVM and MTP memories and C2 interface. The register is user writable, but once a value of 1 is written to any of the bits in the register it cannot be written as 0. Only cycling the power to the part clears the bits, but the boot process will set this register again to the value stored in NVM. Protections can only be made stronger, not weaker. Writing to this register does not affect the underlying data located in NVM.

### SFR Definition 24.4. PROTO\_CTRL

Bit	7	6	5	4	3	2	1	0
<b>Name</b>	NVM_PROT	C2_OFF	Reserved	MTP_PROT	NVM_WR_PROT	NVM_BLOWN[2:0]		
<b>Type</b>	R/W	R/W	R	R/W	R/W	R/W	R/W	R/W
<b>Reset</b>	0	0	1	0	0	0	0	0

SFR Address = 0xDA

Bit	Name	Function
7	NVM_PROT	<b>NVM Protection.</b> Disable NVM access completely. Neither read nor write to NVM is possible. Write 1 sets the bit, write 0 has no effect.
6	C2_OFF	<b>C2 Interface Disable.</b> Write 1 sets the bit, write 0 has no effect. This bit is reset by the main digital power on reset. Power has to be cycled to reset this bit or chip has to wake up from shutdown. If C2 is disabled then the chip is not accessible by a debug chain and not available for retest.
5	Reserved	<b>Reserved.</b>
4	MTP_PROT	<b>MTP Protection.</b> Disable MTP access. If set then MTP will be completely disabled. All reads from MTP will be 0x00. Write 1 sets the bit, write 0 has no effect.
3	NVM_WR_PROT	<b>NVM Write Protection.</b> If this bit is set the NVM is write protected. However, the value is used only if the chip program level is <b>Run</b> , NVM_BLOWN=3'b11x. In all other cases the value of this bit is ignored.
2:0	NVM_BLOWN [2:0]	<b>Displays Chip Program Level.</b> The bits can only be set to 1, write 0 has no effect: 001 .. <b>Factory</b> 011 .. <b>User</b> 111 .. <b>Run</b>

## 25. On-Chip Registers

There are two register regions on chip:

- Special Function Registers region
- XREG region

### 25.1. Special Function Registers

The direct-access data memory locations from 0x80 to 0xFF constitute the special function registers (SFRs). The SFRs provide control and data exchange with the Si4010-C2's resources and peripherals. The CIP-51 controller core duplicates the SFRs found in a typical 8051 implementation as well as implementing additional SFRs used to configure and access the sub-systems unique to the Si4010-C2. This allows the addition of new functionality while retaining compatibility with the MCS-51™ instruction set. Table 25.2 lists the SFRs implemented in the Si4010-C2 device family.

The SFR registers are accessed anytime the direct addressing mode is used to access memory locations from 0x80 to 0xFF. SFRs with addresses ending in 0x0 or 0x8 (e.g. P0, P1, ACC, IE, etc.) are bit-addressable as well as byte-addressable. All other SFRs are byte-addressable only. Unoccupied addresses in the SFR space are reserved for future use. Accessing these areas will have an indeterminate effect and should be avoided. Refer to the corresponding pages of the data sheet, as indicated in Table 25.2, for a detailed description of each register.

**Table 25.1. Special Function Register (SFR) Memory Map**

	0x80	0x90	0xA0	0xB0	0xC0	0xD0	0xE0	0xF0
0*	P0*	P1*	P2*			PSW*	ACC*	B*
1	SP			GPR_CTRL				
2	DPL			GPR_DATA				
3	DPH							
4	GFM_DATA		P0CON				LC_FSK	
5	GFM_CONST		P1CON	PORT_CTRL				
6	SBOX_DATA			PORT_SET			EIE1	EIP1
7	PCON			PORT_INTCFG				
8*			IE*	IP*	TMR2CTRL*			
9		RBIT_DATA	ODS_CTRL	TMR3CTRL	TMR_CLKSEL			
A			ODS_TIMING	TMR3RL	TMR2RL	PROTO_CTRL		
B		FC_CTRL	ODS_DATA	TMR3RH	TMR2RH			
C		RTC_CTRL	ODS_RATEL	TMR3L	TMR2L			
D		FC_INTERVAL	ODS_RATEH	TMR3H	TMR2H	BOOT_FLAGS		
E			ODS_WARM1	SYSGEN	PA_LVL		SYS_SET	
F	CLKOUT_SET		ODS_WARMS2	INT_FLAGS				

\*Notes: Bit addressable registers.

**Table 25.2. Special Function Registers**

SFRs are listed in alphabetical order. All undefined SFR locations are reserved

Register	Address	Description	Page
<b>ACC</b>	0xE0	Accumulator	62
<b>B</b>	0xF0	B Register	63
<b>BOOT_FLAGS</b>	0xDD	Boot Flags	78
<b>CLKOUT_SET</b>	0x8F	Clock Output Settings	124
<b>DPH</b>	0x83	Data Pointer High	61
<b>DPL</b>	0x82	Data Pointer Low	61
<b>EIE1</b>	0xE6	Extended Interrupt Enable 1	96
<b>EIP1</b>	0xF6	Extended Interrupt Priority 1	97
<b>FC_CTRL</b>	0x9B	Frequency Counter Control	52
<b>FC_INTERVAL</b>	0x9D	Frequency Counter Interval	53
<b>GFM_CONST</b>	0x85	AES GFM Multiplier Constant	104
<b>GFM_DATA</b>	0x84	AES GFM Data	104
<b>GPR_CTRL</b>	0xB1	General Purpose Control Register	126
<b>GPR_DATA</b>	0xB2	General Purpose Data Register	126
<b>IE</b>	0xA8	Interrupt Enable	94
<b>IP</b>	0xB8	Interrupt Priority	95
<b>INT_FLAGS</b>	0xBF	Interrupt Flags	98
<b>LC_FSK</b>	0xE4	LC FSK Deviation	46
<b>ODS_CTRL</b>	0xA9	ODS Control	41
<b>ODS_DATA</b>	0xAB	ODS Data	43
<b>ODS_RATEH</b>	0xAD	ODS Rate High Byte	44
<b>ODS_RATEL</b>	0xAC	ODS Rate Low Byte	43
<b>ODS_TIMING</b>	0xAA	ODS Timing Register	42
<b>ODS_WARM1</b>	0xAE	ODS Warm up times for PA and Divider	44
<b>ODS_WARM2</b>	0xAF	ODS Warm up time for LCOSC	45
<b>P0</b>	0x80	Port 0 Latch	118
<b>P0CON</b>	0xA4	Port 0 Configuration	119
<b>P1</b>	0x90	Port 1 Latch	119
<b>P1CON</b>	0xA5	Port 1 Configuration	120
<b>P2</b>	0xA0	Port 2 Latch	120
<b>PA_LVL</b>	0xCE	Power Amplifier Level	38
<b>PCON</b>	0x87	Power Control	102
<b>PORT_CTRL</b>	0xB5	Port Control	121



**Table 25.2. Special Function Registers (Continued)**

SFRs are listed in alphabetical order. All undefined SFR locations are reserved

Register	Address	Description	Page
PORT_INTCFG	0xB7	Port Interrupt Configuration	100
PORT_SET	0xB6	Port Set	122
PROT0_CTRL	0xDA	Protection 0 Control	84
PSW	0xD0	Program Status Word	64
RBIT_DATA	0x99	Read Bit Data	127
RTC_CTRL	0x9C	Real Time Clock Control	130
SBOX_DATA	0x86	AES SBOX Data	105
SP	0x81	Stack Pointer	62
SYSGEN	0xBE	System Generator Register	48
SYS_SET	0xEE	System Setup Register	105
TMR2CTRL	0xC8	Timer/Counter 2 Control	140
TMR2H	0xCD	Timer/Counter 2 High	143
TMR2L	0xCC	Timer/Counter 2 Low	143
TMR2RH	0xCB	Timer/Counter 2 Reload High	142
TMR2RL	0xCA	Timer/Counter 2 Reload Low	142
TMR3CTRL	0x91	Timer/Counter 3 Control	144
TMR3H	0x95	Timer/Counter 3 High	147
TMR3L	0x94	Timer/Counter 3 Low	147
TMR3RH	0x93	Timer/Counter 3 Reload High	147
TMR3RL	0x92	Timer/Counter 3 Reload Low	146
TMR_CLKSEL	0xC9	Timer Source Clock Selection	139

## 25.2. XREG Registers

The chip contains another set of registers implemented in the **XREG** memory area. These registers are located in the XDATA address space, addressable by MOVX instructions only. From CPU perspective it is a regular external memory.

The advantage of the XREG registers is that they are viewed by the CPU as a regular memory. Therefore, they can be declared as different data types, structures, array of bytes, and so on. With SFR we only have special registers and it is not possible to declare them as long integers, for example. On the other hand the SFR register access is faster and one can use arithmetic and logical operations on them.

Note registers in the XREG regions are aligned at 8, 16, and 32 bit boundaries and they are stored in **big** endian fashion. This is to support Keil C compiler, which uses **big endian**. Note that if the register is, say 23 bits wide, the 32 bits (4 bytes) are allocated for the register and the register is aligned in big endian fashion.

Therefore, the LSB byte of the register will be at the address  $\langle reg\_addr \rangle + 3$ , while the byte directly at the  $\langle reg\_addr \rangle$  is the MSB byte and is empty (read as 0x0), since the register itself is only 23 bits wide. Table 25.3 shows a memory map of the XREG registers in the external memory space.

Table 25.3. XREG Register Memory Map in External Memory

XDATA Address	Type	Name	Byte Order
0x4002	BYTE	bLPOSC_TRIM	
0x4003 ... 0x4007		<reserved>	
0x4008 0x4009 0x400a 0x400b	LWORD	IFC_COUNT	MSB Byte
0x400c 0x400d	WORD	wPA_CAP	LSB Byte MSB Byte LSB Byte
0x400e ... 0x4011		<reserved>	
0x4012	BYTE	bPA_TRIM	
0x4013 ... 0x4015		<reserved>	
0x4016	BYTE	bXO_CTRL	
0x4017	BYTE	bPORT_TST	
0x4018 ... 0x4026		<reserved>	
0x4040 ... 0x404f	BYTE	abMTP_RDATA[16]	Byte [0]  Byte [15]
<p><b>Note:</b> Multiple byte variables, if they are not arrays, are stored in <b>big endian</b> .. MSB byte stored on lower address. Arrays are stored with byte index [0] at lower address.</p>			

**Table 25.4. XREG Registers**

XREGs are listed in alphabetical order.

Register	Address	Description	Page
<b>IFC_COUNT</b>	0x4008	Frequency Counter Output	53
<b>bLPOSC_TRIM</b>	0x4002	Low Power Oscillator Trim	47
<b>abMTP_RDATA[16]</b>	0X4040	MTP_Read Data Bytes	68
<b>wPA_CAP</b>	0x400C	PA Variable Capacitor	38
<b>bPA_TRIM</b>	0x4012	PA MAX Drive bit	39
<b>bXO_CTRL</b>	0x4016	XO Control	49

Description of the XREG register fields on the previous pages includes only the used register bits. The fields are aligned towards the LSB byte of the XREG register. If the actual XREG register is wider then the field described the missing bits towards MSB byte are all read as 0's and writing to them has no effect. For example, the register **wPA\_CAP** contains a single 9 bit field. Since it is more than 8 bits and less then 16 it occupies two bytes. That's why the prefix letter 'w' denoting a two byte WORD. The bits [15:9] are read as all zeros and write has no effect. They are aligned towards MSB byte of the **wPA\_CAP**, the one at lower address since the byte ordering is in big endian fashion.

## 26. Interrupts

The Si4010 device includes an extended interrupt system supporting a total of 12 interrupt sources with two priority levels. Each interrupt source has one or more associated interrupt-pending flag(s) located in an SFR. When a peripheral or external source meets a valid interrupt condition, the associated interrupt-pending flag is set to logic '1'.

If interrupts are enabled for the source, an interrupt request is generated when the interrupt-pending flag is set. As soon as execution of the current instruction is complete, the CPU generates an LCALL to a predetermined address to begin execution of an interrupt service routine (ISR). Each ISR must end with an RETI instruction, which returns program execution to the next instruction that would have been executed if the interrupt request had not occurred. If interrupts are not enabled, the interrupt-pending flag is ignored by the hardware and program execution continues as normal. The interrupt-pending flag is set to logic '1' regardless of the interrupt's enable/disable state.

Each interrupt source can be individually enabled or disabled through the use of an associated interrupt enable bit in the Interrupt Enable and Extended Interrupt Enable SFRs. However, interrupts must first be globally enabled by setting the EA bit (IE.7) to logic '1' before the individual interrupt enables are recognized.

Setting the EA bit to logic '0' disables all interrupt sources regardless of the individual interrupt-enable settings. Note that interrupts which occur when the EA bit is set to logic '0' will be held in a pending state, and will not be serviced until the EA bit is set back to logic '1'.

**Note:** Any instruction that clears a bit to disable an interrupt should be immediately followed by an instruction that has two or more opcode bytes. Using EA (global interrupt enable) as an example:

```
// in 'C':
EA = 0; // clear EA bit.
EA = 0; // this is a dummy instruction with two-byte opcode.

; in assembly:
CLR EA ; clear EA bit.
CLR EA ; this is a dummy instruction with two-byte opcode.
```

For example, if an interrupt is posted during the execution phase of a "CLR EA" opcode (or any instruction which clears a bit to disable an interrupt source), and the instruction is followed by a single-cycle instruction, the interrupt may be taken. However, a read of the enable bit will return a '0' inside the interrupt service routine. When the bit-clearing opcode is followed by a multi-cycle instruction, the interrupt will not be taken.

On this device no interrupt-pending flags are automatically cleared by the hardware when the CPU vectors to the ISR. The flags must be cleared by software before returning from the ISR. If an interrupt-pending flag remains set after the CPU completes the return-from-interrupt (RETI) instruction, a new interrupt request will be generated immediately and the CPU will re-enter the ISR after the completion of the next instruction.

# Si4010-C2

---

## 26.1. MCU Interrupt Sources and Vectors

The device supports 12 interrupt sources. Software can simulate an interrupt by setting any interrupt-pending flag to logic '1'. If interrupts are enabled for the flag, an interrupt request will be generated and the CPU will vector to the ISR address associated with the interrupt-pending flag. MCU interrupt sources, associated vector addresses, priority order, and control bits are summarized in Table 26.1. Refer to the data sheet section associated with a particular on-chip peripheral for information regarding valid interrupt conditions for the peripheral and the behavior of its interrupt-pending flag(s).

## 26.2. Interrupt Priorities

Each interrupt source can be individually programmed to one of two priority levels: low or high. A low priority interrupt service routine can be preempted by a high priority interrupt. A high priority interrupt cannot be preempted. Each interrupt has an associated interrupt priority bit in an SFR (IP or EIP1) used to configure its priority level. Low priority is the default. If two interrupts are recognized simultaneously, the interrupt with the higher priority is serviced first. If both interrupts have the same priority level, a fixed priority order is used to arbitrate, given in Table 26.1.

## 26.3. Interrupt Latency

Interrupt response time depends on the state of the CPU when the interrupt occurs. Pending interrupts are sampled and priority decoded each system clock cycle. Therefore, the fastest possible response time is 5 system clock cycles: 1 clock cycle to detect the interrupt and 4 clock cycles to complete the LCALL to the ISR. Additional clock cycles will be required if a chance miss occurs. If an interrupt is pending when a RETI is executed, a single instruction is executed before an LCALL is made to service the pending interrupt. Therefore, the maximum response time for an interrupt (when no other interrupt is currently being serviced or the new interrupt is of greater priority) is when the CPU is performing an RETI instruction followed by a DIV as the next instruction. If the CPU is executing an ISR for an interrupt with equal or higher priority, the new interrupt will not be serviced until the current ISR completes, including the RETI and following instruction.

Table 26.1. Interrupt Summary

Interrupt Source	Interrupt Vector	Priority Order	Pending Flag	Bit addressable?	Enable Flag	Priority Control
Reset	0x0000	Top	None	N/A	Always Enabled	Always Highest
External INT 0 (INT0)	0x0003	0	INT0_FLAG (INT_FLAGS.0)	N	EINT0 (IE.0)	PINT0 (IP.0)
Timer 2 Overflow	0x000B	1	TMR2INTL (TMR2CTRL.6) TMR2INTH (TMR2CTRL.7)	Y	ETMR2 (IE.1)	PTMR2 (IP.1)
Temp Sensor DMD	0x0013	2	DMD_NEW (DMD_CTRL.3)	N	EDMD (IE.2)	PDMD (IP.2)
Real Time Clock Tick	0x001B	3	RTC_INT (RTC_CTRL.7)	N	ERTC (IE.3)	PRTC (IP.3)
ODS Ready for Data	0x0023	4	ODS_FLAG (INT_FLAGS.2)	N	EODS (IE.4)	PODS (IP.4)
Timer 3 Overflow	0x002B	5	TMR3INTL (TMR3CTRL.6) TMR3INTH (TMR3CTRL.7)	N	ETMR3 (IE.5)	PTMR3 (IP.5)
External INT1	0x0033	6	INT1_FLAG (INT_FLAGS.1)	N	EINT1 (IE.6)	PINT1 (IP.6)
Reserved	0x003B	7	N/A	N/A	N/A	N/A
Reserved	0x0043	8	N/A	N/A	N/A	N/A
Frequency Counter Count Done	0x004B	9	FC_DONE (FC_CTRL.7)	N	EFC (EIE1.2)	PFC (EIP1.2)
Software Source 0 (can be used for software generated interrupts)	0x0053	10	VOID0_FLAG (INT_FLAGS.3)	N	EVOID0 (EIE1.3)	PVOID0 (EIP1.3)
Software Source 1 (can be used for software generated interrupts)	0x005B	11	VOID1_FLAG (INT_FLAGS.4)	N	EVOID1 (EIE1.4)	PVOID1 (EIP1.4)

## 26.4. Interrupt Register Descriptions

The SFRs used to enable the interrupt sources and set their priority level are described in this section. Refer to the data sheet section associated with a particular on-chip peripheral for information regarding valid interrupt conditions for the peripheral and the behavior of its interrupt-pending flag(s).

# Si4010-C2

## SFR Definition 26.1. IE

Bit	7	6	5	4	3	2	1	0
Name	EA	EINT1	ETMR3	EODS	ERTC	EDMD	ETMR2	EINT0
Type	R/W	R/W	R/W	R/W	R/W	R/W	R/W	R/W
Reset	0	0	0	0	0	0	0	0

SFR Address = 0xA8; Bit-Addressable

Bit	Name	Function
7	EA	<b>Enable All Interrupts.</b> Globally enables/disables all interrupts. It overrides individual interrupt mask settings. 0: Disable all interrupt sources. 1: Enable each interrupt according to its individual mask setting.
6	EINT1	<b>Enable External Edge Interrupt 1.</b> This bit sets the masking of External Interrupt 1. 0: Disable external interrupt 1. 1: Enable interrupt requests generated by the INT1 input.
5	ETMR3	<b>Enable Timer 3 Interrupt.</b> This bit sets the masking of the Timer 3 interrupt. 0: Disable Timer 3 interrupt. 1: Enable interrupt requests generated by the TF3L or TF3H flags.
4	EODS	<b>Enable Output Data Serializer Interrupt.</b> This bit sets the masking of the ODS interrupt. 0: Disable ODS interrupt. 1: Enable ODS interrupt.
3	ERTC	<b>Enable Real Time Clock Interrupt.</b> This bit sets the masking of the RTC interrupt. 0: Disable all RTC interrupt. 1: Enable RTC interrupt.
2	EDMD	<b>Enable DMD (TS Demodulator).</b> This bit sets the masking of the DMD interrupt. 0: Disable DMD interrupt. 1: Enable DMD interrupt.
1	ETMR2	<b>Enable Timer 2 Interrupt.</b> This bit sets the masking of the Timer 2 interrupt. 0: Disable all Timer 2 interrupt. 1: Enable interrupt requests generated by the TF2 flag.
0	EINT0	<b>Enable External Edge Interrupt 0.</b> This bit sets the masking of External Interrupt 0. 0: Disable external interrupt 0. 1: Enable interrupt requests generated by the INT0 input.



---

**SFR Definition 26.2. IP**

---

Bit	7	6	5	4	3	2	1	0
<b>Name</b>	Reserved	PINT1	PTMR3	PODS	PRTC	PDMD	PTMR2	PINT0
<b>Type</b>	R/W	R/W	R/W	R/W	R/W	R/W	R/W	R/W
<b>Reset</b>	1	0	0	0	0	0	0	0

SFR Address = 0xB8; Bit-Addressable

Bit	Name	Function
7	Reserved	Read = 1, Write = Don't Care.
6	PINT1	<b>External Edge Interrupt 1 Priority Control.</b> This bit sets the priority of the External Interrupt 1 interrupt. 0: External Interrupt 1 set to low priority level. 1: External Interrupt 1 set to high priority level.
5	PTMR3	<b>Timer 3 Interrupt Priority Control.</b> This bit sets the priority of the Timer 3 interrupt. 0: Timer 3 interrupt set to low priority level. 1: Timer 3 interrupt set to high priority level.
4	PODS	<b>Output Data Serializer Interrupt Priority Control.</b> This bit sets the priority of the ODS interrupt. 0: ODS interrupt set to low priority level. 1: ODS interrupt set to high priority level.
3	PRTC	<b>Real Time Clock Interrupt Priority Control.</b> This bit sets the priority of the RTC interrupt. 0: RTC interrupt set to low priority level. 1: RTC interrupt set to high priority level.
2	PDMD	<b>DMD (TS demodulator) Interrupt Priority Control.</b> This bit sets the priority of the DMD interrupt. 0: DMD interrupt set to lower priority. 1: DMD interrupt set to higher priority.
1	PTMR2	<b>Timer 2 Interrupt Priority Control.</b> This bit sets the priority of the Timer 2 interrupt. 0: Timer 2 interrupt set to low priority level. 1: Timer 2 interrupt set to high priority level.
0	PINT0	<b>External Edge Interrupt 0 Priority Control.</b> This bit sets the priority of the External Interrupt 0 interrupt. 0: External Interrupt 0 set to low priority level. 1: External Interrupt 0 set to high priority level.

# Si4010-C2

---

## SFR Definition 26.3. EIE1

---

Bit	7	6	5	4	3	2	1	0
Name	Reserved	Reserved	Reserved	EVOID1	EVOID0	EFC	Reserved	Reserved
Type	R	R	R	R/W	R/W	R/W	R	R
Reset	0	0	0	0	0	0	0	0

SFR Address = 0xE6

Bit	Name	Function
7:5	Reserved	Read as 0x0. Write has no effect.
4	EVOID1	<b>Enable VOID1 Interrupt (Reserved).</b> This bit sets the VOID1 interrupt.(Reserved) 0: Disable VOID1 interrupts. 1: Enable interrupt requests generated by VOID1 flags (Reserved).
3	EVOID0	<b>Enable VOID0 Interrupt (Reserved).</b> This bit sets the VOID0 interrupt.(Reserved) 0: Disable VOID0 interrupts. 1: Enable interrupt requests generated by VOID0 flags (Reserved).
2	EFC	<b>Enable Frequency Counter Interrupt.</b> This bit sets the Frequency Counter interrupt. 0: Disable Frequency Counter interrupt. 1: Enable interrupt requests generated by Frequency Counter.
1:0	Reserved	Reset value 0x0 must not be changed.

---

**SFR Definition 26.4. EIP1**

---

Bit	7	6	5	4	3	2	1	0
<b>Name</b>	Reserved			PVOID1	PVOID0	PFC	Reserved	
<b>Type</b>	R			R/W	R/W	R/W	R/W	
<b>Reset</b>	0			0	0	0	0	

SFR Address = 0xF6

Bit	Name	Function
7:5	Reserved	Read as 0x0. Write has no effect.
4	PVOID1	<b>VOID1 Interrupt Priority Control.</b> This bit sets the priority of the VOID1 interrupt. 0: VOID1 interrupt set to low priority level. 1: VOID1 interrupt set to high priority level.
3	PVOID0	<b>VOID0 Interrupt Priority Control.</b> This bit sets the priority of the VOID0 interrupt. 0: VOID0 interrupt set to low priority level. 1: VOID0 interrupt set to high priority level.
2	PFC	<b>Frequency Counter Interrupt Priority Control.</b> This bit sets the priority of the Frequency Counter interrupt. 0: Frequency Counter interrupt set to low priority level. 1: Frequency Counter interrupt set to high priority level.
1:0	Reserved	Reset value 0x0 must not be changed.

# Si4010-C2

## SFR Definition 26.5. INT\_FLAGS

Bit	7	6	5	4	3	2	1	0
Name	Reserved	Reserved	Reserved	VOID1_FLAG	VOID0_FLAG	ODS_FLAG	INT1_FLAG	INT0_FLAG
Type	R	R	R	R/W	R/W	R/W	R/W	R/W
Reset	0	0	0	0	0	0	0	0

SFR Address = 0xBF

Bit	Name	Function
7:5	Reserved	Read as 0x0. Write has no effect.
4	VOID1_FLAG	<b>Spare Interrupt Flag (can be used freely by the user application software).</b> Interrupt can be invoked by software only by writing 1 here.
3	VOID0_FLAG	<b>Spare Interrupt Flag (can be used freely by the user application software).</b> Interrupt can be invoked by software only by writing 1 here.
2	ODS_FLAG	<b>Set when TX Data Holding Register becomes Empty.</b> It must be cleared by software BEFORE writing a new byte into the ODS Tx data register. Hardware will not clear this bit.
1	INT1_FLAG	<b>Set by Selected GPIO Input by a Selected Edge.</b> It gets set irrespective of the EINT0 setting. It must be cleared by software. Hardware will not clear this bit.
0	INT0_FLAG	<b>Set by Selected GPIO Input by a Selected Edge.</b> It gets set irrespective of the EINT0 setting. It must be cleared by software. Hardware will not clear this bit.

## 26.5. External Interrupts

The INT0 and INT1 external interrupt sources are configurable as active high or low. They are edge sensitive only, not level sensitive. These are not the same INT0 and INT1 as found on original 8051 architecture.

Each of the INT0 and INT1 can invoke interrupt on the rising edge, falling edge, or both edges of the selected GPIO pins associated with the INT0 and INT1, respectively.

The single edge or double edge feature is controlled by the EDGE\_INT0 and EDGE\_INT1 bits in the PORT\_SET register. The edge polarity is defined in the PORT\_INTCFG register.

INT0 and INT1 are assigned to Port pins as defined in the PORT\_INTCFG register. Note that the corresponding pending flag for INT0 or INT1 is **not** automatically cleared by the hardware when the CPU vectors to the ISR. This is a departure from the original 8051 architecture where if external interrupts were configured to be edge sensitive the corresponding interrupt flag was cleared by hardware upon the exit from the ISR routine.

The detection of the edges of INT0 and INT1 sources is done by sampling the associated port inputs by the internal system clock. Therefore, the edge detector will miss pulses shorter than 2 periods of the internal system clock periods. Note that the internal system clock frequency is programmable and can be as low as 24 MHz/128. It is up to the user to recognize possible external interrupt delays associated with sampling of the INT0 and INT1 by the system clock at the current, user selected, clock frequency.

The INT1 and INT0 internal signals are also used as capture event signals for timer 3 and 2, respectively, if they are running in capture mode.

# Si4010-C2

## SFR Definition 26.6. PORT\_INTCFG

Bit	7	6	5	4	3	2	1	0
Name	NEG_INT1	SEL_INT1[2:0]			NEG_INT0	SEL_INT0[2:0]		
Type	R/W	R/W			R/W	R/W		
Reset	0	0	0	0	0	0	0	0

SFR Address = 0xB7

Bit	Name	Function
7	NEG_INT1	<p><b>Negative INT1 Polarity.</b></p> <p>This bit selects whether the selected INT1 GPIO input will get inverted or pass as is before going to the edge detector. Note the edge detector detects either the rising edge or both. The mode is selectable by EDGE_INT1 bit is separate register.</p> <p>0: Pass the selected GPIO unchanged.</p> <p>1: Inverts the selected GPIO.</p>
6:4	SEL_INT1[2:0]	<p><b>INT1 Port Pin Selection Bits.</b></p> <p>These bits select which Port pin is assigned to INT1.</p> <p>000: Select GPIO0</p> <p>001: Select GPIO1</p> <p>010: Select GPIO2</p> <p>011: Select GPIO3</p> <p>100: Select GPIO4</p> <p>101: Select <b>GPIO9</b></p> <p>110: Select GPIO6</p> <p>111: Select GPIO7</p>
3	NEG_INT0	<p><b>Negative INT0 Polarity.</b></p> <p>This bit selects whether the selected INT0 GPIO input will get inverted or pass as is before going to the edge detector. Note the edge detector detects either the rising edge or both. The mode is selectable by EDGE_INT0 bit is separate register.</p> <p>0: Pass the selected GPIO unchanged.</p> <p>1: Inverts the selected GPIO.</p>
2:0	SEL_INT0[2:0]	<p><b>INT0 Port Pin Selection Bits.</b></p> <p>These bits select which Port pin is assigned to INT0.</p> <p>000: Select GPIO0</p> <p>001: Select GPIO1</p> <p>010: Select GPIO2</p> <p>011: Select GPIO3</p> <p>100: Select GPIO4</p> <p>101: Select <b>GPIO8</b></p> <p>110: Select GPIO6</p> <p>111: Select GPIO7</p>

## 27. Power Management Modes

The CIP-51 core has two software programmable power management modes: **Idle** and **Stop**. **Idle** mode halts the CPU while leaving the external peripherals and internal clocks active. In **Stop** mode, the CPU is halted, all interrupts and timers are inactive. The system clock is still running when the CPU is in **Stop** mode. Since clocks are running, power consumption is dependent upon the system clock frequency and the number of peripherals left in active mode before entering **Idle** or **Stop**. See the SFR definition of the Power Control Register (PCON) used to control the CPU power management modes.

Although the CIP-51 has **Idle** and **Stop** modes built in (as with any standard 8051 architecture), power management of the entire MCU is better accomplished by enabling/disabling individual peripherals as needed. Each analog peripheral can be disabled when not in use and put into low power mode. Digital peripherals, such as timers, draw little power whenever they are not in use.

The devices feature an additional shutdown mode, which shuts the device down. The device then can be woken up by pulling GPIO input to ground. See other sections for details.

### 27.1. Idle Mode

Setting the Idle Mode Select bit (PCON.0) causes the CIP-51 to halt the CPU and enter **Idle** mode as soon as the instruction that sets the bit completes. All internal registers and memory maintain their original data. All analog and digital peripherals can remain active during **Idle** mode.

**Idle** mode is terminated when an enabled interrupt or reset is asserted. The assertion of an enabled interrupt will cause the Idle Mode Selection bit (PCON.0) to be cleared and the CPU to resume operation. The pending interrupt will be serviced and the next instruction to be executed after the return from interrupt (RETI) will be the instruction immediately following the one that set the Idle Mode Select bit. If **Idle** mode is terminated by an external reset, the CIP-51 performs a normal reset sequence.

**Note:** Any instruction which sets the IDLE bit should be immediately followed by an instruction which has two or more opcode bytes. For example:

In C:

```
PCON |= 0x01; // Set IDLE bit
PCON = PCON; // ... Followed by a 3-cycle Dummy Instruction;
```

In assembly:

```
ORL PCON, #01h ; Set IDLE bit
MOV PCON, PCON ; ... Followed by a 3-cycle Dummy Instruction
```

If the instruction following the write to the IDLE bit is a single-byte instruction and an interrupt occurs during the execution of the instruction which sets the IDLE bit, the CPU may not wake from IDLE mode when a future interrupt occurs.

### 27.2. Stop Mode

Setting the Stop Mode Select bit (PCON.1) causes the CIP-51 to enter **Stop** mode as soon as the instruction that sets the bit completes. In **Stop** mode, the CPU is stopped, effectively shutting down all digital peripherals. Each analog peripheral must be shut down individually prior to entering **Stop** mode. **Stop** mode can only be terminated by an external reset. On reset, the CIP-51 performs the normal reset sequence and begins program execution based on the program level of the chip.

The system clock is not stopped when in **Stop** mode.

# Si4010-C2

---

## SFR Definition 27.1. PCON

---

Bit	7	6	5	4	3	2	1	0
Name	GF[5:0]						STOP	IDLE
Type	R/W						R/W	R/W
Reset	0	0	0	0	0	0	0	0

SFR Address = 0x87

Bit	Name	Function
7:2	GF[5:0]	<b>General Purpose Flags 5–0.</b> These are general purpose flags for use under software control.
1	STOP	<b>Stop Mode Select.</b> Setting this bit will place the CIP-51 in Stop mode. This bit will always be read as 0. 1: CPU goes into Stop mode (internal oscillator stopped).
0	IDLE	<b>Idle Mode Select.</b> Setting this bit will place the CIP-51 in Idle mode. This bit will always be read as 0. 1: CPU goes into Idle mode. (Shuts off clock to CPU, but clock to Timers, Interrupts, Serial Ports, and Analog Peripherals are still active.)



## 28. AES Hardware Accelerator

The device implements the AES (Advanced Encryption Standard) hardware accelerator. It is not a full hardware solution. The hardware accelerator is used by the Silicon Labs API firmware to implement AES 128 bit encrypt/decrypt functions. If the user wants to implement proprietary AES implementation in firmware it is possible to use the AES hardware accelerator.

The accelerator has two parts:

1. AES Galois field (GF) hardware multiplier
2. AES SBox/Inverse SBox hardware module

The Galois field multiplier is designed to multiply two AES Galois field 8-bit elements, even though the AES just multiplies values by a constant. It is up to the firmware to setup the constant and data to multiply.

The hardware implements efficient SBox/Inverse SBox data processing.

Consult the AES standard for details.

### 28.1. AES SFR Registers

There are three SFR registers associated with the AES accelerator.

To use the GF multiplier the user must first write the GFM\_CONST register. The write is needed only if the user desires to change the previous value in that register. It holds its value until overwritten. To perform the multiply operation the data has to be written to GFM\_DATA register. Writing data to GFM\_DATA register invokes the actual multiply operation. It takes 2 system clock cycles to perform the multiplication and the calculated result appears in the GFM\_DATA register, overwriting the user input data. Therefore, at least a single cycle dummy instruction must be added in between writing the data to be multiplied to the GFM\_DATA register and reading the result from there:

```
mov GFM_DATA, #data    ; Invoke a GF multiply
nop                    ; At least single cycle wait instruction
mov A, GFM_DATA        ; Read the result
```

Usage of the SBox/Inverse SBox hardware is controlled by the AES\_DECRYPT bit in the SYS\_SET register (SYS\_SET.3). For encryption, the SBox operation is selected, for decryption the Inverse SBox operation is selected.

To pass data through the SBox the user has to write the data to the SBOX\_DATA register. Writing data there invokes the conversion operation. The result appears in the SBOX\_DATA register, overwriting the original data. It takes 2 system clock cycles to perform the conversion. Therefore, at least a single cycle dummy instruction must be added in between writing the data to be converted to the SBOX\_DATA register and reading the result from there:

```
mov SBOX_DATA, #data  ; Invoke a SBox conversion
nop                    ; At least single cycle wait instruction
mov A, SBOX_DATA      ; Read the result
```

If the Silicon Labs device API AES implementation is used by the user application, all the AES accelerator communication is handled by the API functions and is hidden from the user.

# Si4010-C2

---

## SFR Definition 28.1. GFM\_DATA

---

Bit	7	6	5	4	3	2	1	0
Name	GFM_DATA[7:0]							
Type	R/W	R/W	R/W	R/W	R/W	R/W	R/W	R/W
Reset	0	0	0	0	0	0	0	0

SFR Address = 0x84

Bit	Name	Function
7:0	GFM_DATA [7:0]	<b>GFM Multiplier Data Processing.</b> Writing of a value here registers the data for processing. Processed data is registered into the same register with single CLK_SYS cycle delay. Read from this register reads the processed multiplied data. The register GFM_CONST must be written before GFM_DATA is written.

---

## SFR Definition 28.2. GFM\_CONST

---

Bit	7	6	5	4	3	2	1	0
Name	GFM_CONST[7:0]							
Type	R/W	R/W	R/W	R/W	R/W	R/W	R/W	R/W
Reset	0	0	0	0	0	0	0	0

SFR Address = 0x85

Bit	Name	Function
7:0	GFM_CONST [7:0]	<b>GFM Multiplier Constant Register.</b> This is the constant by which the GFM_DATA is multiplied by. It has to be written prior to GFM_DATA.

**SFR Definition 28.3. SBOX\_DATA**

Bit	7	6	5	4	3	2	1	0
Name	SBOX_DATA[7:0]							
Type	R/W	R/W	R/W	R/W	R/W	R/W	R/W	R/W
Reset	0	0	0	0	0	0	0	0

SFR Address = 0x86

Bit	Name	Function
7:0	SBOX_DATA [7:0]	<b>AES SBox Processing.</b> Writing of a value here registers the data for processing. Processed data is registered into the same register with single CLK_SYS cycle delay. Read from this register reads the processed data. The type of SBox processing is controlled by AES_DECRYPT bit

**SFR Definition 28.4. SYS\_SET**

Bit	7	6	5	4	3	2	1	0
Name	Reserved	Reserved	Reserved	Reserved	AES_DECRYPT	Reserved	Reserved	Reserved
Type	R/W	R/W	R/W	R/W	R/W	R/W	R/W	R/W
Reset	0	0	0	1	0	0	0	0

SFR Address = 0xEE

Bit	Name	Function
7:5	Reserved	Reserved. Read as 0x0. Write has no effect.
4	Reserved	Reserved. Do not write to this bit.
	AES_DECRYPT	<b>AES SBox Hardware Logic Control.</b> 0: SBox is set for encryption. 1: SBox is set for decryption.
	Reserved	Reserved. Do not change these values.

## 29. Reset Sources

Reset circuitry allows the controller to be easily placed in a predefined default condition. There is only one external reset source for the device, which is power on reset. It gets invoked at two occasions:

1. Power is supplied to the device. This means connecting the power supply to disconnected device or cycling the external power to the device.
2. The device is waking up from a shutdown/standby mode. The power supply was connected before, but the device was put into the shutdown/standby mode. The wake up event can happen because of two reasons:
  - One of the GPIOs is pulled low (e.g., a push button is pressed).
  - The (previously enabled) sleep timer is expired.

On entry to the reset state, the following events occur:

- CIP-51 halts program execution
- Special Function Registers (**SFR**) are initialized to their defined reset values
- XDATA registers (**XREG**) are initialized to their defined reset values
- External Port pins are forced to a known state
- Interrupts and timers are disabled

All SFRs are reset to the predefined values noted in the SFR detailed descriptions. The contents of internal data memory is lost since the power got cycled.

The Port I/O latches are reset to 0xFF (all logic ones) in open-drain mode.

On exit from the reset state, the program counter (PC) is reset, and the system clock defaults to the internal oscillator frequency of 24 MHz. Device starts its startup boot procedure. See other sections for description of the boot procedure. The user code starts being executed only after the boot procedure finishes. See section 24. System Boot and NVM Programming for details.

### 29.1. Device Boot Outline

Since the device does not have flash memory to permanently hold user code, the device has to go through a boot sequence in which the user code is copied from the one time programmable NVM memory to the CODE/XDATA RAM. After that is done the user program execution starts at address 0x0000.

It takes about fixed 2 ms plus about 3.6 ms per 1 kB of user data to be copied from NVM to RAM. When the user puts the device into shutdown mode this will be the estimated time for waking up the chip from shutdown mode by applying any GPIO to ground and the execution of the first instruction of the user code in CODE/XDATA RAM.

For debugging purposes the user will not program the NVM, but will use the RAM for code development. In that case the device will go through much shorter startup routine, which would take less than 2 ms to conclude.

See “24. System Boot and NVM Programming” on page 69 for details.

### 29.2. External Reset

There is no external reset. There is no pin dedicated to the device reset. The Silicon Labs debug chain using USB debug adapter or ToolStick has access to the proprietary reset control on chip to facilitate user code debug and development. During the debugging sessions on unprogrammed part the content of the CODE/XDATA RAM is preserved in between IDE environment invoked resets (**Reset** button inside IDE).

---

## 29.3. Software Reset

There is no traditional software reset on the Si4010, but a similar result can be achieved by setting up the sleep timer and then putting the device into shutdown mode. This action effectively disconnects power to the internal systems of the device. Once the sleep time expires it will wake the Si4010, which will have the same effect as a power on reset to the device creating a software reset. Note that the sleep timer must be programmed and armed before the user puts the devices into shutdown mode.

## 30. Port Input/Output

Digital resources are available through up to 10 I/O pins. The number of I/O depends on the package:

- 10 pin package .. 6 port pins organized as 6 bottom bits of Port 0.
- 14 pin package .. 10 port pins organized as a full 8-bit Port 0 and 2 bottom bits of Port 1.

The package pin assignment is in Figure 30.1.

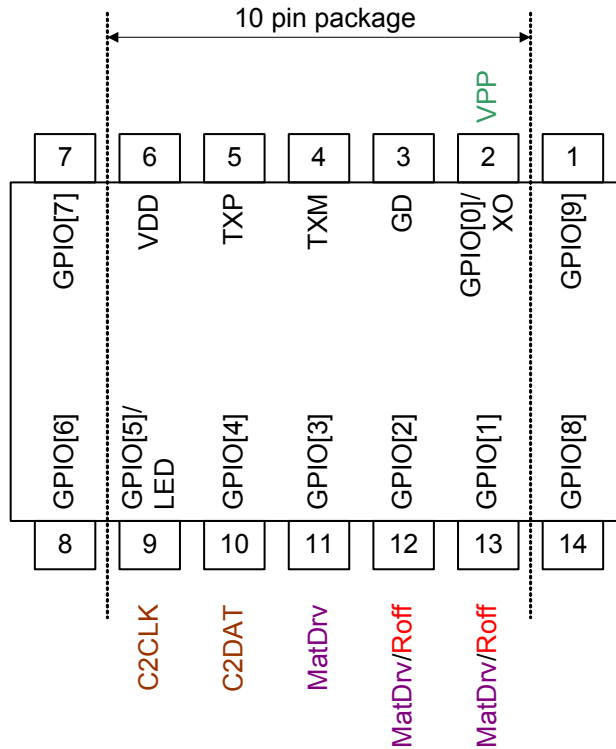

**Figure 30.1. Device Package and Port Assignments**

# Si4010-C2

Pin assignments for 10– and 14–pin packages are shown in Table 30.1 and Table 30.2.

**Table 30.1. 10–Pin Mode**

Package Pin Number	Package Pin Name
1	GPIO0/XO
10	GPIO1
9	GPIO2
8	GPIO3
7	GPIO4
6	GPIO5/LED

**Table 30.2. 14–Pin Mode**

Package Pin Number	Package Pin Name
2	GPIO0/XO
13	GPIO1
12	GPIO2
11	GPIO3
10	GPIO4
9	GPIO5/LED
8	GPIO6
7	GPIO7
14	GPIO8
1	GPIO9

The GPIO Port I/O can be configured as either open-drain or push-pull in SFR registers P0CON and P1CON.

The GPIO functional diagrams and related digital control are in Figure 30.2 and Figure 30.3.

The option for Matrix mode is available only on GPIO[3:1] and the option for Roff mode is available only on GPIO[2:1].

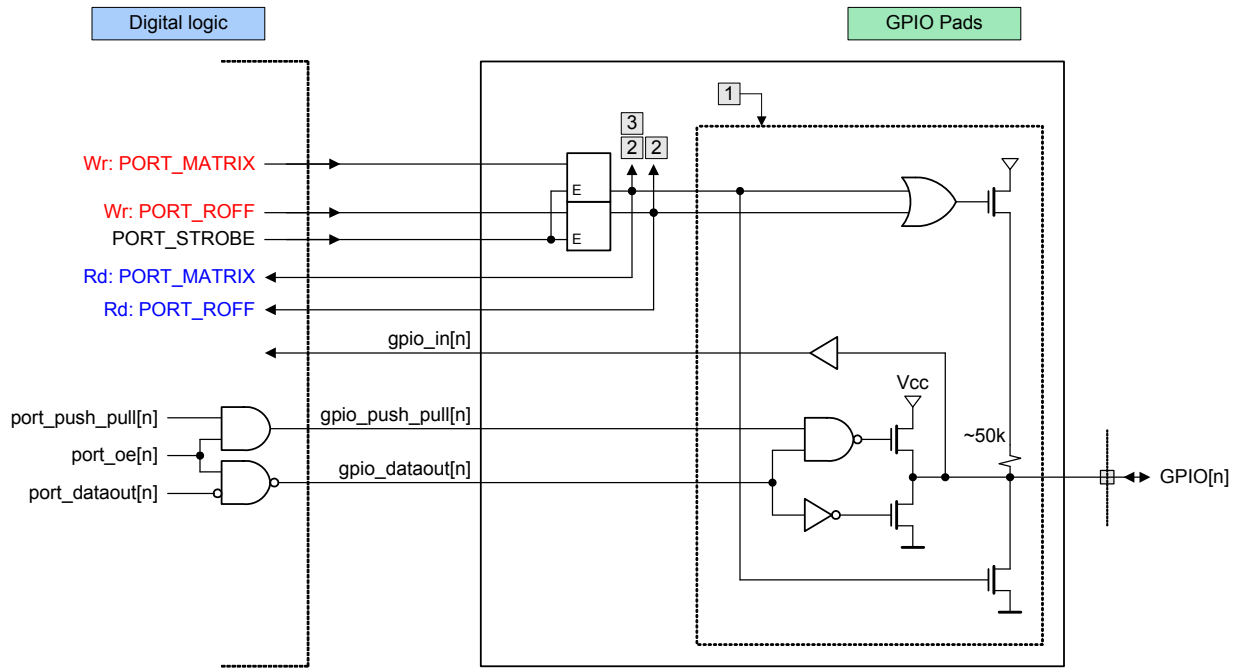

**Figure 30.2. GPIO[3:1] Functional Diagram**

Functional diagram of the other GPIO ports is in Figure 30.3. It is the general GPIO circuit that can be forced by digital control to have limited functionality (e.g., as input only, etc.).

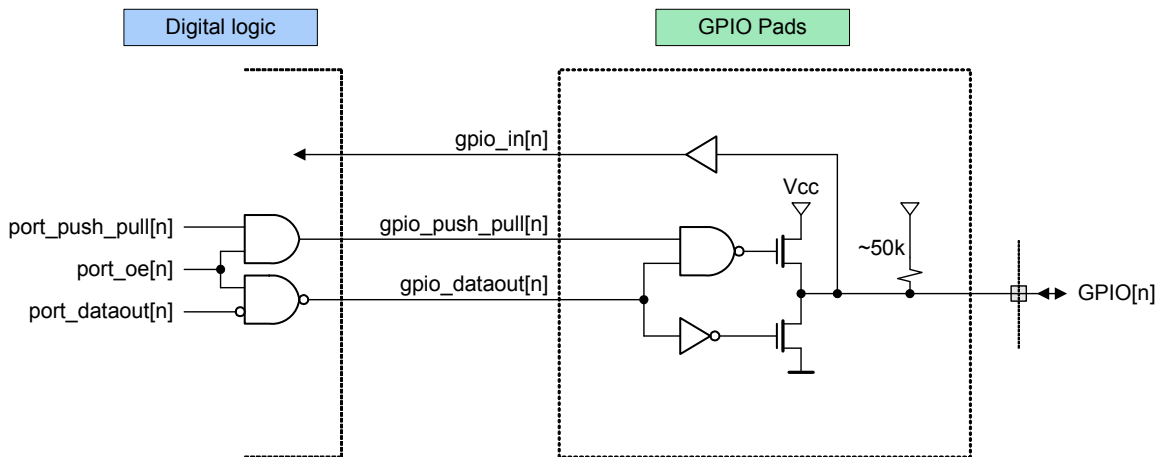

**Figure 30.3. Other GPIO Functional Diagram**



# Si4010-C2

## 30.1. GPIO Pin Special Roles

Not all GPIO ports can be configured as both input and outputs. Given the limited number of GPIO each pin can assume different functionality based on the software configuration of the ports. The functionality of each GPIO is described in Table 30.3.

**Table 30.3. GPIO Special Roles**

GPIO Number	Other Special Roles	C2	FOB	Can Drive Low During Sleep	Pullup Roff Option
0	XO/VPP1 <sup>1</sup>		button		
1			button	Y	Y
2			button	Y	Y
3	clk_ref <sup>2</sup>		button	Y	
4	clk_out out	C2DAT	button		
5		C2CLK	LED <sup>3</sup>		
6 (14 pin only)	clk_out out <sup>4</sup>		button		
7 (14 pin only)			button		
8 (14 pin only)			button		
9 (14 pin only)			button		

**Notes:**

1. Can be set as GPIO input only. Special roles are crystal oscillator (XO) and VPP=6.5V NVM programming voltage supply during NVM programming.
2. Reference clock source for frequency counter.
3. Current mode driver for LED connected directly to VCC supply. GPIO[5] cannot be used for any other purpose in user application.
4. Optional customer clock **clk\_out** output can be set independently on GPIO[4] and GPIO[6], or on both at the same time.

It is important to emphasize the following:

- GPIO[0] can be used only as input for user application. It can also serve as a crystal oscillator input. During device NVM programming the programming VPP=6.5V voltage is applied to this pin.
- GPIO[5] can be used only as a up to 1mA LED current driver. The LED should be connected directly in between the GPIO[5] and VCC. In a development system this pin is used as a C2 interface C2CLK. In the development system the LED has to be isolated from the pin as shown in Figure 35.1 and Figure 35.2. The LED is disabled during debugging.

---

## 30.2. Pullup Roff Option

There is an option to disable the weak pullup pad resistors. This feature is called **Roff** option. The **Roff** option is controlled directly by the GPIO pads and persist when the chip is in the shutdown mode. Control of the **Roff** control bit in the GPIO is described in section 30.4. Pullup Roff and Matrix Mode Option Control.

## 30.3. Matrix Mode Option

The target application of the device is the button intensive application, which samples button pushes at the device inputs and acts accordingly.

Given the pin limited package, the target user application could use at most 5 buttons on a 10-pin package and 9 buttons on 14-pin package. If the chip is in a shutdown mode, any button push (connection to any GPIO to ground) wakes the chip up.

For the applications requiring more push button inputs than the available GPIO inputs, **Matrix** button mode should be implemented on the device. This allows the buttons to be organized in 3x2 matrix for 10 pin package or 3x6 matrix for the 14-pin package, allowing for up to 6 push buttons for 10 pin package and up to 18 buttons on the 14-pin package. It is up to the firmware to scan the matrix sequentially to determine the status of the buttons.

When the buttons are organized in **Matrix** mode any button push must wake the chip up from a shutdown mode. Since the buttons are not connecting GPIO to ground, but connecting an input GPIO to some output GPIO, the output GPIO must be connected to ground during the chip shutdown. That is achieved by setting the Matrix option control bit in the GPIO latch. When that bit is set then the GPIO[3:1] are actively pulled to ground when the chip is in the shutdown mode and digital logic has no power internally.

Note that to use the **Matrix** mode the **Roff** option must not be used. In other words, all the pullup resistors must stay in place for all the GPIO. There should be values `PORT_MATRIX=1` and `PORT_ROFF=0` latched into GPIO options control latch.

When the **Matrix** mode is latched into the GPIO control latch the pullup resistors of the GPIO[3:1] are disconnected and the pull down transistor on those GPIOs is activated.

**Important:** Before invoking a **Matrix** mode the user is responsible for programming all GPIO[3:1] as inputs. This is achieved by writing 1 to `P0[3:1]` and writing 0 to `P0CON[3:1]`. Only after that the **Matrix** option can be invoked.

If the chip went to shutdown with **Matrix** option set, then it will be woken up by any button press of the button matrix. It is a responsibility of the user application which *must turn the **Matrix** mode off* before the software can scan the button matrix for current button status. The button scanning is usually done scanning the matrix driver pins GPIO[3:1] with one-cold pattern, applying sequential binary patterns GPIO[3:1]=110, 101, 011, and 111 using open drain configuration of the GPIO[3:1]. By collecting corresponding responses on the GPIO[4,0] or GPIO[4,0,9:6], input GPIOs to the driving one-cold patterns firmware can determine what buttons are currently pushed.

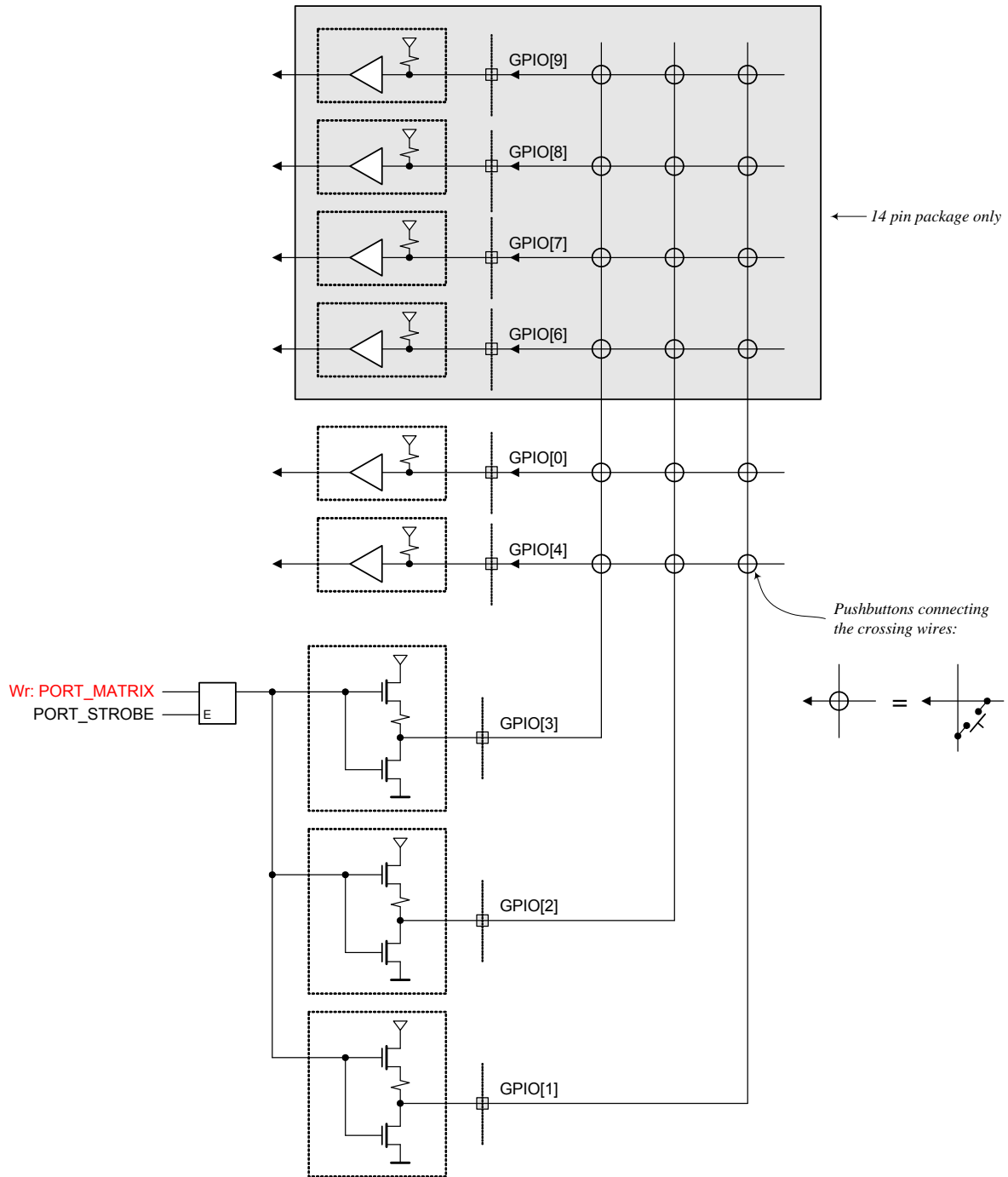

**Figure 30.4. Push Button Organization in Matrix Mode**

---

## 30.4. Pullup Roff and Matrix Mode Option Control

Both **Roff** and **Matrix** mode options are controlled by the GPIO pad itself. The control is implemented as 2 bit latch inside of the GPIO pads. Both options stay in their used defined states during chip shutdown. In other words, if the chip is in shutdown mode, the digital logic does not have power, but the two GPIO latches keep the user set values of those options.

The options are controlled by the PORT\_CTRL SFR register. The user has to strobe the desired values to the GPIO latches by software sequence. The latch enable is a PORT\_STROBE bit in the PORT\_CTRL register.

For example, to disable the both **Matrix** and **Roff** options at the beginning of use application, the user code should look like this in assembly:

```
anl PORT_CTRL, #10011111B    ; Clear PORT_MATRIX and PORT_ROFF
orl  PORT_CTRL, #10000000B    ; Set PORT_STROBE=1
anl  PORT_CTRL, #01111111B    ; Clear PORT_STROBE=0
```

Using Silicon Labs provided masks in the header:

```
anl PORT_CTRL, #NOT(M_PORT_MATRIX OR M_PORT_ROFF)
orl  PORT_CTRL, #M_PORT_STROBE
anl  PORT_CTRL, #NOT(M_PORT_STROBE)
```

The toggle of the PORT\_STROBE from 0 to 1 back to 0 latches the current register values of PORT\_MATRIX and PORT\_ROFF.

To summarize: To change the values of the **Matrix** and **Roff** options, the following software sequence is required:

1. Set the desired values of PORT\_MATRIX and PORT\_ROFF bits in the PORT\_CTRL register.
2. Toggle the PORT\_STROBE bit in the PORT\_CTRL register from 0 to 1 back to 0 while not changing any other bit in the PORT\_CTRL register. The new **Matrix** and **Roff** control values are latched into the GPIO.
3. Note that while reading the PORT\_CTRL the current value of the **Matrix** and **Roff** options is read from the GPIO, **not** the value of the write register for the new **Matrix** and **Roff** setting.

Invoking a **Matrix** mode requires the following sequence:

1. Set the GPIO[3:1] as inputs, which means writing 1 to the port value and making the driver open drain.
2. Latch PORT\_MATRIX=1 and PORT\_ROFF=0 values to the GPIO option control latch.

# Si4010-C2

---

In assembly:

```
orl P0,          #00001110B      ; Turn GPIO[3:1] as inputs
anl P0CON,       #NOT 00001110B
anl PORT_CTRL,  #NOT(M_PORT_MATRIX OR M_PORT_ROFF)
orl PORT_CTRL,  #M_PORT_MATRIX    ; Set Matrix mode and keep resistors
orl PORT_CTRL,  #M_PORT_STROBE    ; Strobe new Matrix/Roff modes to GPIO
anl PORT_CTRL,  #NOT(M_PORT_STROBE)
```

## 30.5. Special GPIO Modes Control

Some of the GPIO serves multiple purposes. Special configuration registers PORT\_CTRL and PORT\_SET are used to configure GPIO for other purpose than regular GPIO. Some GPIO can server multiple special purposes.

Table 30.4 shows all the functionality the GPIO can assume along with control signals and priority of the functionality. The lower the priority number, the higher the functional priority. For example, if the functionality with priority 1 is programmed, then controls selecting functionality of priority 2 and above will be ignored no matter what the control settings are.

Table 30.4. GPIO Special Roles Control and Order

GPIO	Roles	Order	Control	Comment
0	VPP	1		NVM programming voltage VPP = 6.5 V
	XO	2	<b>XO_CTRL.XO_ENA</b>	
	GPIO	3	<b>P0.0</b> fixed as input only	
1	GPIO	1	<b>P0.1</b> <b>P0CON.1</b>	
	Matrix, Roff	Ind*	PORT_CTRL	
2	GPIO	1	<b>P0.2</b> <b>P0CON.2</b>	
	Matrix, Roff	Ind*	PORT_CTRL	
3	Reference clk_ref	1	<b>PORT_SET.PORT_REFEN</b>	Reference interval clock for frequency counter
	GPIO	2	<b>P0.3</b> <b>P0CON.3</b>	
	Matrix	Ind*	PORT_CTRL	
4	C2DAT	1	Automatically “stolen” from application during C2 transaction.	
	Output clk_out	2	<b>PORT_SET.PORT_CLKEN</b> <b>PORT_SET.PORT_CLKOUT[0]</b>	Cannot be used in the development system, since C2 transaction disrupts the output.
	GPIO	3	<b>P0.4</b> <b>P0CON.4</b>	
5	C2CLK	1	Acts as if a C2 debug clock input of the LED driver is not turned on.	
	LED driver	2	<b>P0.5</b> <b>PORT_CTRL.PORT_LED[1:0]</b>	Port forced as output. To read the actual LED driver status (on/off) the user should read <b>RBIT_DATA.GPI-O_LED_DRIVE</b>
6	Output clk_out	1	<b>PORT_SET.PORT_CLKEN</b> <b>PORT_SET.PORT_CLKOUT[1]</b>	14 pin only
	GPIO	2	<b>P0.6</b> <b>P0CON.6</b>	
7	GPIO	1	<b>P0.7</b> <b>P0CON.7</b>	14 pin only
8	GPIO	1	<b>P1.0</b> <b>P1CON.0</b>	14 pin only
9	GPIO	1	<b>P1.1</b> <b>P1CON.1</b>	14 pin only

\*Note: Ind stands for “Independent” setting. The **Matrix** and **Roff** modes are controlled in analog pad circuitry.

# Si4010-C2

## 30.6. LED Driver on GPIO[5]

For application mode the GPIO[5] is shared with LED current driver. The LED current driver provides three levels of LED current, 1mA maximum. The current levels are described in SFR Definition 30.6. User can set the current intensity and then control the LED on and off by P0.5, port P0 bit 5, as a regular output. There is no need to modify the P0CON.5 bit, since the GPIO[5] output driver is set to be open drain. When the LED driver is on by setting the P0.5=1 then the pulldown output transistor is disabled. The GPIO[5] is used as a regular open drain output during the C2 debugging sessions only.

During the C2 debug sessions the IDE will forcibly disable the LED driver so the LED drive will not interfere with the debugging session. There will be an option on IDE to disable the “LED disable”, but it will have to be used with caution.

When the user hits **Disconnect** button on the IDE then the IDE clears all breakpoint, removes the LED disable, and runs the application from the point where it was halted. Then the application will control the LED. The user then can hit the **Connect** button on the IDE to connect to the chip again. For the IDE to be able to connect to the chip the LED must not be driven (not lit).

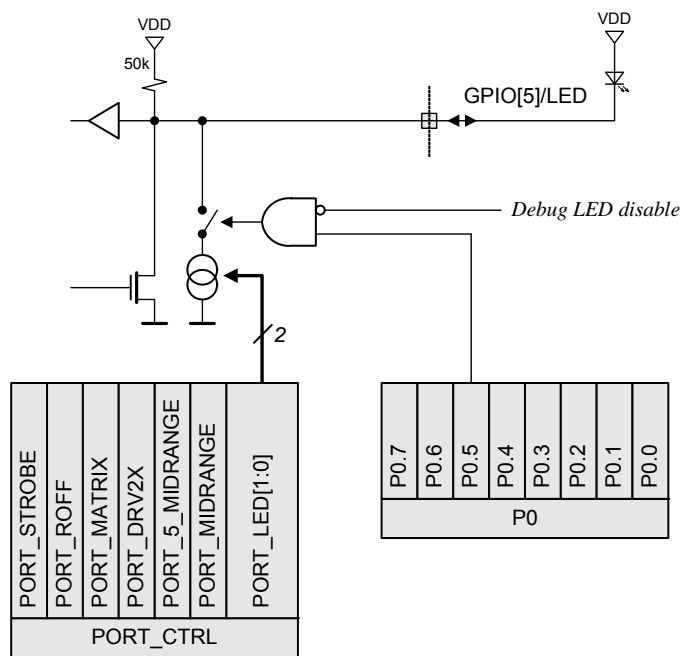

Figure 30.5. GPIO[5] LED Driver Block Diagram

---

**SFR Definition 30.1. P0**

---

Bit	7	6	5	4	3	2	1	0
Name	P0[7:0]							
Type	R/W	R/W	R/W	R/W	R/W	R/W	R/W	R/W
Reset	1	1	0	1	1	1	1	1

SFR Address = 0x80

Bit	Name	Function
7:0	P0[7:0]	<p><b>Port 0 Register, GPIO[7:0], Bit Addressable.</b></p> <p>Write appears at the GPIO[7:0] outputs, read reads directly the GPIO input values.</p> <p>Write:</p> <p>0 .. output low value</p> <p>1 .. output open-drain or high drive value in push-pull mode</p> <p>Read:</p> <p>0 .. GPIO pin is at logic low value</p> <p>1 .. GPIO pin is at logic high value</p> <p>Special pins:</p> <p>The GPIO[0] is input only. Write to GPIO[0] has no effect. The GPIO[5] is output LED driver only and requires setting of the proper LED drive current. Then GPIO[5] just turns the LED current on (1) or off (0). Reading from GPIO[5] returns the user intended driver of LED (1 .. driving, 0 .. off). The read value will be read as 0 if, for example, the user writes GPIO[5] as 1, but the LED current value PORT_CTRL.PORT_LED will be 0.</p> <p>The read GPIO[5] value does not represent the actual driving status of the LED drive, since the debug logic and C2 can disable the LED. The actual LED driving status can be read as RBIT_DATA.GPIO_LED_DRIVE bit.</p>



# Si4010-C2

## SFR Definition 30.2. P0CON

Bit	7	6	5	4	3	2	1	0
Name	P0CON[7:0]							
Type	R/W	R/W	R/W	R/W	R/W	R/W	R/W	R/W
Reset	0	0	0	0	0	0	0	0

SFR Address = 0xA4

Bit	Name	Function
7:0	P0CON[7:0]	<p><b>Port 0 Configuration Register, for GPIO[7:0].</b></p> <p>This bit controls configuration of each corresponding output bit in P0.</p> <p>0 .. open-drain 1 .. push-pull</p> <p>If the pin to be input, it must be configured as open-drain and 1 has to be written as output value to it.</p>

## SFR Definition 30.3. P1

Bit	7	6	5	4	3	2	1	0
Name	P1[7:0]							
Type	R/W	R/W	R/W	R/W	R/W	R/W	R/W	R/W
Reset	0	0	0	0	0	0	1	1

SFR Address = 0x90

Bit	Name	Function
7:0	P1[7:0]	<p><b>Port 1 Register GPIO[15:8], Bit Addressable.</b></p> <p>Write appears at the GPIO[15:8] outputs, read reads directly the GPIO input values. Same as for P0. Only GPIO[9:8] are used, write to the rest of the register has no effect, read returns 0 at those bits.</p>

**SFR Definition 30.4. P1CON**

Bit	7	6	5	4	3	2	1	0
Name	P1CON[7:0]							
Type	R/W	R/W	R/W	R/W	R/W	R/W	R/W	R/W
Reset	0	0	0	0	0	0	0	0

SFR Address = 0xA5

Bit	Name	Function
7:0	P1CON[7:0]	<p><b>Port 1 Register GPIO[15:8], Bit Addressable.</b></p> <p>This bit controls configuration of each corresponding output bit in P1.            0 .. open-drain, pull up resistor connected (see PORT_ROFF)            1 .. push-pull, pull up resistor disabled</p> <p>If the pin to be input, it must be configured as open-drain and 1 has to be written as output value to it. Only bits [1:0] corresponding to GPIO[9:8] are used, write to the rest of the register has no effect, read returns 0 for those bits.</p>

**SFR Definition 30.5. P2**

Bit	7	6	5	4	3	2	1	0
Name	P2[7:0]							
Type	R/W	R/W	R/W	R/W	R/W	R/W	R/W	R/W
Reset	0	0	0	0	0	0	0	0

SFR Address = 0xA0

Bit	Name	Function
7:0	P2[7:0]	<p><b>Port 2 Register, Bit Addressable.</b></p> <p>It is not a port, but a regular register. This register is used as a page MSB address byte for XDATA addressing in mode, using the PDATA memory accesses. The sole purpose for it is to support the PDATA model.</p>

# Si4010-C2

## SFR Definition 30.6. PORT\_CTRL

Bit	7	6	5	4	3	2	1	0
Name	PORT_STROBE	PORT_ROFF	PORT_MATRIX	PORT_DRV2X	PORT_5_MID-RANGE	PORT_MID-RANGE	PORT_LED[1:0]	
Type	R/W	R/W	R/W	R/W	R/W	R/W	R/W	R/W
Reset	0	—	—	0	1	1	0	0

SFR Address = 0xB5

Bit	Name	Function
7	PORT_STROBE	<b>Port Strobe.</b> Strobe the port_matrix and port_roff bits values from this register to the GPIO pads. The operation requires additional 2 CPU clock to finish after writing 0->1->0 to this bit. When 1 is written to this bit the GPIO latches open and the values of port_matrix and port_off are propagated to GPIO pads. Software must clear this bit to capture those two bits in the GPIO pads internal HV permanent latches.
6	PORT_ROFF	<b>Port Roff Mode.</b> Roff mode, read from this bit returns the actual Roff mode value as reported from GPIO pad. When a 1 is latched into the GPIO pad internal Roff mode HV latch then the GPIO Roff mode gets invoked. The GPIO[1:2] will have their pull-up resistors turned off.
5	PORT_MATRIX	<b>Port Matrix Mode.</b> Matrix mode, read from this bit returns the actual value matrix mode value as reported from GPIO pad. When a 1 is latched into the GPIO pad internal matrix mode HV latch then the GPIO matrix mode gets invoked. The GPIO[1:3] are driven low with resistor pull-ups disabled. This is intended for matrix button mode to wake up from sleep mode.
4	PORT_DRV2X	<b>Increase Drive Strength by 2x on All Outputs.</b>
3	PORT_5_MIDRANGE	<b>Input GPIO[5] pin trip point set to 45% VDD.</b>
2	PORT_MIDRANGE	<b>Input GPIO Pin Trip Point Set to 45% VDD (except GPIO[5])</b>
1:0	PORT_LED [1:0]	<b>LED Current Drive Strength.</b> It must be set to non-zero value for LED to have any current. This is just a current source setting. The actual turning of the LED on and off is controlled by the GPIO[5] output bit in P0. 00: LED off 01: LED current = 0.62*600uA 10: LED current = 1.00*600uA 11: LED current = 1.62*600uA

**SFR Definition 30.7. PORT\_SET**

Bit	7	6	5	4	3	2	1	0
Name	EDGE_INT1	EDGE_INT0	PORT_CLKOUT[1:0]		PORT_CLKEN	PORT_REFEN	Reserved	Reserved
Type	R/W	R/W	R/W	R/W	R/W	R/W	R/W	R/W
Reset	0	0	0	0	0	0	0	0

SFR Address = 0xB6

Bit	Name	Function
7	EDGE_INT1	<b>Edge Control for INT1.</b> This bit controls whether single edge or both edges invoke the interrupt. 0: Single edge, polarity specified by NEG_INT1 in PORT_INTCFG. 1: Both edges, which means any edge, invoke INT1 interrupt.
6	EDGE_INT0	<b>Edge Control for INT0.</b> This bit controls whether single edge or both edges invoke the interrupt. 0: Single edge, polarity specified by NEG_INT0 in PORT_INTCFG. 1: Both edges, which means any edge, invoke INT0 interrupt.
5:4	PORT_CLKOUT [1:0]	<b>Select which GPIO Pin is used as Clock Output Pin.</b> PORT_CLKOUT[0]: 1 .. clk output at GPIO[4], 0 .. normal/other GPIO[4] operation PORT_CLKOUT[1]: 1 .. clk output at GPIO[6], 0 .. normal/other GPIO[6] operation Both outputs can be used simultaneously. The actual clock waveform can be enabled/disabled by port_clken bit, but the GPIO configuration is purely controlled by PORT_CLKOUT.
3	PORT_CLKEN	<b>Enable Output Clock, Which is Possibly Coming out on GPIO[4] and/or GPIO[6].</b> This bit is just a clock enable/disable, it does not configure the GPIO for clock outputs. The port configuration must be done by port_clkout below. The generated clock division is controlled by CLKOUT_SET register. If the clock is disabled by PORT_CLKEN=0 the current period in progress will be finished and the output clock will stop as logic 0.
2	PORT_REFEN	<b>Enable CLK_REF Reference Clock to come from GPIO[3].</b> The GPIO[3] pad is forced to be an input. There is not need to change p0 or p0con register values, since port_refen has higher priority.
1:0	Reserved	These bits must be left at 0.

## 31. Clock Output Generation

The device includes an option to be used as a clock generator for other chips connected to the device. The generated clock frequency, **clk\_out**, is derived from the internal 24MHz oscillator. System clock division set in SYSGEN register has no effect on the **clk\_out** frequency.

The **clk\_out** is an output of a divider with programmable division from 1 to 31 in an increment of 1. Therefore, the output frequency of the output clock can range from 24MHz to  $24\text{MHz}/31 = 774\text{kHz}$ .

The divider has an option to keep the **clk\_out** duty cycle to 1:1 even for odd division ratios. There is an option of at which logic level the **clk\_out** stops when the clock generator is disabled.

The clock divider/generator always finishes the period it started before it accepts a new division factor **CLKOUT\_DIV**. It is recommended to fix all the settings before enabling the output clock generator. The master enable is **PORT\_CLKEN** bit in the **PORT\_SET** register.

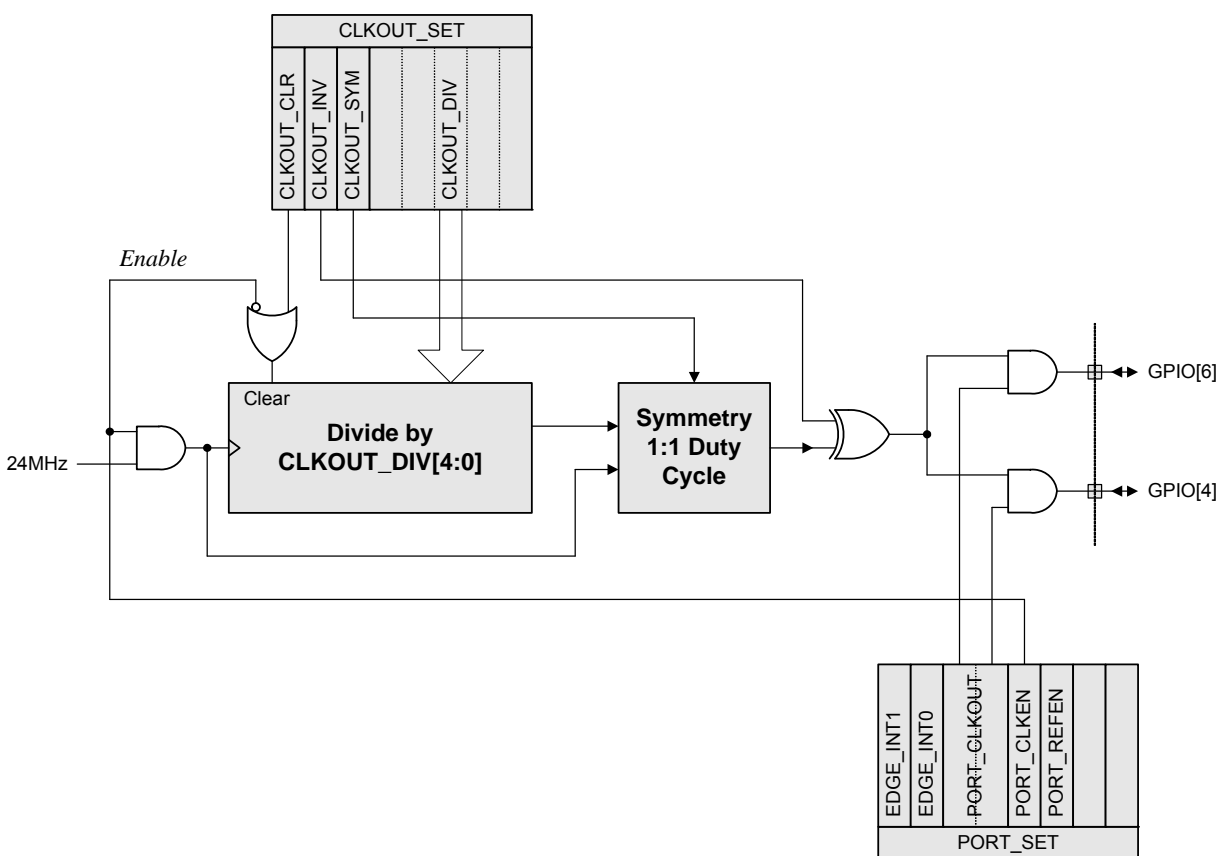

Figure 31.1. Output Clock Generator Block Diagram

### 31.1. Register Description

#### SFR Definition 31.1. CLKOUT\_SET

Bit	7	6	5	4	3	2	1	0
Name	CLKOUT_ CLR	CLKOUT_ INV	CLKOUT_ SYM	CLKOUT_DIV[4:0]				
Type	R/W	R/W	R/W	R/W	R/W	R/W	R/W	R/W
Reset	0	0	0	0	0	0	0	0

SFR Address = 0x8F

Bit	Name	Function
7	CLKOUT_ CLR	<p><b>CLKOUT Clear.</b> Write 1 to this bit clears the generated clock divider. The generated clock output is forced to 0. Reading this bit has CLKOUT_IDLE meaning. If read as 1 then it indicates that the clock divider generator is idle. It can be used to wait for the clock to get idle after the user clock output was disabled by PORT_SET.PORT_CLKEN=0. If this bit is read as 0 the clock division generator by factor 2 and above is running and the current user clock period is still in progress. The user could use this bit to synchronously switch the CLKOUT_DIV division factor, but it is not necessary. The synchronous clock period switching is built in the hardware. See the CLKOUT_DIV field description of this register. To switch the clocks immediately without waiting for the current period to end, write 1 to this bit. The write 1 to this bit can be combined with setting the new CLKOUT_DIV value in this register at the same time.</p>
6	CLKOUT_ INV	<p><b>CLKOUT Inversion.</b> Invert the generated clock. The inverter is at the very end of the clock generation chain. Normally, if this bit is 0, if the generated clock is disabled the output is at 0. With this bit set to 1 the output is inverted, therefore the generated clock stops at 1. This bit must be set before customer clock is enabled to the port output by setting PORT_SET.PORT_CLKEN=1. If changed later the clock inversion takes effect immediately with possibility of short clock pulse being generated at the clock output.</p>

# Si4010-C2

Bit	Name	Function
5	CLKOUT_SYM	<p><b>CLKOUT Symmetry.</b>            If this bit set to 1 then the output clock duty cycle is very close to 1:1 irrespective of the division factor. However, the generated clock waveform is a combination of outputs of two flops and therefore might jitter more. If this bit is 0 then for odd division factor there is a single 24 MHz period difference in between halves of the generation output clock.            This bit must be set before customer clock is enabled to the port output by setting PORT_SET.PORT_CLKEN=1.</p>
4:0	CLKOUT_DIV[4:0]	<p><b>CLKOUT Division Factor.</b>            Division factor of the 24 MHz oscillator clock for generation of the output customer clock. The enable of the clock is controlled by the PORT_CLKEN and PORT_CLKOUT bits in PORT_SET register. The division factors 0 and 1 pass the 24 MHz internal cheap oscillator output as output clocks. Value bigger than 1 is the actual division factor of the 24 MHz.            If CLKOUT_SYM=0 (recommended), the generated clock is an output of a flop. For odd division ratios the first part of the period in logic 0 is one 24 MHz clock cycle shorter than the second high half part of the period of generated clock, assuming CLKOUT_INV=0.            If the clock is disabled by PORT_CLKEN=0 the current period in progress will be finished. To monitor when the output gets idle monitor the CLKOUT_CLR bit of this register.            The CLKOUT_DIV bit can be changed any time. The new setting will take effect only after the current period finishes. For the new setting to take effect immediately see CLKOUT_CLR.</p>

## 32. Control and System Setting Registers

The following are general system setting control registers as well as general purpose scratch pad registers. GPR\_CTRL and GPR\_DATA can be used as a general purpose 2 byte SFR register. They do not control any hardware on the device.

### SFR Definition 32.1. GPR\_CTRL

Bit	7	6	5	4	3	2	1	0
Name	GPR_CTRL[7:0]							
Type	R/W	R/W	R/W	R/W	R/W	R/W	R/W	R/W
Reset	0	0	0	0	0	0	0	0

SFR Address = 0xB1

Bit	Name	Function
7:0	GPR_CTRL[7:0]	General Purpose Register.

### SFR Definition 32.2. GPR\_DATA

Bit	7	6	5	4	3	2	1	0
Name	GPR_DATA[7:0]							
Type	R/W	R/W	R/W	R/W	R/W	R/W	R/W	R/W
Reset	0	0	0	0	0	0	0	0

SFR Address = 0xB2

Bit	Name	Function
7:0	GPR_DATA[7:0]	General Purpose Register.



# Si4010-C2

## SFR Definition 32.3. RBIT\_DATA

Bit	7	6	5	4	3	2	1	0
Name	Reserved	Reserved	GPIO_LED_DRIVE	XO_CKGOOD	ODS_EMPTY	ODS_NO-DATA	Reserved	Reserved
Type	R	R	R	R	R	R	R	R
Reset	0	0	0	0	1	1		

SFR Address = 0x99

Bit	Name	Function
7:6	Reserved	Read as 0x0. Write has no effect.
5	GPIO_LED_DRIVE	<b>GPIO LED Drive.</b> Actual status of the LED drive. If this bit is at 1, then the LED driver is actually on. The LED driver is controlled by P0.5 bit and the intensity value in PORT_CTRL register. If the P0.5 bit is read, then it returns user LED drive request, which does not reflect the actual LED driver status.
4	XO_CKGOOD	<b>Crystal Oscillator Clock Good.</b> Crystal oscillator XO output is stable.
3	ODS_EMPTY	<b>ODS Empty.</b> Supplementary flag indicating that the ODS Tx holding register is empty. It can be used as an indication for software to write a new data byte to ODS_DATA register to transmit. This applies to the Tx holding register only. See ODS_NODATA for the flag related to the actual Tx shift register.
2	ODS_NODATA	<b>ODS No Data.</b> Supplementary flag that the output digital serializer (ODS) Tx shift register ran out of data and there is nothing else to transmit.
1:0	Reserved	Reserved. Can read either 0 or 1.

### 33. Real Time Clock Timer

The Si4010 device contains a real time clock (RTC) timer. This dedicated timer provides accurate interrupt request pulses in precise time intervals. The device does not contain any hardware nor any battery backed up real time clock. The purpose of RTC timer is to provide accurate time intervals for user application at run time, not an absolute real calendar time.

The RTC timer clock source is the internal calibrated system clock generator. The RTC constant tick generator runs from the selected divided internal system clock, which is a power of two division of the 24 MHz internal oscillator. The frequency ranges from 24 MHz down to 24 MHz/128. The RTC tick generated is a constant frequency of 24 MHz/128 with tick period 5.33  $\mu$ s and is independent of the system clock division setting SYSGEN\_DIV in the SYSGEN SFR register.

The user can select what exact time intervals the RTC timer will set its interrupt flag. The time interval is programmable to be one of the following: 100  $\mu$ s, 200  $\mu$ s, 400  $\mu$ s, 800  $\mu$ s, 1 ms, 2 ms, and 5 ms. This time is independent of the selected system clock divider in the SYSGEN SFR register.

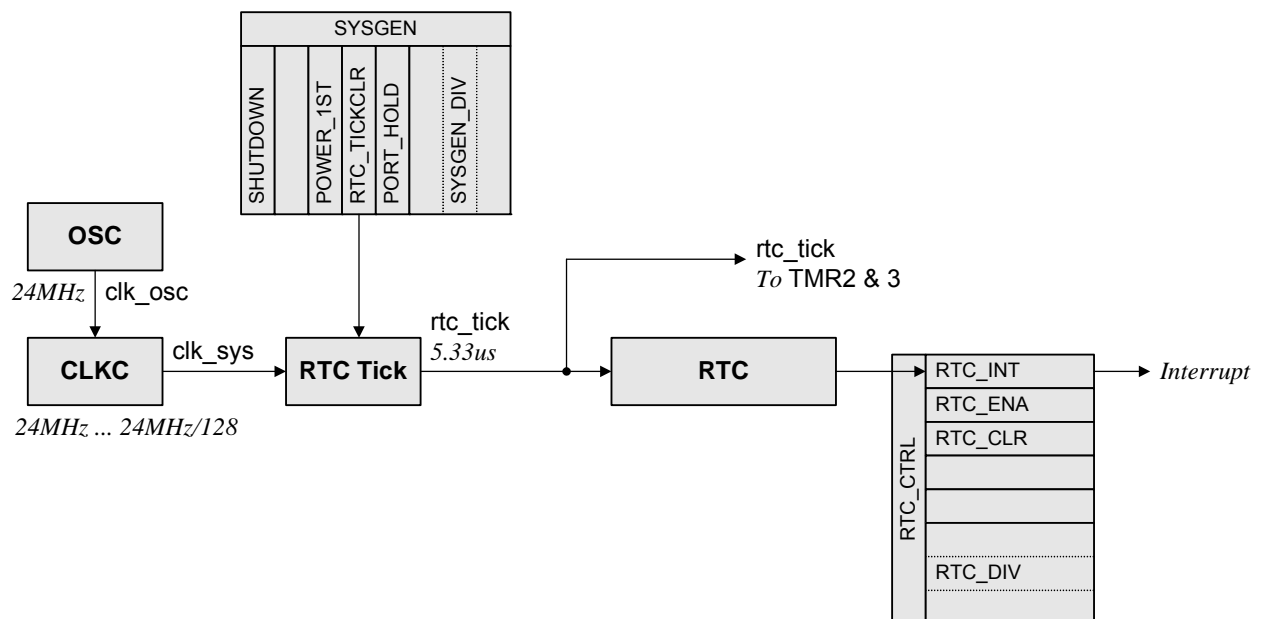

Figure 33.1. RTC Timer Block Diagram

## 33.1. RTC Interrupt Flag Time Uniformity

Since 100  $\mu$ s and 200  $\mu$ s pulse duration is not exactly an integer multiple of the 24 MHz/128 frequency, the fractional division was used. The 100  $\mu$ s and 200  $\mu$ s pulse durations are uniform *on average*, when observed over a sufficiently long timer period. Instantaneous time difference in between subsequent 100  $\mu$ s and 200  $\mu$ s pulses is not 100  $\mu$ s or 200  $\mu$ s, respectively, but fluctuates around those two values.

- 100  $\mu$ s pulse train .. the 100  $\mu$ s pulse train consists of **rtc\_tick** time duration of 19, 19, 19, 18 ticks. That means that 3 subsequent 100  $\mu$ s pulses has time difference of 19 x **rtc\_tick** periods, which is 19 x 5.33  $\mu$ s = 101.33  $\mu$ s. That is followed by a single duration or 18 x **rtc\_tick** period duration, which is 18 x 5.33  $\mu$ s = 96  $\mu$ s. On average, the 100  $\mu$ s pulse time period is (3 x 19 + 18)/4 x **rtc\_tick** period, which is 18.75 x 5.33  $\mu$ s = 100  $\mu$ s exactly.
- 200  $\mu$ s pulse train .. for 200  $\mu$ s the pulse train consists of **rtc\_tick** time duration of 38, 37 ticks. That means that the pulse train is an alternation train of 38 x 5.33  $\mu$ s = 202.66  $\mu$ s and 37 x 5.33  $\mu$ s = 197.33  $\mu$ s, when on average the duration is (38 + 37)/2 x 5.33  $\mu$ s = 200  $\mu$ s exactly.

The pulse trains for 400  $\mu$ s pulses and longer have a uniform, exact, time periods.

## 33.2. Register Description

The RTC timer is controlled by the RTC\_CTRL SFR register. If there is a need for precise beginning of the RTC timer period, the internal tick generator can be cleared by writing a bit RTC\_TICKCLR in the SYSGEN register.

The **rtc\_tick** generator runs freely whenever the RTC timer is enabled by RTC\_ENA=1. If the user needs to clear the RTC timer to synchronize it with some event, writing 1 to RTC\_CLR will clear the timer, which keeps running. The RTC **rtc\_tick** generator is not cleared by that event. Therefore, there will be up to 5.33  $\mu$ s time uncertainty in the calculated time period. Clearing of the RTC **rtc\_tick** generator is achieved by writing 1 into the RTC\_TICKCLR bit in SYSGEN register.

To achieve exact synchronization it is recommended to write 1 into the RTC\_TICKCLR, then 1 to RTC\_CLR, followed by another 1 into the RTC\_TICKCLR. In assembly using the M\_<field> masks 8-bit mask notation from the supplied assembly include file:

```
orl SYSGEN,    #M_RTC_TICKCLR
orl RTC_CTRL,  #M_RTC_CLR
orl SYSGEN,    #M_RTC_TICKCLR
```

The reason for splitting the clear is that the RTC tick output, **rtc\_tick** can also be selected as a time source for TMR2 and TMR3, so there is a need to have separate control over the **rtc\_tick** generator clearing.

To get the RTC tick generator running the RTC\_ENA=1 must be set. Therefore, even if the RTC interrupt is not used, the RTC timer must be enabled if the user wants to use the **rtc\_tick** as a clock source for TMR2 or TMR3.

---

**SFR Definition 33.1. RTC\_CTRL**

---

Bit	7	6	5	4	3	2	1	0
Name	RTC_INT	RTC_ENA	RTC_CLR	Reserved	Reserved	RTC_DIV[2:0]		
Type	R/W	R/W	W	R	R	R/W		
Reset	0	0	0	0	0	0	0	0

SFR Address = 0x9C

Bit	Name	Function
7	RTC_INT	<b>Real Time Clock Interrupt Flag.</b> Set after the time interval set by RTC_DIV field elapses. Software must clear the flag. Hardware will not clear the flag
6	RTC_ENA	<b>Real Time Clock Enable.</b> If set to 1 then the RTC_TICK and bottom part of the pulse generator starts running where it left off. If RTC_DIV >=3 then top half also starts. 0: RTC disabled 1: RTC enabled.
5	RTC_CLR	<b>Real Time Clock Clear.</b> Writing 1 will clear the pulse generator but will leave the RTC_TICK generator intact. See the RTC_TICKCLR in the SYSGEN register for clearing the RTC_TICK counter. 0: Normal operation 1: RTC cleared
4:3	Reserved	Read as 0x00. Write has no effect.
2:0	RTC_DIV [2:0]	<b>Real Time Clock Divider.</b> Select the divider of the RTC_TICK to determine the interval for the RTC interrupt generation. 000: No interrupt generation 001: 100 $\mu$ s .. it is a 19/19/19/18 divider 010: 200 $\mu$ s .. it is a 38/37 divider 011: 400 $\mu$ s 100: 800 $\mu$ s 101: 1 ms 110: 2 ms 111: 5 ms

## 34. Timers 2 and 3

The Si4010 device includes two identical timers, Timer 2 (TMR2) and Timer 3 (TMR3). Since the timers are identical, the description will refer to Timer 2 (TMR2). The reader can replace the TMR2 with TMR3 in the text to get the description of Timer 3 (TMR3). The description refers to a “Timer” as an alias for either TMR2 or TMR3.

Timer 2 is a 16-bit timer formed by two 8-bit SFRs: TMR2L (low byte) and TMR2H (high byte). Timer may operate in one of the two width modes:

- **Wide** mode .. timer operates as a single 16 bit wide timer controlled by the control bits related to the low half of the timer, like TMR2L\_MODE, etc. The timer sets the TMR2INTH bit as an interrupt flag.
- **Split** mode .. timer operates as two independent 8 bit wide times, with related control bits related to high (H) and low (L) half of the overall 16 bit timer.

In each of the width modes each timer or each half of the timer can operate in two different functional modes:

- **Timer** mode .. the timer runs as a counter counting up, when it overflows it sets corresponding interrupt flag, reloads initial value, and keeps going, counting up.
- **Capture** mode .. the timer counter is free running counting up. When it overflows it keeps counting up from 0. When an external capture event happens then the current value of the timer is captured in the capture register, the counter keeps counting and will not stop. The interrupt flag is set by the capture event.

Each timer or timer half can be independently clocked from one of 4 clock sources. Clock source can be independently set for each half of the timer in **split** mode. The clock sources available for each timer half are:

1. Current system clock **clk\_sys**. This is 24MHz, possibly divided by N-th power of 2 with N=0, ..., 7. See SYSGEN SFR register for system clock setting details.
2. Current system clock **clk\_sys** divided by 12 .. **clk\_sys/12**
3. RTC timer tick **rtc\_tick** with 5.33us period (24MHz/128)
4. RTC timer 100us pulse. See the RTC section for an important note related to the uniformity of the 100us pulse train.

All clock sources are synchronous with the system clock.

The capture event is INT0 for TMR2 and INT1 for TMR3. They are edge events coming from external GPIO and are the same as for the external interrupt generation, INT0 and INT1. To use these events as capture events they have to be programmed exactly the same way as if they were intended to be used for interrupt generation. They could generate INT0 and INT1 interrupts at the same time when they are being used as capture events for TMR2 and TMR3, respectively.

If the timer operates in **split** mode both halves are completely independent. Therefore, all 4 combinations of functionality in **split** mode, timer/timer, timer/capture, capture/timer, and capture/capture are possible. Each half has separate clock selection. The only common thing is the capture signal, which is the same for both halves in **split** mode. The only difference in between of two halves in capture/capture mode can be the counter clock, set independently for each half.

# Si4010-C2

## 34.1. Interrupt Flag Generation

Timer 2 has a single interrupt signal going to interrupt controller. Internally, there are 2 interrupt flags, TMR2INTH for high half of the timer and TMR2INTL for low half of the timer, which are combined to generate the final interrupt signal. The low half has a local interrupt flag enable TMR2INTL\_EN control bit.

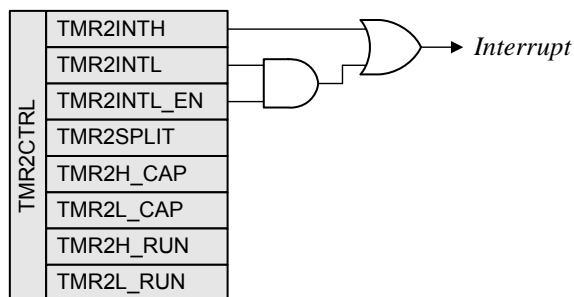

**Figure 34.1. Timer Interrupt Generation**

Setting of the interrupt flags depends on the width and functional modes of each timer or its half.

### ■ Wide mode

#### 1 Timer mode

TMR2INTH set if TMR2H overflows

TMR2INTL set if TMR2L overflows

#### 1 Capture mode

TMR2INTH set if capture event happens and TMR2H, TMR2L 16-bit value gets captured

TMR2INTL set if TMR2H overflows.

**Note:** This is an exception when low interrupt flag gets set based on the high half of the timer. This is a supplemental information for the interrupt handler about the capture, indicating that the 16-bit counter overflow in between captures.

### ■ Split mode

#### 1 Timer mode

TMR2INTH set if TMR2H overflows

TMR2INTL set if TMR2L overflows

#### 1 Capture mode

TMR2INTH set by capture event when TMR2H gets captured

TMR2INTL set by capture event when TMR2L gets captured

Each of the modes is described in a separate section. There is a clock selection register TMR\_CLKSEL common for both Timer 2 and Timer 3.

### 34.2. 16-bit Timer with Auto Reload (Wide Mode)

When TMR2SPLIT=0 and TMR2L\_CAP=0, the timer operates as a 16-bit timer with auto reload.

As the 16-bit timer register increments and overflows from 0xFFFF to 0x0000, the 16-bit value in the time reload registers (TMR2RH and TMR2RL) is loaded into the timer register as shown in Figure 34.2, and the timer High Byte Overflow Flag TMR2INTH (TMR2CTRL.7) is set. If timer interrupts are enabled (see IE and EIE1 registers), an interrupt will be generated on each timer overflow. Additionally, if timer interrupts are enabled and the TMR2INTL\_EN bit is set (TMR2CTRL.5), an interrupt will be generated each time the lower 8 bits (TMR2L) overflow from 0xFF to 0x00.

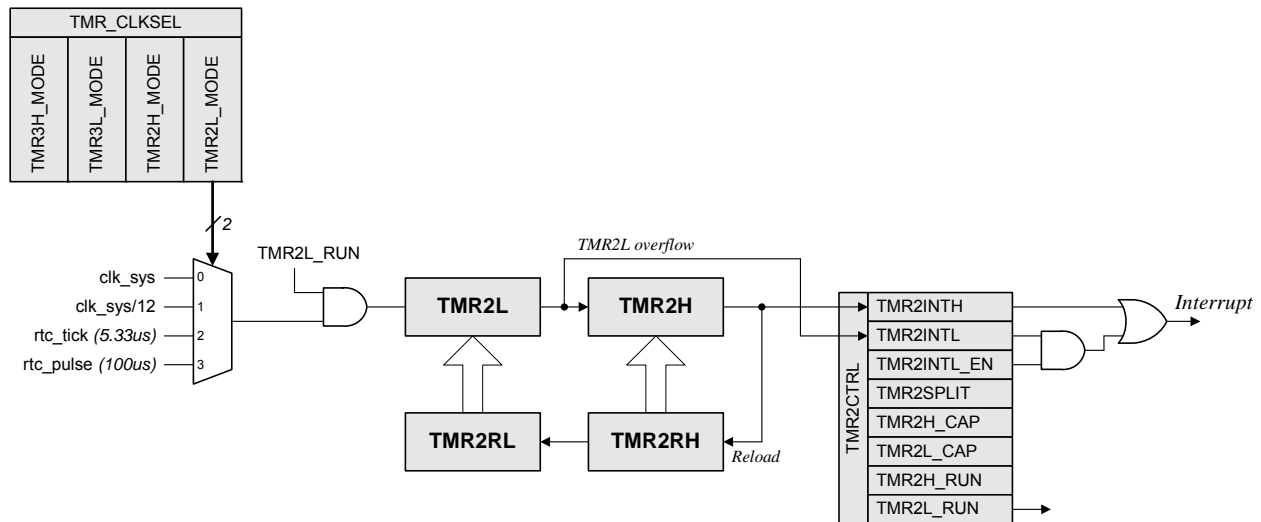

Figure 34.2. Timer 16-bit Mode Block Diagram (Wide Mode)

### 34.3. 16-bit Capture Mode (Wide Mode)

When TMR2SPLIT=0 and TMR2L\_CAP=1, the timer operates in a 16-bit capture mode. The capture event is INT0 for Timer 2 and INT1 for Timer 3. It is the same edge event as programmed to generate external interrupt INT0 or INT1, respectively. The capture event can be positive edge, negative edge, or both edges of the GPIO associated with the INT0 and INT1. Capture mode can be used for measurement of time intervals on external signals.

Timer counts up and overflows from 0xFFFF to 0x0000. Each time a capture event is received, the contents of the timer registers (TMR2H:TMR2L) are latched into the timer reload registers (TMR2RH:TMR2RL). A timer high half interrupt TMR2INTH is generated by capture event. Additionally, the low byte interrupt flag TMR2INTL is set whenever the timer overflows from 0xFFFF to 0x0000. This additional information may be used by an application.

Note that the capture event can also generate its own external interrupt on top of the timer interrupt, if enabled by the application. Also note that if the capture timer is stopped (TMR2L\_RUN=0) the capture event still captures the current counter registers (TMR2H:TMR2L) into the timer reload registers (TMR2H:TMR2RL) and sets the flag TMR2INTH.

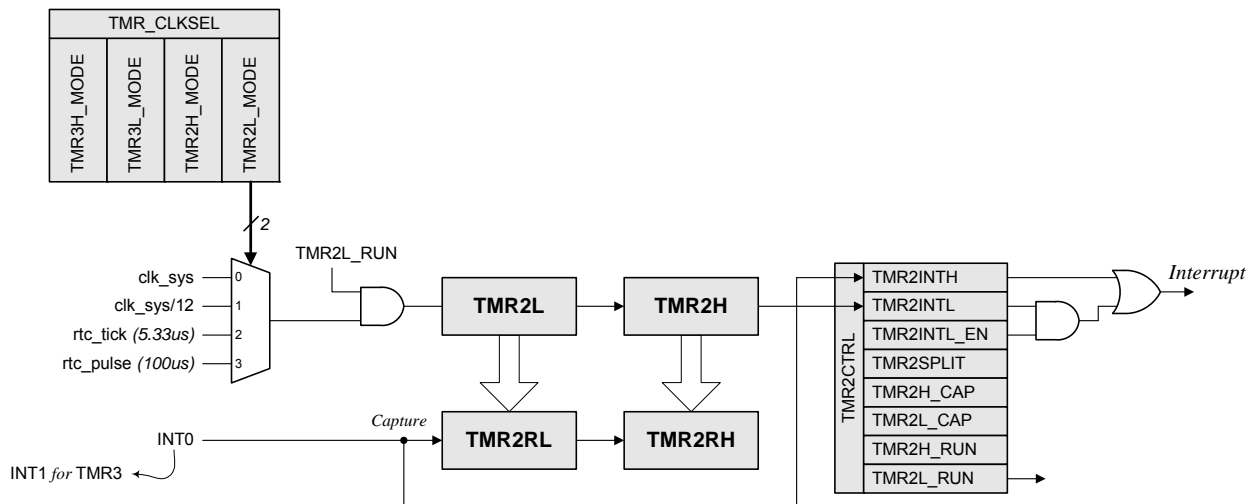

**Figure 34.3. Capture 16-bit Mode Block Diagram (Wide Mode)**

## 34.4. 8-Bit Timer/Timer Mode (Split Mode)

When TMR2SPLIT=1, the timer operates as two independent 8-bit timers. Each of the 8-bit timers can independently operate in either 8-bit timer or 8-bit capture modes. The only common signals for both 8-bit timers are capture event input signal and the interrupt output signal. Therefore, four possible configurations are possible in split mode. All of them are described in the subsequent sections.

If TMR2L\_CAP=0 and TMR2H\_CAP=0, both halves operate as two independent 8-bit timers with independently set clocks.

As the 8-bit timer register increments and overflows from 0xFF to 0x00, the 8-bit value in the time reload registers (TMR2RH or TMR2RL) is loaded into the corresponding timer register (TMR2H or TMR2L), and the corresponding byte overflow flag TMR2INTH or TMR2INTL are set, respectively. If timer interrupts are enabled (see IE and EIE1 registers), an interrupt will be generated on each timer overflow.



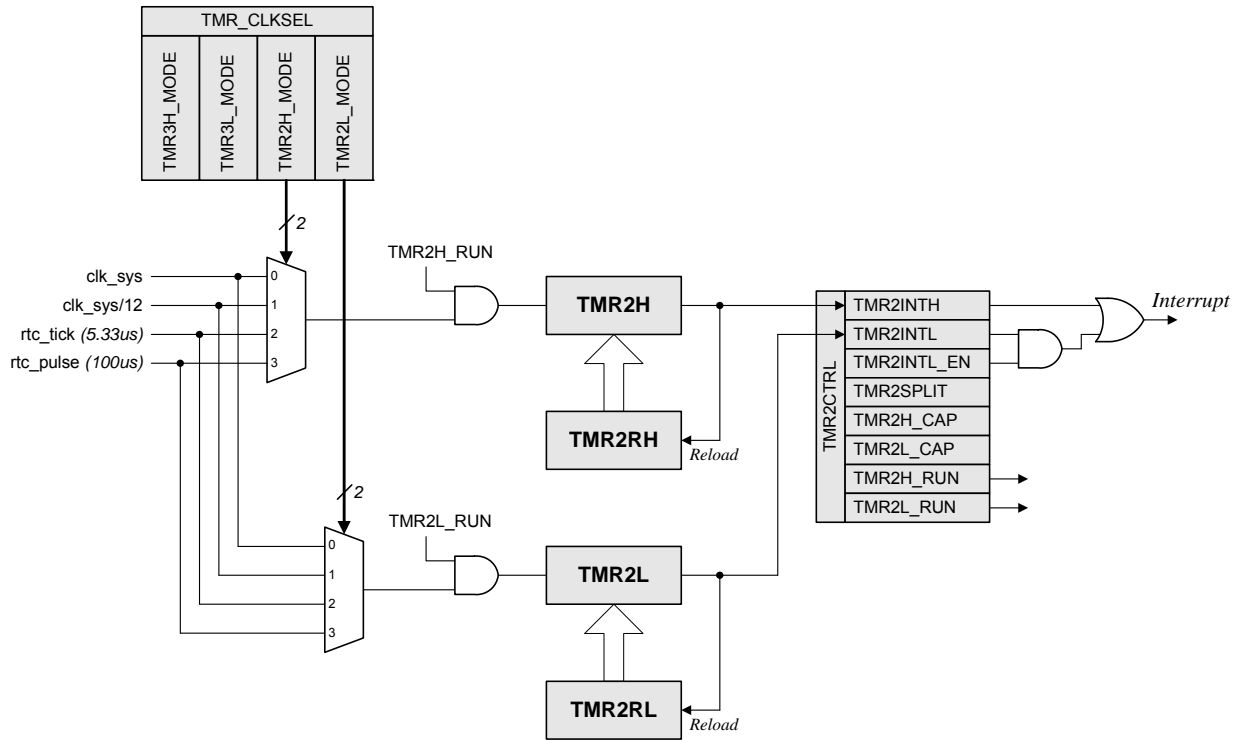

**Figure 34.4. Two 8-bit Timers in Timer/Timer Configuration (Split Mode)**

### 34.5. 8-Bit Capture/Capture Mode (Split Mode)

When  $TMR2SPLIT=1$ ,  $TMR2L\_CAP=1$  and  $TMR2H\_CAP=1$ , both halves operate independently in 8-bit capture modes. However, the capture event is the same for both timers. The clock sources for each timer are selected independently, so one timer can capture short pulses while the other one long pulses, for example.

Each 8-bit timer is free running, counts up and overflows from 0xFF to 0x00. Each time a capture event is received, the contents of the timer registers (TMR2H and TMR2L) are latched into the corresponding timer reload registers (TMR2RH and TMR2RL). Common capture event INT0 (INT1 for Timer 3) sets both high and low half interrupt flags TMR2INTH and TMR2INTL at the same time.

The capture event can also generate its own external interrupt on top of the timer interrupt, if enabled by the application. If the capture timer is stopped ( $TMR2L\_RUN=0$ ), the capture event still captures the current counter register TMR2L into the reload register TMR2RL and sets the flag TMR2INTL. Same independently applies to the upper half TMR2H with its respective registers and flags.

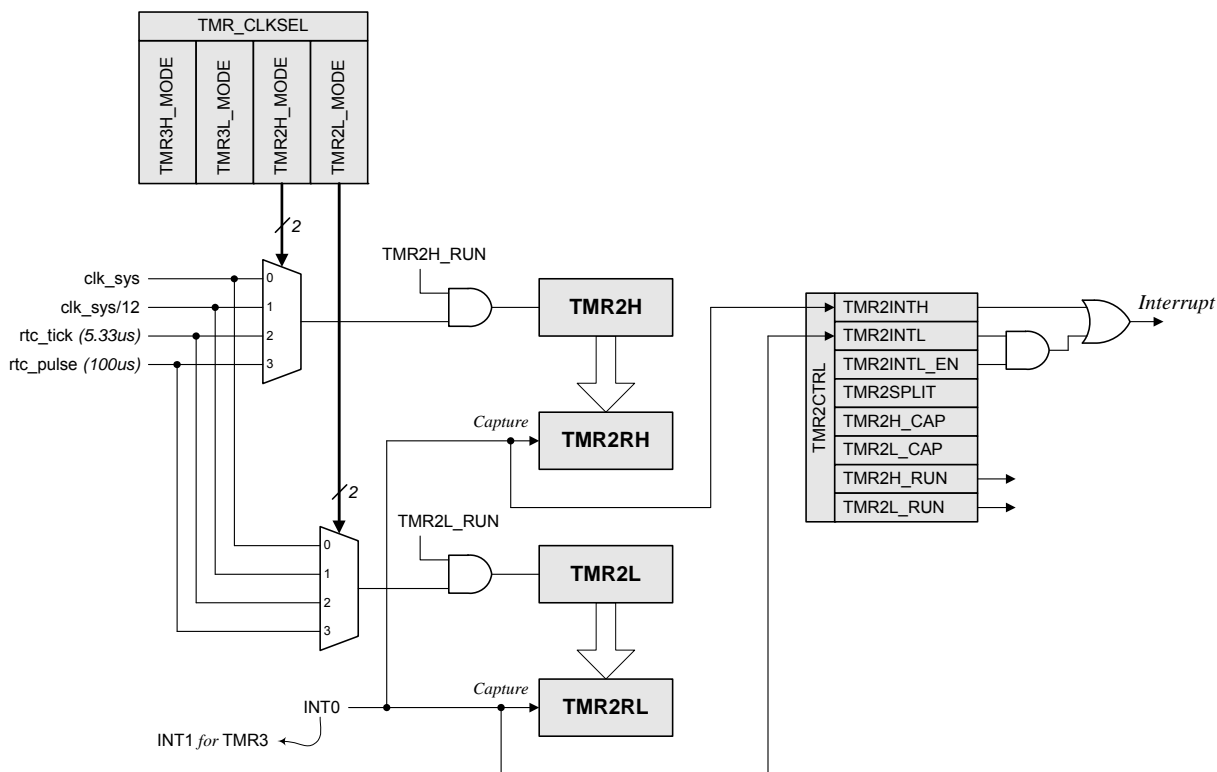

**Figure 34.5. Two 8-bit Timers in Capture/Capture Configuration (Split Mode)**

### 34.6. 8-Bit Timer/Capture Mode (Split Mode)

When TMR2SPLIT=1, TMR2L\_CAP=1 and TMR2H\_CAP=0, the split timers operate one in 8-bit timer mode and the other in 8-bit capture mode. Same situation happens when TMR2L\_CAP=0 and TMR2H\_CAP=1, only the roles of the timer 8-bit halves are reversed. The only difference in between these two scenarios are the interrupt flags settings, since TMR2INTH and TMR2INTL are not symmetrical. The TMR2INTL has a local enable TMR2INTL\_EN. The functionality of the 8-bit timer and 8-bit capture modes for the respective halves is the same as described above when both halves operate in the same mode.

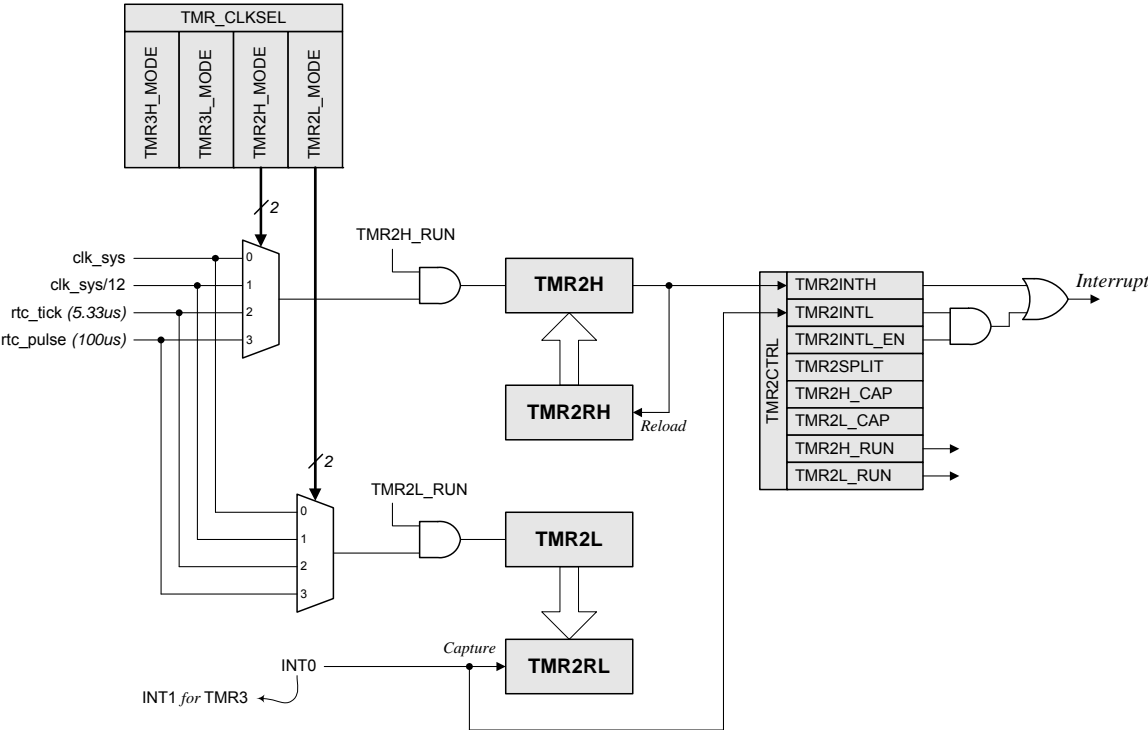
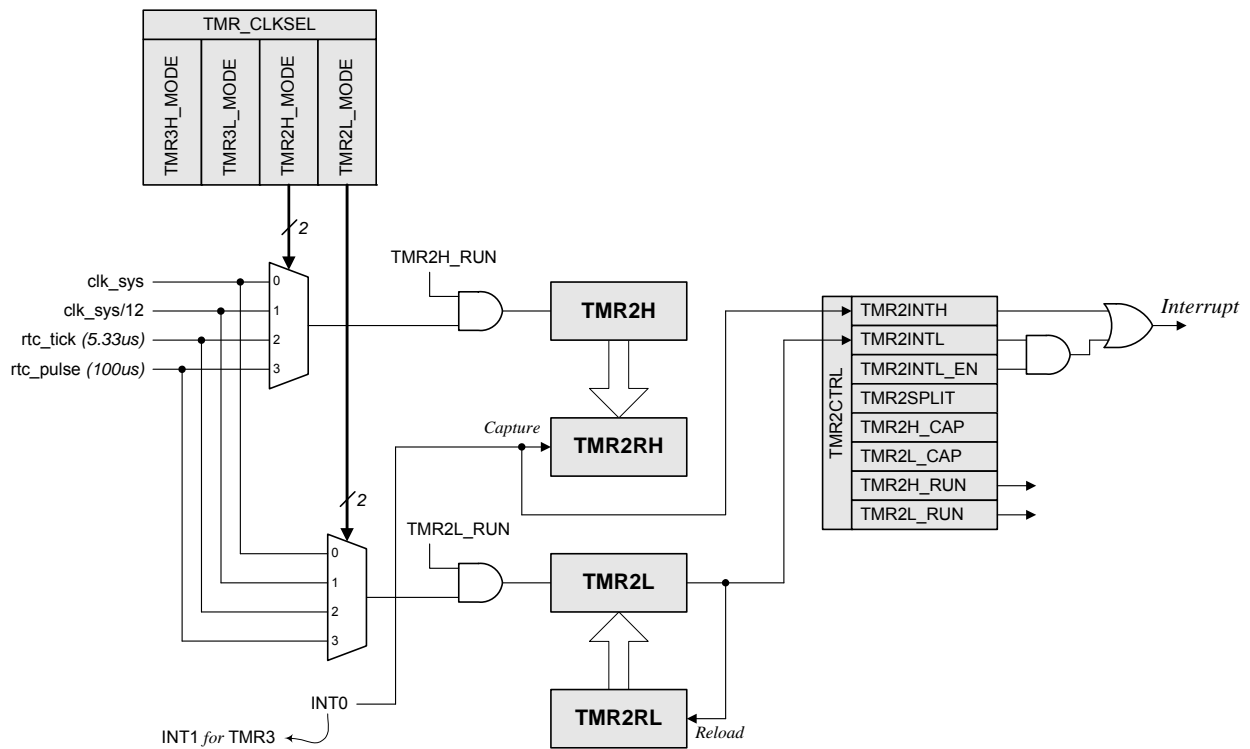

Figure 34.6. Two 8-Bit Timers in Timer/Capture Configuration (Split Mode)



**Figure 34.7. Two 8-Bit Timers In Capture/Timer Configuration (Split Mode)**

---

**SFR Definition 34.1. TMR\_CLKSEL**

---

Bit	7	6	5	4	3	2	1	0
Name	TMR3H_MODE		TMR3L_MODE		TMR2H_MODE		TMR2L_MODE	
Type	R/W		R/W		R/W		R/W	
Reset	0	0	0	0	0	0	0	0

SFR Address = 0xC9

Bit	Name	Function
7:6	TMR3H_MODE	<b>Timer 3 High Byte Mode Select.</b> Timer 3 high half in split mode. Ignored if Timer 3 is in wide mode. 00: CLK_SYS 01: CLK_SYS/12 10: RTC_TICK = 5.33 $\mu$ s 11: RTC_PULSE = 100 $\mu$ s
5:4	TMR3L_MODE	<b>Timer 3 Low Byte Mode Select.</b> Timer 3 low half in split mode or full timer in wide mode clock selection. 00: CLK_SYS 01: CLK_SYS/12 10: RTC_TICK = 5.33 $\mu$ s 11: RTC_PULSE = 100 $\mu$ s
3:2	TMR2H_MODE	<b>Timer 2 High Byte Mode Select.</b> Timer 2 high half in split mode. Ignored if Timer 2 is in wide mode. 00: CLK_SYS 01: CLK_SYS/12 10: RTC_TICK = 5.33 $\mu$ s 11: RTC_PULSE = 100 $\mu$ s
1:0	TMR2L_MODE	<b>Timer 2 Low Byte Mode Select.</b> Timer 2 low half in split mode or full timer in wide mode clock selection. 00: CLK_SYS 01: CLK_SYS/12 10: RTC_TICK = 5.33 $\mu$ s 11: RTC_PULSE = 100 $\mu$ s

# Si4010-C2

## SFR Definition 34.2. TMR2CTRL

Bit	7	6	5	4	3	2	1	0
Name	TMR2 INTH	TMR2 INTL	TMR2 INTL_EN	TMR2 SPLIT	TMR2H_ CAP	TMR2L_ CAP	TMR2H_ RUN	TMR2L_ RUN
Type	R/W	R/W	R/W	R/W	R/W	R/W	R/W	R/W
Reset	0	0	0	0	0	0	0	0

SFR Address = 0xC8; Bit-Addressable

Bit	Name	Function
7	TMR2 INTH	<b>Timer 2 High Byte Interrupt Flag.</b> Interrupt flag for timer high half in split configuration or overall 16 bit timer in wide configuration. It gets set when the high half of the timer overflows or there is a capture event for the high half. This bit is not automatically cleared by hardware.
6	TMR2 INTL	<b>Timer 2 Low Byte Overflow Flag.</b> Interrupt flag for the timer low half. It gets set when the low half overflows in timer mode or by capture event of the low half in capture mode. Software must clear this bit, hardware will not clear it. This bit is set when the low half of the timer overflows even if we operate in wide configuration. When in wide configuration and in capture mode this bit is set when the high half of the timer overflows. Since in that case the capture event is the same for both halves, the capture event sets the TMR2INTH interrupt flag. Then this TMR2INTL can be used as a flag that the timer overflow, serving as an additional 17th timer bit in capture mode in wide configuration.
5	TMR2 INTL_EN	<b>Timer 2 Low Byte Interrupt Enable.</b> When set to 1, this bit enables Timer 2 Low Byte interrupts. The overall timer interrupt request signal is : TMR2 interrupt request = TMR2INTH   (TMR2INTL & TMR2INTL_EN)
4	TMR2 SPLIT	<b>Timer 2 Split Mode Enable.</b> 0: Timer operates in wide configuration as 16 bit timer. The low half controls the whole timer. 1: Timer operates in split configuration. Both halves are controlled independently.
3	TMR2H_ CAP	<b>Timer 2 High Byte Capture Mode Enable.</b> If set then TMR2H high half operates in capture mode if the timer is in split configuration mode. Ignored if the timer operates in wide configuration mode.
2	TMR2L_ CAP	<b>Timer 2 Low Byte Capture Mode Enable.</b> If set then TMR2L low half operates in capture mode if the timer is in split configuration, or the whole timer operates in capture mode if in wide configuration mode.

Bit	Name	Function
1	TMR2H_ RUN	<b>Timer 2 High Byte Run Model.</b> TMR2H high byte enable in split configuration. Ignored if timer operates in wide configuration.
0	TMR2L_ RUN	<b>Timer 2 Low Byte Run Model.</b> TMR2L low byte enable in split configuration, whole timer enable in wide configuration.

# Si4010-C2

---

## SFR Definition 34.3. TMR2RL

---

Bit	7	6	5	4	3	2	1	0
Name	TMR2RL[7:0]							
Type	R/W							
Reset	0	0	0	0	0	0	0	0

SFR Address = 0xCA

Bit	Name	Function
7:0	TMR2RL[7:0]	<b>Timer 2 Capture/Reload Register Low Byte.</b> TMR2RL holds the low byte of the capture/reload value for Timer 2. LSB Byte. Two halves are not double buffered. Write to each of the halves takes effect immediately. If the timer or respective half operates in capture mode this register holds the capture value. If the timer or respective half operates in timer mode this register holds the reload value.

---

## SFR Definition 34.4. TMR2RH

---

Bit	7	6	5	4	3	2	1	0
Name	TMR2RH[7:0]							
Type	R/W							
Reset	0	0	0	0	0	0	0	0

SFR Address = 0xCB

Bit	Name	Function
7:0	TMR2RH[7:0]	<b>Timer 2 Capture/Reload Register High Byte.</b> TMR2RH holds the high byte of the reload value for Timer 2.



**SFR Definition 34.5. TMR2L**

Bit	7	6	5	4	3	2	1	0
Name	TMR2L[7:0]							
Type	R/W							
Reset	0	0	0	0	0	0	0	0

SFR Address = 0xCC

Bit	Name	Function
7:0	TMR2L[7:0]	<b>Timer 2 Low Byte Actual Timer Value.</b> In 16-bit mode, the TMR2L register contains the low byte of the 16-bit Timer 2. In 8-bit mode, TMR2L contains the 8-bit low byte timer value.

**SFR Definition 34.6. TMR2H**

Bit	7	6	5	4	3	2	1	0
Name	TMR2H[7:0]							
Type	R/W							
Reset	0	0	0	0	0	0	0	0

SFR Address = 0xCD

Bit	Name	Function
7:0	TMR2H[7:0]	<b>Timer 2 High Byte Actual Timer Value.</b> In 16-bit mode, the TMR2H register contains the high byte of the 16-bit Timer 2. In 8-bit mode, TMR2H contains the 8-bit high byte timer value.

# Si4010-C2

## SFR Definition 34.7. TMR3CTRL

Bit	7	6	5	4	3	2	1	0
Name	TMR3 INTH	TMR3 INTL	TMR3 INTL_EN	TMR3 SPLIT	TMR3H_ CAP	TMR3L_ CAP	TMR3H_ RUN	TMR3L_ RUN
Type	R/W	R/W	R/W	R/W	R/W	R/W	R/W	R/W
Reset	0	0	0	0	0	0	0	0

SFR Address = 0xB9

Bit	Name	Function
7	TMR3 INTH	<b>Timer 3 High Byte Interrupt Flag.</b> Interrupt flag for timer high half in split configuration or overall 16 bit timer in wide configuration. It gets set when the high half of the timer overflows or there is a capture event for the high half. This bit is not automatically cleared by hardware.
6	TMR3 INTL	<b>Timer 3 Low Byte Overflow Flag.</b> Interrupt flag for the timer low half. It gets set when the low half overflows in timer mode or by capture event of the low half in capture mode. Software must clear this bit, hardware will not clear it. This bit is set when the low half of the timer overflows even if we operate in wide configuration. When in wide configuration and in capture mode this bit is set when the high half of the timer overflows. Since in that case the capture event is the same for both halves, the capture event sets the TMR3INTH interrupt flag. Then this TMR3INTL can be used as a flag that the timer overflowed, serving as an additional 17th timer bit in capture mode in wide configuration.
5	TMR3 INTL_EN	<b>Timer 3 Low Byte Interrupt Enable.</b> When set to 1, this bit enables Timer 3 Low Byte interrupts. The overall timer interrupt request signal is : TMR3 interrupt request = TMR3INTH   (TMR3INTL & TMR3INTL_EN)
4	TMR3 SPLIT	<b>Timer 3 Split Mode Enable.</b> 0: Timer operates in wide configuration as 16 bit timer. The low half controls the whole timer. 1: Timer operates in split configuration. Both halves are controlled independently.
3	TMR3H_ CAP	<b>Timer 3 High Byte Capture Mode Enable.</b> If set then TMR3H high half operates in capture mode if the timer is in split configuration mode. Ignored if the timer operates in wide configuration mode.
2	TMR3L_ CAP	<b>Timer 3 Low Byte Capture Mode Enable.</b> If set then TMR3L low half operates in capture mode if the timer is in split configuration, or the whole timer operates in capture mode if in wide configuration mode.

Bit	Name	Function
1	TMR3H_ RUN	<b>Timer 3 High Byte Run Model.</b> TMR3H high byte enable in split configuration, whole timer enable in wide configuration.
0	TMR3L_ RUN	<b>Timer 3 Low Byte Run Model.</b> TMR3L low byte enable in split configuration, whole timer enable in wide configuration.

# Si4010-C2

---

## SFR Definition 34.8. TMR3RL

---

Bit	7	6	5	4	3	2	1	0
Name	TMR3RL[7:0]							
Type	R/W							
Reset	0	0	0	0	0	0	0	0

SFR Address = 0xBA

Bit	Name	Function
7:0	TMR3RL[7:0]	<b>Timer 3 Capture/Reload Register Low Byte.</b> TMR3RL holds the low byte of the capture/reload value for Timer 3. LSB Byte. Two halves are not double buffered. Write to each of the halves takes effect immediately. If the timer or respective half operates in capture mode this register holds the capture value. If the timer or respective half operates in timer mode this register holds the reload value.

---

## SFR Definition 34.9. TMR3RH

---

Bit	7	6	5	4	3	2	1	0
Name	TMR3RH[7:0]							
Type	R/W							
Reset	0	0	0	0	0	0	0	0

SFR Address = 0xBB

Bit	Name	Function
7:0	TMR3RH[7:0]	<b>Timer 3 Capture/Reload Register High Byte.</b> TMR3RH holds the high byte of the reload value for Timer 3.

**SFR Definition 34.10. TMR3L**

Bit	7	6	5	4	3	2	1	0
Name	TMR3L[7:0]							
Type	R/W							
Reset	0	0	0	0	0	0	0	0

SFR Address = 0xBC

Bit	Name	Function
7:0	TMR3L[7:0]	<b>Timer 3 Low Byte Actual Timer Value.</b> In 16-bit mode, the TMR3L register contains the low byte of the 16-bit Timer 3. In 8-bit mode, TMR3L contains the 8-bit low byte timer value.

**SFR Definition 34.11. TMR3H**

Bit	7	6	5	4	3	2	1	0
Name	TMR3H[7:0]							
Type	R/W							
Reset	0	0	0	0	0	0	0	0

SFR Address = 0xBD

Bit	Name	Function
7:0	TMR3H[7:0]	<b>Timer 3 High Byte Actual Timer Value.</b> In 16-bit mode, the TMR3H register contains the high byte of the 16-bit Timer 3. In 8-bit mode, TMR3H contains the 8-bit high byte timer value.

## 35. C2 Interface

The devices include an on-chip Silicon Laboratories 2-Wire (C2) debug interface in-system debugging with the production part installed in the end application. The C2 interface uses a clock signal (C2CLK) and a bi-directional C2 data signal (C2DAT) to transfer information between the device and a host system. The C2 interface is intended to be used by the Silicon Labs or third party development tools. It is not intended to be used for any other purpose. It can be completely disabled per user programming for fully programmed chips.

### 35.1. C2 Pin Sharing

The C2 protocol allows the C2 pins to be shared with user functions so that in-system debugging. This is possible because C2 communication is typically performed when the device is in the halt state, where all on-chip peripherals and user software are stalled. In this halted state, the C2 interface can safely borrow the C2CLK (GPIO[5]) and C2DAT (GPIO[4]) pins. In most applications, external resistors are required to isolate C2 interface traffic from the user application. A typical isolation configuration is shown in Figure 35.1 along with the connection to the standard Silicon Labs 10-pin debugging interface header.

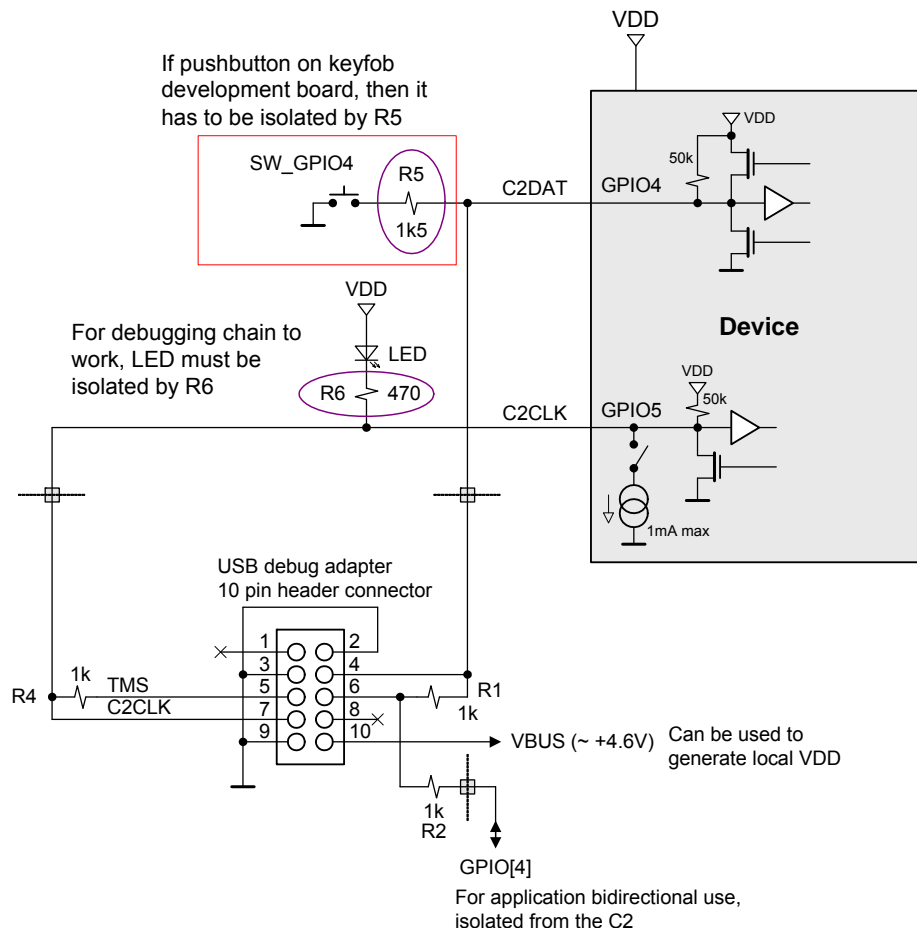

Figure 35.1. 10-pin C2 USB Debugging Adapter Connection to Device

# Si4010-C2

---

On this device the GPIO[5] is shared with the LED current driver, which can drive up to 1mA of current to the ground. Normally the LED will be connected in between the GPIO[5] and VDD. For C2 to work the LED driver is disabled during debugging sessions, so even if the user code tries to turn the LED on, that operation will not interfere with C2 debug transactions and the actual LED current driver will not be turned on.

Whenever the user disconnects the IDE from the device by hitting the **Disconnect** button on the IDE, the IDE clears all the breakpoints, clears the LED driver disable (enables the LED), and runs the currently loaded user application residing in the CODE/XDATA RAM from the current position where the code was halted. If IDE is disconnected from the device the user application behaves exactly as programmed, with the LED driver driving the LED per user application. The user then can connect to the device through IDE by hitting the **Connect** button. The connection is only possible when the LED driver is not active. Upon connection the IDE will disable the LED driver for the duration of the debug session (until the device is **Disconnect-ed**).

The GPIO[4] can be used as a bidirectional input/output by a user application, but a resistive network has to be used to isolate the GPIO[4] from the C2 transactions, as shown in Figure 35.1.

Instead of the USB debug adapter the user can also use Silicon Labs ToolStick development tool. The ToolStick has a PCB edge 14 pin connector. Connection in between the device and the ToolStick for software development and debugging is in Figure 35.2.

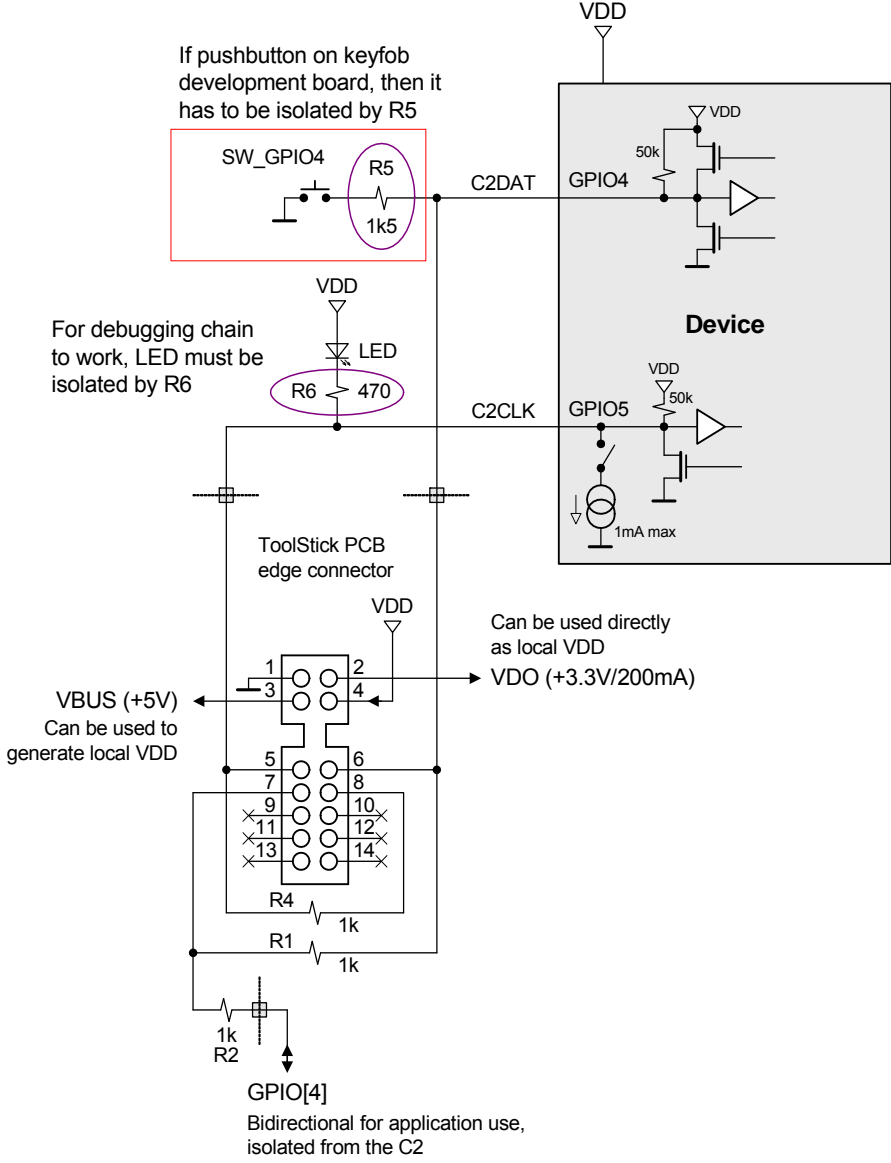

Figure 35.2. 14-Pin C2 ToolStick Connection to Device



## 36. IDE Development Environment and Debugging Chain

The development platform will be provided by Silicon Labs. The debugging chain consists of an evaluation board or an evaluation keyfob, USB debug adapter or a USB based ToolStick, and the Silicon Labs IDE development environment.

The debugging chain is using the C2 two wire interface to provide an on-chip debugging capability. The environment can load the standard OMF-51 object and symbol file only, not any proprietary extensions of that format as used by some tool manufacturers. For example, on Keil platform it means that the BL51 linker must be used. The IDE will not load outputs generated by the Keil LX51 linker. On Raisonance platform the output is the OMF-51 compliant and the file extension is AOF.

The IDE debugging environment has means to reset the chip without cycling the power. By pressing the **Reset** inside of the IDE the digital part of the device is reset and device startup boot sequence is invoked. All registers are reset to their initial states and all of the **Factory** values are refreshed in RAM and registers. If the part is a Factory part, the previously loaded CODE/XDATA RAM content is not disturbed. If the part is a User part then the User data region is loaded as well, overwriting the content of the CODE/XDATA RAM.

Using IDE is the only way to reset the chip without cycling the power to it or shutting it down and waking it up.

### 36.1. Functionality Limitations While Using IDE Development Environment

Even though using the Silicon Labs IDE development environment preserves almost all of the chip functionality, there are some limitations the user should be aware of. Given that the code is running from RAM and that the C2CLK shares the pin with LED output current driver (GPIO[5]), they are two functionality limitations for code development while using IDE:

1. The user cannot put a **Factory** or **User** chip into the shutdown mode and then wake it up by pressing a button (pulling any of the GPIO to ground). When the chip is in shutdown mode, the power to all digital is lost and therefore the RAM content with the user code will get erased.
2. The LED driver cannot be used when the device is connected to the debug adapters (USB debug adapter or a ToolStick).
3. Once the part is finalized, programmed as **Run** part, no further debugging is possible.

## 36.2. Chip Shutdown Limitation

While developing firmware on an unprogrammed chip the user cannot call the API function `vSys_Shutdown()` to shutdown the chip without losing the RAM code downloaded by IDE.

Instead, the user should comment out the call to the shutdown function and replace it with a temporary code, which monitors a button press, actually monitoring P0 and P1 port inputs based on the user current port settings. If the button is pressed (input port value read as 0) then the long jump to address 0x0000 (LJMP 0x0000) should be executed. This would mimic the functionality of the chip shutdown and push button wakeup.

The limitation of this approach is that the digital logic is not reset and the current values of all the digital registers are preserved, while during the real shutdown and wakeup they are asynchronously reset during the process and the whole boot process is invoked.

Therefore, it is advisable not to rely on the reset values of any peripheral control registers and during the user application peripheral initialization the initial value should be forced to the registers by using MOV instructions rather than using ORL and ANL instructions to set or clear particular bits while relying on the SFR registers reset values.

## 36.3. LED Driver Usage while Using IDE Debugging Chain

To maximize utilization of the package pins the LED current driver output is shared with the debug chain clock signal C2CLK on the GPIO[5]. The debugging chain internally disables the LED driver while the device is connected to the debugging adapter. User can develop the code as if the LED were present without interfering with the debugging chain. The LED driver will not get turned on even if the user application code requests the driver to be turned on.

To share the LED and C2CLK functionality on a single pin and be able to use IDE for debugging there are some limitations and rules to follow. Figure 35.1 and Figure 35.2 show the recommended connection of the debug adapters to the device in the user application. Note that the LED must be isolated by the 470 resistor for the debugging chain to work. If the debugging in the user application is not needed then the 470 resistor is not needed either.

Facts about using the LED with IDE chain:

1. The IDE chain can connect to the device only if the LED current driver is off and the LED is not lit.
2. Once the IDE chain is connected to the device it blocks the device LED driver. Therefore, the application can be written in a normal fashion using LED as desired in the final application without worry of being disconnected from the debug chain. The only limitation is that the LED will not be lit from the application during the IDE debug session. The user will still observe LED activity, but that activity is related to the debug chain communicating with the device, not the user application driving the LED.
3. Once the IDE chain is disconnected from the device (by pressing `Disconnect` button in IDE, for example), the device is released from halt and at the same time the blocking of the LED driver is removed. From that point on the application behaves and runs as regular application and the LED activity reflects what the application desires to do with LED.
4. If the user wants to reconnect the IDE to the device the only requirement is that the LED must not be lit by the application at that moment. Therefore, if for whatever reason the device user software is stuck in an infinite loop and driving the LED constantly, the IDE chain will not be able to connect to the device. In such situations the device power has to be cycled to invoke internal power on reset by unplugging the keyfob from the programming or ToolStick boards and replugging again. See item 1. above.

## Si4010-C2

---

For example, on the keyfob battery backed up development platform the user can disconnect the keyfob from the debugging platform (programming board or directly from the ToolSTick) and walk around with running application using LED as desired by the application. The only thing the user has to do is to **Disconnect** the keyfob from the IDE by pressing the **Disconnect** button. The LED gets enabled and the application runs from the point where the application is currently halted. To run the application from the very beginning, the user must press **Reset** on the IDE before pressing **Disconnect**.

---

## 37. Additional Reference Resources

- AN369: Antenna Interface for the Si401x Transmitters
- AN370: Si4010 Software Programming Guide
- AN511: Si4010 NVM Burner user's guide
- AN515: Si4010 Key fob Development Kit Quick-Start Guide
- AN518: Si4010 Memory Overlay Technique
- AN526: Si4010 ROM 02.00 API Additional Library Description
- AN577: Si4010 NVM Read Reliability Analysis

## DOCUMENT CHANGE LIST

### Revision 0.1 to Revision 0.2

- Completely revised data sheet revision 0.1 to include MCU operation
- Reformatted data sheet to correspond with MCU data sheet format
- Removed RKE application, focus on general MCU + Tx usage
- Included 14P SOIC package and pin information
- Updated Section “4. Ordering Information” on page 15
- Updated Section “10. Electrical Characteristics” on page 28

### Revision 0.2 to Revision 0.5

- Updated data sheet for revision B and C silicon
- Changed standby supply current to < 10 nA
- Increase data rate to 100 kBaud for FSK and 50 kBaud for OOK
- Corrected maximum clock frequency of the LPOSC to 24 MHz
- Updated section 2. Ordering Information to reflect the revision B and C silicon
- Updated table 7.3 DC Characteristics to reflect revision B and C silicon
- Updated table 7.4 Si4010 RF Transmitter Characteristics to reflect revision B and C silicon
- Fixed block diagram in figure 8.1. Test Block Diagram with 10-pin MSOP Package
- Updated section 10. System Description text for revision B and C silicon
- Updated section 11. Power Amplifier text for revision B and C silicon
- Updated section 23. System Boot and NVM Programming for revision B and C silicon
- Updated section 36. Additional Reference Resources to include new application notes

### Revision 0.5 to Revision 0.6

- Removed revision B part numbers and replaced with revision C part numbers Si4010-C2-GT and Si4010-C2-GS

### Revision 0.6 to Revision 1.0

- Updated electrical specifications to final values.

---

## CONTACT INFORMATION

### Silicon Laboratories Inc.

Silicon Laboratories Inc.  
400 West Cesar Chavez  
Austin, TX 78701

Please visit the Silicon Labs Technical Support web page:  
<https://www.silabs.com/support/pages/contacttechnicalsupport.aspx>  
and register to submit a technical support request.

The information in this document is believed to be accurate in all respects at the time of publication but is subject to change without notice. Silicon Laboratories assumes no responsibility for errors and omissions, and disclaims responsibility for any consequences resulting from the use of information included herein. Additionally, Silicon Laboratories assumes no responsibility for the functioning of undescribed features or parameters. Silicon Laboratories reserves the right to make changes without further notice. Silicon Laboratories makes no warranty, representation or guarantee regarding the suitability of its products for any particular purpose, nor does Silicon Laboratories assume any liability arising out of the application or use of any product or circuit, and specifically disclaims any and all liability, including without limitation consequential or incidental damages. Silicon Laboratories products are not designed, intended, or authorized for use in applications intended to support or sustain life, or for any other application in which the failure of the Silicon Laboratories product could create a situation where personal injury or death may occur. Should Buyer purchase or use Silicon Laboratories products for any such unintended or unauthorized application, Buyer shall indemnify and hold Silicon Laboratories harmless against all claims and damages.

Silicon Laboratories and Silicon Labs are trademarks of Silicon Laboratories Inc.  
Other products or brandnames mentioned herein are trademarks or registered trademarks of their respective holders