

Infrared Hydrocarbon Gas Detector
 PointWatch Eclipse™
 Model PIRECL

**DESCRIPTION**

The Pointwatch Eclipse Model PIRECL is a diffusion-based, infrared combustible gas detector that provides continuous, fixed monitoring of flammable hydrocarbon gases from 0 to 100% Lower Explosive Limit (LEL). Standard device outputs include an electrically isolated 4 to 20 mA signal with HART communication protocol, and RS-485 serial communication. Serial communication protocols supported include MODBUS and ASCII.



Ideally suited for protection of challenging on/offshore oil and gas facilities and other downstream hydrocarbon applications, the PointWatch Eclipse is globally certified for use in Class I, Divisions 1 and 2, and Zone 1 hazardous areas. In addition, the stainless steel construction, sapphire optics, and modular design all combine to deliver industrial grade hardness along with easy installation and the lowest cost of ownership available.

The PointWatch Eclipse is capable of detecting hundreds of flammable hydrocarbon vapors. Field-selectable algorithms are provided for methane (default), ethane, propane, butane, ethylene, and propylene. Numerous additional operating parameters are programmable via digital communications or the optional hand-held communicator.

FEATURES AND BENEFITS

- Superior optics protection system.
- No undisclosed failure modes.
- Routine calibration not required.
- Explosion-proof, stainless steel housing with tethered weather protection baffle.
- Integral wiring compartment eliminates need for external junction boxes.
- Built-in tri-color LED eliminates need for external display module.
- Built-in optional relay package eliminates need for external relay output module.
- Optional hand-held HART communicator enables field configuration and calibration.
- Heated sapphire optics deliver long-lasting, high performance detection capability.
- Immune to damage from exposure to constant background gases or to high gas concentrations.
- FM, CSA, CENELEC and CE (including ATEX 94/9/EC) certifications.
- Certified to FM/CSA Div. 1 and CENELEC EEx d, e protection standards for maximum versatility.
- Gas performance verification by FM/CSA/CENELEC.

SPECIFICATIONS

Input Voltage	24 VDC nominal. Operating range is 18 to 32 VDC including ripple.		
Power Consumption	4.0 watts nominal @ 24 VDC 7.5 watts maximum @ 24 VDC 10 watts maximum @ 32 VDC.		
Short Circuit Current	Isc: 5.4 amperes. Isc (fuse): 3.1 amperes.		
Warmup Time	Two minutes from cold power-up to normal mode; 1 hour minimum recommended.		
Current Output	Linear 4 to 20 ma (current source/sink, isolated/non-isolated) rated at 600 ohms maximum loop resistance @ 24 VDC operating voltage.		
Detection Range	0 to 100% LEL standard. Other ranges are configurable.		
Detectable Gases	Most flammable hydrocarbon vapors are detectable. Standard gases include methane, ethane, ethylene, propane, butane and propylene. Detection of non-standard gases is configurable using the HC275 HART communicator.		
Calibration	All units are methane-calibrated at the factory. Device configuration is required for detection of vapors other than methane.		
Device Configuration	Configuration parameters include tag number, measurement range, signal processing algorithm, alarm levels, and other selectable parameters.		
Response Time (With Baffle Installed)		T50	T60
	Without Hydrophobic Filter:	3	4
	With Hydrophobic Filter:	6	7
Temperature Range	Operating: -40°C to +75°C (-40°F to +167°F). Storage: -55°C to +85°C (-67°F to +185°F).		
Humidity (non-condensing)	0 to 99% R.H. (Det-Tronics verified). 5 to 95% R.H. (FM/CSA/CENELEC verified).		
Alarm Setpoint Range	Low Alarm: 5 to 60% LEL High Alarm: 5 to 60% LEL.		
Accuracy	±3% from 0 to 50% LEL, ±5% from 51 to 100% LEL.		
Self-Diagnostic Test	All critical tests performed once per second.		
Ingress Protection	IP66 (CENELEC Verified).		
Detector Housing Material	CF8M stainless steel.		
Conduit Entry Options	Two entries, 3/4 inch NPT or 25 mm.		
HART Communicator Port	Explosion-proof (FM/CSA) Intrinsically safe (CENELEC/CE).		

Optics Protection Weather baffle assembly is Polythalamide plastic, UV-resistant, static dissipating black. Optional internal hydrophobic filter recommended for areas with high levels of airborne particulates or humidity.

Visual Status Indicator Tri-color LED: Red = alarm
Green = power on / OK
Yellow = fault.

Wiring Terminals Field wiring screw terminals are UL/CSA rated for 14 to 24 AWG wire, and are DIN/VDE rated for 2.5 mm² wire. Screw terminal required torque range is 0.4-0.5 N-m. Wiring compartment is dual rated Explosion-proof (Div. 1) & Increased Safety (EEx e).

Certifications



FM & CSA: Class I, Div. 1, Groups C & D (T4)
Class I, Div. 2, Groups A, B, C & D (T4).

CENELEC: DEMKO 01 ATEX 129485X.
EEx d e [ib] IIC T6
(Tamb -40°C to +40°C)
EEx d e [ib] IIC T5
(Tamb -40°C to +50°C)
EEx d e [ib] IIC T4
(Tamb -40°C to +75°C).
IP66.

Intrinsically Safe HART Port:
Uo = 4.0 V
Io = 100 mA
Co = 20 µF
Lo = 500 nH.



CE: Conforms to:
Low Voltage Directive: 73/23/EEC,
EMC Directive: 89/336/EEC,
ATEX Directive: 94/9/EC.

Shipping Weight 7.5 pounds (3.4 kg).

Dimensions

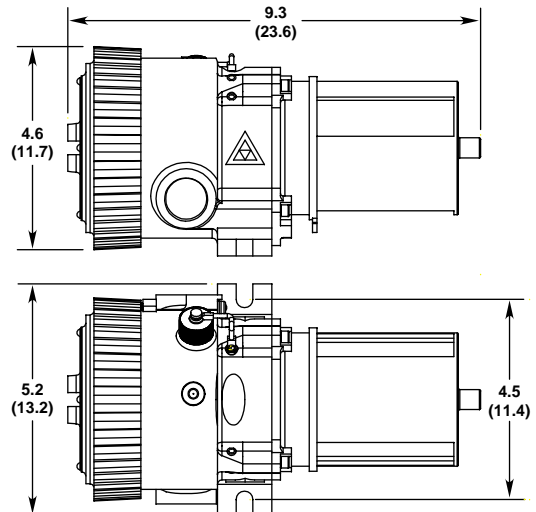

A2055



Detector Electronics Corporation

6901 West 110th Street • Minneapolis, Minnesota 55438 USA
Operator: (952) 941-5665 or (800) 765-FIRE
Customer Service: (952) 946-6491 • Fax (952) 829-8750
<http://www.detrionics.com> • E-mail: detrionics@detrionics.com

Specifications subject to change without notice.