

# How to drive a unipolar stepper motor with the TLE8110ED

**Product Family: Flex Multichannel Low Side Switches**

## About this document

### Scope and purpose

This Application Note demonstrates the behavior of the TLE8110ED in interaction with a unipolar EGR stepper motor. It describes the different various operating modes of the stepper motor. In each mode, the TLE8110ED has to control the motor without triggering undesirable diagnosis entries.

The TLE8110ED provides a unique diagnostic feature called Diagnosis Blind Time which enables the device to meet this requirement. This Application Note also illustrates the differences between the two main types of stepper motors.

The TLE8110ED is a member of the Flex Multichannel Low Side Switches family; it is a smart 10 channel low side switch for engine management loads (injectors, coils, relays, stepper motors, etc.).

For more detailed information about the device itself please refer to the TLE8110ED data sheet.

### Intended audience

This document is intended for anyone considering to use the TLE8110ED in interaction with a unipolar EGR stepper motor.

## Table of Contents

	<b>About this document</b> .....	<b>1</b>
	<b>Table of Contents</b> .....	<b>2</b>
<b>1</b>	<b>Introduction</b> .....	<b>3</b>
1.1	Table of abbreviations .....	3
1.2	Comparison between bipolar and unipolar stepper motor .....	3
1.3	The Blind Time Functionality of the TLE8110ED .....	4
1.4	The Reverse Current Protection Functionality of the TLE8110ED .....	5
<b>2</b>	<b>TLE8110ED behavior driving a unipolar EGR stepper motor</b> .....	<b>7</b>
2.1	Normal operating mode .....	7
2.1.1	Circuit .....	7
2.1.2	Diagnosis .....	7
2.1.3	Analysis .....	7
2.1.4	Summary .....	10
2.2	Stopping the stepper motor .....	10
2.2.1	Circuit .....	10
2.2.2	Diagnosis .....	11
2.2.3	Analysis .....	11
2.2.4	Summary .....	13
<b>3</b>	<b>Driving an EGR stepper motor at battery voltages below 8 V</b> .....	<b>14</b>
3.1	Circuit .....	14
3.2	Diagnosis .....	14
3.3	Analysis .....	14
3.4	Summary .....	21
<b>4</b>	<b>Conclusion</b> .....	<b>22</b>
<b>5</b>	<b>Additional Information</b> .....	<b>23</b>
5.1	Short product characteristics for the used stepper motor .....	23
<b>6</b>	<b>Existing Application Notes</b> .....	<b>24</b>
<b>7</b>	<b>Revision History</b> .....	<b>25</b>

## Introduction

# 1 Introduction

### Please be aware:

- All measures in this application note were done accurately but we cannot guarantee the results. This application note may be changed without notice.
- Please refer to the official TLE8110ED data sheet for a detailed technical description.

## 1.1 Table of abbreviations

**Table 1** Abbreviations & meanings

Abbreviation	Meaning
EGR	Exhaust <b>G</b> as <b>R</b> ecirculation
RCP	Reverse <b>C</b> urrent <b>P</b> rotection. Special device setting for the TLE8110ED
DBTx	<b>D</b> iagnosis <b>B</b> lind <b>T</b> ime. Special device setting for the TLE8110ED. Two settings for 2.5 ms (typical) or 5 ms (typical)
HVAC	Heating, <b>V</b> entilating and <b>A</b> ir- <b>C</b> onditioning

## 1.2 Comparison between bipolar and unipolar stepper motor

The stepper motor is an electrically commutated motor. The basic operation principle is that of a synchronous machine, i.e. a magnetic rotor is moving synchronous to the rotating magnetic field.

The key feature of a stepper motor is that it is driven pulse-wise, which leads to the following advantages and disadvantages:

### Advantages of a stepper motor

- Precise positioning without feedback loop due to step-wise operation.
- High torque at low speed or single steps.
- High holding torque.
- High reliability and life-time, no brushes.

### Disadvantages of a stepper motor

- Driver electronics have to be adapted to specific motor type.
- Step loss is possible at excessive torque.
- Oscillation.

In automotive applications, stepper motors are mostly used for low- to medium power positioning applications like HVAC flaps, head light beam leveling, idle-speed bypass or EGR valves.

To specify a stepper motor, the following properties have to be taken into account:

- Number of phases: Two phase motors are the most popular; however three or more phase motors are sometimes used.
- Unipolar or bipolar drive - see **Figure 1**: Bipolar drive requires two H-bridges for driving, but uses the full amount of copper windings, so the motor delivers more torque. Unipolar drive only uses half of the winding, but only requires four low-side switches.
- Current control or voltage control: Medium- and high-performance stepper motors have low-ohmic coils, so the coil current has to be controlled by the stepper-motor driver by means of chopper current control.

## Introduction

Low-power stepper motors have coils with such high resistance that they are simply switched on, so no current control is necessary over a specified supply voltage range.

- The TLE8110ED is designed to support unipolar, constant voltage stepper motor applications. For more information on other stepper motor driver products, please visit [www.infineon.com](http://www.infineon.com).

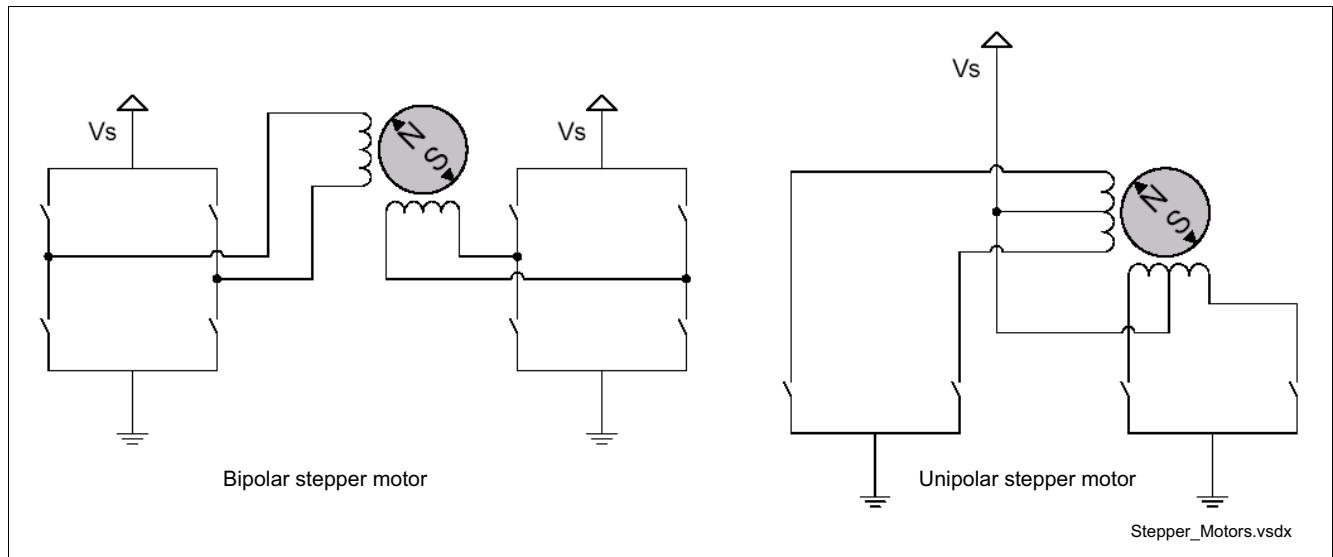

**Figure 1 Stepper motors**

### 1.3 The Blind Time Functionality of the TLE8110ED

In specific application cases, such as driving a unipolar stepper motor, it is possible that reverse currents will flow through a channel. Reverse current occurs when there is a current out of the output instead into the output. This behavior could be when you have an application with inductive loads. This reverse current can disturb the diagnosis circuit in a neighboring channel, causing wrong diagnosis results. To reduce the possibility that this occurs, the fault filter times of channels 7 to 10 can be extended to 2.5 ms (typical) or 5 ms (typical) by setting the “Diagnosis Blind Time” - bits (DEV.DBTx).

In the figure below we see the behavior for the DBT. For more details about this functionality please refer to the data sheet.

Introduction

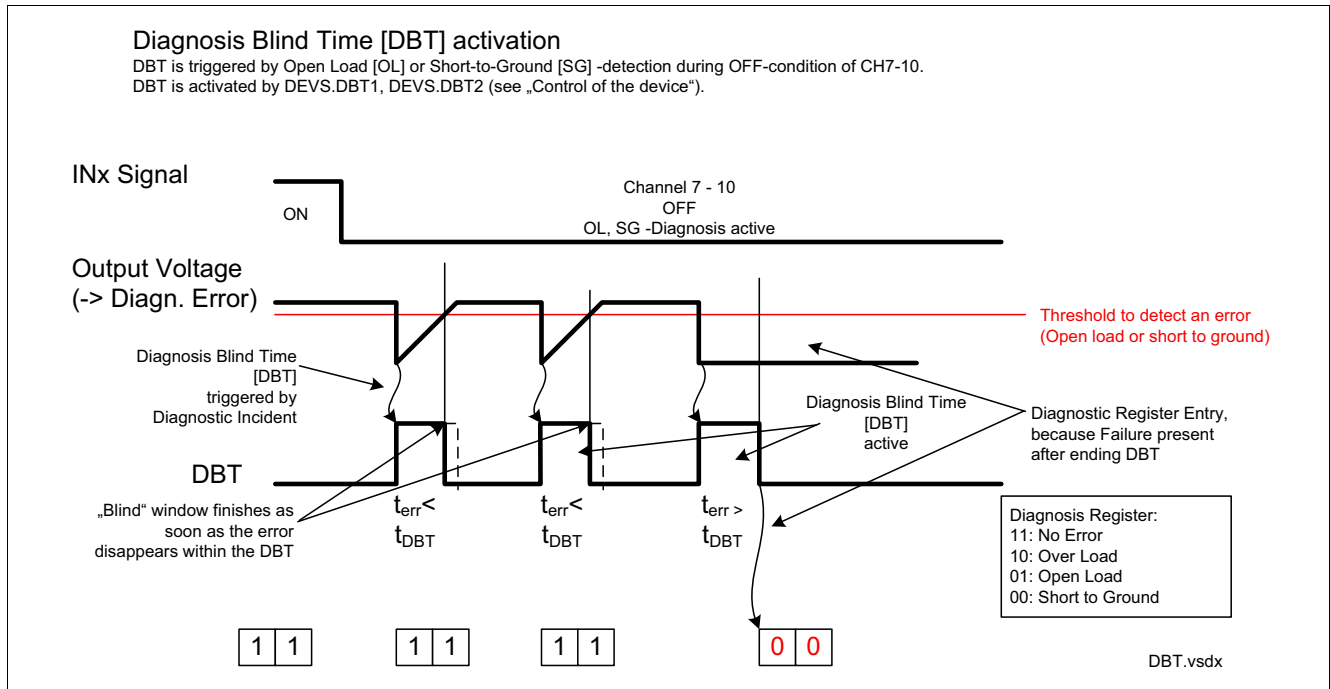

Figure 2 Blind time functionality

1.4 The Reverse Current Protection Functionality of the TLE8110ED

For failure cases that result in reverse currents, the device contains a “Reverse Current Protection Comparator” [RCP]. The RCP feature can be activated by setting the DEVS.RCP bit via the SPI interface. When the RCP feature is activated, a comparator monitors the output voltage. If the output voltage is below -0.3 V, the output transistor is turned on to prevent unwanted substrate current flow. If the reverse current exceeds a certain value, the transistor is turned off, and the current will flow through the body diode of the output transistor. The RCP function will latch the transistor in the off state until the reverse current decays to zero again. Only then can the comparator be activated again after a delay time  $t_{RCP\_on\_delay}$ . This function reduces the un-wanted influence of a reverse current to the analogue part of the circuit (such as the diagnosis).

In the figure below we see the behavior for the RCP. In Figure 4 we see the typical reverse current threshold over temperature for the three channel groups. For more details about this functionality please refer to the data sheet.

Introduction

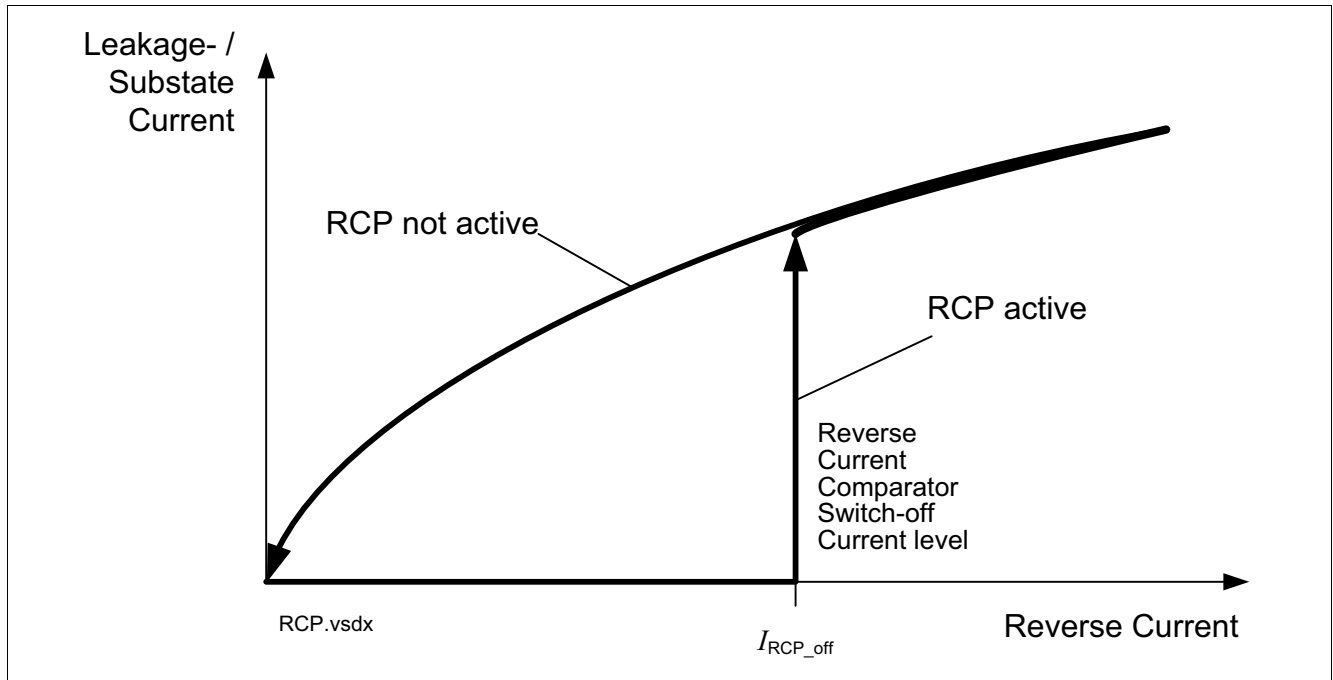

Figure 3 RCP functionality

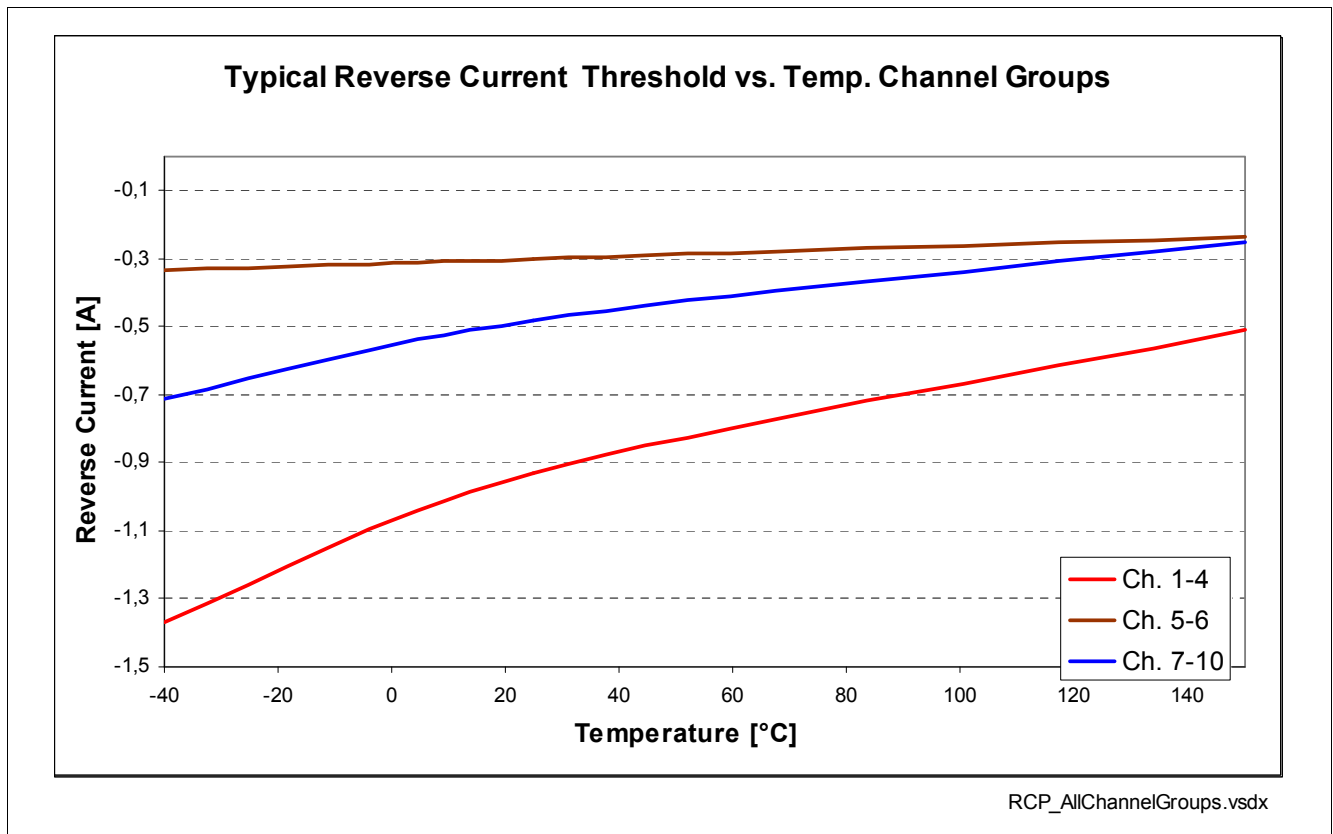

Figure 4 Typical values for the RCP current

## 2 TLE8110ED behavior driving a unipolar EGR stepper motor

### 2.1 Normal operating mode

Several tests with different voltages and temperatures had been done with a unipolar stepper motor. The TLE8110ED controls the EGR stepper motor and no diagnosis errors are stored in the corresponding registers of the TLE8110ED. At least one coil from a coil couple (e.g. one couple is connected to Out 7 and Out 8) is turned on. Stopping the stepper motor is not a normal operating mode (no currents through all coils). This operating mode is described in [Chapter 2.2](#).

#### 2.1.1 Circuit

The figure below shows how the TLE8110ED is connected to a stepper motor. The signals marked in red in this figure are plotted in [Figure 7](#) to [Figure 9](#) (In7, Out 7,  $I_{out7}$  and  $V_{DD}$ ).

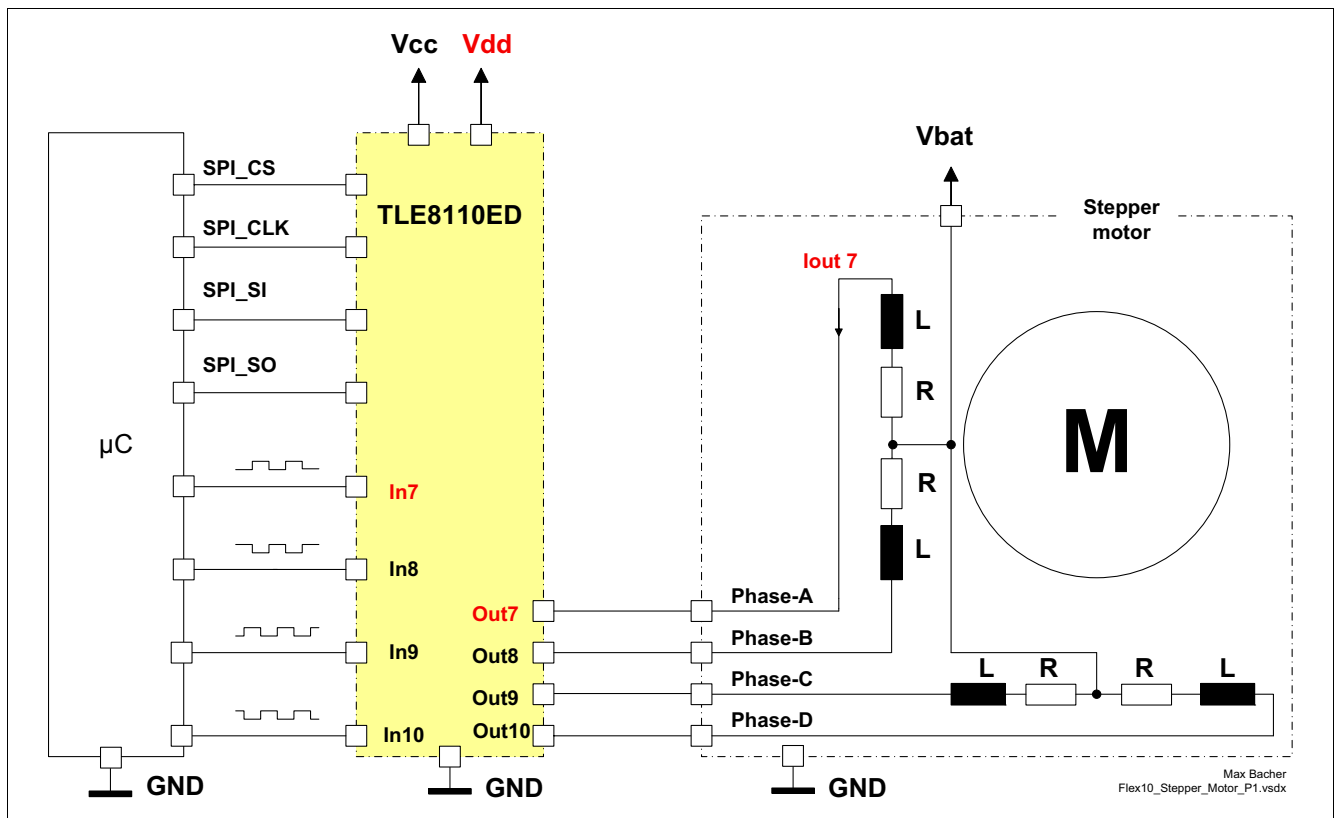

Figure 5 TLE8110ED with stepper motor

#### 2.1.2 Diagnosis

When the stepper is driven in normal operating mode there is no unwanted diagnosis entry. This means we need no special device settings just like DBT or RCB for this operating mode to avoid unwanted diagnosis entries. Normal operating mode is the mode when the coils are supplied with current shown in [Figure 5](#) and  $V_{bat}$  is not below 8 V.

#### 2.1.3 Analysis

The stepper motor is driven with the pattern shown in the figure below. This pattern is repeated continuously. There is always a current flow through one coil at least.

TLE8110ED behavior driving a unipolar EGR stepper motor

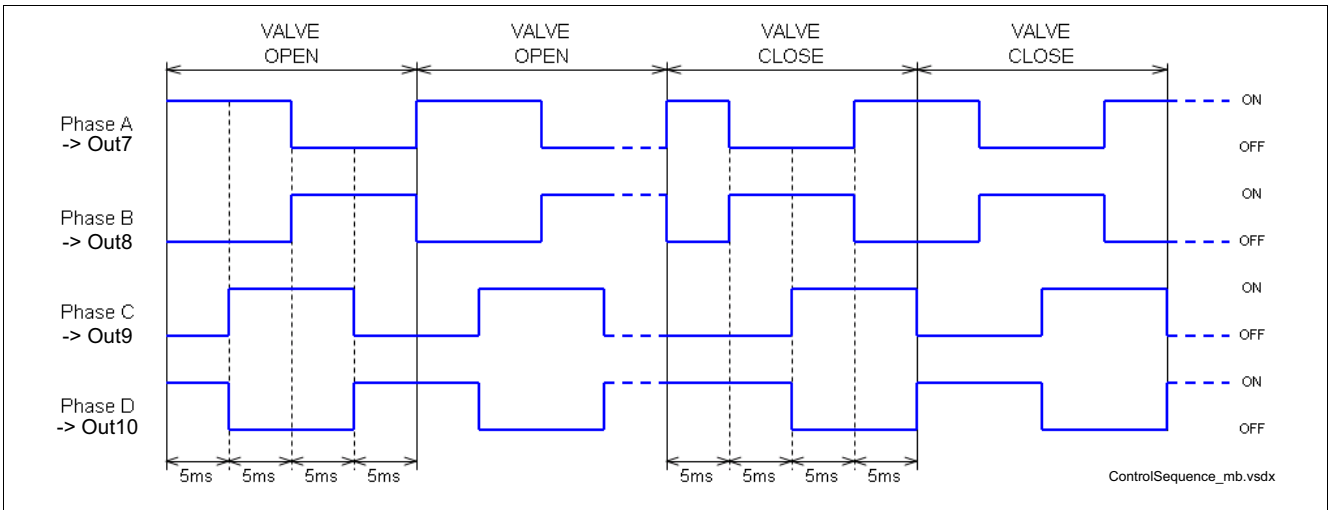

Figure 6 Control sequence

Figure 7 through Figure 9 show the unproblematic interaction of the TLE8110ED with the unipolar stepper motor. The test conditions are various voltages from  $V_{DD}$ ,  $V_{CC}$ ,  $V_{Bat}$  and various temperatures. We can see that there is no need for additional device settings to avoid unwanted diagnosis entries.

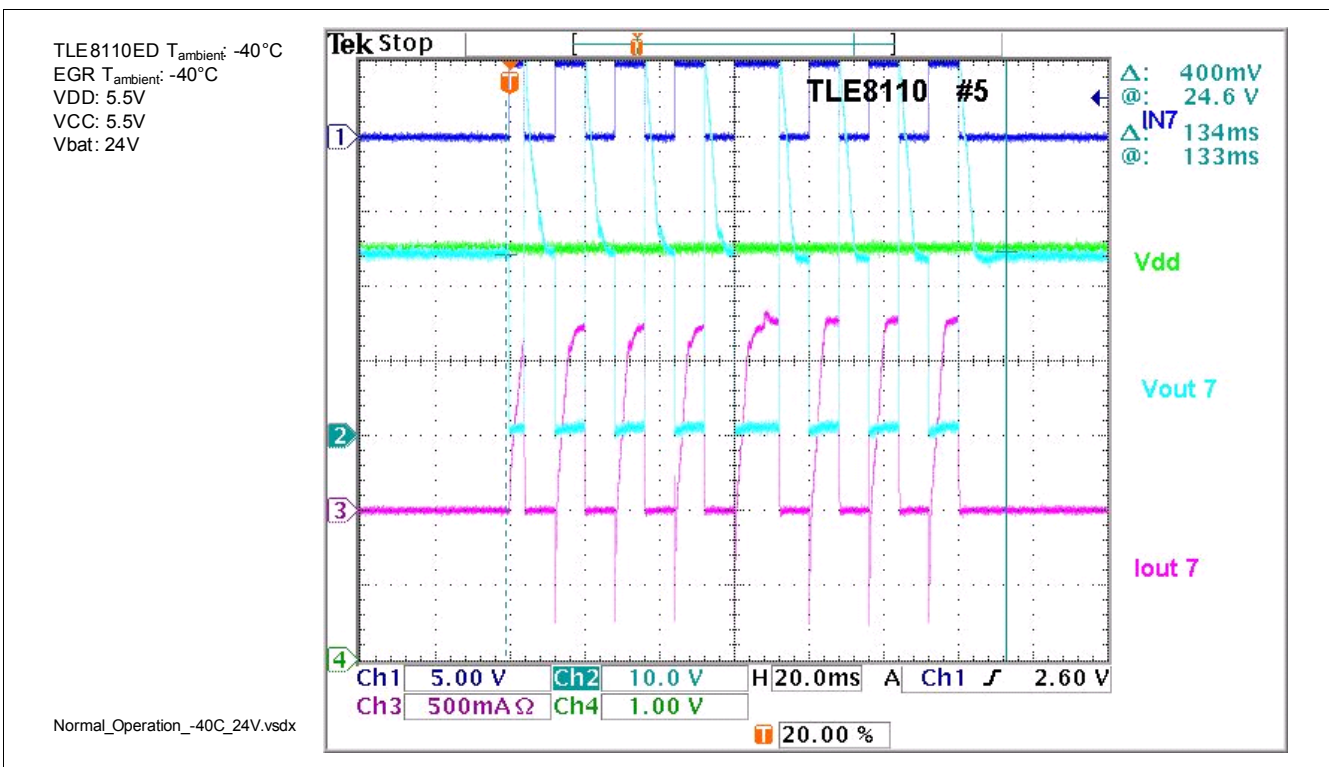

Figure 7 Normal operation mode at worst case boundary conditions ( $T = -40^{\circ}C$ ,  $V_{bat} = 24V$ )



TLE8110ED behavior driving a unipolar EGR stepper motor

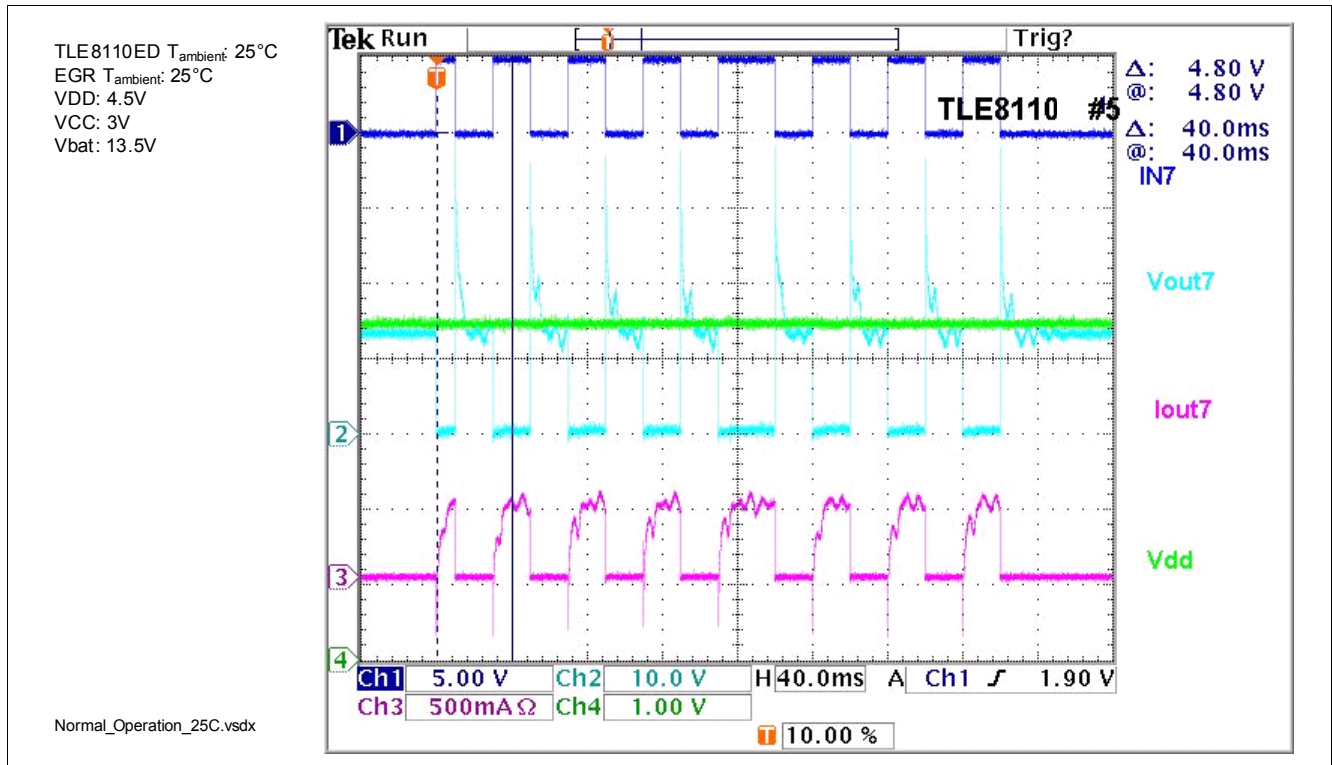

Figure 8 Normal operation mode at low  $V_{CC}$  and  $V_{DD}$  ( $T = 25^\circ\text{C}$ ,  $V_{\text{bat}} = 13.5\text{ V}$ )

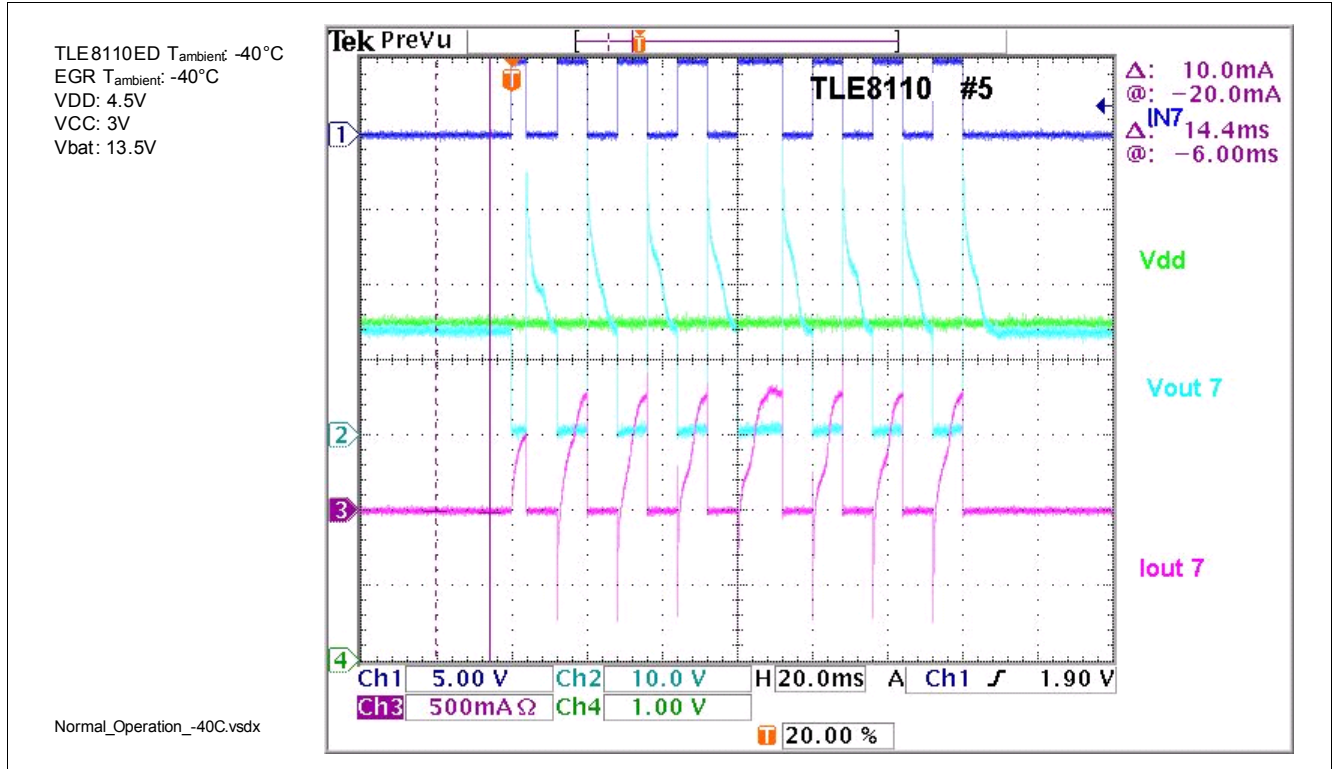

Figure 9 Normal operation mode at low  $V_{CC}$  and  $V_{DD}$  ( $T = -40^\circ\text{C}$ ,  $V_{\text{bat}} = 13.5\text{ V}$ )

TLE8110ED behavior driving a unipolar EGR stepper motor

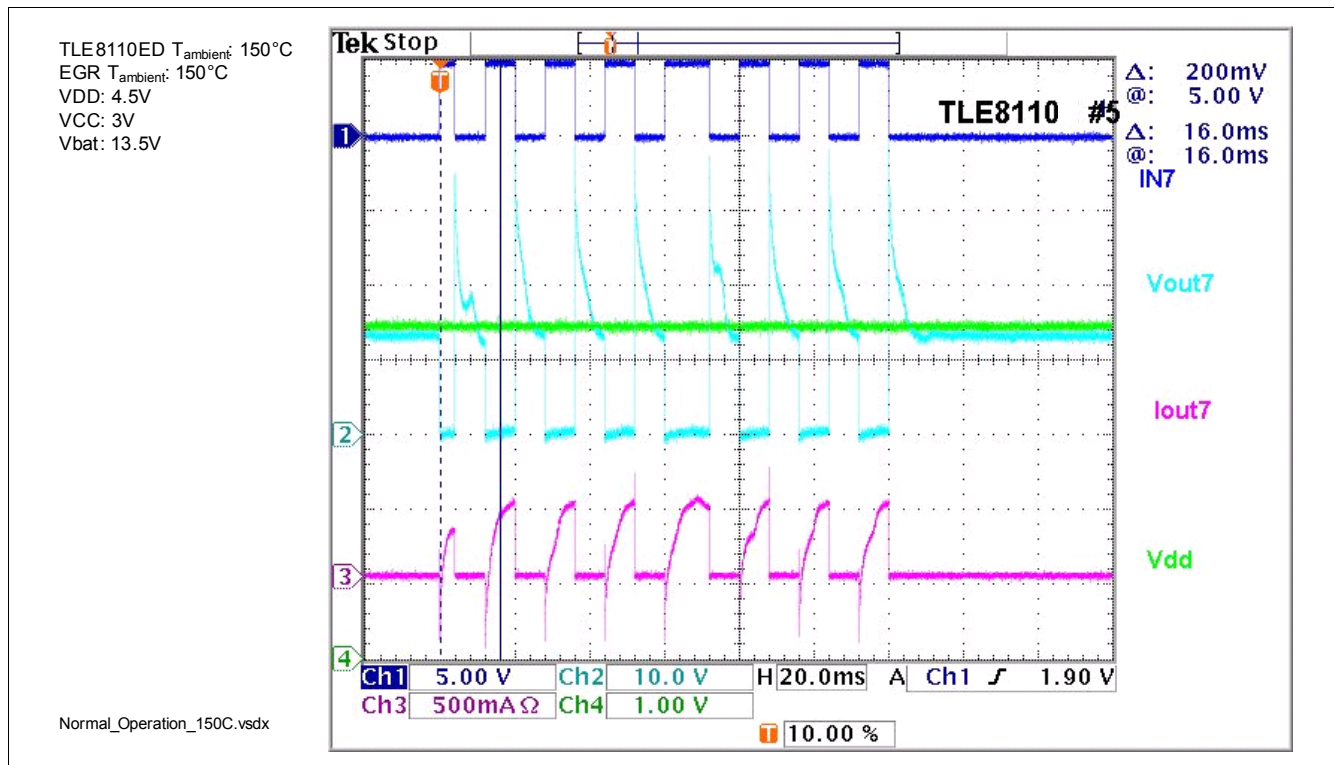

Figure 10 Normal operation mode at low  $V_{CC}$  and  $V_{DD}$  ( $T = 150^{\circ}\text{C}$ ,  $V_{\text{Bat}} = 13.5\text{ V}$ )

### 2.1.4 Summary

The executed tests show no diagnosis failure with the EGR stepper motor. There is no need for additional device settings.

## 2.2 Stopping the stepper motor

As soon as the control sequence stops the TLE8110ED no current flows through the coils. After switching off all channels, low or negative voltage at the output is caused by demagnetization and magnetic coupling.

### 2.2.1 Circuit

The following figure shows the connections between  $\mu\text{Controller}$ , TLE8110ED and the stepper motor. The signals marked in red in this figure are plotted in [Figure 12](#) and [Figure 13](#) (OUT 7, OUT 8,  $I_{\text{out}7}$  and  $I_{\text{out}8}$ ).

TLE8110ED behavior driving a unipolar EGR stepper motor

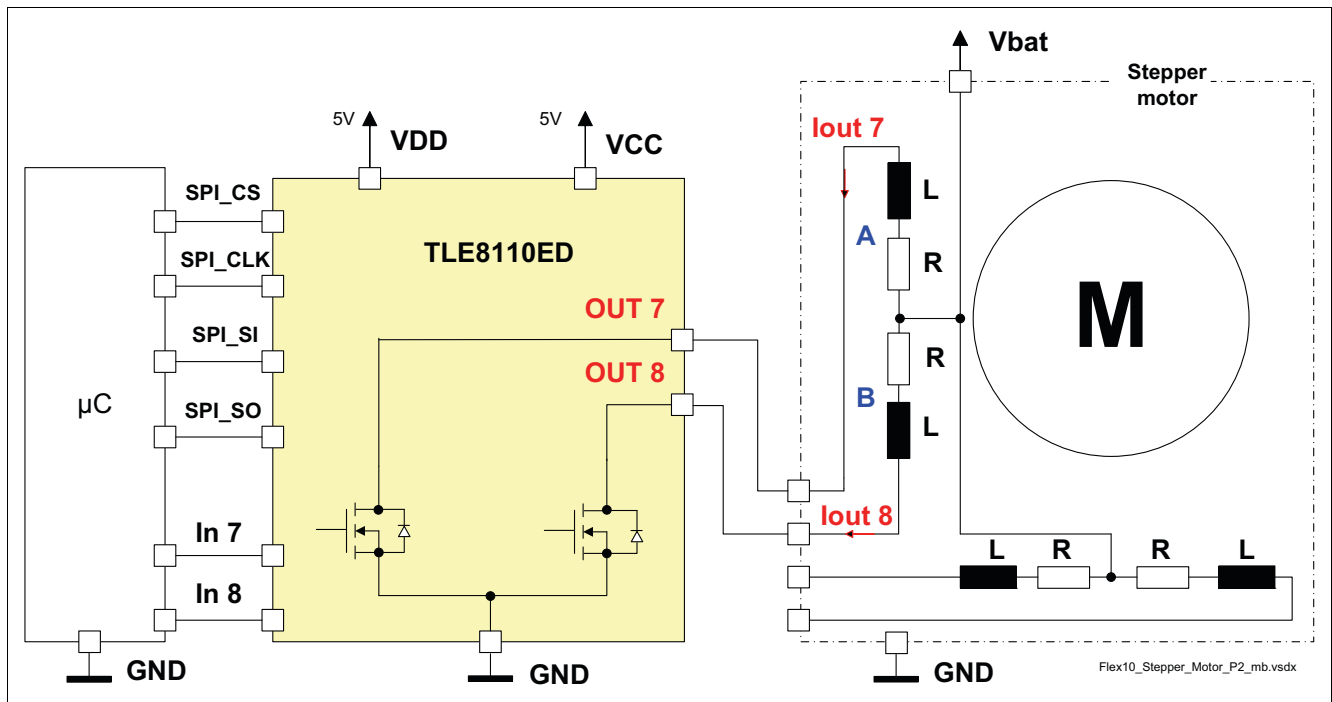

Figure 11 TLE8110ED with stopper motor and µC

### 2.2.2 Diagnosis

When the motor is stopped (stopping the current flow through all coils) a diagnosis entry: 00 (Short to Ground in OFF-Mode) will be stored in the diagnosis register of the TLE8110ED.

The unwanted diagnosis entry can be avoided by setting the diagnosis blind time to 2.5 ms.

### 2.2.3 Analysis

To analyze the unwanted behavior one coil of the motor is set to active for 10 ms. We choose this time to be sure that the coil is driven to saturation. The same time is used for normal operation.

If the TLE8110ED diagnosis blind time is set to default mode and the motor is stopped then there is a diagnosis entry set for “Short to Ground in OFF-Mode”. The default value for “Diagnosis-Blind-Time” is typically 150 µs.

Please note if the diagnosis blind time is set to 2.5 ms then no unwanted error will be stored into the diagnosis register.

Now have a look at **Figure 12**. In **Figure 11** we see that the coil connected to “Out 7” is called coil “A”. The coil connected to “Out 8” is called coil “B”. In this figure we can see that the output voltage for channel 8 is below the open load threshold for about 0.8 ms.

In this case a diagnosis blind time of 2.5 ms is enough to avoid an unwanted diagnosis entry.

So we see that we have to use the diagnosis blind time functionality to avoid unwanted diagnosis entries. In this case the setting for the blind time with typical 2.5 ms should be enough, but we will see in the next chapters that some applications needs a longer blind time for debouncing.

TLE8110ED behavior driving a unipolar EGR stepper motor

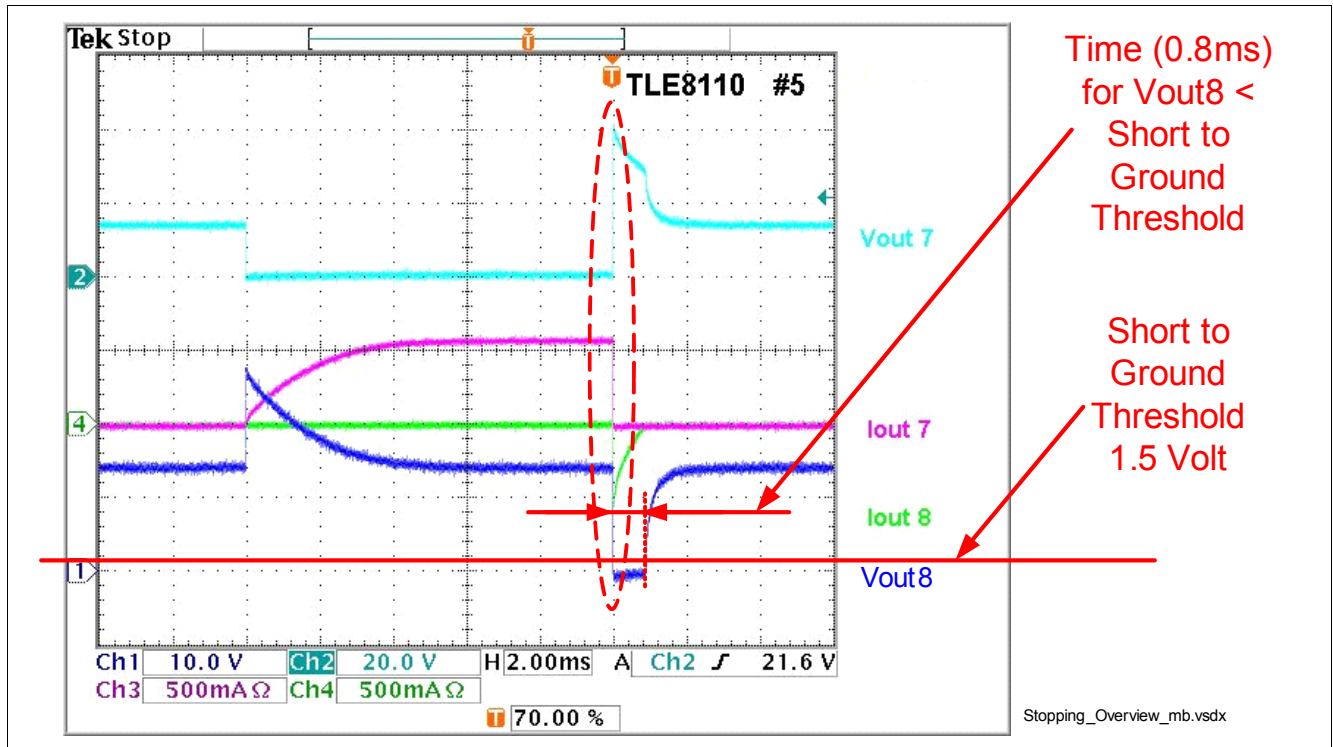

Figure 12 Stopping current flow through the stepper coils

In **Figure 13** we can see that the peak of the reverse current is in the range of 600 mA. So we can not use the RCP functionality because it's out of range as described in **Chapter 1.4**. In **Figure 14** we see the typical current for the outputs 7 to 10 for RCP functionality.

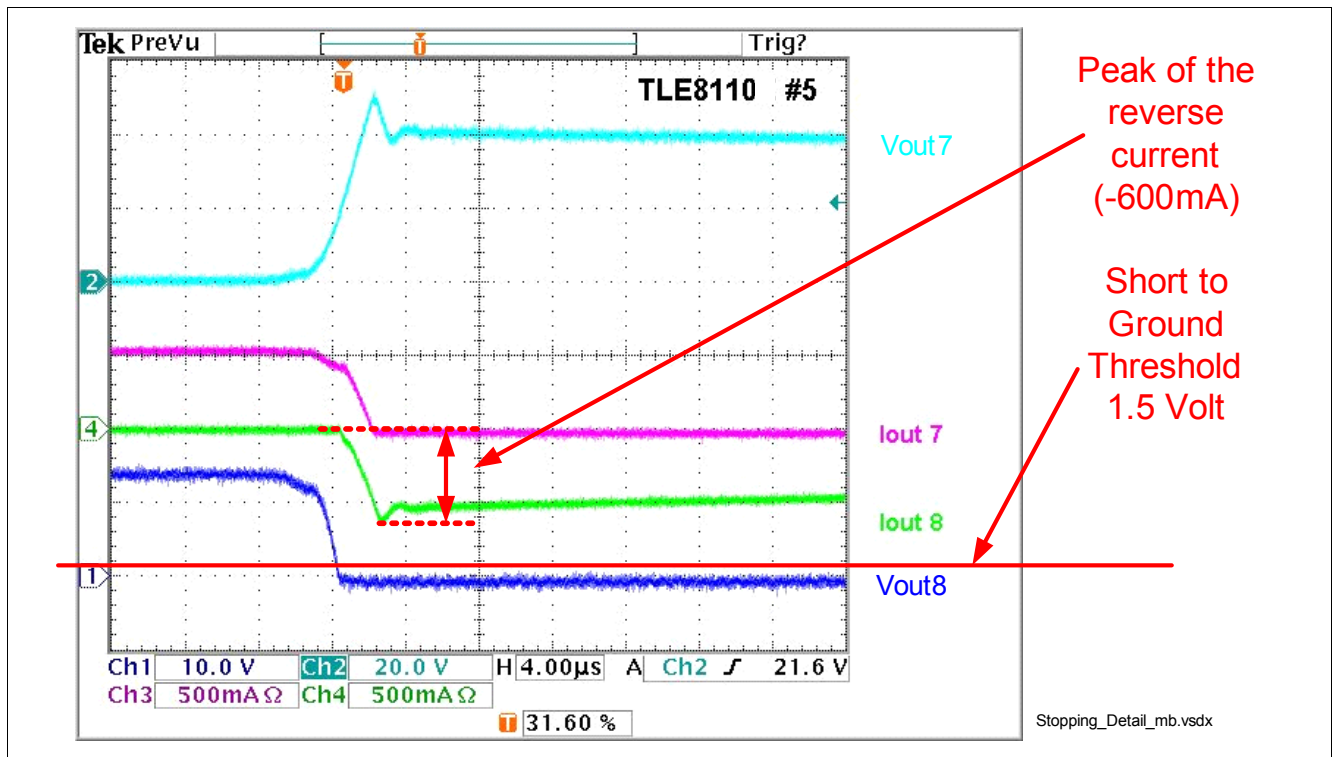

Figure 13 Detail of the previous figure

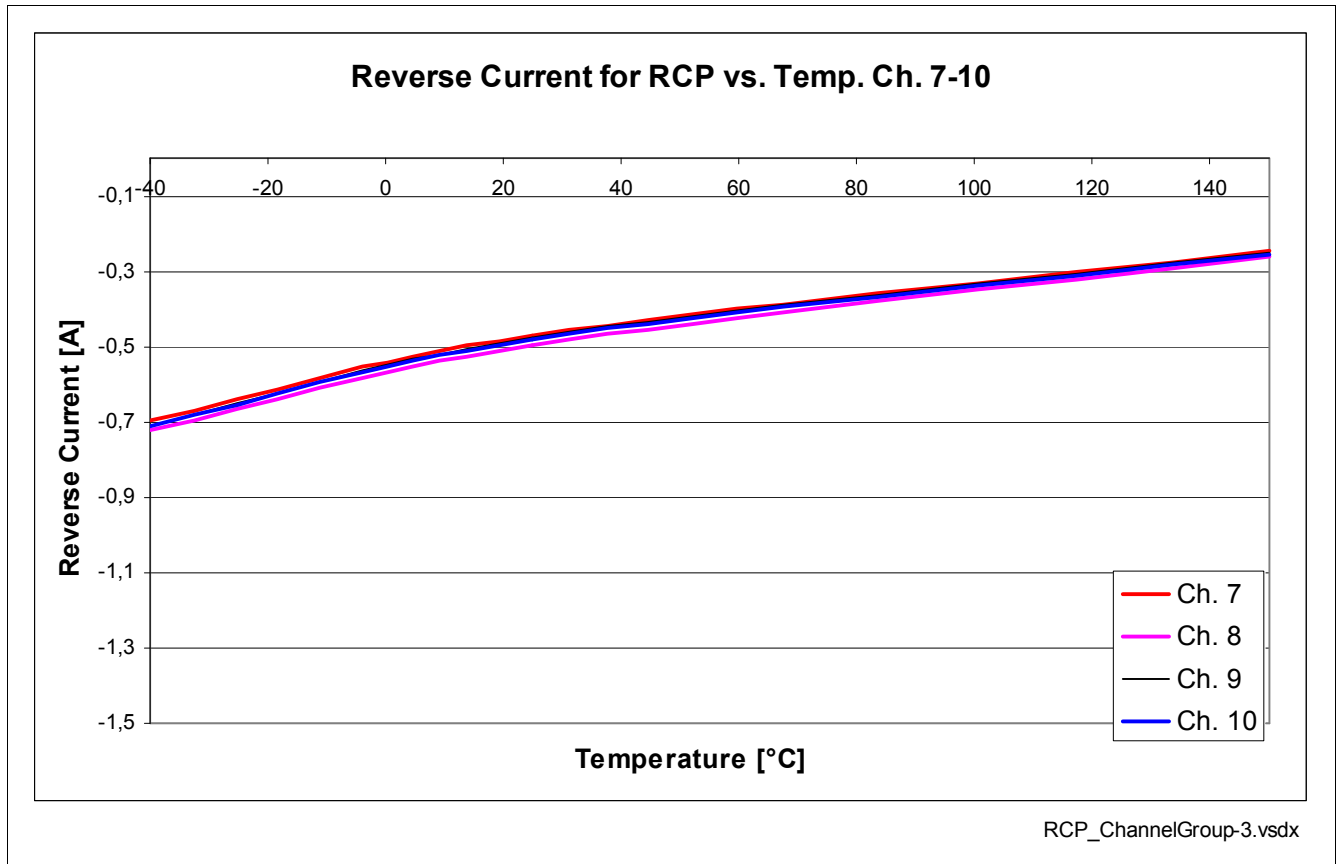

Figure 14 RCP current for channels 7 to 10

Coil “A” and coil “B” are magnetic linked. In principle both pairs of coils present a transformer with the translation 1:1. The strongly decreasing magnetic field induces a voltage into coil “B” when current flow through coil “A” is stopped. Because of this induced voltage a reverse current flows through coil “B” about 0.8 ms and the output voltage for channel 8 gets below the threshold for short to ground detection. Because of this there is the diagnosis entry “Short to Ground in OFF-Mode” for channel 8. There is no diagnosis entry when the diagnosis blind time from the TLE8110ED is set to 2.5 ms: “The diagnosis-logic is now ignoring potential register entries for typically 2.5 ms.” As long as the reverse current during remains < typically 2.5 ms, no unwanted entry in the diagnosis register appears. During the normal operating mode there are no diagnosis entries because when an output changes the state from “ON” to “OFF” then the neighbor output changes the state from “OFF” to “ON” and the “Short to Ground” diagnosis is an “OFF-State” diagnosis. [Figure 6](#) shows the control sequence for the stepper motor.

### 2.2.4 Summary

The performed tests show no unwanted diagnosis failure with the unipolar EGR stepper motor when the diagnosis blind time is set to 2.5 ms. The diagnosis is now debounced for typically 2.5 ms. As long as the reverse current duration remains < typ. 2.5 ms, no unwanted entry in the diagnosis register appears.

Driving an EGR stepper motor at battery voltages below 8 V

### 3 Driving an EGR stepper motor at battery voltages below 8 V

The stepper motor is driven with 6 V power supply on the outputs. A  $\mu$ Controller is controlling the TLE8110ED. The control sequence is shown in Figure 6. As an additional challenge we disconnect after some steps the Phase-C of the stepper motor from the output of the TLE8110ED (output 9). Please have a look at Figure 15.

#### 3.1 Circuit

The figure below shows the circuit with the  $\mu$ Controller, the TLE8110ED and the EGR-Valve with the disconnected (opened) Phase-C.

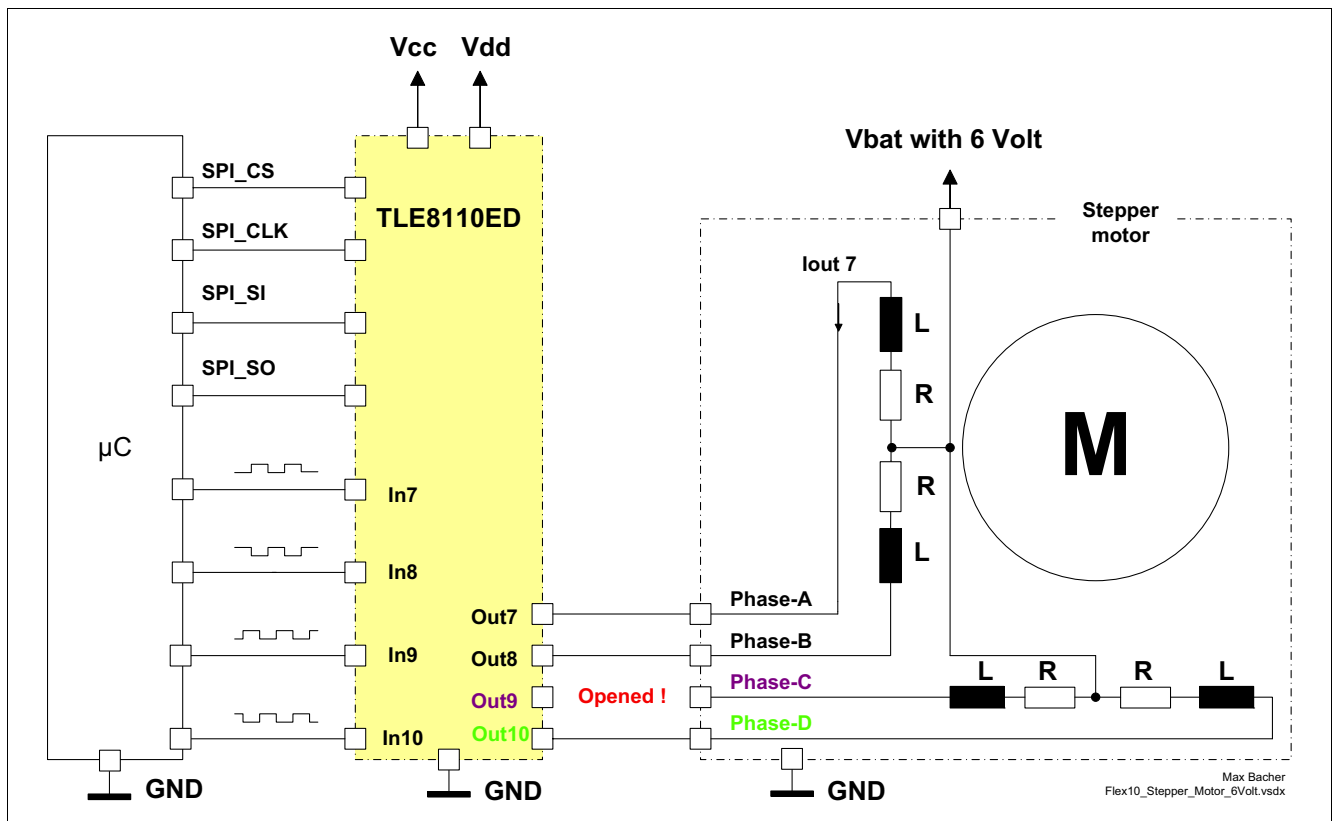

Figure 15 Circuit with the  $\mu$ Controller, the TLE8110ED and the EGR-valve with the disconnected (opened) phase-C

#### 3.2 Diagnosis

The diagnosis system recognizes the open output and reacts with an “open load” entry for the output 9 of the TLE8110ED which is disconnected from the Phase-C of the stepper motor. After some steps the diagnostic system executes also an “open load” entry for the output 10 of the TLE8110ED which is still connected to Phase-D of the stepper motor. This additional diagnosis entry is unwanted. This behavior of the stepper motor is only seen when  $V_{bat}$  is below 8 V. This behavior is a weakness of the stepper motor which loses steps when  $V_{bat}$  is below 8 V and a phase is disconnected.

#### 3.3 Analysis

The figure below shows the channels 9 and 10 of the TLE8110ED when the stepper motor is driven with 6 V power supply and all channels are connected. The red line in this figure shows the threshold voltage of the open load detection for the channel 10. This threshold voltage should be in the range from 2.00 V to 3.20 V. As typical value we measured about 2.68 V.

Driving an EGR stepper motor at battery voltages below 8 V

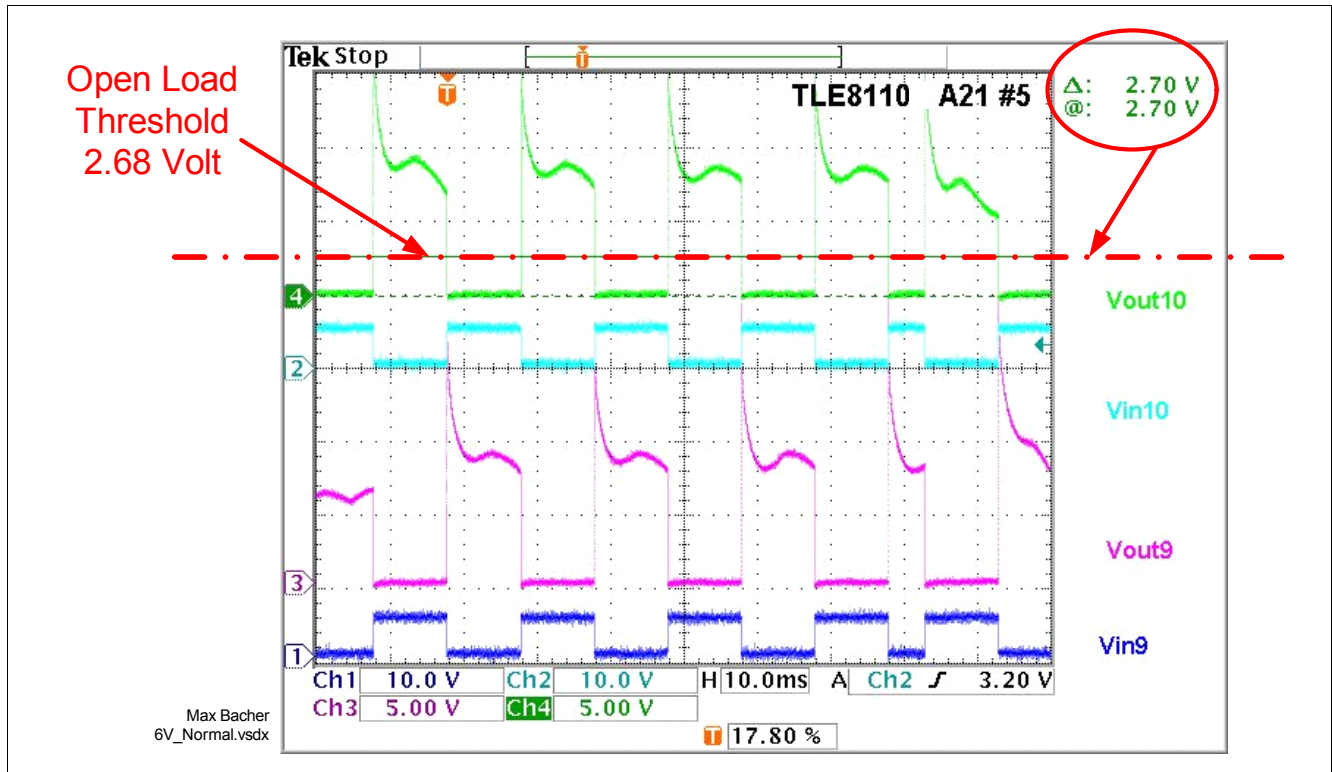

Figure 16 Stepper motor with 6 V power supply

Figure 17 is from the characterization for the open load threshold of channel 10 for different temperatures and different voltages for  $V_{DDs}$  and  $V_{CCs}$ . Here we can see that this value is well centered in the allowed range and we can also see that this threshold is stable over temperature and variation of  $V_{DD}$  and  $V_{CC}$ . Out from the characterization we see a threshold about 2.68 V.

Note: The minimum and maximum thresholds (LSL and USL) in Figure 17 are not the limits from the data sheet. Please have a look at the data sheet to get the thresholds.

Driving an EGR stepper motor at battery voltages below 8 V

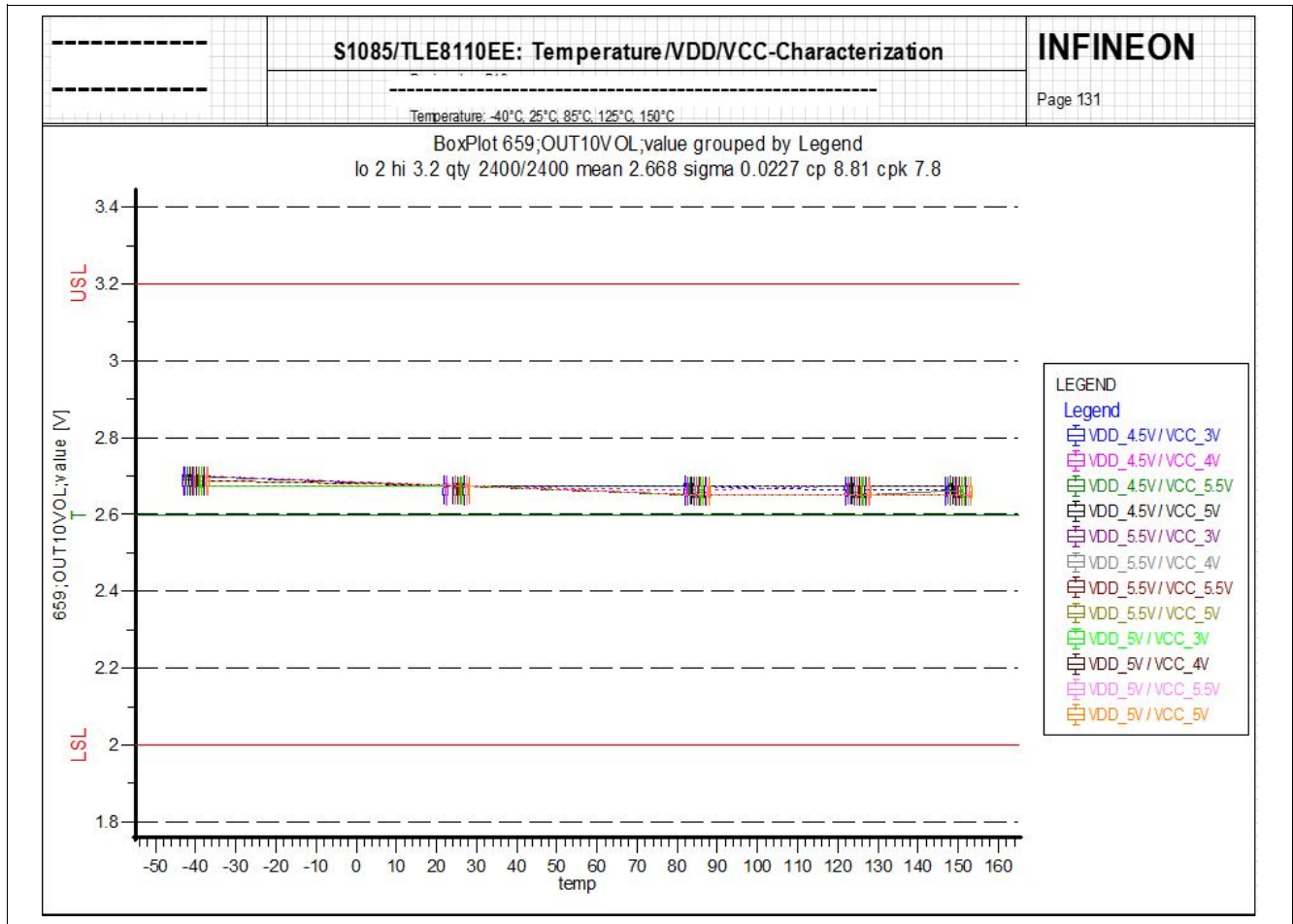

Figure 17 Characterization for open load threshold

In **Figure 18** we see that the voltage on output 10 is below the open load threshold. The open load threshold is marked with a red line and is about 2.68 V. This behavior is seen when we drive the stepper motor with  $V_{bat}$  below 8 V and disconnecting the phase-C of the stepper motor from the output 9 of the TLE8110ED. In this case we have 6 V for  $V_{bat}$ .

*Note: On the output of channel 9 is always a LED connected. This is a special behavior of the lab board to see the state of the output. Because of this we see on the output of channel 9 always a voltage when the channel is switched off- even when the wire of the stepper motor is disconnected.*



Driving an EGR stepper motor at battery voltages below 8 V

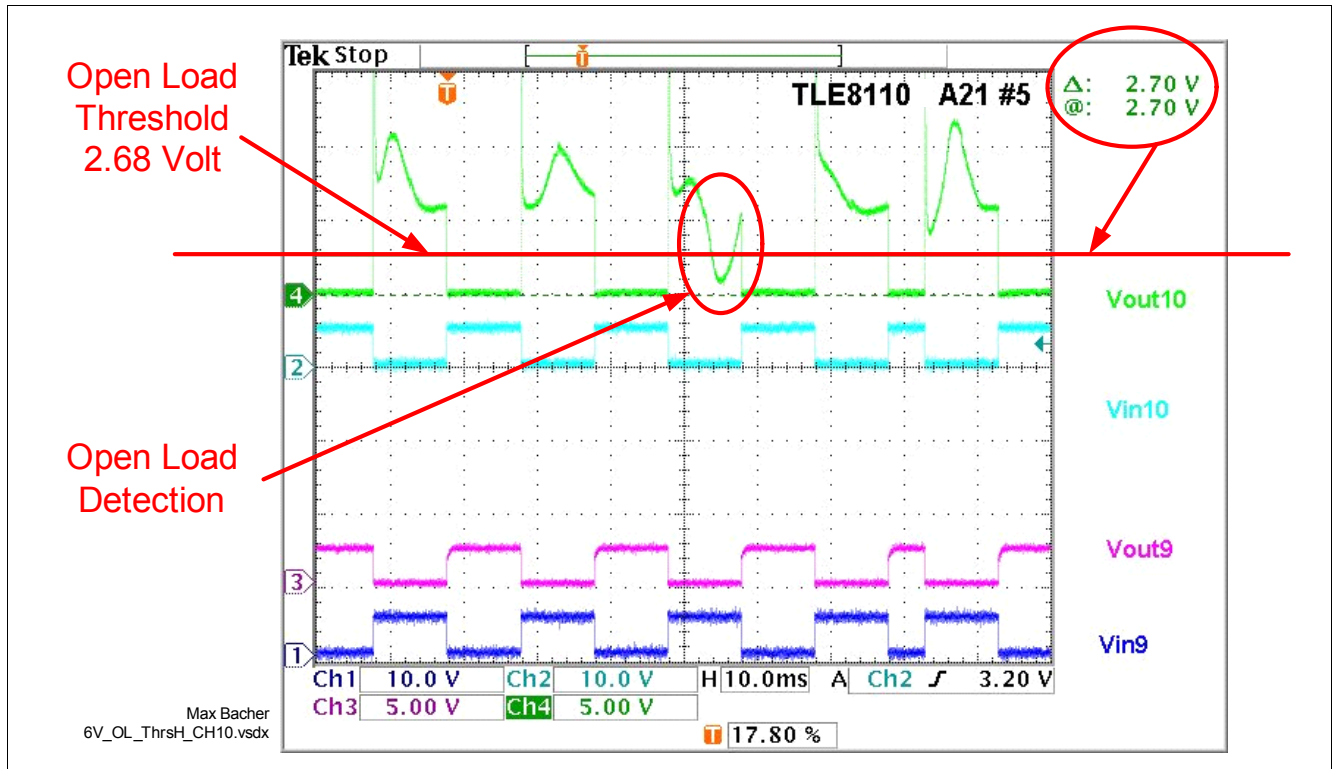

Figure 18 Stepper motor with 6 V power supply and disconnected phase-D

Figure 19 highlights the open load detection for output 10 in red. Output 10 is connected with the phase-D of the stepper motor. When there are no special device settings for a longer blind time we have an unwanted open load diagnosis entry for channel 10. In the Figure 20 we discuss the behavior in detail. The blue line in these figures is an external trigger signal to catch the right moment.

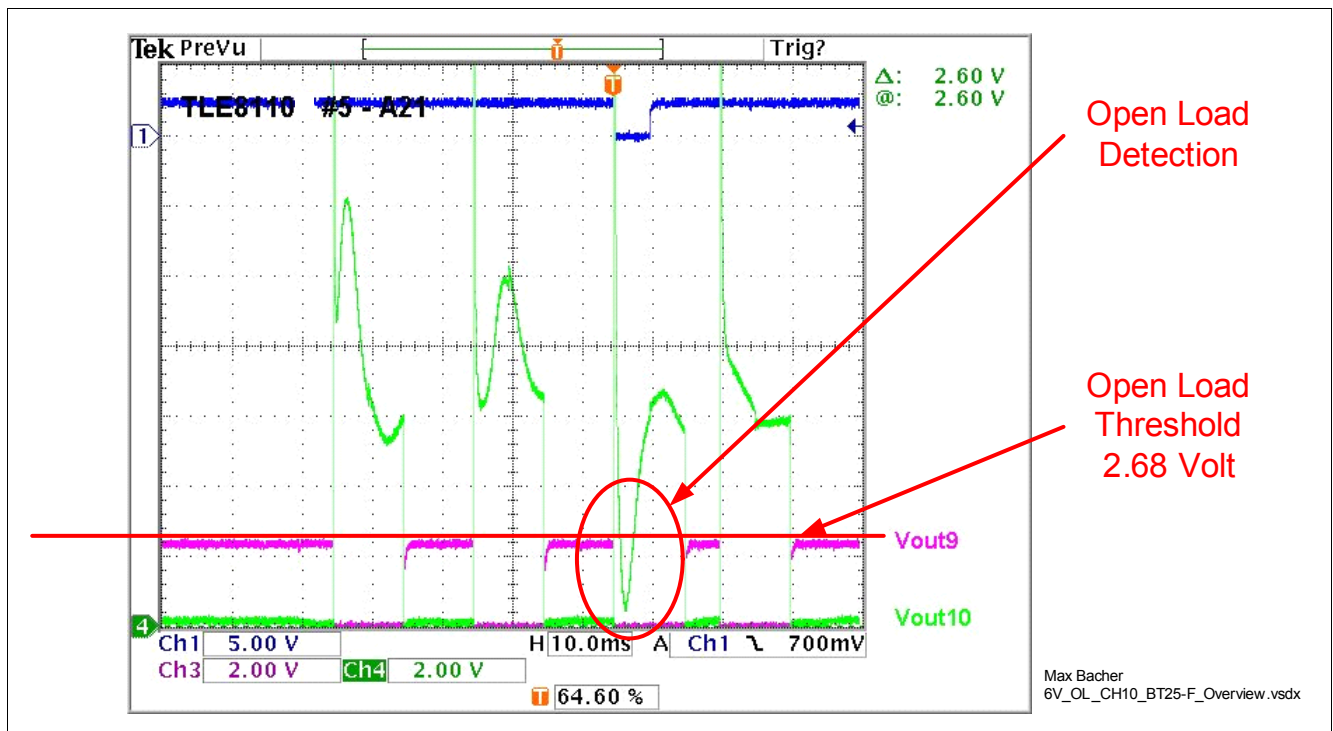

Figure 19 Overview of the open load detection for channel 10

Driving an EGR stepper motor at battery voltages below 8 V

Figure 20 shows the behavior from Figure 19 with a higher time resolution - 1 ms against 10 ms in the previous figure. The green line is the voltage on channel 10. We see that the voltage is for a longer time than the DBT1 (Diagnosis Blind Time 1) below the open load threshold.

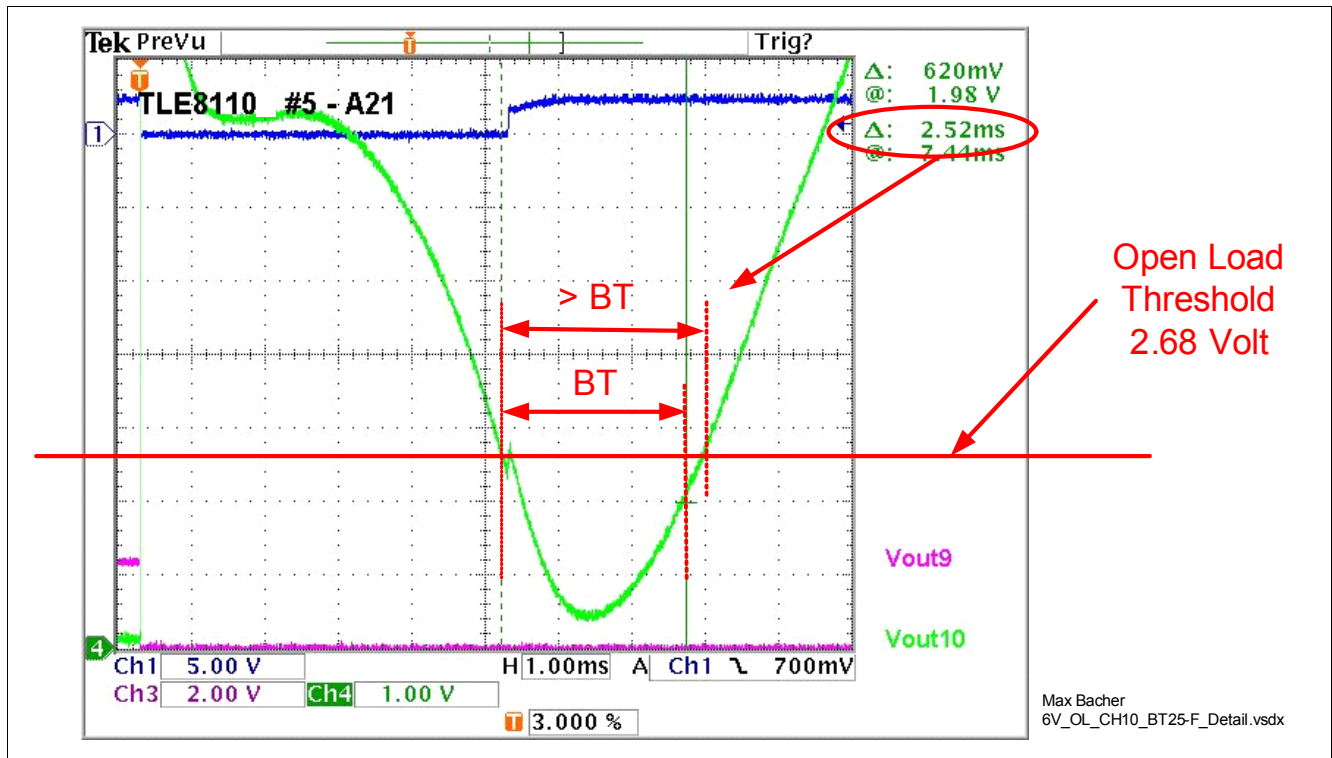

Figure 20 Detail of the open load detection for channel 10

DBT1 has a typical value of 2.5 ms and is in the range of 1.75 ms to 3.25 ms. Without setting the diagnosis blind time to a higher value we have an unwanted open load diagnosis entry for this special case. But we can also see that this diagnosis entry is no failure of the TLE8110ED. It's the behavior of the stepper motor which is not able to drive without losing steps when  $V_{bat}$  is 6 V and disconnecting one phase.

The value of the voltage measured on the output is the superposition of:

- Voltage caused by the resistive load.
- Voltage induced by the inductive load.
- Voltage caused by the transformer principle. In principle both pairs of coils present a transformer with the ratio 1:1.
- Voltage induced by the rotating rotor with its magnetic field.

The voltage induced by the rotating magnetic field could be measured in an indirect way:

- The measured voltage on the output is the superposition of all voltages.
- There is no rotating magnetic field when the stepper motor is disassembled (the rotor is removed from the stepper motor, so it could not rotate and generate the rotating magnetic field).
- In this case there is no contribution to the superposition of the voltages.
- Now the effect from the rotating magnetic field could be seen in an indirect way.

Figure 21 shows the output voltage form the channels 7 to 10 with the assembled and also with the disassembled stepper motor. On this channels are the coils from the stepper motor connected.  $V_{bat}$  for the stepper motor is 6 V.

Driving an EGR stepper motor at battery voltages below 8 V

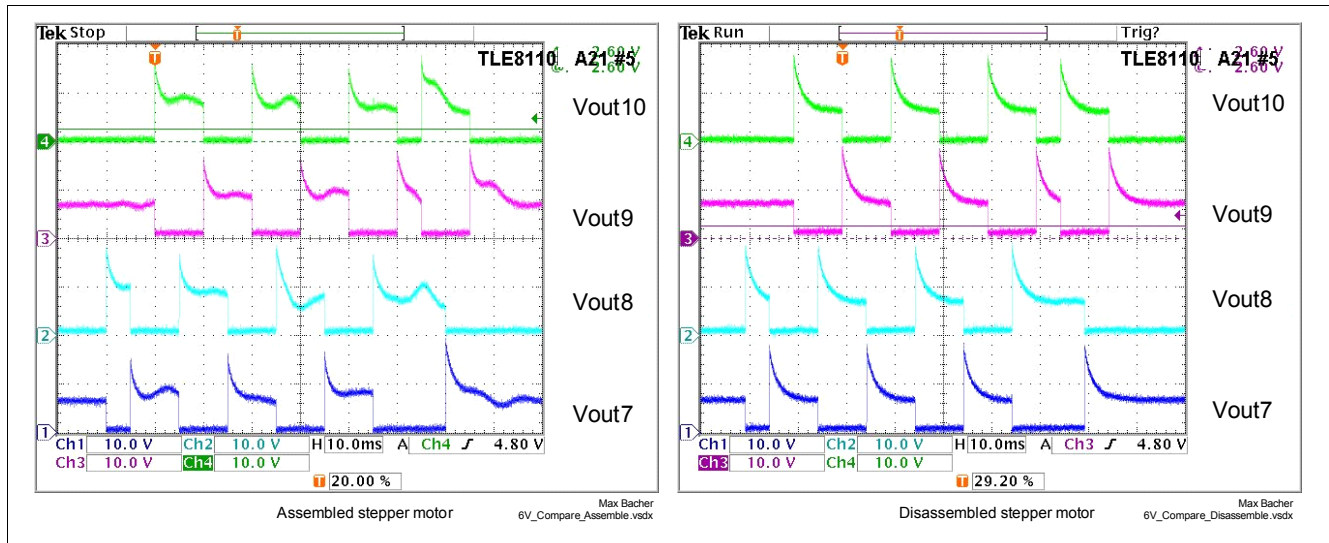

Figure 21 Output voltage for the assembled and disassembled stepper motor

Figure 22 shows the output voltage from the channels 7 to 10 with the assembled and also with the disassembled stepper motor. Channel 9 is not connected to the phase-C of the stepper motor. All other channels are connected to the stepper motor.  $V_{bat}$  for the stepper motor is 6 V.

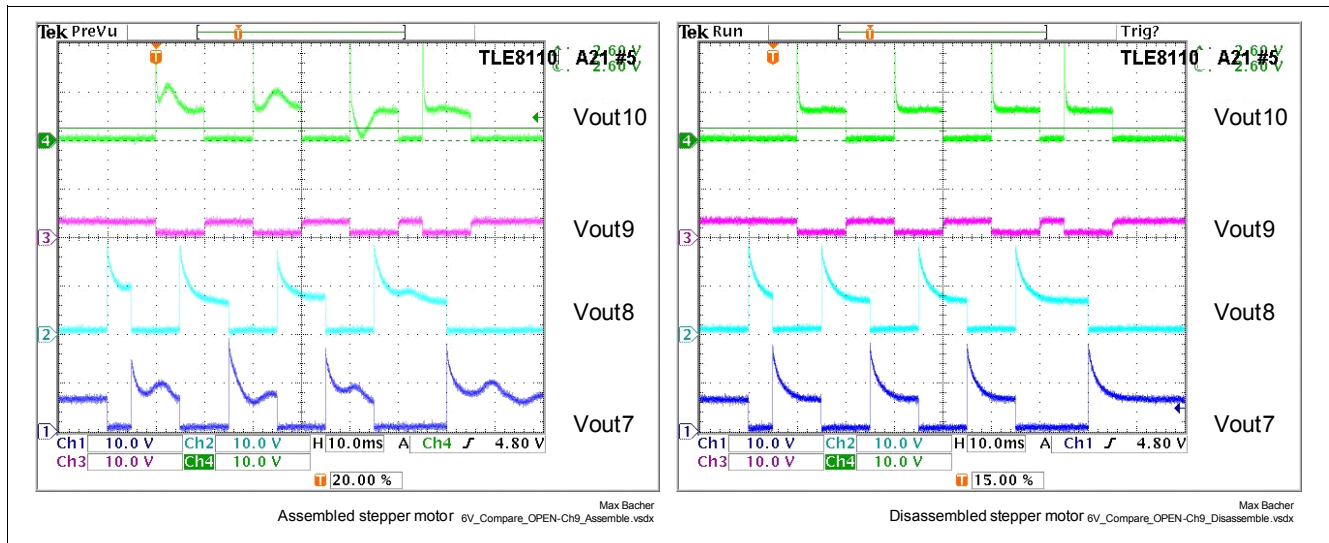

Figure 22 Output voltage for the assembled and disassembled stepper motor with disconnected phase-C

There are three effects because of the rotating magnetic field:

- The amount of the induced voltage depends on the rotating speed (the absolute value).
- There are two possibilities for the algebraic sign of the induced voltage: It could depend on the rotor rotation direction or it's also possible that the magnetic field from the rotor is on the wrong position (one phase displaced).
- The time stamp where the induced voltage appears depends on the position of the rotor (phase shifting)

Figure 23 shows the influence of the speed from the magnetic field. The rotating of the magnetic field from the rotor induced a voltage into the coils. If the rotating speed of the magnetic field increases, the absolute value of the voltages also increases. If the rotating speed of magnetic field decreases, the absolute value of the voltage also decreases.

Driving an EGR stepper motor at battery voltages below 8 V

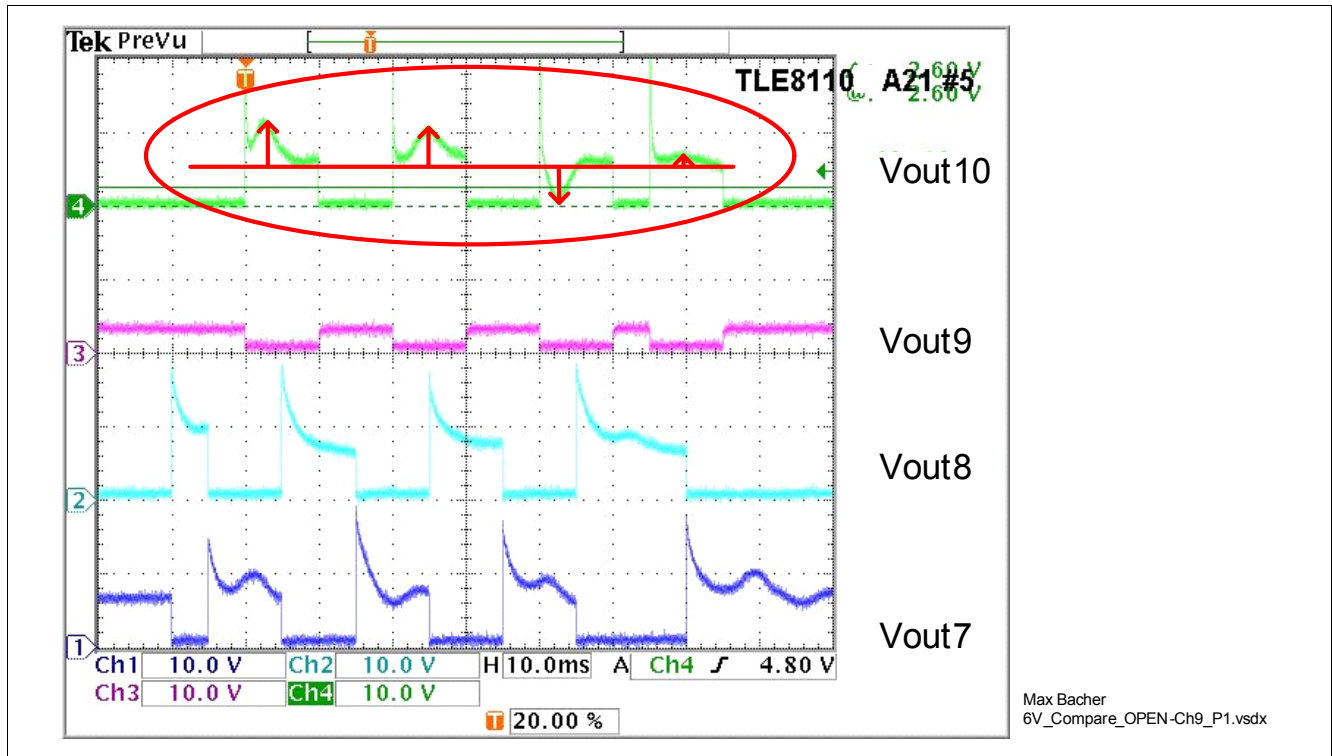

Figure 23 Influence of the speed from the magnetic field to the output voltages

Figure 24 shows the influence of the induced voltage from the magnetic field. There are two possibilities for the algebraic sign: It could depend on the rotor rotation direction or it's also possible that the magnetic field from the rotor is on the wrong position (one phase displaced).

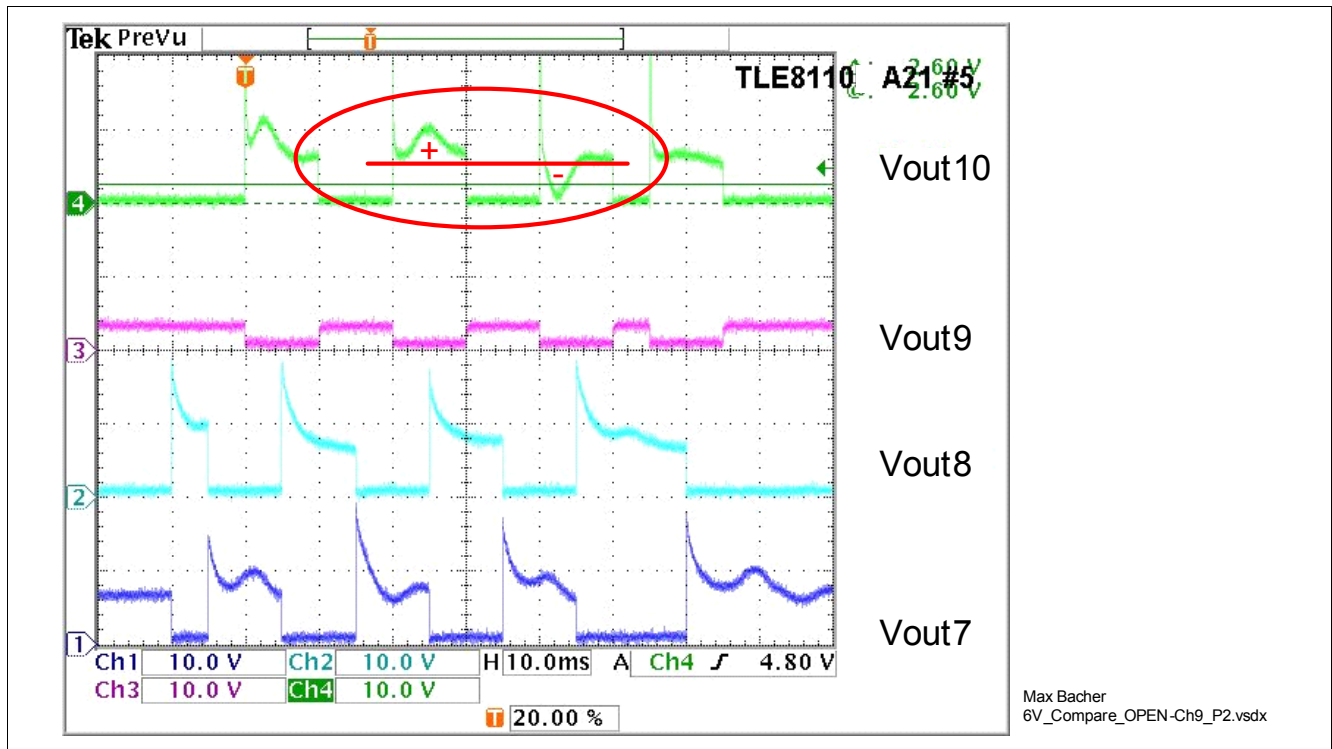

Figure 24 Influence of the acceleration from the magnetic field on the output voltages

Driving an EGR stepper motor at battery voltages below 8 V

Figure 25 shows the influence of the time stamp from the induced voltage. The time where the induced voltage appears depends on the position of the rotor (phase shifting). The position of the rotor is a little different between the steps. This means that the position of the rotor is not always on the same position when the output is turned on.

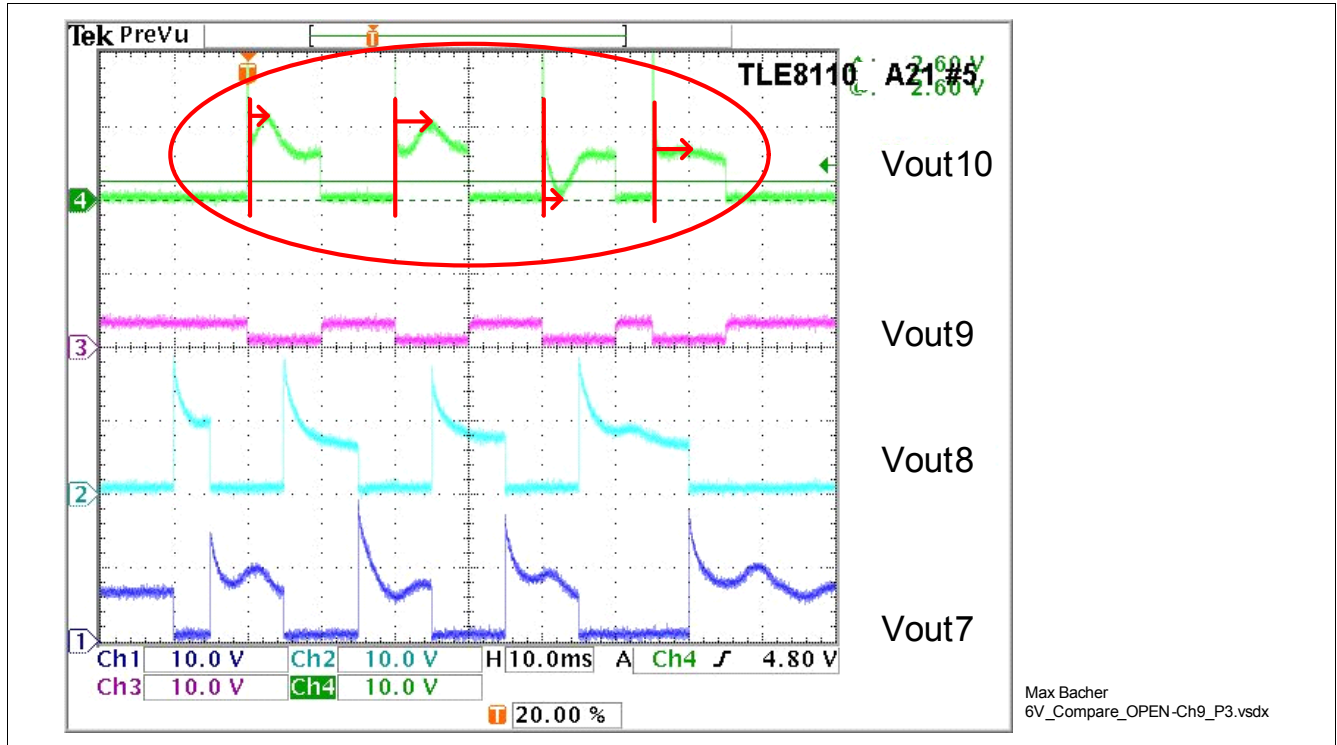

Figure 25 Influence of the induced voltage regarding time

### 3.4 Summary

The operation mode of the stepper motor is with  $V_{bat}$  6 V near the limit (maybe losing steps). In 6 V operations mode the stepper motor loses steps when disconnecting an output. The stepper motor does not work properly now. This losing of steps occurs in a change of the speed and the phase from the rotor. With the rotor also the magnetic field (from the rotors permanent magnets) is changed very fast. So it's possible that the magnetic field is some times on the wrong position. And so the voltage on the neighbor channel could be below the threshold of the OFF-mode diagnosis detection.

*Note: The behavior of losing steps described above is non-linear and has a random behavior. Therefore, the classical mathematical terms for the neighboring channels in the presence of the described behavior could not be provided.*

## Conclusion

### 4 Conclusion

The Flex TLE8110ED is able to drive a unipolar stepper motor in a large number of operation modes. With the special feature of the diagnosis blind time it's also possible to drive the stepper motor with a  $V_{bat}$  below 8 V and with a disconnected phase. With special feature the Flex TLE8110ED provides no unwanted diagnosis entries to the  $\mu$ Controller. So we can say: The Flex TLE8110ED is able to recognize the weakness of external devices and protects in this way the  $\mu$ Controller.

We recommend enabling the DBT and RCP functions for unipolar stepper motor applications. In normal operation (without an open connection or short circuit), the TLE8110ED diagnostics function properly when  $V_{bat}$  is greater than 6 V. An open circuit between the TLE8110ED and the stepper motor may cause a wrong diagnostic result when  $V_{bat}$  is less than 8 V (two open faults set instead of one).

## 5 Additional Information

### 5.1 Short product characteristics for the used stepper motor

**Table 2** shows the electrical connections for the unipolar stepper motor, and **Figure 26** shows the short product characteristics. Please note: “The stepper motor was not disassembled for these measurements”.

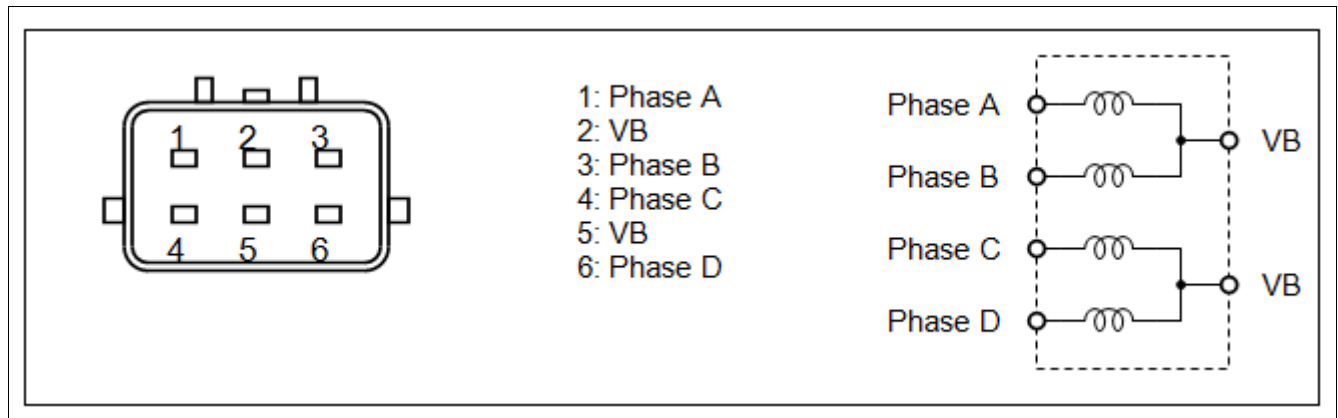

**Figure 26** Electrical connections of the stepper motor

**Table 2** Characteristics for stepper motor

Phase A-B	Phase A-VB	Phase B-VB		Phase C-D	Phase C-VB	Phase D-VB
L = 56.5 mH	L = 14 mH	L = 13.9 mH		L = 55.9 mH	L = 13.8 mH	L = 13.8 mH
R = 45 Ω	R = 22.5 Ω	R = 22.5 Ω		R = 44.9 Ω	R = 22.4 Ω	R = 22.5 Ω

## **6 Existing Application Notes**

- Existing Application Notes:
  - SPI interface and use in a daisy-chain bus configuration
  - Switching Inductive Loads
  - TLE8110ED Switching Inductive Loads and External Clamping
- For further information you may contact <http://www.infineon.com/>



**Revision History**

## **7 Revision History**

<b>Revision</b>	<b>Date</b>	<b>Changes</b>
0.1	2017-1-15	Initial release

#### Trademarks of Infineon Technologies AG

$\mu$ HVIC™,  $\mu$ IPM™,  $\mu$ PFC™, AU-ConvertIR™, AURIX™, C166™, CanPAK™, CIPOS™, CIPURSE™, CoolDP™, CoolGaN™, COOLIR™, CoolMOS™, CoolSET™, CoolSiC™, DAVE™, DI-POL™, DirectFET™, DrBlade™, EasyPIM™, EconoBRIDGE™, EconoDUAL™, EconoPACK™, EconoPIM™, EiceDRIVER™, eupec™, FCOS™, GaNpowIR™, HEXFET™, HITFET™, HybridPACK™, iMOTION™, IRAM™, ISOFACE™, IsoPACK™, LEDrivr™, LITIX™, MIPAQ™, ModSTACK™, my-d™, NovalithIC™, OPTIGA™, OptiMOS™, ORIGA™, PowIRaudio™, PowIRstage™, PrimePACK™, PrimeSTACK™, PROFET™, PRO-SIL™, RASIC™, REAL3™, SmartLEWIS™, SOLID FLASH™, SPOC™, StrongIRFET™, SupIRBuck™, TEMPFET™, TRENCHSTOP™, TriCore™, UHVIC™, XHP™, XMC™.

Trademarks updated November 2015

#### Other Trademarks

All referenced product or service names and trademarks are the property of their respective owners.

**Edition 2017-1-15**

**Published by**

**Infineon Technologies AG**

**81726 Munich, Germany**

**© 2017 Infineon Technologies AG.**

**All Rights Reserved.**

**Do you have a question about any aspect of this document?**

**Email: [erratum@infineon.com](mailto:erratum@infineon.com)**

**Document reference**

**Z8F56525712**

#### IMPORTANT NOTICE

The information contained in this application note is given as a hint for the implementation of the product only and shall in no event be regarded as a description or warranty of a certain functionality, condition or quality of the product. Before implementation of the product, the recipient of this application note must verify any function and other technical information given herein in the real application. Infineon Technologies hereby disclaims any and all warranties and liabilities of any kind (including without limitation warranties of non-infringement of intellectual property rights of any third party) with respect to any and all information given in this application note.

The data contained in this document is exclusively intended for technically trained staff. It is the responsibility of customer's technical departments to evaluate the suitability of the product for the intended application and the completeness of the product information given in this document with respect to such application.

For further information on technology, delivery terms and conditions and prices, please contact the nearest Infineon Technologies Office ([www.infineon.com](http://www.infineon.com)).

#### WARNINGS

Due to technical requirements products may contain dangerous substances. For information on the types in question please contact your nearest Infineon Technologies office.

Except as otherwise explicitly approved by Infineon Technologies in a written document signed by authorized representatives of Infineon Technologies, Infineon Technologies' products may not be used in any applications where a failure of the product or any consequences of the use thereof can reasonably be expected to result in personal injury.