

1 Watt Step up DC-DC White LED Driver ME2106 Series

Description:

ME2106 Series is a PFM Step-up DC/DC driver IC with invariant current, design for LED applications. Though the external resistance, output current reach 0mA~500mA.

A low ripple, high efficiency step-up DC/DC converter can be constructed of ME2106xx with only three external components. Also available is a CE (chip enable) function that reduce power consumption.

Features:

- Low start voltage: 0.8V (at Iout=1mA)
- Output Current range: 0~ 500mA
- Output Current accuracy: $\pm 10\%$
- Only inductors, capacitors, Schottky diodes, resistors and so few external components
- High Efficiency: 82%(Type)
- PACKAGE: SOT-23-5, SOT-89-5

Selection Guide:

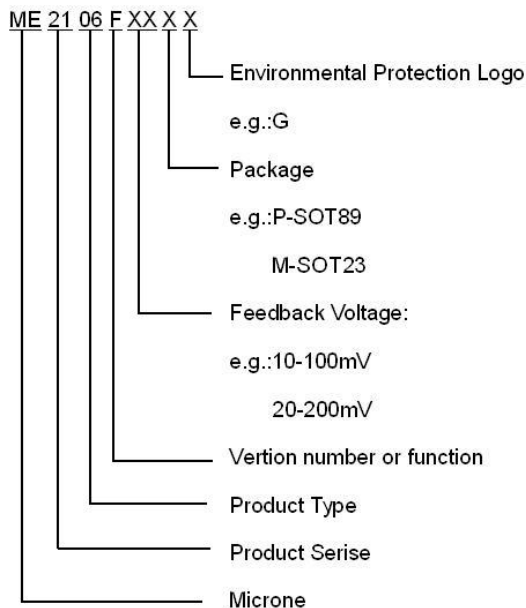

Applications:

- Power source for high-power LED
- Power source for invariant current

Pin configuration :

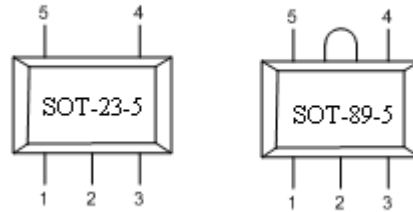

Pin Assignment:

ME2106Fxx

PIN Number		PIN NAME	FUNCTION
SOT-23-5	SOT-89-5		
1	3	CE	Chip enable
2	2	Vout	Output voltage monitor, IC internal power supply
3	1	FB	Feedback
4	5	GND	Ground
5	4	Lx	Switch

Block Diagram:

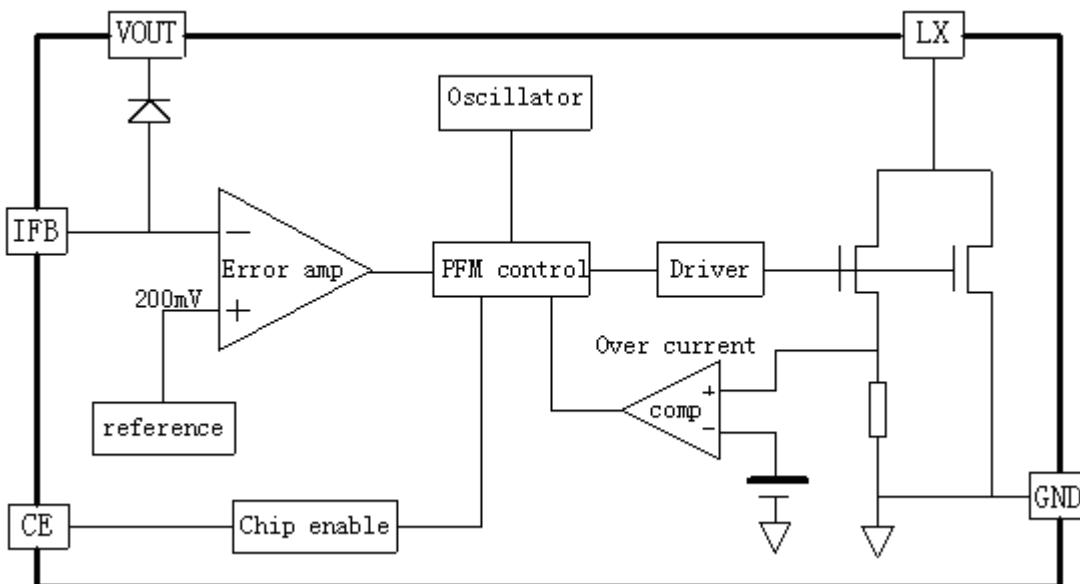

Absolute Maximum Ratings:

PARAMETER		SYMBAL	RATINGS	UNITS
V _{IN} Input Voltage		V _{IN}	0.3~6.5	V
Lx Pin voltage		V _{LX}	0.3~Vout+0.3	V
CE Pin voltage		V _{CE}	0.3~Vout+0.3	V
IFB output voltage		V _{IFB}	0.3~Vout+0.3	V
Lx Pin current		I _{LX}	1.5	mA
Continuous Total Power Dissipation	SOT-23-5	Pd	300	mW
	SOT-89-5	Pd	500	mW
Maximum Operating Ambient Temperature		T _{max}	150	°C
Operating Ambient Temperature		T _{Opr}	-20~+85	°C
Storage Temperature		T _{stg}	-40~+125	°C
Soldering temperature and time		T _{solder}	260°C, 10s	

Recommend work conditions:

PARAMETER	MIN	RECOMMEND	MAX	UNITS
Input voltage	0.8		Vout	V
Inductance	10	15	100	μH
Input inductance	0	≥22		μF
output inductance	47	100	220	μF
Operating Ambient Temperature	-20		85	°C

Electrical Characteristics:

ME2106F (Measuring conditions: $V_{IN}=2.5V$, $V_{CE}=V_{OUT}=3.3V$, $R=33\Omega$, $T_A=25^\circ C$. Unless otherwise specified)

SYMBOL	PARAMETER	CONDITIONS	MIN	TYP	MAX	UNITS
V_{OUT}	feedback Voltage	$I_{OUT}=100mA$	180	200	220	mV
V_{start}	Starup Voltage	$I_{OUT}=1mA$, $V_{IN}: 0 \rightarrow 2V$		0.8	0.9	V
V_{hold}	holding Voltage	$I_{OUT}=1mA$, $V_{IN}: 2 \rightarrow 0V$	0.6	0.7		V
I_{DD2}	Supply Current	$V_{CE}=V_{IFB}=V_{OUT}=3.3V$			50	μA
I_{LXleak}	Lx Leakage Current	$V_{CE}=V_{LX}=V_{OUT}=V_{IFB}=3.3V$			1	μA
F_{osc}	Oscillation Frequency	$V_{IFB}=0$		300		kHz
Maxdty	Duty Ratio	On(V_{LX} "L")side	77	79	82	%
η	Efficiency	$I_{OUT}=250mA$		82		%
V_{CEH}	CE is "H",input voltage	$V_{CE}: 0 \rightarrow 2V$ (up to work slowly with the chip)	0.6			V
V_{CEL}	CE is "L",input voltage	$V_{CE}: 2V \rightarrow 0$ (down to work off slowly with the chip)			0.4	V

Notes:

- 1、Diode: Schottky diode (forward voltage drop : 0.3V, 0.3A), such as IN5817 or 1N5819
- 2、Inductor: 15 μH ($R < 0.5 \Omega$)
- 3、Capacitor: 100 μF (Tantalum type)
- 4、 V_{IFB} (SET) is feedback voltage of the chip set up , is the first parameter of the table ,such as 200mV 。

Typical Applications:

Application of constant current output

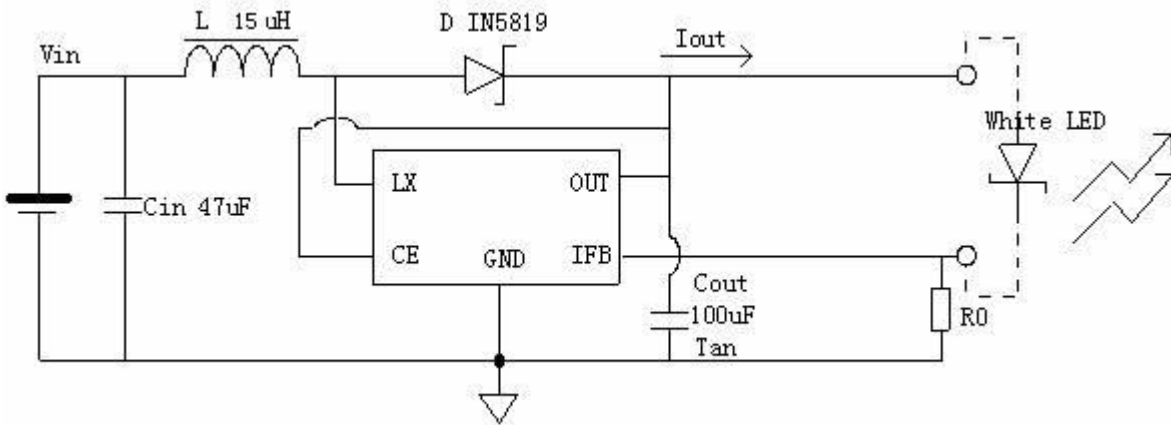

(A) Drive one white light LED with 1W

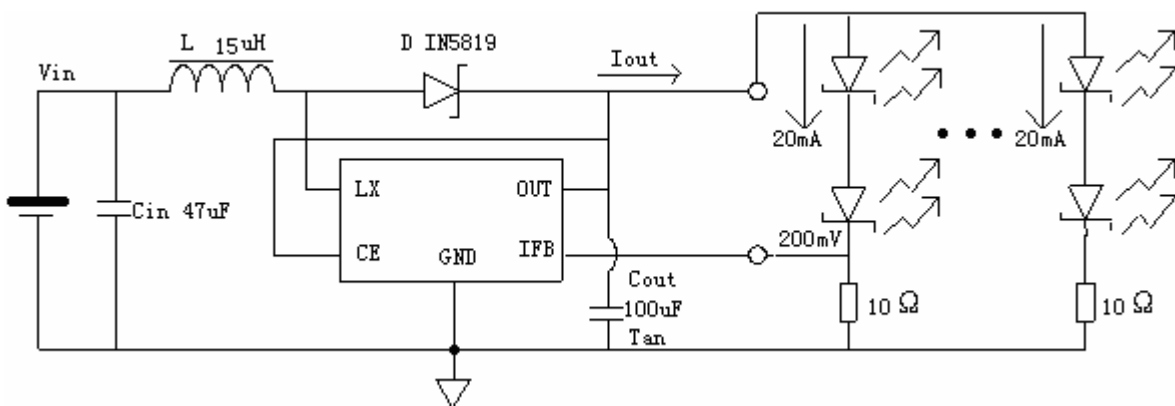

(B) Drive more serial two parallel white light LED with low power

Suggestions:

- You can increase the output capacitor properly for improve to the characteristic of the output invariant current (for example: 150uF or 200uF)。
- To avoid the feedback voltage excursion, please wear the ring with static electricity and the electric iron connect to ground when the soldering。

Operation:

ME2106 is a DC/DC step-up converter with voltage type , PFM control mode , output invariableness current. It has only three Peripheral components that is a inductor 、 a output capacitor、 a schottky diode and a resistor with set-up output current, that can afford to a invariant output current between 0 and 500mA .Rc set-up method: If the output current is Iout, that $Rc = \frac{V_{IFB}}{I_{out}}$ 。 For example, want to the current value of 100mA , select the chip of VIFB=200mV, that $Rc = 200mV / 100mA = 2\Omega$ 。

Selection of Peripheral Components and Application Notes

Sum up , inductor , schottky diode would be affect the switching efficiency , capacitor and inductor would be affect the output ripple. Choose such an inductor, capacitor, schottky diode that have high switching efficiency, low ripple, low noises.

Before discussion, define to $D \equiv \frac{V_{out} - V_{in}}{V_{out}}$ 。

First, selection of inductor

Make sure DC-DC can natural work firstly in the model of the minimum continuous current that is Lmin, $L_{min} \geq \frac{D(1-D)^2 R_L}{2f}$ 。

This formula deduce that ignoring the autoecious resistor and a diode with the forward voltage drop, but the actual value is still big. If the inductance less than Lmin, inductor will reach magnetic saturation, efficiency will greatly drop, and hardly output steady voltage.

Secondly , considering the current ripple of the inductor, ignoring the autoecious parameter in the mode of continuous current.

$$\Delta I = \frac{D \cdot V_{in}}{L_f} , \quad I_{max} = \frac{V_{in}}{(1-D)^2 R_L} + \frac{D V_{in}}{2 L_f} .$$

When “L” is too small, will lead to high current ripple of the inductor , and the maximum current of the inductor , schottky diode , power tube of the chip are excessive .

Thirdly, generally speaking, not considering efficiency , small inductor can drive load more then large inductor .But in the same load conditions , large inductor with the current ripple and the maximum current value are small. So the large inductor should be able to start up circuit in the low input voltage.

Use inductor with an inductance of 10μH or more ,it's ensure to normal work . If output port has load with output large current (for example: output current is more than 50mA), for improving to efficiency, suggest to use large inductor. At the same time, in the large load, the resistor is in series with the inductor that will affect the switching efficiency. Supposed , the resistor is rL, Rload, that the power consumption as follow:

$$\Delta \eta \approx \frac{r_L}{R_{load}(1-D)^2}$$

For example, input 1.5V, output 3.0V, load 20 Ω (150mA), rL=0.5Ω, efficiency loss 10% . Considering, suggest to use an inductance of 15 uH , rL<0.5Ω.

second, selection of capacitor

No considering the inductor with equivalent series resistor(ESR), output voltage ripple is:

$$r = \frac{\Delta V_{out}}{V_{out}} = \frac{D}{R_{load} C f}$$

considering the inductor's ESR, the output ripple will be increase:

$$r' = r + \frac{I_{max} \cdot R_{ESR}}{V_{out}}$$

Suggest to use Tantalum type with the low ESR or more parallel-resistor.

Third, selection of diode

It is recommended that the diode have great effect to DC-DC efficiency, we suggest to use schottky diode with the lower positive turn-on voltage and the lower corresponsive time. For example, 1N5817、1N5819 .

Fourth, selection of input capacitor

Power supply is stably, even if no input capacitor, DC-DC can output voltage with the lower ripple and the lower noise. But we suggest to connect with the capacitor of 10uF or more when the power supply was far away DC-DC, for minish the output noise.

Testing circuit:

(1) Test foldback voltage

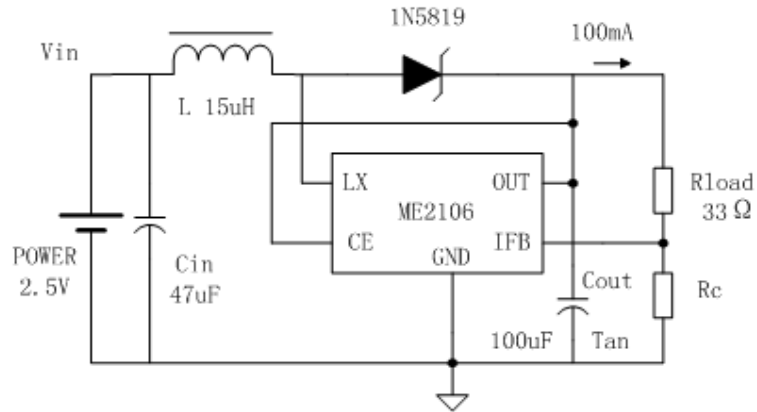

(2) Test startup voltage

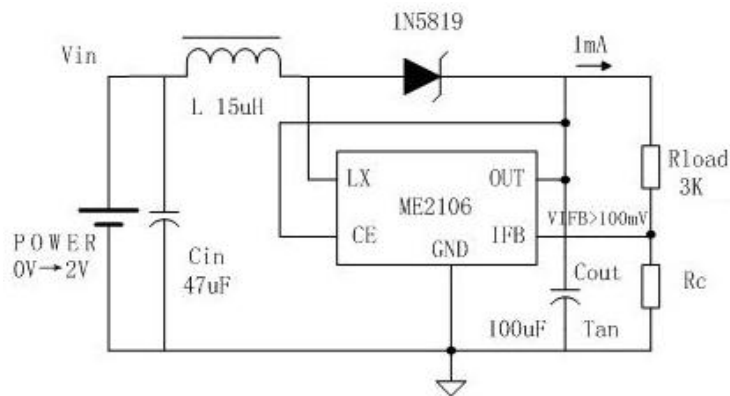

(3) Test holding voltage

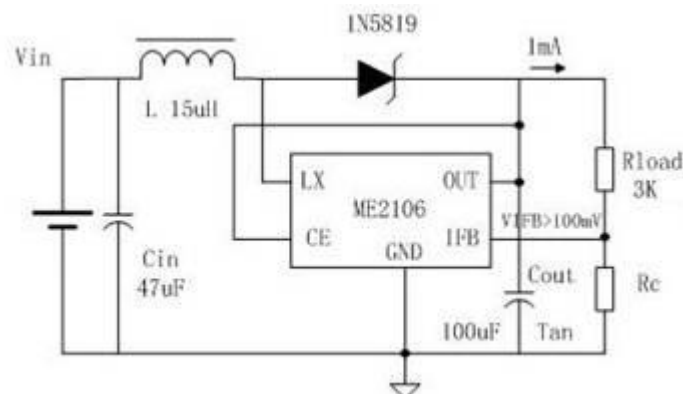

(4) Test supply current

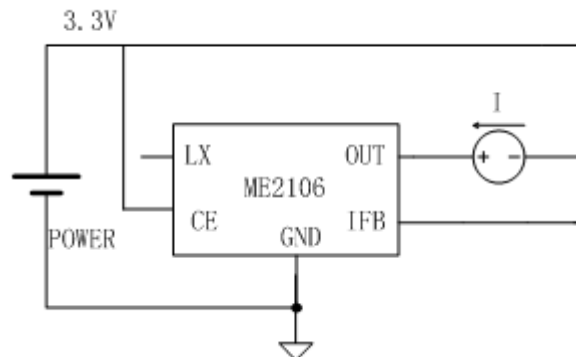

(5) Test Oscillation Frequency and Duty Ratio

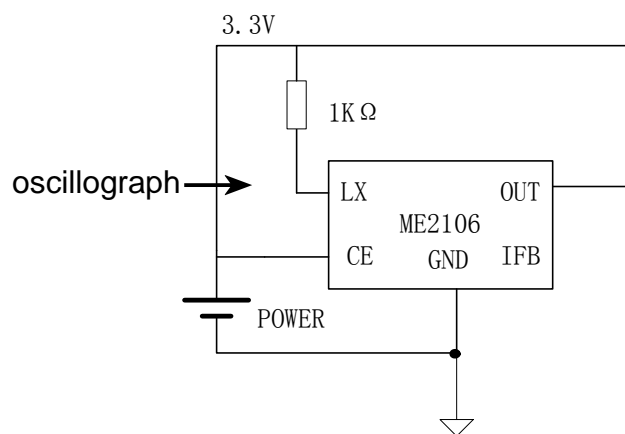

(6) Test switching current

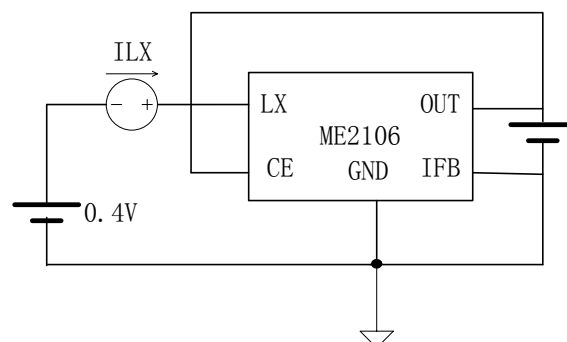

(7) Test switch leakage current

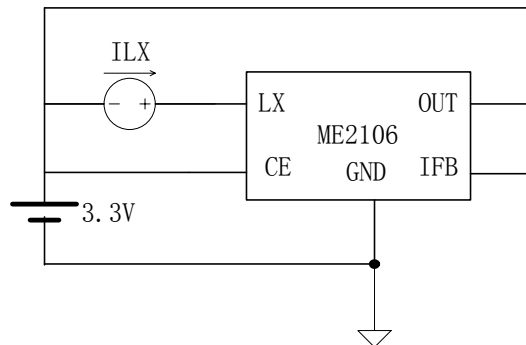

(8) Test CE high voltage

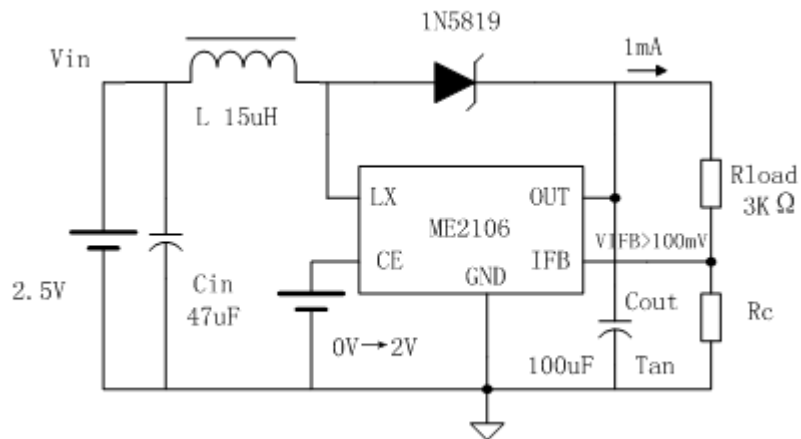

(9) Test CE low voltage

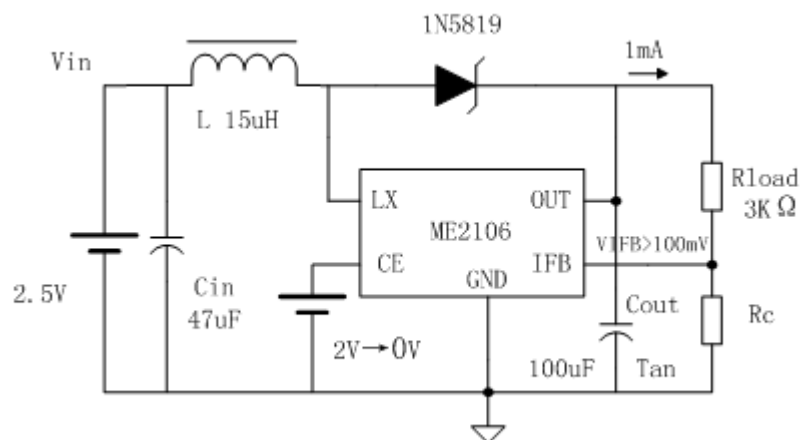

Operating Characteristics:

(1) Input Voltage VS. Efficiency

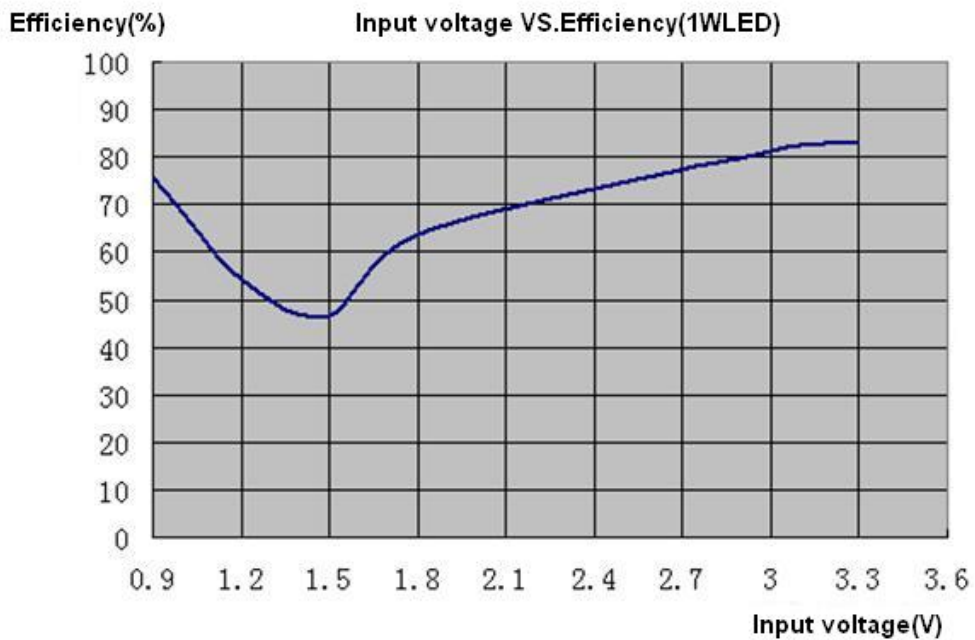
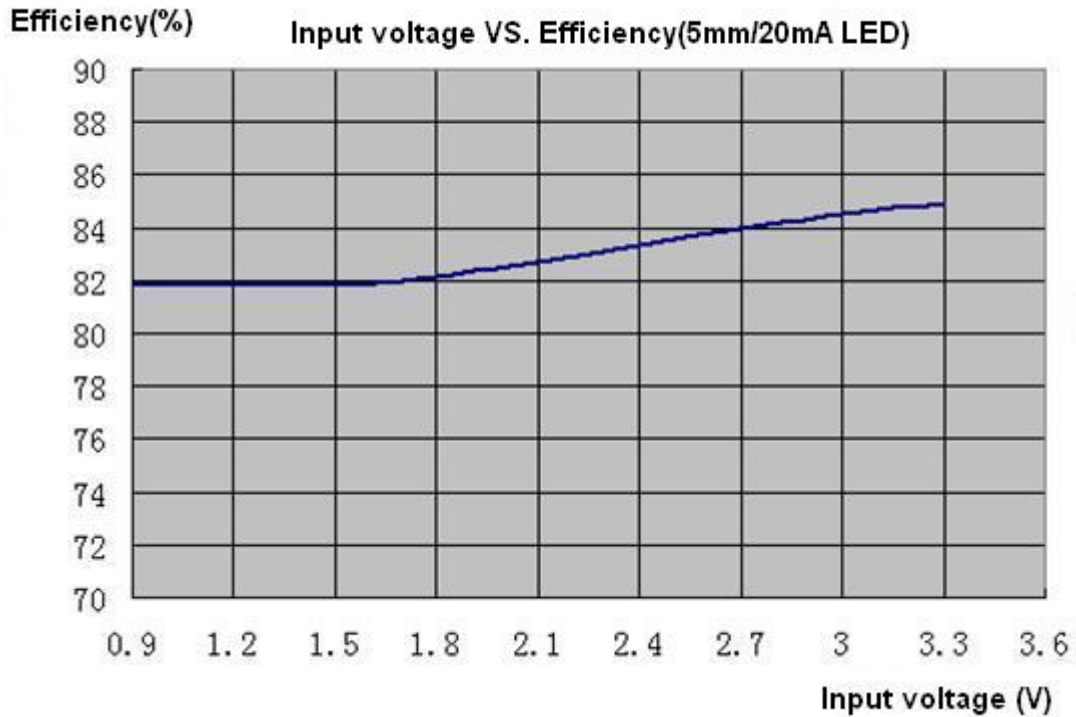

(2) Input voltage VS. output current

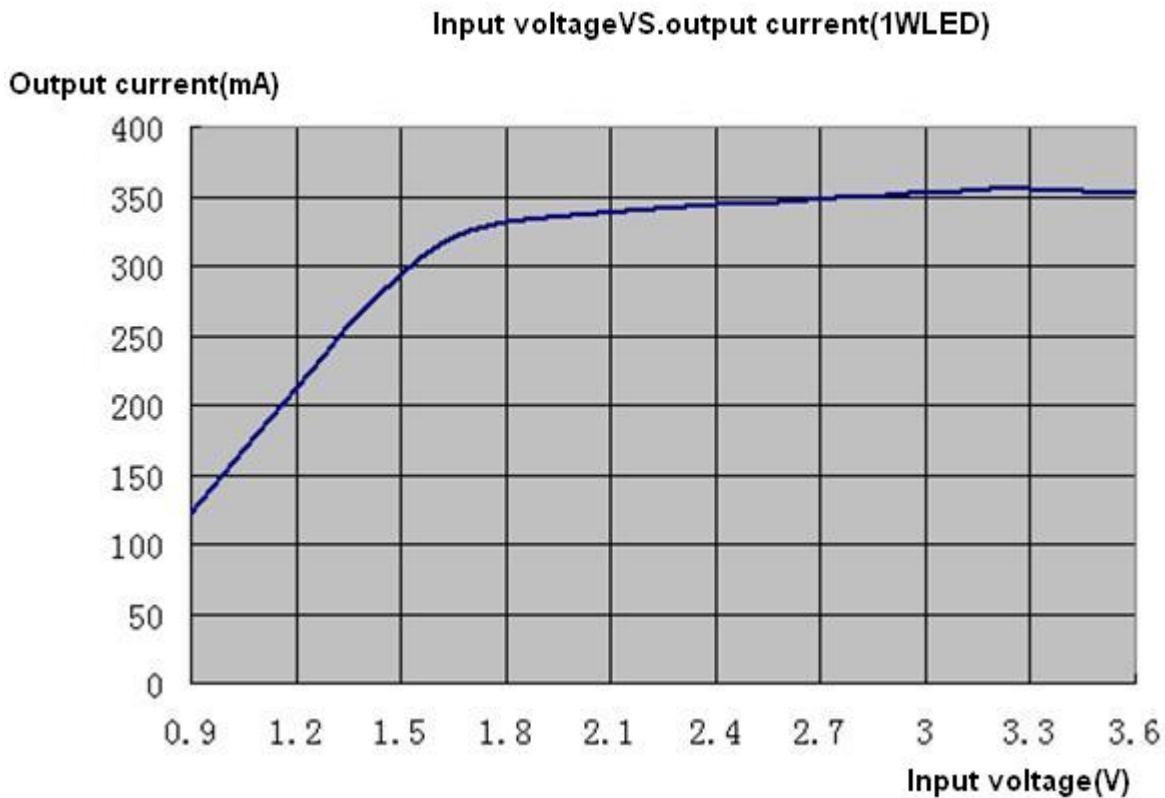
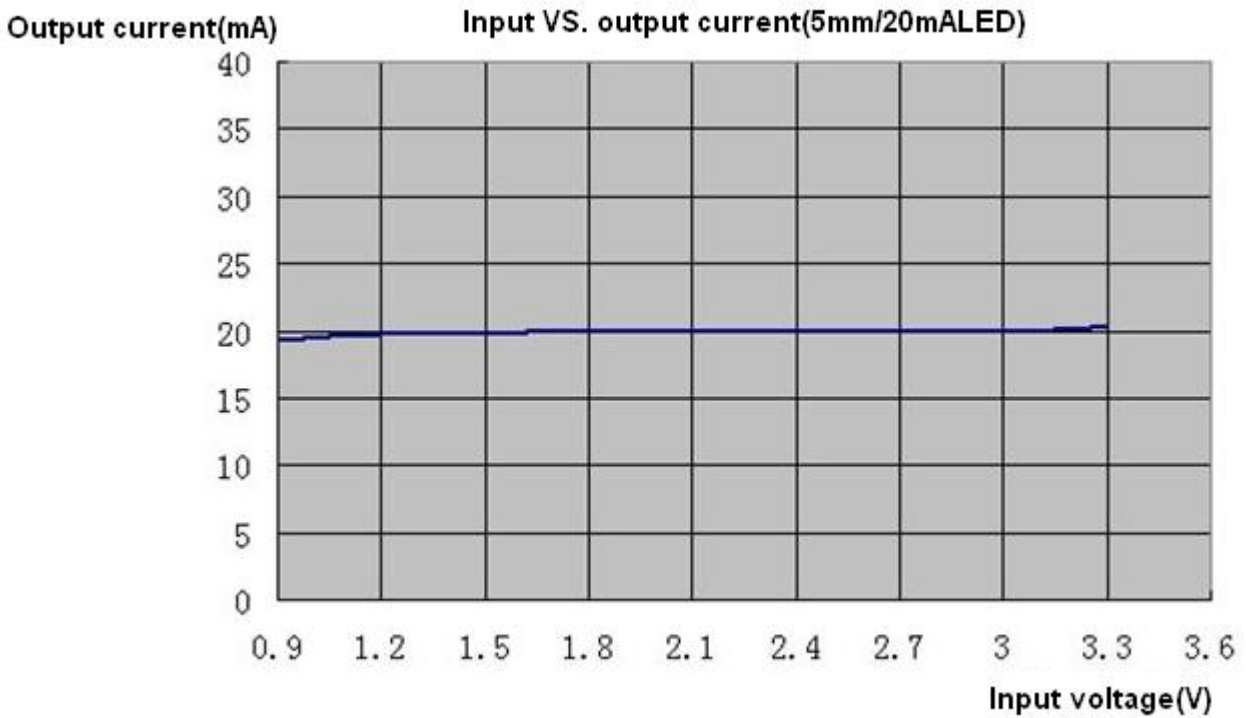

(3) Input voltage VS. Input current

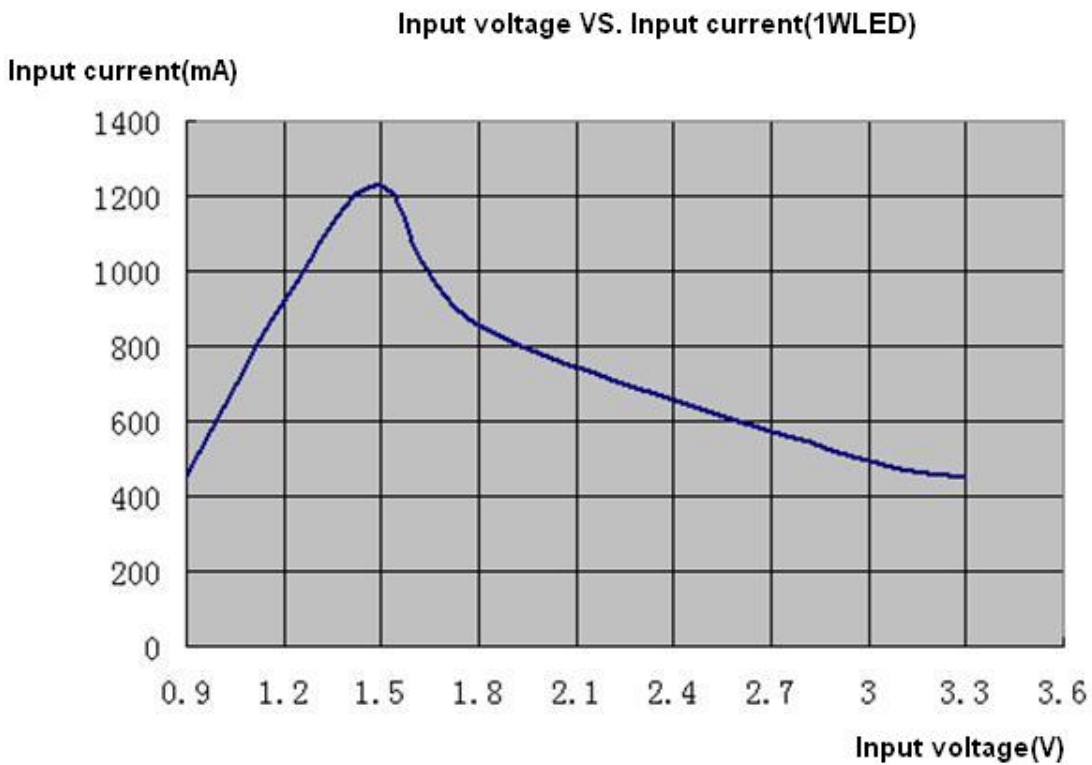
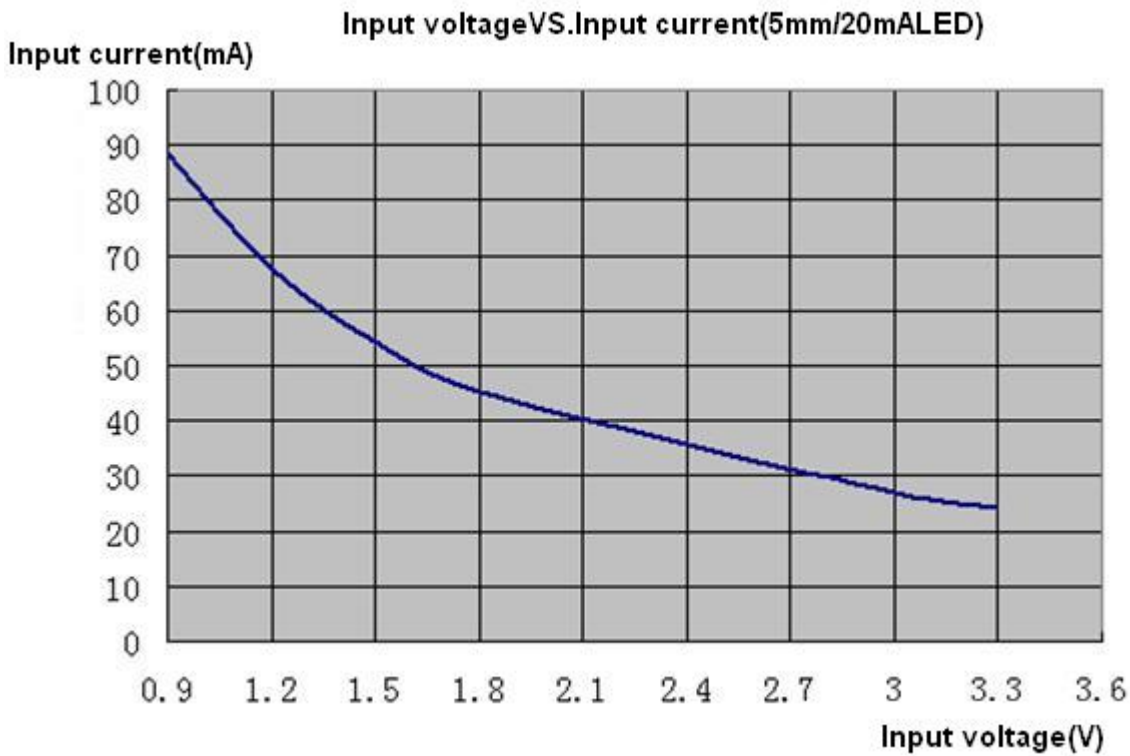

(4) Input volatage VS.Feedback voltage

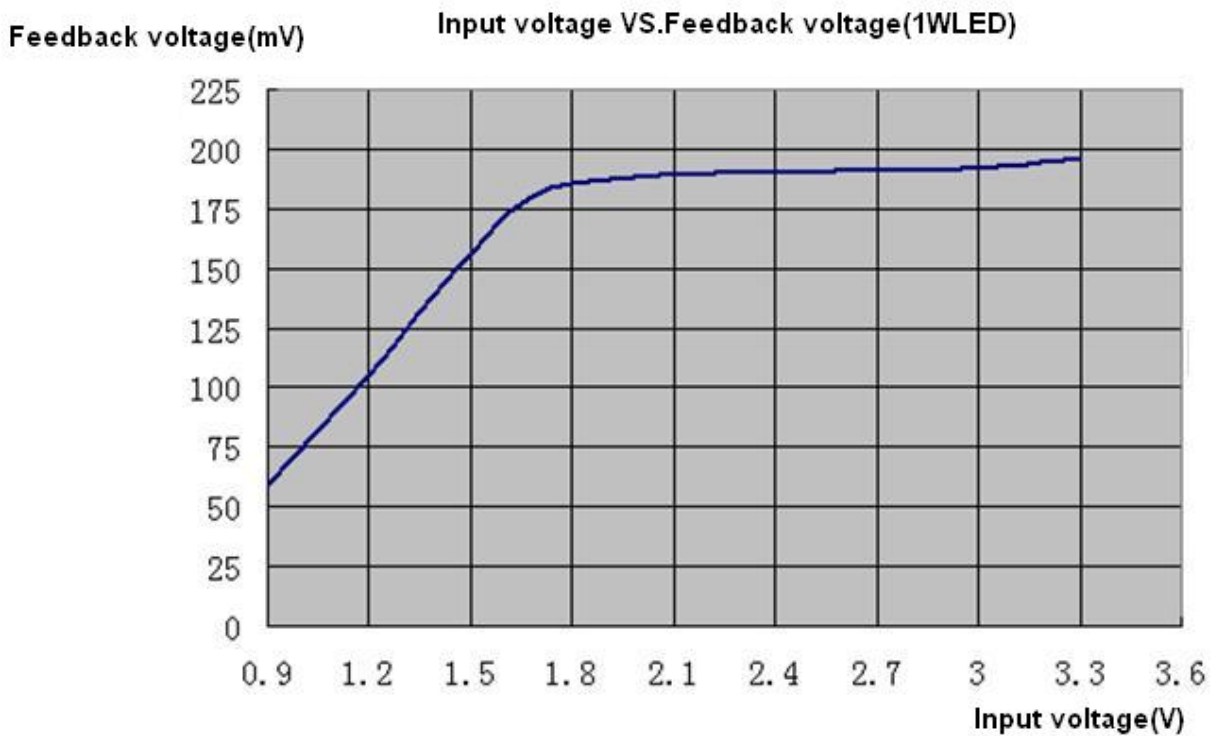
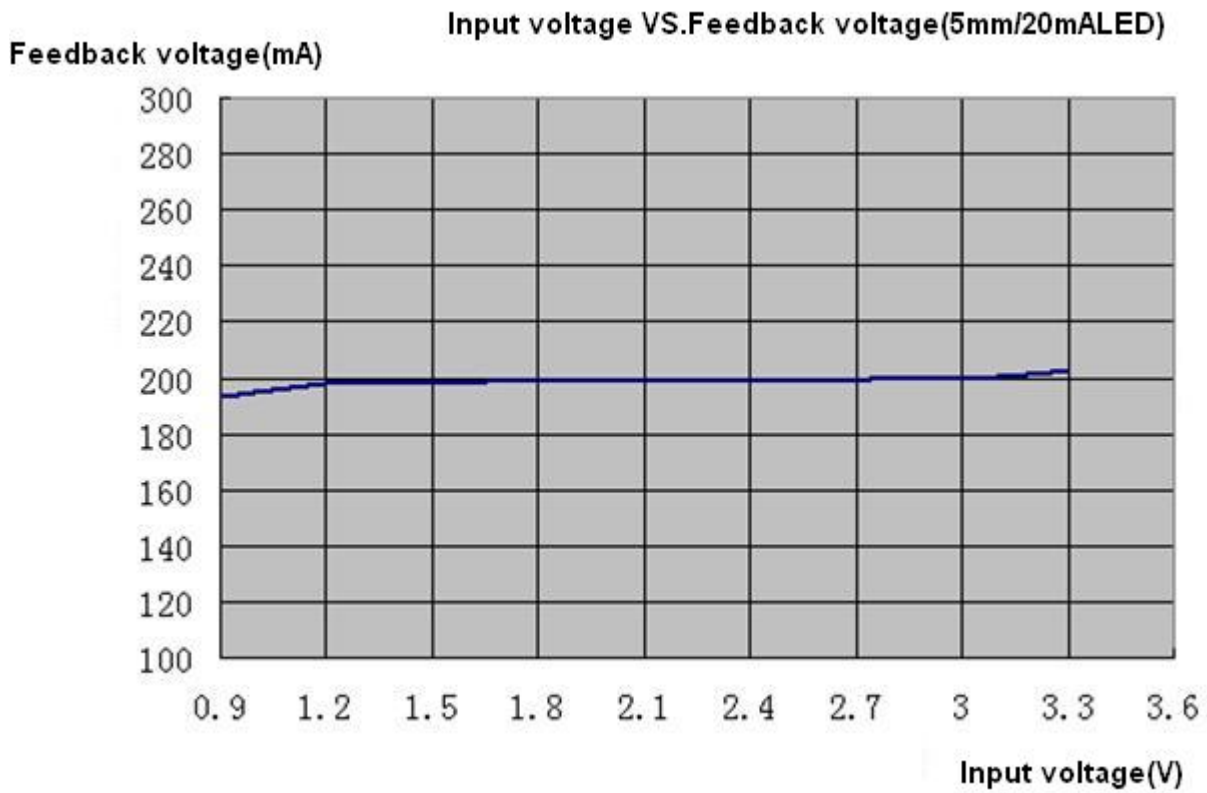

(5) Temperature VS. Feedback Voltage(tow Parallel 5mm/20mA LED)

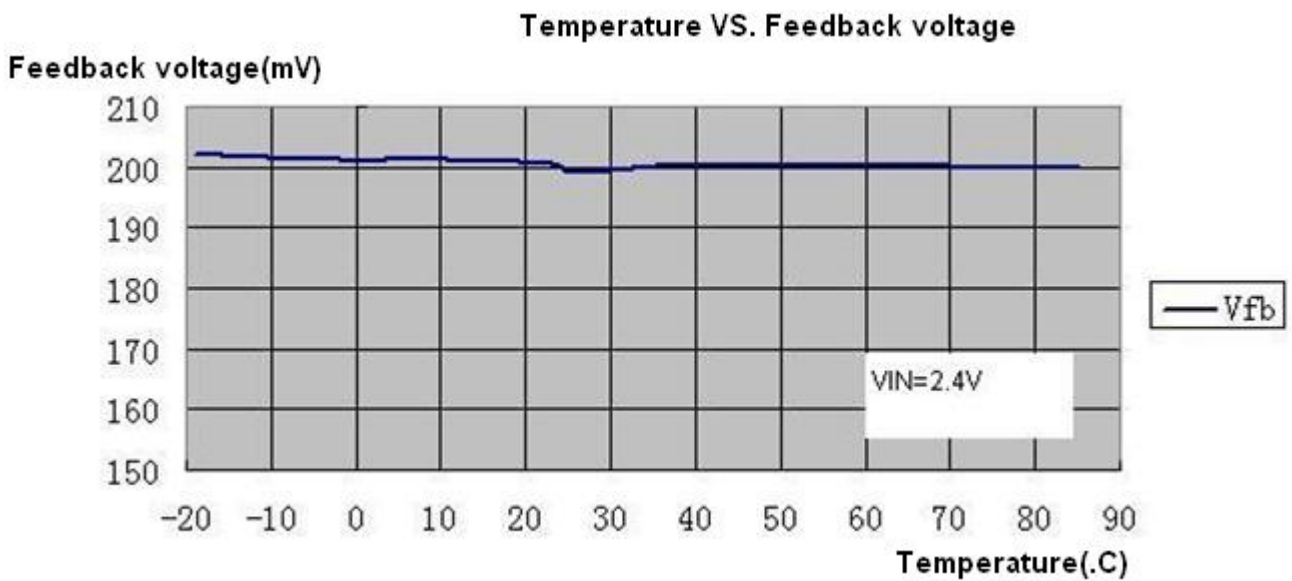
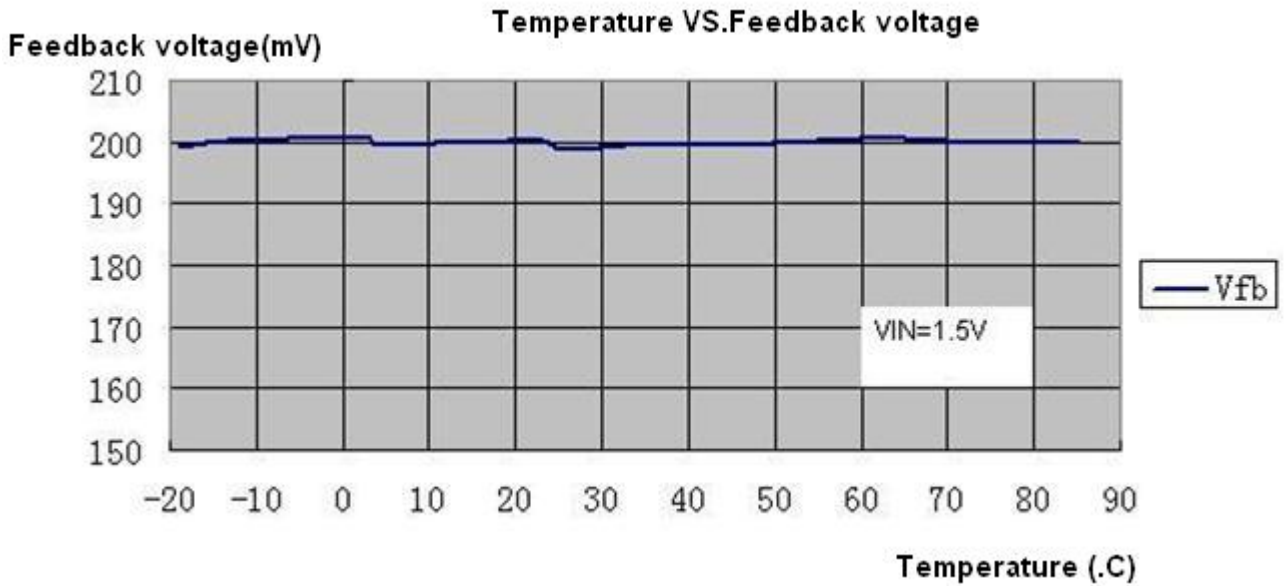

Package Dimensions:

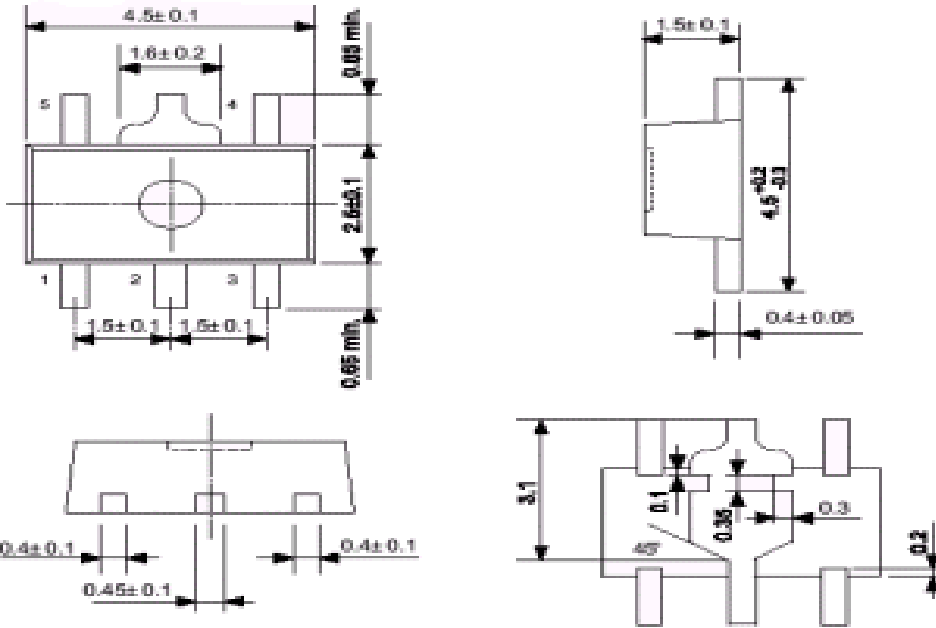

SOT89-5

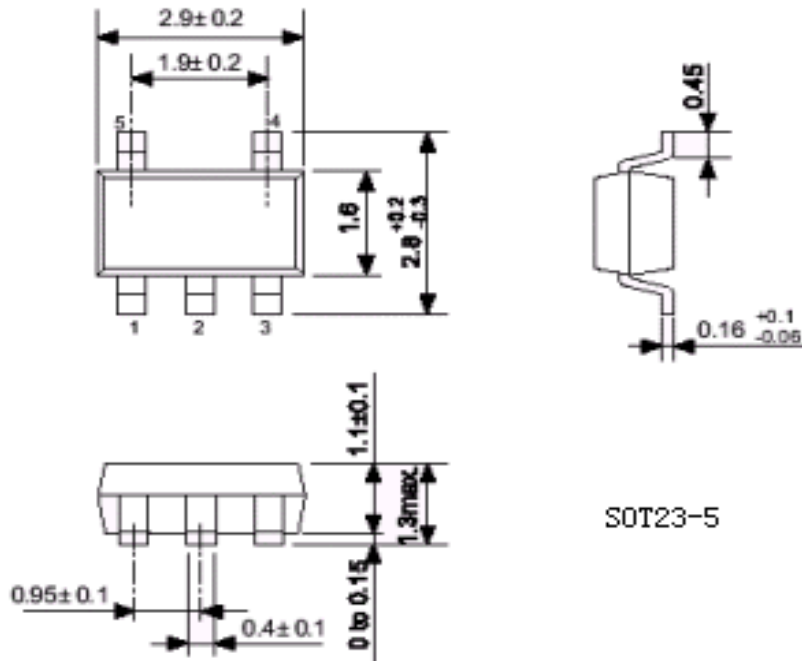

SOT23-5

- The information described herein is subject to change without notice.
- Nanjing Micro One Electronics Inc is not responsible for any problems caused by circuits or diagrams described herein whose related industrial properties, patents, or other rights belong to third parties. The application circuit examples explain typical applications of the products, and do not guarantee the success of any specific mass-production design.
- Use of the information described herein for other purposes and/or reproduction or copying without the express permission of Nanjing Micro One Electronics Inc is strictly prohibited.
- The products described herein cannot be used as part of any device or equipment affecting the human body, such as exercise equipment, medical equipment, security systems, gas equipment, or any apparatus installed in airplanes and other vehicles, without prior written permission of Nanjing Micro One Electronics Inc.
- Although Nanjing Micro One Electronics Inc exerts the greatest possible effort to ensure high quality and reliability, the failure or malfunction of semiconductor products may occur. The user of these products should therefore give thorough consideration to safety design, including redundancy, fire-prevention measures, and malfunction prevention, to prevent any accidents, fires, or community damage that may ensue.