

Sound Processor for Car Audio

BU32107EFV-M

General Description

The BU32107EFV-M is a Sound Processor for Car Audio Systems that includes DSP, Codec(ADC, DAC) and Fader Volume. It achieves very low Output Noise Voltage, 2 μ Vrms(Typ)(Fader Volume=- ∞ dB). Therefore, low noise Car Audio Systems can be realized easily by using BU32107EFV-M.

Features

- AEC-Q100 Qualified^(Note 1)
 - 2ch $\Delta\Sigma$ ADC: S/N=100dB
 - 6ch $\Delta\Sigma$ DAC: S/N=100dB
 - 6ch Independent Analog Fader Volume
 - Digital 4 Inputs/Outputs
 - Sampling Rate Converter(SRC)
 - f_s : 8k/16k/24k/32k/44.1k/48k/88.2k/96kHz
 - (S/PDIF f_s : 16k/24k/32k/44.1k/48k/88.2k/96kHz)
 - Analog Single-end: max 5 Inputs
 - Analog Mixing Single-end: max 4 Inputs
 - Hard Logic DSP
 - 13-Band EQ + 3-Band Tone, Loudness, X'over Filter, P²Bass, 16-Band Spectrum Analyzer, Noise Gen, Scaler, Time Alignment, DVol(Att/Boost/Output2), BEEP
 - Time Alignment
 - 2ch-input Mode: 21.3ms/ch,
 - 4ch-input Mode: 10.6ms/ch
- (Note 1): Grade3

Key Specifications

- Analog Power Supply Voltage: 4.75V to 6.00V
- Digital Power Supply Voltage: 3.00V to 3.60V
- Operating Temperature: -40°C to +85°C
- Maximum Input/Output Voltage: 2Vrms(Typ)
- Output Noise Voltage(Fader Volume=- ∞ dB):2 μ Vrms(Typ)
- S/N_{AD}(Input Selector-ADC-DOUT): 100dB(Typ)
- S/N_{DA}(DIN-DAC-Fader Volume OUT): 99dB(Typ)

Package

HTSSOP-B54
(0.65mm pitch)

W(Typ) x D(Typ) x H(Max)
18.50mm x 9.50mm x 1.00mm

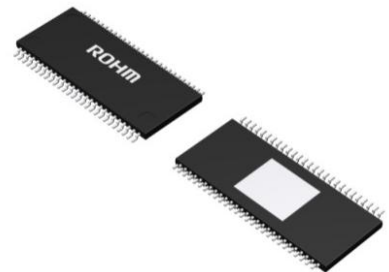

Applications

- Car Audio Systems

Typical Application Circuit

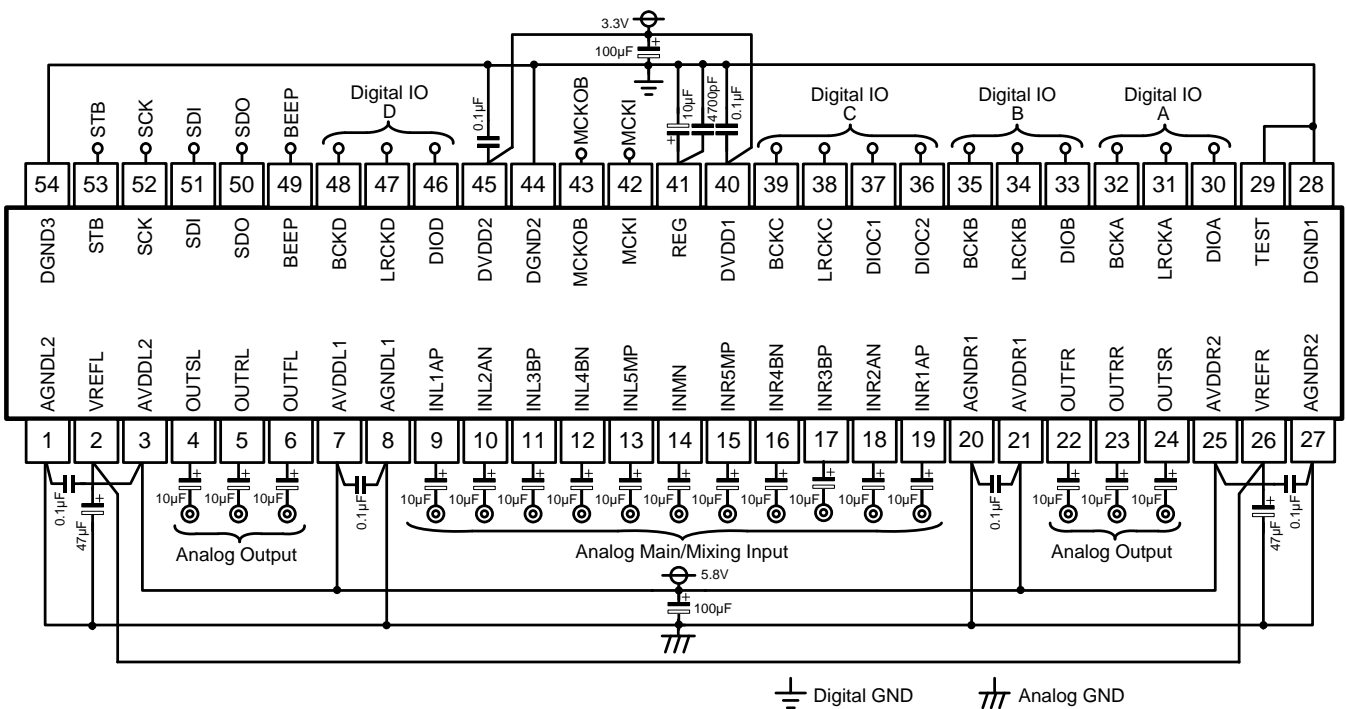

Figure 1. Typical Application Circuit Diagram

○Product structure : Silicon monolithic integrated circuit ○This product is not designed protection against radioactive rays

Contents

General Description 1

Features..... 1

Key Specifications 1

Package..... 1

Applications 1

Typical Application Circuit 1

Contents 2

Function..... 3

Pin Configuration 4

Pin Descriptions..... 4

Block Diagram 5

Signal Flow 6

Description of Blocks 7

 (1) MCK(Master Clock)..... 7

 (2) SRC(Sampling Rate Converter)..... 8

 (3) Mixing 9

 (4) Fader Input Selector 10

 (5) Analog Input Selector..... 11

 (6) Analog Mixing Input..... 12

 (7) Digital IO Selector 13

 (8) Digital IO Format..... 15

 (9) Digital ExtIO(Digital Input2/Digital Output2) 16

 (10) Time Alignment Mode 17

 (11) Surround Mode 18

 (12) Filter Coefficient Direct Setup 19

 (13) Spectrum Analyzer..... 22

 (14) BEEP 23

 (15) Fader Volume Advanced Switch 25

 (16) Mixing Advanced Switch 28

 (17) Advanced Switch(Other than Fader Volume and Mixing)..... 31

 (18) Sync Error Detection..... 35

Absolute Maximum Ratings(Ta=25°C)..... 36

Thermal Resistance..... 36

Recommended Operating Condition..... 36

Electrical Characteristics: Digital System..... 36

Electrical Characteristics: Analog System..... 37

Measurement Circuit..... 39

Pin Measurement Circuit..... 40

Typical Performance Curves..... 41

3 Wires Serial Audio Data Format & Master Clock Specification 55

S/PDIF Specification..... 56

4 Wires(SPI) Control Signal Specification..... 57

2 Wires Control Signal Specification 59

Select Address & Data 61

Command Specification 65

Application Example 105

I/O Equivalence Circuit 106

Application Information 108

 (1) Absolute Maximum Rating Voltage 108

 (2) About the Signal Input Pins 108

 (3) The REG Pin External Capacitor 108

 (4) Circuit Current..... 108

 (5) Mixing(Bias Circuit for Mixing) 108

 (6) Power Supply Sequence for Start-up and Shut Down 109

 (7) RAM Clear 110

 (8) Input-and-Output Delay..... 110

Operational Notes..... 111

Abbreviations 113

Ordering Information..... 114

Marking Diagram 114

Physical Dimension Tape and Reel Information..... 115

Revision History..... 116

Function

Function	Specifications	
Input Selector (Analog)	<ul style="list-style-type: none"> Analog Single-end max 5 inputs Possible to select Single-end/GND ISO(Diff) 3 inputs 	
Input Selector (Analog Mixing)	<ul style="list-style-type: none"> Analog Single-end max 4 inputs Possible to select Single-end/GND ISO(Diff) 2 inputs 	
Input Gain	<ul style="list-style-type: none"> 36dB to 0dB/1dB step 	
Input/Output Selector (Digital)	<ul style="list-style-type: none"> Digital 4 inputs/outputs SRC $f_s(\text{input})=8\text{k}/16\text{k}/24\text{k}/32\text{k}/44.1\text{k}/48\text{k}/88.2\text{k}/96\text{kHz}$(S/PDIF: f_s: 16kHz to 96kHz) $f_s(\text{output})=44.1\text{k}/48\text{kHz}$ 	
13-Band EQ + 3-Band Tone (Bass/Middle/Treble)	[13-Band EQ] <ul style="list-style-type: none"> +24dB to -24dB/2dB step $f_0=50\text{Hz}$ to 12.5kHz $Q=2.2/4.7$ <div style="text-align: right;"><i>(Note 1), (Note 3)</i></div>	
	DSP	[3-Band Tone](Bass/Middle/Treble) <ul style="list-style-type: none"> +12dB to -12dB/2dB step $f_c=40/63/100/160\text{Hz}$(Bass: 1st order shelf-type) $f_0=400/630/1\text{k}/1.6\text{kHz}$(Middle: $Q=0.2$) $f_c=2.5\text{k}/4\text{k}/6.3\text{k}/10\text{kHz}$(Treble: 1st order shelf-type) <div style="text-align: right;"><i>(Note 1), (Note 3)</i></div>
Time Alignment DSP	<ul style="list-style-type: none"> 10.6ms/ch(4ch-input Mode) 21.3ms/ch(2ch-input Mode) 	
X'over Filter(Front/Rear) DSP	[HPF(2 nd /4 th order)] <ul style="list-style-type: none"> $f_c=25/31.5/40/50/63/80/100/125/160/200/250\text{Hz}$, Through Phase=0°, 180° <div style="text-align: right;"><i>(Note 3)</i></div>	
X' over Filter(Sub) DSP	[LPF(2 nd /4 th order)] <ul style="list-style-type: none"> $f_c=25/31.5/40/50/63/80/100/125/160/200/250\text{Hz}$, Through Phase=0°, 180° [HPF(4 th order)] <ul style="list-style-type: none"> $f_c=20/25/31.5/40/50/63/80/100/125/160/200\text{Hz}$, Through <div style="text-align: right;"><i>(Note 3)</i></div>	
Loudness DSP	<ul style="list-style-type: none"> 0dB to -15dB/1dB step LPF $f_c=30/40/50/63/80/100/125\text{Hz}$ HPF $f_c=3\text{k}/4\text{k}/5\text{k}/6.3\text{k}/8\text{k}/10\text{k}/12.5\text{kHz}$ HiBoost=0/0.2/0.55/1.0 <div style="text-align: right;"><i>(Note 2)</i></div> <div style="text-align: right;"><i>(Note 3)</i></div>	
P ² Bass(Bass Boost) DSP	<ul style="list-style-type: none"> 12dB to 0dB/1dB step $f_c=54/68/86/108/134/172/214\text{Hz}$, Through <div style="text-align: right;"><i>(Note 2)</i></div>	
16-Band Spectrum Analyzer DSP	<ul style="list-style-type: none"> $f_0=20\text{Hz}$ to 20kHz(16-point) $Q=2.4/3.6/5.1/7.5$ Mode: Averaging/Peak Hold/Level Meter 36dB to 0dB/2dB step 	
Noise Gen DSP	<ul style="list-style-type: none"> White Noise/Pink Noise 	
BEEP DSP	<ul style="list-style-type: none"> BEEP Level=0dB to -79dB/0.5dB step, -∞dB <div style="text-align: right;"><i>(Note 1)</i></div>	
DVol(Att/Boost) DSP	<ul style="list-style-type: none"> Att: 0dB to -95.5dB/0.5dB step, -∞dB Boost: 36dB to 0dB/0.5dB step, -∞dB <div style="text-align: right;"><i>(Note 1)</i></div>	
DVol(Output2) DSP	<ul style="list-style-type: none"> 0dB to -79dB/0.5dB step, -∞dB 	
Scaler DSP	<ul style="list-style-type: none"> PreScaler: 0dB to -84dB/12dB step PostScaler: 84dB to 0dB/12dB step 	
Fader Volume DSP	<ul style="list-style-type: none"> 0dB to -79dB/1dB step, -∞dB <div style="text-align: right;"><i>(Note 1)</i></div>	
AVol(AMix/DMix) DSP	<ul style="list-style-type: none"> AVol(AMix): +6dB to -63dB/1dB step, -∞dB AVol(DMix): 0dB to -69dB/1dB step, -∞dB <div style="text-align: right;"><i>(Note 1)</i></div>	

(Note 1) Possible to use "Advanced Switch" to prevent pop noise.

(Note 2) Possible to use "Advanced Switch" to prevent pop noise. [Possible only for Gain switching.]

(Note 3) Possible to sets five coefficients of 2nd order IIR Filter directly.

Pin Configuration

(TOP VIEW)

54	53	52	51	50	49	48	47	46	45	44	43	42	41	40	39	38	37	36	35	34	33	32	31	30	29	28
DGND3	STB	SCK	SDI	SDO	BEEP	BCKD	LRCKD	DIOD	DVDD2	DGND2	MCKOB	MCKI	REG	DVDD1	BCKC	LRCKC	DIOC1	DIOC2	BCKB	LRCKB	DIOB	BCKA	LRCKA	DIOA	TEST	DGND1
AGNDL2	VREFL	AVDDL2	OUTSL	OUTRL	OUTFL	AVDDL1	AGNDL1	INL1AP	INL2AN	INL3BP	INL4BN	INL5MP	INMN	INR5MP	INR4BN	INR3BP	INR2AN	INR1AP	AGNDR1	AVDDR1	OUTFR	OUTRR	OUTSR	AVDDR2	VREFR	AGNDR2
1	2	3	4	5	6	7	8	9	10	11	12	13	14	15	16	17	18	19	20	21	22	23	24	25	26	27

Figure 2. Pin Configuration

Pin Descriptions

Pin No.	Pin	Description	Unused pins	Pin No	Pin	Description	Unused pins	
1	AGNDL2	Analog Lch GND2	-	28	DGND1	Digital GND1	-	
2	VREFL	Lch Reference	-	29	TEST	Test Input	DGND	
3	AVDDL2	Analog Lch Power Supply2	-	30	DIOA	Digital Data I/O A	DGND	
4	OUTSL	Sub Lch Output	Open	31	LRCKA	Digital LR Clock I/O A	DGND	
5	OUTRL	Rear Lch Output	Open	32	BCKA	Digital Bit Clock I/O A	DGND	
6	OUTFL	Front Lch Output	Open	33	DIOB	Digital Data I/O B	DGND	
7	AVDDL1	Analog Lch Power Supply1	-	34	LRCKB	Digital LR Clock I/O B	DGND	
8	AGNDL1	Analog Lch GND1	-	35	BCKB	Digital Bit Clock I/O B	DGND	
9	INL1AP	Selector Lch-Single1-DiffAP Input		36	DIOC2	Digital Data I/O C2	DGND	
10	INL2AN	Selector Lch-Single2-DiffAN Input		37	DIOC1	Digital Data I/O C1	DGND	
11	INL3BP	Selector Lch-Single3/M1-DiffBP/MAP Input		38	LRCKC	Digital LR Clock I/O C	DGND	
12	INL4BN	Selector Lch-Single4/M2-DiffBN/MAN Input		39	BCKC	Digital Bit Clock I/O C	DGND	
13	INL5MP	Selector Lch-Single5/M3-DiffCP/MBP Input		40	DVDD1	Digital Power Supply1	-	
14	INMN	Selector SingleM4-DiffCN/MBN Input		41	REG	Regulator Output for Internal Logic	-	
15	INR5MP	Selector Rch-Single5/M3-DiffCP/MBP Input		42	MCKI	Master Clock Input	-	
16	INR4BN	Selector Rch-Single4/M2-DiffBN/MAN Input		43	MCKOB	Master Clock Invert Signal Output	Open	
17	INR3BP	Selector Rch-Single3/M1-DiffBP/MAP Input		44	DGND2	Digital GND2	-	
18	INR2AN	Selector Rch-Single2-DiffAN Input		45	DVDD2	Digital Power Supply2	-	
19	INR1AP	Selector Rch-Single1-DiffAP Input		46	DIOD	Digital Data I/O D	DGND	
20	AGNDR1	Analog Rch GND1		-	47	LRCKD	Digital LR Clock I/O D	DGND
21	AVDDR1	Analog Rch Power Supply1		-	48	BCKD	Digital Bit Clock I/O D	DGND
22	OUTFR	Front Rch Output		Open	49	BEEP	BEEP Command Input	DGND
23	OUTRR	Rear Rch Output		Open	50	SDO	Command Data Output	Open
24	OUTSR	Sub Rch Output		Open	51	SDI	Command Data Input	-
25	AVDDR2	Analog Rch Power Supply2		-	52	SCK	Command Clock Input	-
26	VREFR	Rch Reference		-	53	STB	Command Strobe Input	-
27	AGNDR2	Analog Rch GND2		-	54	DGND3	Digital GND3	-

Block Diagram

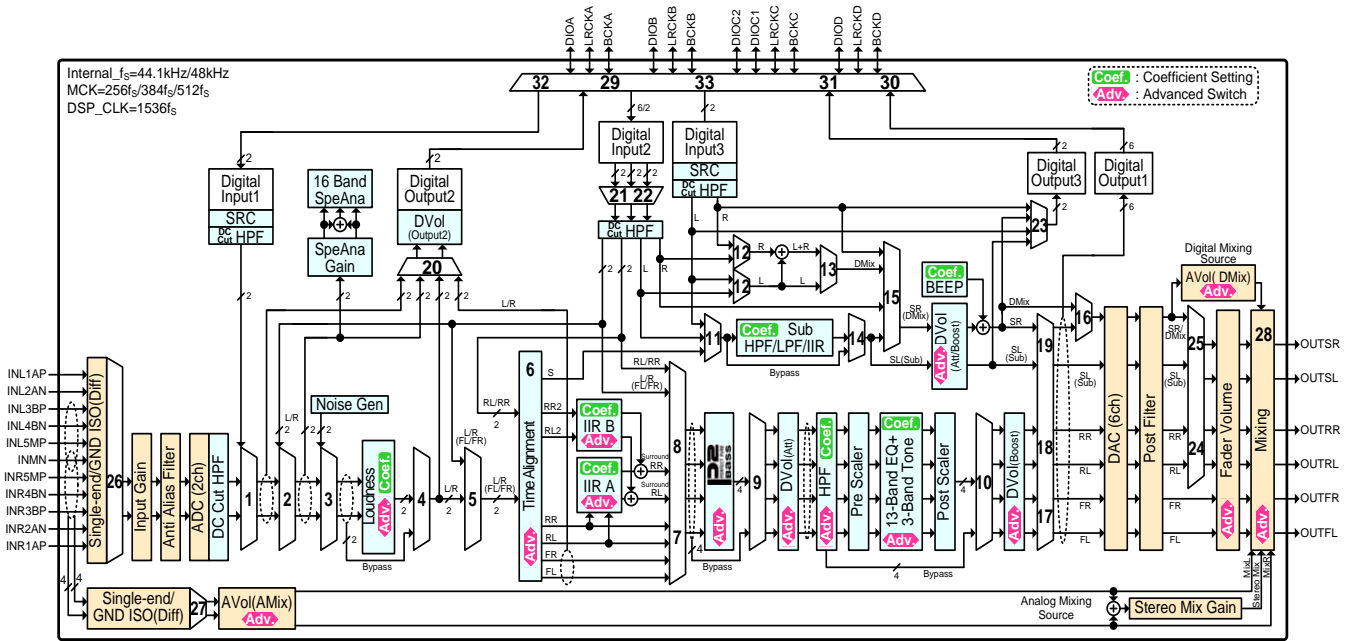

Figure 3. Block Diagram

■ Digital Input/Output Format

- 64f_s(2ch)
- SRC 64f_s(2ch Inputs): 8kHz to 96kHz
- SRC S/PDIF: 16kHz to 96kHz
- f_s(Output): 44.1kHz/48kHz
- 1st/S/Left-Justified/Right-Justified
- 16/20/24bit

■ DC Cut HPF

- 1st order HPF: f_c=1Hz, Through

■ 16-Band Spectrum Analyzer

- Gain=36dB to 0dB/2dB step
- f₀=20Hz to 20kHz(16-point)
- Q=2.4/3.6/5.1/7.5

Common setup for all bands

■ Noise Gen

- White Noise/Pink Noise

■ Loudness(1st order)

- 0dB to -15dB/1dB step
- Advanced Switch
- HiBoost=0/0.2/0.55/1
- LPF f_c=30/40/50/63/80/100/125Hz
- HPF f_c=3k/4k/5k/6.3k/8k/10k/12.5kHz
- Coefficient setting

■ Time Alignment Control

- 10.6ms/ch: 4ch-Independent Input
- 21.3ms/ch: 2ch-stereo Input
- FL/FR/RL/RR/S/RL2/RR2 Independent control

■ IIR A/IIR B(Surround)

- Advanced Switch
- Coefficient setting
- P²Bass(Bass Boost)
- f_c=54/68/86/108/134/172/214Hz, Through

- Gain=12dB to 0dB/1dB step

- Advanced Switch
- Front/Rear Independent control

■ DVol(Att/Boost)

- Att: 0dB to -95.5dB/0.5dB step, -∞dB
- Boost: 36dB to 0dB/0.5dB step, -∞dB
- 6ch Independent control
- Advanced Switch
- Front/Rear HPF(4th/2nd order)
- HPF: f_c=25/31.5/40/50/63/80/100/125/160/200/250Hz, Through
- Coefficient setting
- Phase=0°/180°

■ Scaler

- PreScaler: 0dB to -84dB/12dB step
- PostScaler: 84dB to 0dB/12dB step
- 13-Band EQ + 3-Band Tone(2nd order)

[13-Band EQ]

- Gain=±24dB/2dB step
- Advanced Switch
- f₀=fix, Q=2.2, 4.7

Common setup for all bands

- Coefficient setting
- [3-Band Tone](Bass/Middle/Treble)

- Gain=±12dB/2dB step
- Advanced Switch
- f_c=40/63/100/160Hz (Bass: 1st order shelf-type)
- f₀=400/630/1k/1.6kHz(Middle: Q=0.2)
- f_c=2.5k/4k/6.3k/10kHz (Treble: 1st order shelf-type)

- Coefficient setting
- [3-Band EQ](Instead of 3-Band Tone)

- Gain=±24dB/2dB step
- Advanced Switch
- f₀=20/31.5/20kHz, Q=2.2, 4.7

■ BEEP

- ATT=0dB to -79dB/0.5dB step, -∞dB

■ Sub LPF(4th/2nd order)/HPF(4th order)

- LPF: f_c=25/31.5/40/50/63/80/100/125/160/200/250Hz, Through
- Phase=0°/180°
- HPF: f_c=20/25/31.5/40/50/63/80/100/125/160/200Hz, Through

■ Coefficient setting

- Sub IIR
- Coefficient setting
- DVol(Output2)
- Gain=0dB to -79dB/0.5dB step

■ Input Gain

- Gain=36dB to 0dB/1dB step

■ AVol(AMix)

- Gain=+6dB to -63dB/1dB step, -∞dB
- Advanced Switch
- L/R Independent control

■ Stereo Mix Gain

- Gain=+6dB, 0dB

■ AVol(DMix)

- Gain=0dB to -69dB/1dB step, -∞dB
- Advanced Switch
- Fader Volume

- Gain=0dB to -79dB/1dB step, -∞dB
- Advanced Switch

- 6ch Independent control

■ Mixing

- Advanced Switch
- 6ch Independent control

Signal Flow

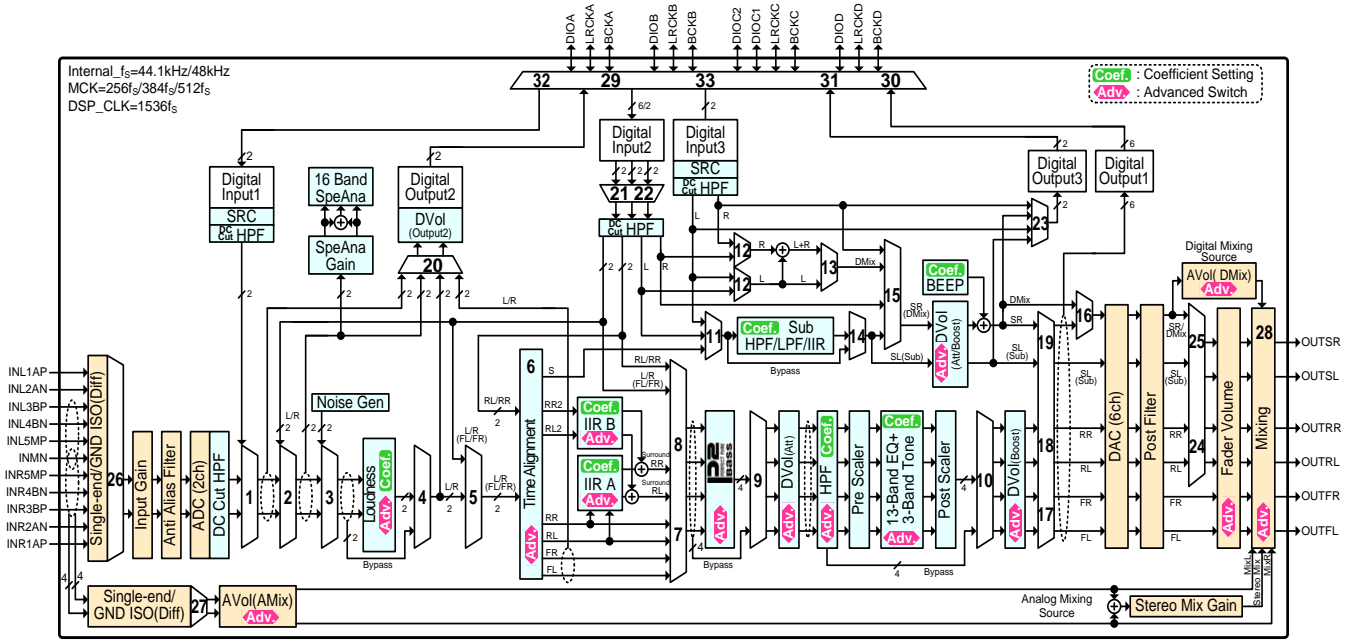

Figure 4. Signal Flow

No.	Select Address	Selector	No.	Select Address	Selector
1	0203(hex)[7]	DSP Input Selector	18	0207(hex)[3:2]	Digital Output1 Rear Selector
2	0203(hex)[5]	SpeAna Input Selector	19	0207(hex)[5:4]	Digital Output1 Sub Selector
3	0203(hex)[6]	Loudness Input Selector	20	0208(hex)[1:0]	Digital Output2 Selector
4	0002(hex)[3]	Loudness	21	0019(hex)[7]	Rear Input Selector(ExtIO)
5	0203(hex)[4]	Time Alignment Input Selector	22	0019(hex)[6]	Sub Input Selector(ExtIO)
6	0203(hex)[3]	Time Alignment Mode	23	0208(hex)[5:4]	Digital Output3 Selector
7	0205(hex)[6]	P ² Bass Input Selector(Front)	24	0102(hex)[1:0]	Rear Selector
8	0205(hex)[5:4]	P ² Bass Input Selector(Rear)	25	0102(hex)[5:4]	Sub Selector
9	0002(hex)[6]	P ² Bass	26	0103(hex)[2:0]	Analog Input Selector
10	0002(hex)[7]	X'over/EQ	27	0103(hex)[6:4]	Analog Mixing Input Selector
11	0206(hex)[7:6]	SL X'over Input Selector	28	0104(hex)[7:0], 0105(hex)[3:0]	Analog Mixing Source (FL, FR, RL, RR, SL, SR)
12	0206(hex)[0]	Digital Mixing Input Selector			
13	0206(hex)[1]	Digital Mixing Stereo Mix	29	0200(hex)[1:0]	Digital ExtIO IO Selector
14	0002(hex)[5]	SL X'over	30	0201(hex)[2:0]	Digital Output1 IO Selector
15	0206(hex)[5:4]	SR Volume Input Selector	31	0201(hex)[6:4]	Digital Output3 IO Selector
16	0109(hex)[6]	DAC Digital Mixing Mode	32	0202(hex)[3:0]	Digital Input1 IO Selector
17	0207(hex)[1:0]	Digital Output1 Front Selector	33	0202(hex)[7:4]	Digital Input3 IO Selector

Description of Blocks

(1) MCK(Master Clock)

An internal inverter and an X'tal oscillation circuit are formed by connecting X'tal to the MCKI pin and the MCKOB pin, and a Master Clock is generated by turning ON the DVDD power supply. The oscillation cannot be turned off by an external circuit. When using the Master Clock in an external device, connect an inverter to the MCKOB pin. The inverter has to be connected to the MCKOB pin in the shortest distance possible to ensure oscillation stability. Connect the external device to the output of the inverter connected to the MCKOB pin.

Moreover, it is also possible to input a clock directly into the MCKI pin. In this case, since there is no function to stop the inverter in the device during an oscillation, an inverted clock is being outputted to the MCKOB pin continuously.

Master Clock frequency can be set to $256f_s/384f_s/512f_s$ ($f_s=44.1\text{kHz}/48\text{kHz}$). Setup f_s Selector(0001(hex)[3]) and MCK Selector(0001(hex)[5:4]) to conform with the actual input frequency and f_s .

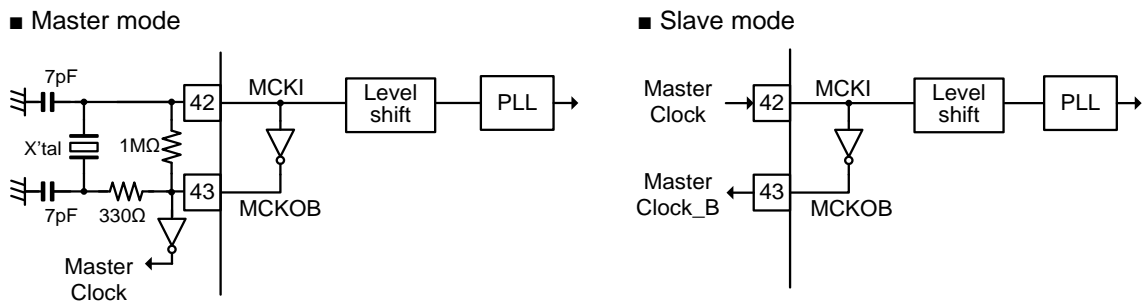

Figure 5. The MCKI/MCKOB Pin Circuit Diagram

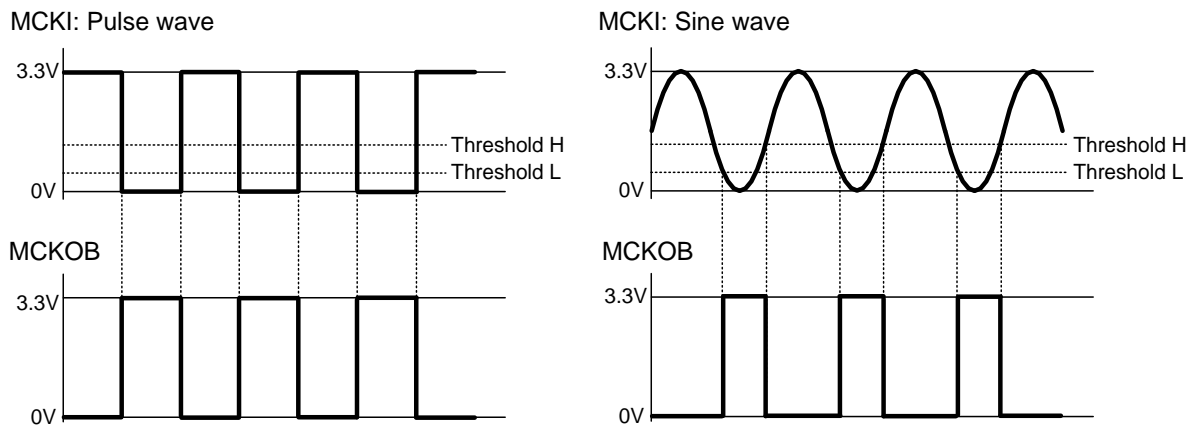

Figure 6. MCKOB Output

When MCK input to the MCKI pin stops, PLL and all the logic circuits stop. The 4-Wire, 2-Wire data also cannot be received.

(2) SRC(Sampling Rate Converter)

There is a SRC(Sampling Rate Converter) function in Digital Input1 and Digital Input3. Since audio data which is asynchronous with MCK can be converted to audio data which is synchronized with MCK in SRC($f_s=44.1\text{ k}/48\text{kHz}$, 24bit), audio data which is asynchronous MCK can be input as it is. Possible sampling frequencies for which audio data is inputted are 8k/16k/24k/32k/44.1k/48k/88.2k/96kHz.

The S/PDIF input except for the characteristic of interface is also supported in $f_s=16\text{k}/24\text{k}/32\text{k}/44.1\text{k}/48\text{k}/88.2\text{k}/96\text{kHz}$. The characteristic of interface is compliant with the [Electrical Characteristic of Digital System](#). The S/PDIF is supported in IEC60958-3: consumer applications.

When sampling frequency of input signal(period of LRCK) is changed, SRC detects the frequency change and mutes the output signal. Once the SRC detects that the input signal is stable for at least 101.5ms, it un-mutes the output signal.

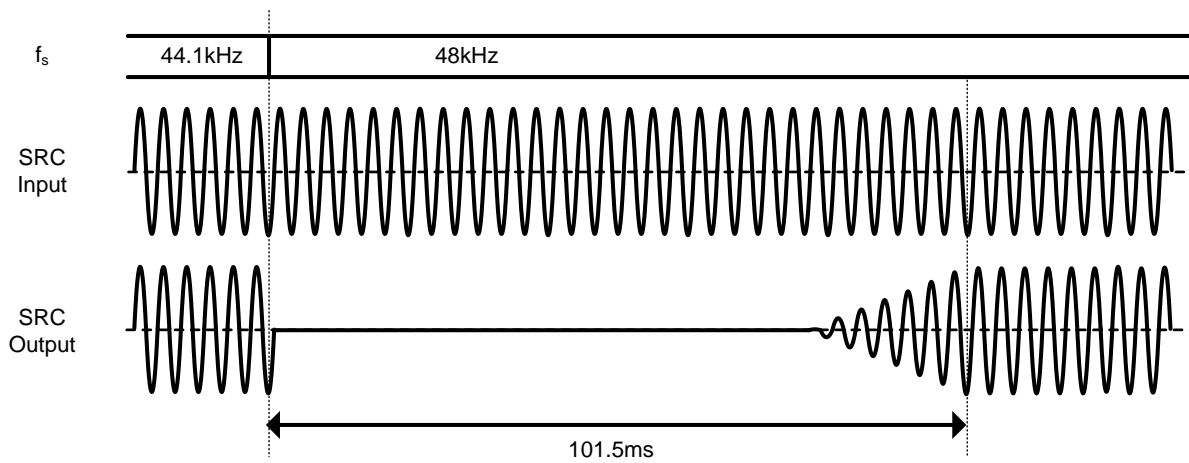

Figure 7. Example of SRC(In case that sampling frequency of input signal is changed from 44.1kHz to 48kHz)

(3) Mixing

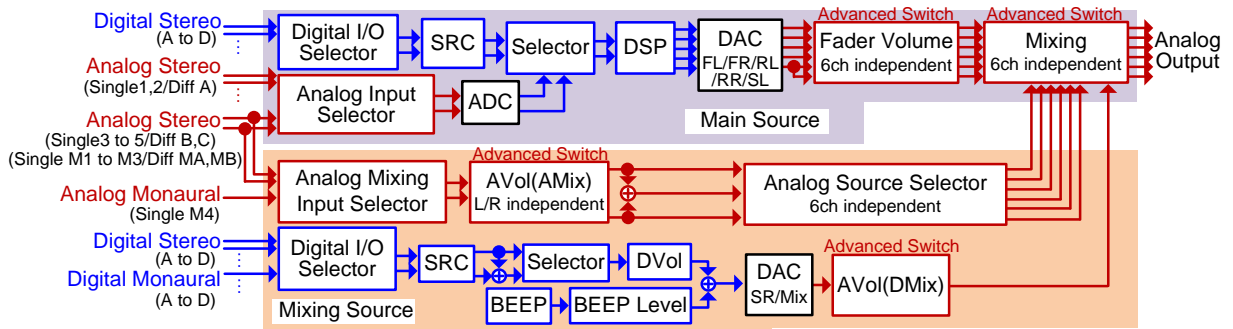

Figure 8. Mixing Image Diagram

It is possible to mix 2 Mixing signal(Analog/Digital) to 6ch output independently. Since Advanced Switch is possible in Mixing ON/OFF control, it is possible to reduce pop noise. There is no countermeasure against pop noise when the selector is setup without Advanced Switch. Therefore, when changing the selector setting, take countermeasures, such as setting Mixing=OFF, AVol=-∞dB.

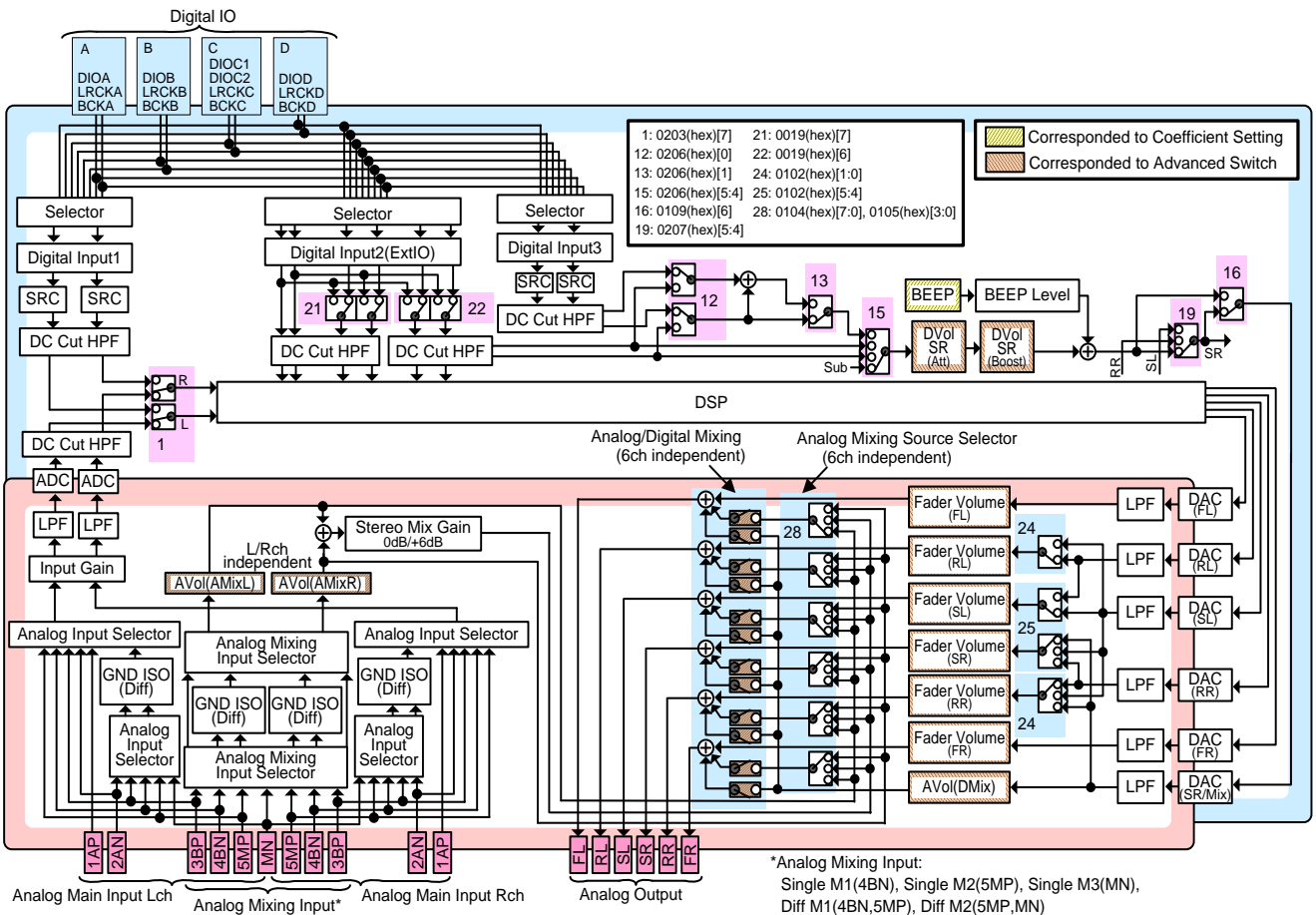

Figure 9. Mixing Diagram

SRch DAC is used for Digital Mixing. When Digital Mixing is used, set DAC Digital Mixing Mode 0109(hex)[6] (Selector No.16) as ON simultaneously. Furthermore, set it except SR(Rear Selector 0102(hex)[1:0]=00 or 10, Sub Selector 0102(hex)[5:4]=01 or 10) as Rear/Sub Selector (Selector No.24, 25) in 0102(hex) Fader Input Selector.

(4) Fader Input Selector

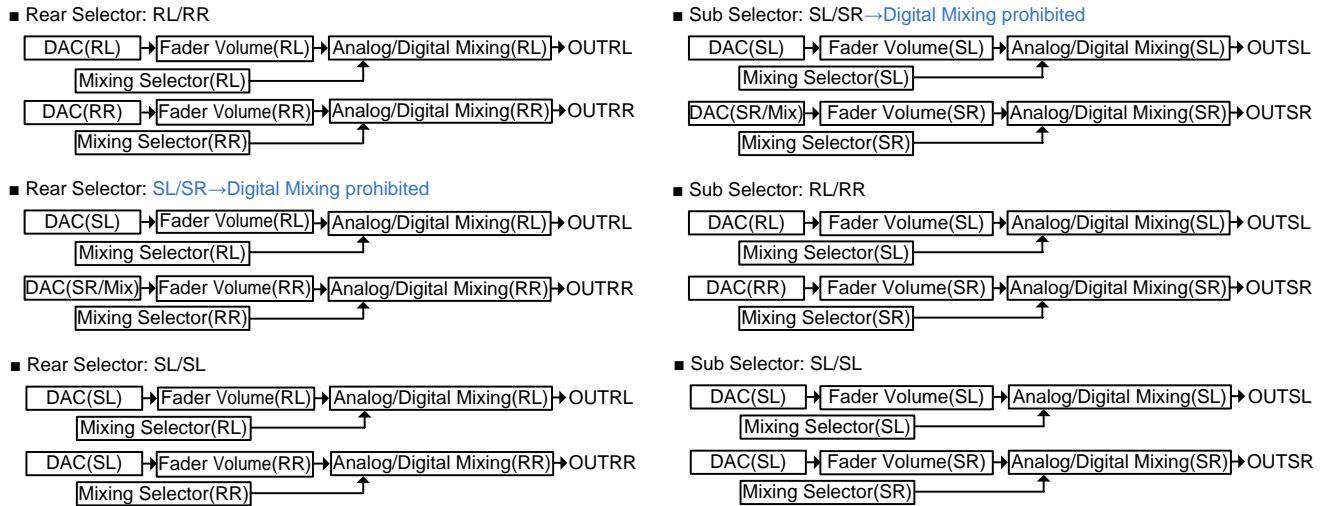

Figure 10. Fader Input Selector Image Diagram

Fader Input (Rear ch, Sub ch) can be select DAC Rear output or DAC Sub output. When 0109(hex) Digital Mixing is set up, set it except SRch(Rear Selector 0102(hex)[1:0]=00 or 10, Sub Selector 0102(hex)[5:4]=01 or 10) as Rear/Sub Selector.

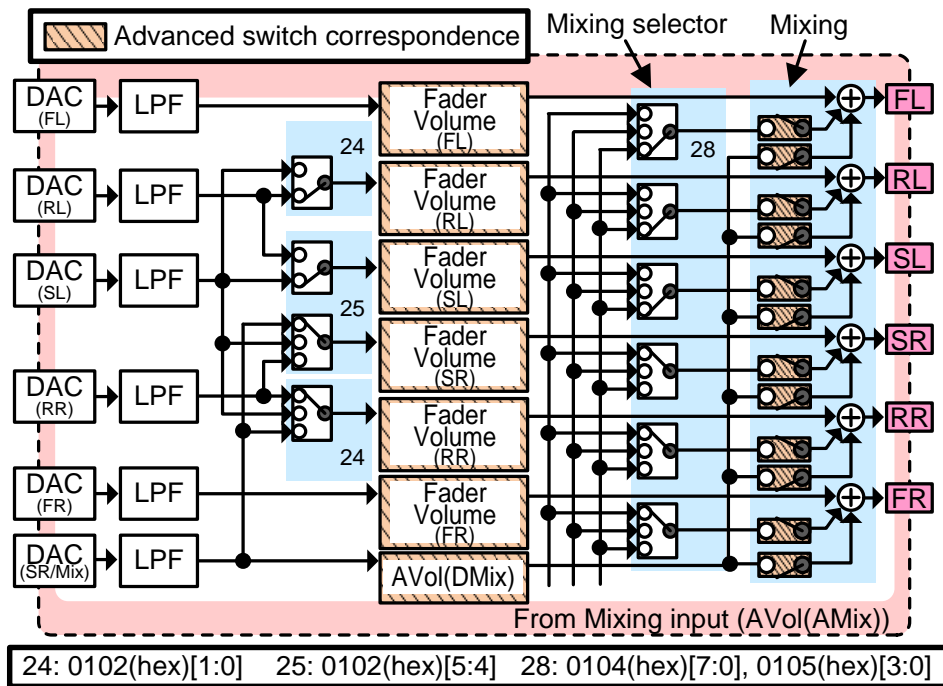

Figure 11. Fader Input Selector Diagram

(5) Analog Input Selector

Analog Input Selector of Main system and the Mixing system have the following configuration. Combination is possible for either GND ISO(Diff) or Single-end. Pin 11 to Pin 17 are pins that can be selected for both Main system and a Mixing system, and can be used at the same time. However, combinations Main=GND ISO(Diff)/Mixing=Single-end, and Main=Single-end/Mixing=GND ISO(Diff) cannot be used.

In Mixing system, it is possible to choose L and R and L+R. Therefore, monophonic conversion of the stereo source and simultaneous Mixing of the two monophonic sources are possible.

Analog Input Selector		Main Lch						Main Rch					
		Mixing											
Select Address	Pin Name	INL 1AP	INL 2AN	INL 3BP	INL 4BN	INL 5MP	IN MN	INR 5MP	INR 4BN	INR 3BP	INR 2AN	INR 1AP	
	Pin No. Setting	9	10	11	12	13	14	15	16	17	18	19	
Analog Input Selector 0103(hex) [2:0]	Single1	S1										S1	
	Single2		S2								S2		
	Single3			S3						S3			
	Single4				S4				S4				
	Single5					S5		S5					
	Diff A	AP	AN									AN	AP
	Diff B			BP	BN				BN	BP			
Diff C					CP	CN	CP						
Analog Mixing Input Selector 0103(hex) [6:4]	Single M1			M1						M1			
	Single M2				M2				M2				
	Single M3					M3		M3					
	Single M4						M4						
	Diff MA			MAP	MAN				MAN	MAP			
	Diff MB					MBP	MBN	MBP					

*Pin 11 to Pin 17: Dual Source Selector

Main/Mixing		Analog Mixing Input Selector 0103(hex)[6:4]					
		Single M1	Single M2	Single M3	Single M4	Diff MA	Diff MB
Analog Input Selector 0103(hex) [2:0]	Single1						
	Single2						
	Single3					Prohibited	
	Single4					Prohibited	
	Single5						Prohibited
	Diff A						
	Diff B	Prohibited	Prohibited				
Diff C			Prohibited	Prohibited			

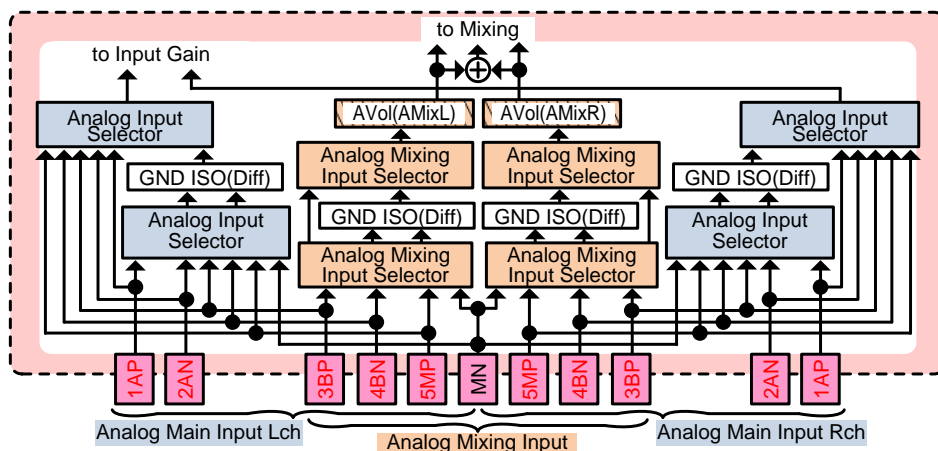
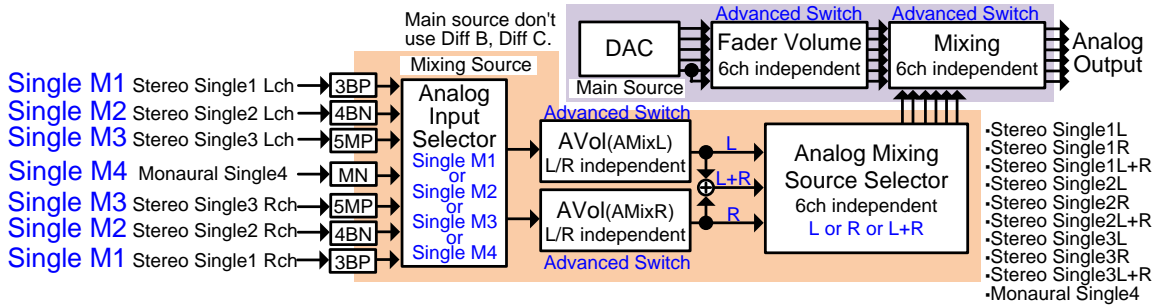

Figure 12. Analog Input Selector Diagram

(6) Analog Mixing Input

Analog Mixing Input is freely possible in GND ISO(Diff)/Single-end. Moreover, the monophonic sources are possible to choose L and R and L+R. Therefore, the two monophonic sources are possible to Mixing.

■ Stereo Single x3, Monaural Single x1



■ Stereo Diff x1, Stereo Single x1, Monaural Single x1 (or Monaural Diff x2, Monaural Single x3)

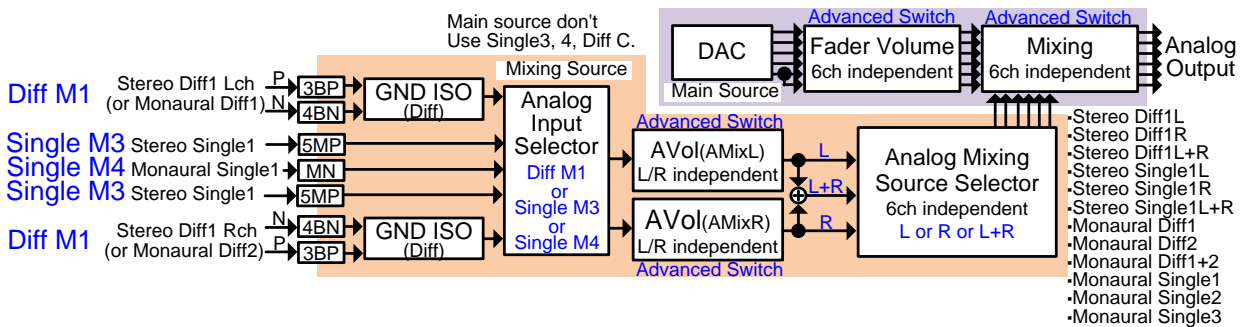

■ Stereo Diff x2 (or Stereo Diff x1, Monaural Diff x2)

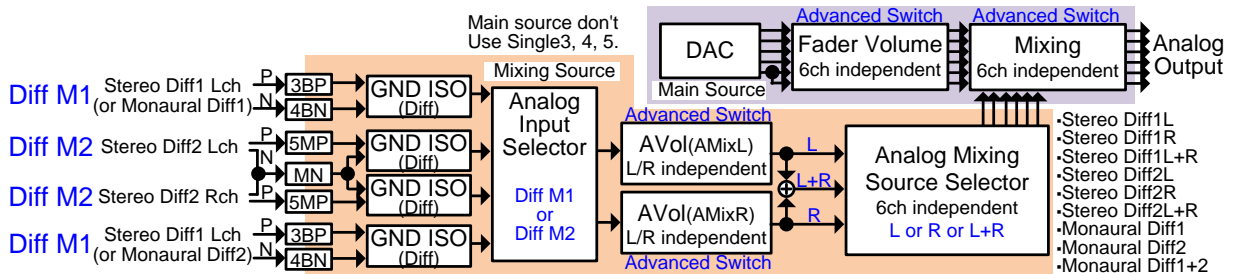

Figure 13. Analog Mixing Input Image Diagram

(7) Digital IO Selector

The combination of input and output can be selected from 4 systems BCK/LRCK from A to D.
 The input/output direction of BCK and LRCK can be selected by Select Address 0010(hex).
 The input/output direction of DIO pins not selected is "Input". Connect unused input pins to DGND.
 When BCK/LRCK Direction of Output1/Output3 is "Input", BCK/LRCK should be synchronized with MCK.
 ExtIO(Output2 & Input2) are set only to 44.1kHz/48kHz which is synchronized with MCK.

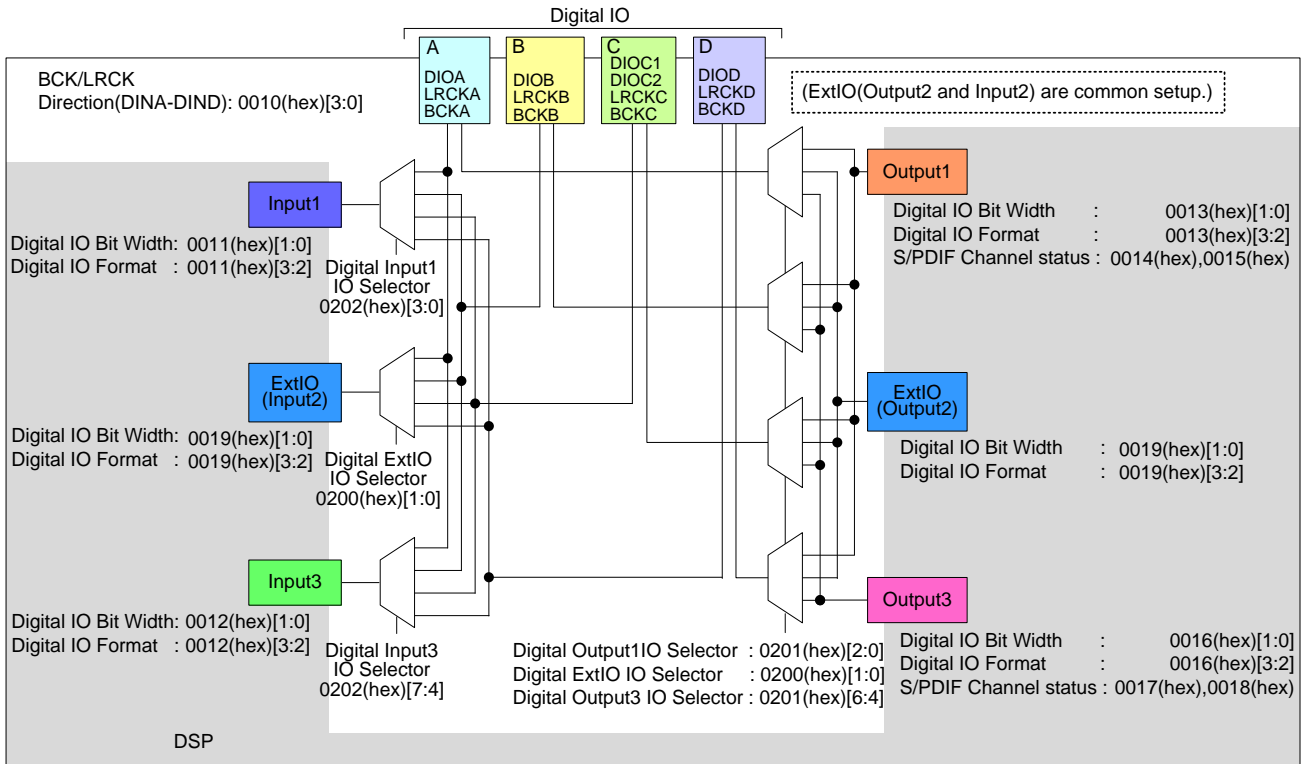

Figure 14. Digital IO Selector Image Diagram

(7)Digital IO Selector - Continued

About settings of each Digital IO Selector, Digital IO and Digital Input pins(Pin 30 to Pin 39, Pin 46 to Pin 49) are assigned as 3 Wires Serial Audio I/F, S/SPDIF Data or BEEP Trigger by the following table.
 Do not assign several pins which have different functions to same Digital IO and Digital Input pins.
 But Input1 and Input3 are possible to use same setting.

Example. Pin Assignment for Digital ExtIO(Output2 & Input2)(0200(hex)[1:0])=B-1
 Pin 30=DINF, Pin 31=DINR, Pin 32=DINS, Pin 33=DOUT, Pin 34=LRCK, Pin 35=BCK

Symbols in the table:
 BCK and LRCK: Pins selected are used as BCK and LRCK of 3 Wires Serial Audio I/F.
 DIN or DINF/R/S: Pins selected are used as DIO(In) of 3 Wires Serial Audio I/F or S/SPDIF Data.
 DOUT or DOUTF/R/S: Pins selected are used as DIO(Out) of 3 Wires Serial Audio I/F or S/SPDIF Data.
 Above "F/R/S" shows "Front L/R", "Rear L/R" or "Sub L/R" respectively.
 BEEP: Pin selected is used as BEEP Trigger of BEEP function.

Digital IO Selector		Pin Assignment Table														BEEP
		Digital IO														
Select Address	Pin Name	A			B			C				D			49	
	Pin No. Setting	DIOA	LRCKA	BCKA	DIOB	LRCKB	BCKB	DIOC2	DIOC1	LRCKC	BCKC	DIOD	LRCKD	BCKD		
BEEP I/F 0010(hex)[5]	Disable															
	Enable														BEEP	
Input1 0202(hex) [3:0]	Disable															
	A-1	DIN	LRCK	BCK												
	B-1				DIN	LRCK	BCK									
	B-2			DIN		LRCK	BCK									
	B-3		DIN			LRCK	BCK									
	B-4	DIN				LRCK	BCK									
	C-1								DIN	LRCK	BCK					
	C-2							DIN		LRCK	BCK					
ExtIO (Output2 & Input2) 0200(hex) [1:0]	Disable															
	C-1						DIN	DOUT	LRCK	BCK						
	B-1	DINF	DINR	DINS	DOUT	LRCK	BCK									
	C-2				DINF	DINR	DINS		DOUT	LRCK	BCK					
	Disable															
	A-1	DIN	LRCK	BCK												
	B-1				DIN	LRCK	BCK									
	B-2			DIN		LRCK	BCK									
Input3 0202(hex) [7:4]	B-3		DIN			LRCK	BCK									
	B-4	DIN				LRCK	BCK									
	C-1							DIN	LRCK	BCK						
	C-2							DIN		LRCK	BCK					
	D-1											DIN	LRCK	BCK		
	Disable															
	A-1	DOUT	LRCK	BCK												
	B-1				DOUT	LRCK	BCK									
Output1 0201(hex) [2:0]	C-1							DOUT	LRCK	BCK						
	D-1											DOUT	LRCK	BCK		
	B-2	DOUTF	DOUFR	DOUFS		LRCK	BCK									
	C-2				DOUTF	DOUFR	DOUFS			LRCK	BCK					
	C-3							DOUTF	DOUFR	LRCK	BCK	DOUTS				
	Disable															
	A-1	DOUT	LRCK	BCK												
	B-1				DOUT	LRCK	BCK									
Output3 0201(hex) [6:4]	C-1							DOUT	LRCK	BCK						
	D-1											DOUT	LRCK	BCK		

(8) Digital IO Format

[S/PDIF]

S/PDIF audio data can be outputted and inputted, using the DIN/DOUT pin chosen by IO Selector(Except for the characteristic of interface. The characteristic of interface is compliant with the [Electrical Characteristic of Digital System](#) ExtIO is incompatible. The S/PDIF is supported in IEC60958-3: consumer applications.

<Input>

The audio data of S/PDIF can be inputted into the pin chosen as DIN of Input1/Input3 in Digital IO Format=S/PDIF (0011(hex)[3:2], 0012(hex)[3:2]). Input data is only for 2ch linear PCM, and does not support other formats. When it is input into SRC, the corresponding sampling frequency is $f_s=16k/24k/32k/44.1k/48k/88.2k/96k$ Hz. The channel status of S/PDIF inputted by Input1/Input3 can be read-out by the Read command. Read-out is possible after $(1/f_s \times 192 \times 2)$ ms($f_s=48k$ Hz: 8ms) has passed since the beginning of audio data.

<Output>

The audio data of S/PDIF can be outputted into the pin chosen as DOUT of Output1/Output3 in Digital IO Format =S/PDIF(0013(hex)[3:2], 0016(hex)[3:2]). Output data is only for 2ch linear PCM, and does not support other formats. It corresponds only to $f_s=44.1k$ Hz/48kHz, and the status of output channel can be set arbitrarily by command. When the condition 1 DOUT(Example. Output 1: A-1) is chosen in IO Selector, "Front" 2ch is set as output and the condition 3 DOUTF/DOUTr/DOUts(Example. Output 1: B-2) is chosen, "Front" 2ch, "Rear" 2ch and "Sub" 2ch are set as output $64f_s$ format. On any conditions, the data corresponding to "Front", "Rear", and "Sub" can be chosen by 0207(hex).

Example. Output1 Format

Digital Output1 IO Selector (0201(hex)[2:0])		Digital IO Format Output1(0013(hex)[3:2])	
Condition	Name	I ² S, Left-Justified, Right-Justified	S/PDIF
A-1	DOUT	Front	Front
	DOUTF	Front	Front
B-2	DOUTr	Rear	Rear
	DOUts	Sub	Sub

(9) Digital ExtIO(Digital Input2/Digital Output2)

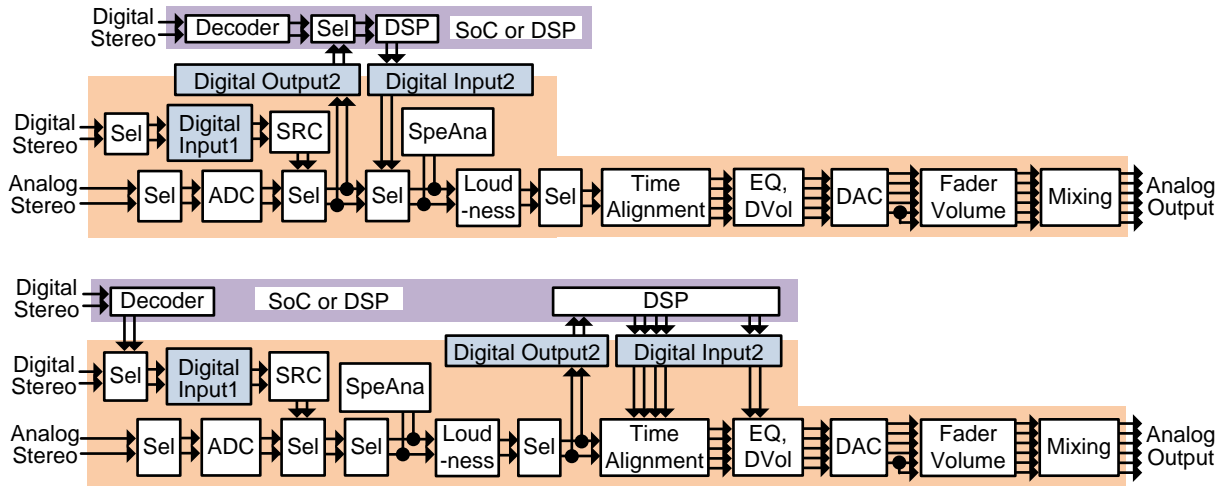

Figure 15. Extended DSP Mode Image Diagram

ExtIO(Digital Input2/Digital Output2) can also be used as an input/output pin of external DSP.

Data format can be in I^S method, Left-Justified method or Right-Justified method. Also, input(or output) can be in 16bit, 20bit or 24bit. Digital Input1 are SRC correspondences and their f_S can be in 8k/16k/24k/32k/44.1k/48k/88.2k/96kHz. The S/PDIF input is also supported in f_S=16k/24k/32k/44.1k/48k/88.2k/96kHz. ExtIO(Output2 & Input2) are set only to 44.1kHz/48kHz which is synchronized with MCK.

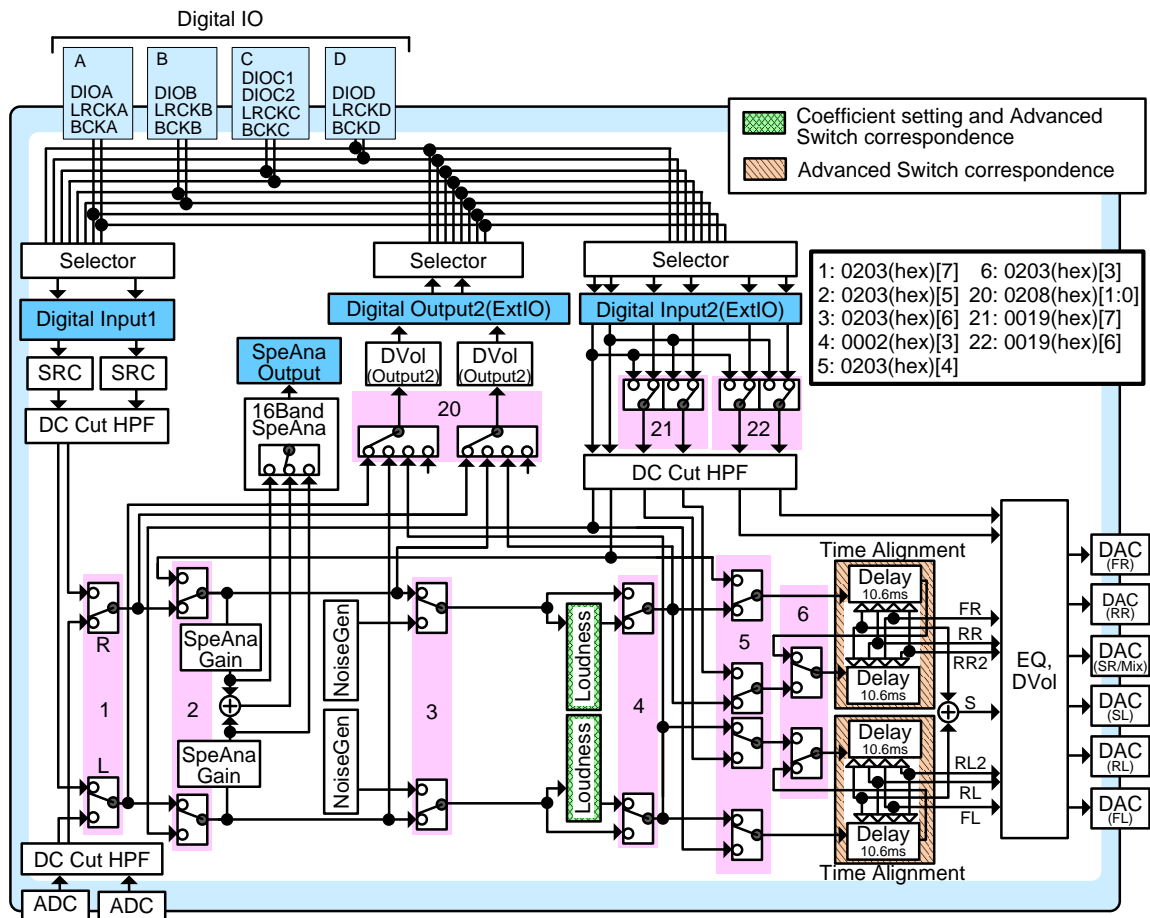

Figure 16. ExtIO Diagram

(10) Time Alignment Mode

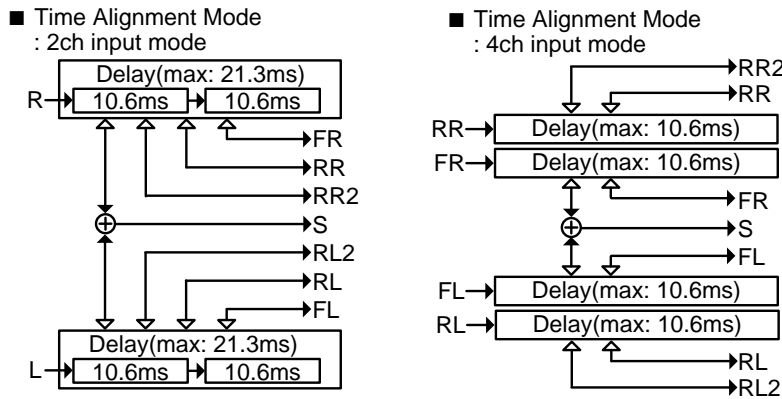

Figure 17. Time Alignment Mode Image Diagram

S is the Mixing system from the Time Alignment of FL and FR, and Time Alignment value can be setup independently from FL and FR.

- 21.3ms($f_s=48\text{kHz}$) or 23.0ms($f_s=44.1\text{kHz}$) is maximum in 2ch-input Mode. Setting data is: 3FF(hex)
- 10.6ms($f_s=48\text{kHz}$) or 11.5ms($f_s=44.1\text{kHz}$) is maximum in 4ch-input Mode. Setting data is: 1FF(hex)
(Data from 200(hex) to 3FF(hex) is prohibited.)

The input signal level to the Time Alignment circuit must be 0dBFS or less. When the signal is bigger, a waveform is clipped at a Time Alignment circuit. And it is not able to recover from clipping by the volumes after the Time Alignment circuit(DVol, Fader Volume).

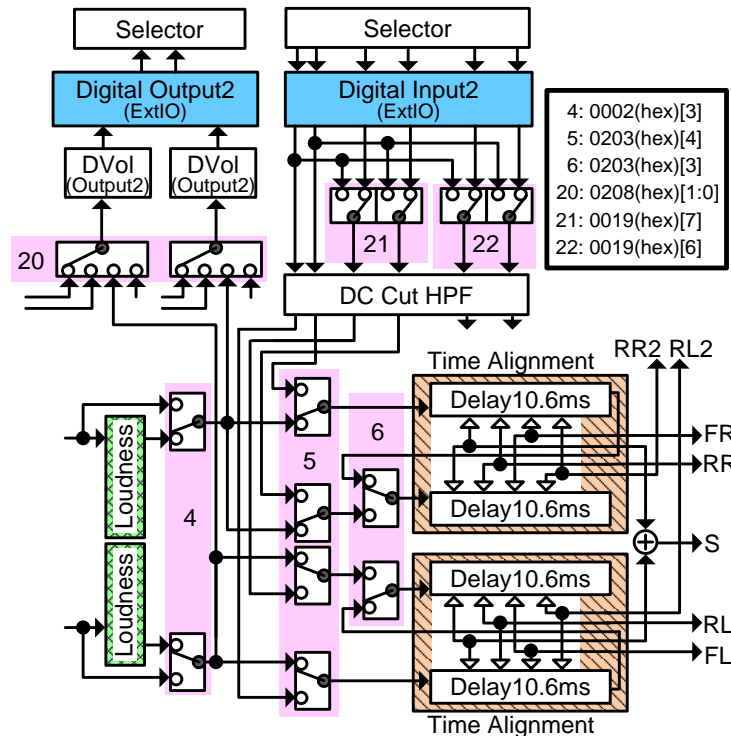
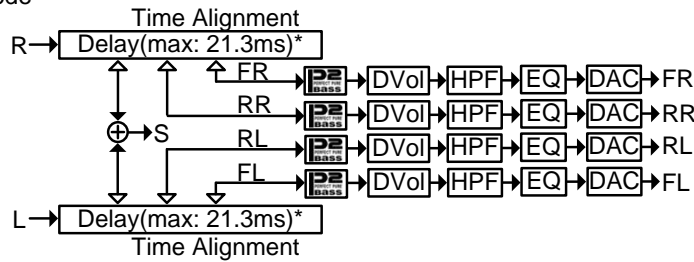

Figure 18. Time Alignment Mode Diagram

(11) Surround Mode

Surround Mode consists of IIR A, IIR B, Time Alignment RL2, and RR2 blocks. RL2 and RR2 are the systems to which the Delay of RL and RR branch and Delay value can be setup independently from RL and RR. Arbitrary filters are configured by specifying directly the coefficient of an IIR filter.

■ Initial Mode



■ Surround Mode

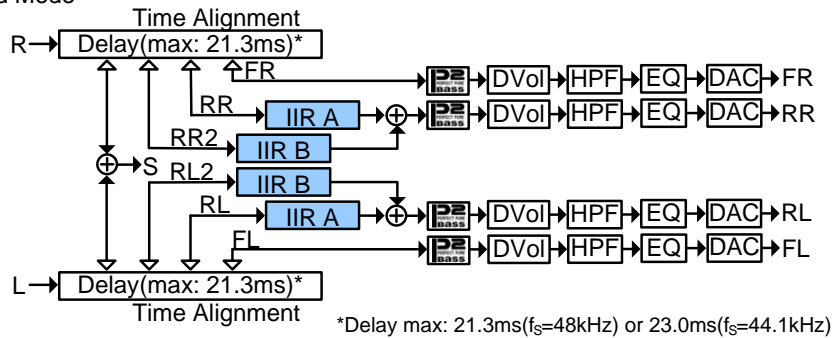

*Delay max: 21.3ms($f_s=48\text{kHz}$) or 23.0ms($f_s=44.1\text{kHz}$)

Figure 19. Surround Mode Image Diagram

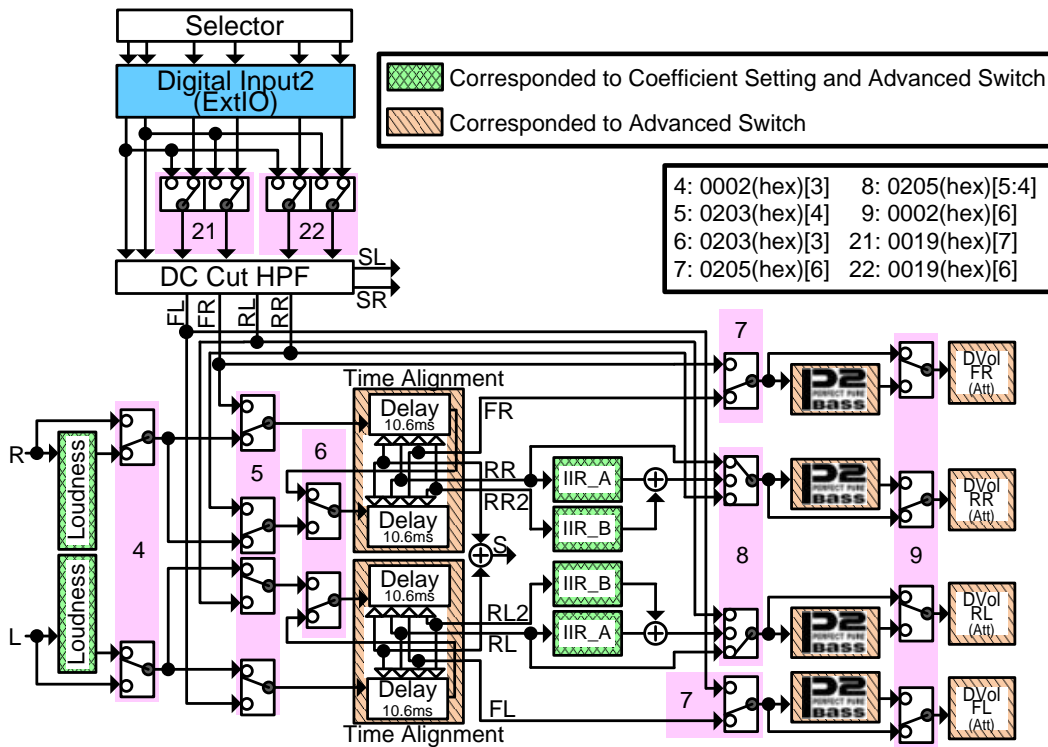

Figure 20. Surround Mode Diagram

(12) Filter Coefficient Direct Setup

[13-Band EQ, 3-Band Tone(EQ), Front/Rear HPF, IIR A/B(Surround), Sub HPF/LPF/IIR, Loudness HPF/LPF]

Each band is configured by 2nd order IIR filter and the coefficients can be specified directly to make arbitrary filter. In the case of using coefficient direct setting, confirm the characteristics and transient response of the filter.

Each filter block is a cascade connection of 2nd order IIR filter.

The coefficients can be set by writing all coefficients b0, b1, b2, a1 and a2 to Coef registers after choosing a filter by Coef Selector register. After least significant byte of a2 is written, the coefficients are transmitted into internal RAM.

In case a filter with Advanced Switch is used, change of coefficients is reflected by soft transition.

When the coefficients of 2 or more bands are changed, soft transition is performed sequentially, because there is only one Advanced Switch circuit on each channel.

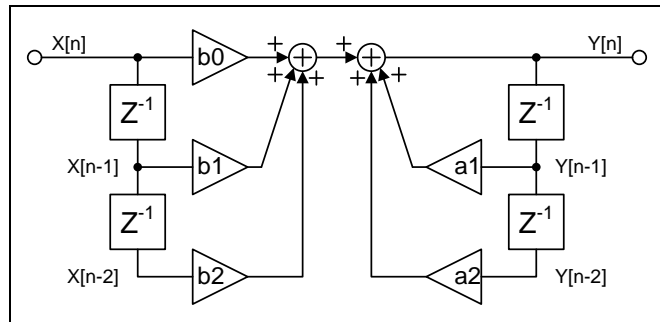

Figure 21. 2nd Order IIR Filter

The data formats of coefficients(b0, b1, b2, a1 and a2) for 2nd IIR filter are as follows.

Filter Block	Bit Width	Fixed-point Format	Range
13-Band EQ, 3-Band Tone(EQ) Front/Rear HPF IIR(A/B)(Surround) Sub HPF/LPF/IIR	32bits	S4.27 (1 sign bit and 4 integer bits and 27 decimal bits)	-16 ≤ Values < +16
Loudness HPF/LPF	24bits	S2.21 (1 sign bit and 2 integer bits and 21 decimal bits)	-4 ≤ Values < +4

The coefficients of each filter can be set by the following registers.

Filter Block	Coef Selector	Coef Read back Setting	Coef
13-Band EQ, 3-Band Tone(EQ)	1000(hex)	1500(hex)	1001(hex) to 1014(hex)
(Front/Rear)HPF(A/B) IIR(A/B)(Surround)	1100(hex)	1501(hex)	1101(hex) to 1114(hex)
Loudness HPF/LPF	1200(hex)		1201(hex) to 120F(hex)
Sub HPF/LPF/IIR	1300(hex)		1301(hex) to 1314(hex)

<The sequence to write coefficients>

1. Set Direct Coef Set(061F(hex)[7])=Coef.
2. Choose a filter and a channel by a Coef Selector register.
3. Write all 5 coefficients(b0, b1, b2, a1 and a2) into Coef registers. (Auto increment function is available)
After writing least significant byte of a2, the coefficients are automatically transmitted into internal RAM.

<The sequence to read coefficients>

1. Set Direct Coef Set(061F(hex)[7])=Coef.
2. Choose a filter and a channel by a Coef Read back Setting register.
3. Read Coef IO Status(A053(hex)[3:0]) repeatedly, until it will be "0"(Done). ("1"(Busy) during writing)
4. Read all 5 coefficients from most significant byte of b0. (Auto increment function is available)

(12) Filter Coefficient Direct Setup - Continued

[13-Band EQ and 3-Band Tone(EQ)]

13-Band EQ and 3-Band Tone(EQ) filters are connected in order from high frequency f_0 or f_c to low frequency f_0 or f_c . Each band is configured by 2nd order IIR filter. (Refer to Figure 21.)

It is recommended that the order of filter is same as table Mode(from high frequency to low frequency) even when direct coefficients setting Mode is used.

In Table Mode, the coefficients of Front and Rear are common for L and R channels.

In direct coefficients setting Mode, the coefficients can be set independently.

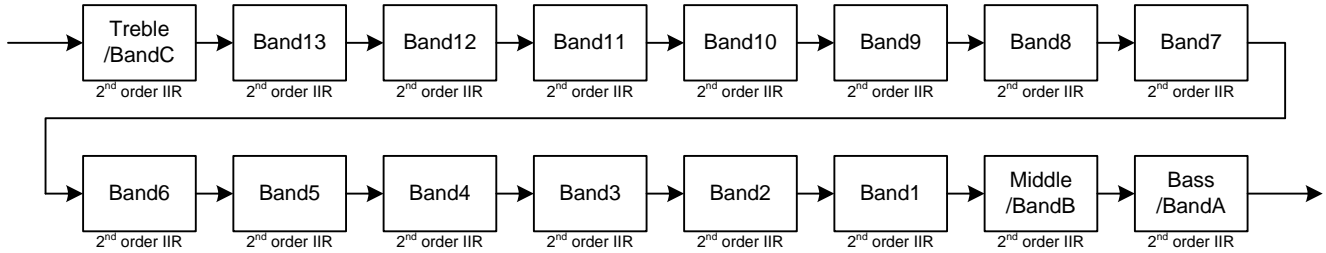

Figure 22. 13-Band EQ and 3-Band Tone(EQ) Filters

[Front/Rear HPF]

Front/Rear HPF is cascade connection of two 2nd order IIR filters.

In Table Mode, the filter can be used as 2nd or 4th order HPF.

In direct coefficients setting Mode, coefficients of HPF A and HPF B can be set independently.

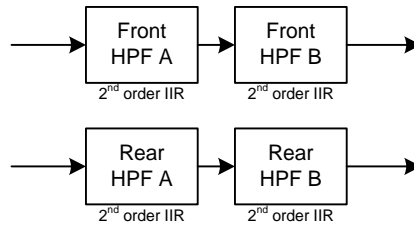

Figure 23. Front/Rear HPF

[IIR A/B(Surround)]

IIR A and IIR B are configured by 2nd order IIR filter. (Refer to Figure 21.)

(12) Filter Coefficient Direct Setup - Continued

[Loudness]

Loudness circuit consists of a LPF, HPF and gain circuit.

Each LPF and HPF is a 2nd order IIR filter and those coefficients can be specified directly to make an arbitrary filter.

At this time, the coefficients of HPF and LPF will reflect the changes made, while the gain coefficient will change through soft transition. The values of the 5 coefficients of HPF/LPF can be -4 or more and less than +4. Data format of HPF/LPF is 24bits fixed-point number "S2.21". S2.21 represents a number with 1 sign bit and 2 integer bits and 21 decimal bits.

The values of coefficients of HiBoost/Gain can be -2 or more and less than +2. Data format of HiBoost/Gain is 16bits fixed-point number "S1.14". S1.14 represents a number with 1 sign bit and 1 integer bit and 14 decimal bits.

The output level of Loudness must be 0dBFS or less. If the output is over 0dBFS, clipping occurs at the next Time Alignment circuit. In this case, the next Volume(DVVol and Fader Volume) after the Delay circuit cannot recover the clipping.

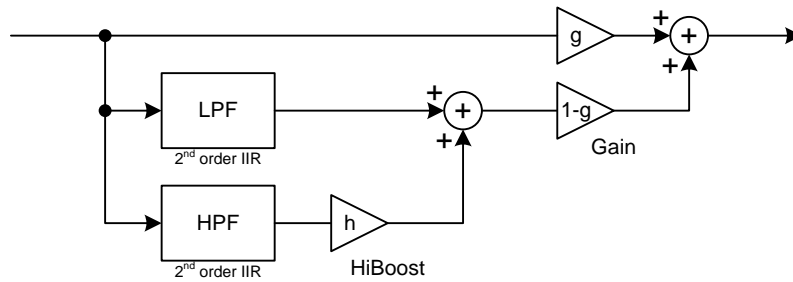

Figure 24. Loudness

[Sub HPF/LPF/IIR]

Sub HPF and LPF are cascade connections of two 2nd order IIR filters.

In Table Mode, the filter can be used as 2nd or 4th order HPF/LPF.

Sub IIR is configured by 2nd order IIR filter.

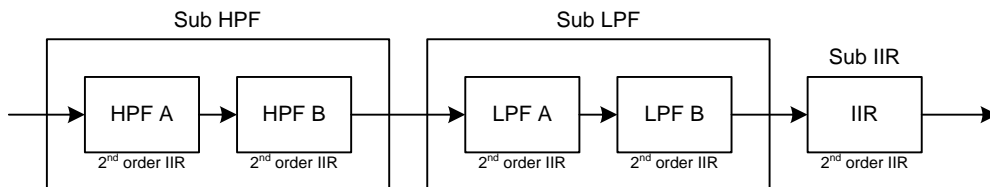
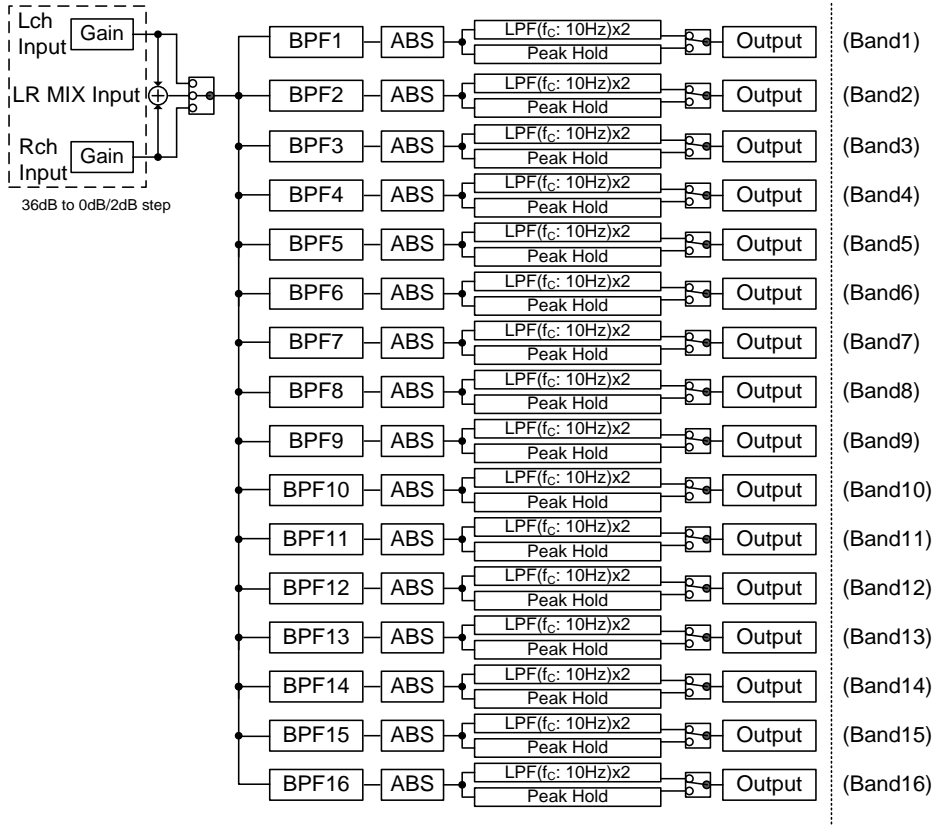

Figure 25. Sub HPF/LPF/IIR

(13) Spectrum Analyzer

- Input level can be adjusted in 2dB steps from 0dB to 36dB. Available operation modes are Averaging Mode, Peak Hold Mode, Level Meter Mode and Signal Through Mode.
- With Averaging Mode, the value after LPF of each band in read-out timing is outputted.
- With Peak Hold Mode, the peak hold value of each band in read-out timing is outputted, and the peak value is reset.
- With Level Meter Mode, the Peak Hold value for 3 bands of Lch/Rch/LRmix is outputted bypassing the BPF, and the peak value is reset. Band1/Band2/Band3 carries out fixed operation to LRmix/Lch/Rch, respectively. In Signal Through Mode, ABS and peak hold circuits are bypassed.

Averaging Mode / Peak Hold Mode



Level Meter (with ABS & Peak Hold) / Signal Through (bypass ABS & Peak Hold) Mode

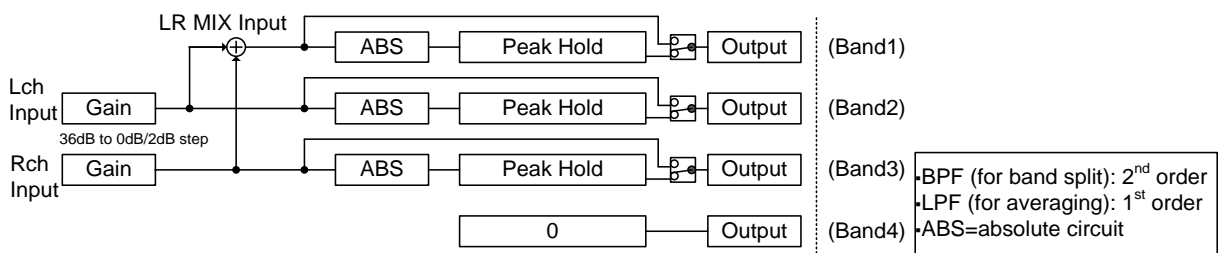

Figure 26. Spectrum Analyzer Diagram

“f₀” of each band is as follows.

16-Band

Band	1	2	3	4	5	6	7	8	9	10	11	12	13	14	15	16
f ₀ [Hz]	20	31.5	50	80	125	200	315	500	800	1.25k	2k	3.15k	5k	8k	12.5k	20k

Spectrum Analyzer output value is read from “Spectrum Analyzer Status” (Select Address(A000(hex) to A01F(hex))). The output value is the fixed-point number format of “S0.15” (A 16bits sign, 15bits of decimal sections).

(14) BEEP

BEEP output waveform can be chosen from sine wave or rectangular wave. The output level, frequency, ON/OFF time and the number of repetitions for BEEP can be setup. Operation Mode also can be chosen from Auto or Manual. Fade-In/Out function(1ms fixed) when output ON/OFF can also be selected.

[Auto Mode]: BEEP Mode(0801(hex)[7])=Auto

By BEEP Trigger(0803(hex)[0])=start(ON), BEEP is repeatedly set ON/OFF for a set number of times. BEEP is outputted every time BEEP Trigger=Start is received. It doesn't need to set BEEP Trigger=Normal to make BEEP out again. Trigger operation interruption during output operation is possible and output operation is restarted by the newest set received when the completion of output operation.

[Manual Mode]: BEEP Mode(0801(hex)[7])=Manual

The manual Mode ON/OFF of a BEEP is performed by setting up BEEP Trigger(0803(hex)[0])=Start(ON)/Normal(OFF) directly. ON/OFF time depends on the transmission time of the Trigger command. The transmission side needs to be adjusted. The setup frequency by the Trigger Command ON is output continuously.

Moreover, if BEEP I/F(0010(hex)[5])=Enable is setup in the Mode of each Manual/Auto, BEEP Trigger ON/OFF control can be performed by directly connecting the H/L input to Pin 49.

(H input over 4 audio cycles: Start(ON), L input over 4 audio cycles: Normal(OFF).)

Since a BEEP is outputted under the setup when ON control start, it is possible to change the setting during output operation, but a BEEP setting is not created until the next ON control.

An audio cycle means the time of $1/f_s$. 4 audio cycle= $4/48\text{kHz}=83.3\mu\text{s}$ ($f_s=48\text{kHz}$)

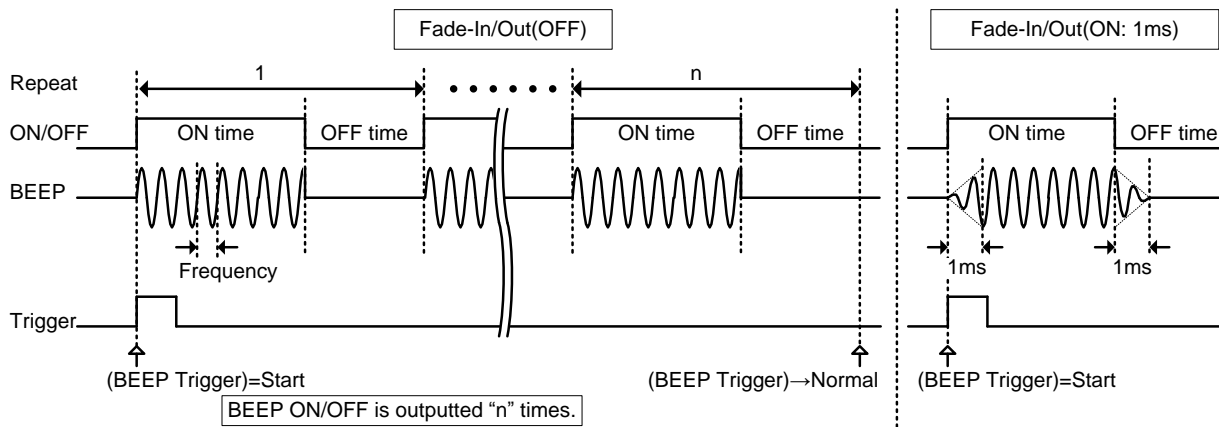

Figure 27. BEEP Operation

(14) BEEP - Continued

[Coefficient Direct Setup of BEEP]

The output frequency and ON/OFF time(when Auto Mode) of BEEP can also be setup directly by the coefficient.

• Output Frequency

Output frequency is setup by Sine Wave Coef b1 and a1(1400(hex) to 1405(hex)). The coefficient, "b1 and a1" are the fixed-point number format of "S1.22" (1 sign bit and 1 integer bit and 22 decimal bits)

Sine Wave Coef

$$b1 = \sin(2 \times \pi \times (f_{out}/f_s)), a1 = 2 \times \cos(2 \times \pi \times (f_{out}/f_s)) \dots f_{out}: \text{Output frequency}(20\text{Hz to } 20\text{kHz})$$

Example. $f_{out} = 1\text{kHz}, f_s = 44.1\text{kHz}$

$$b1 = \sin(2 \times \pi \times (1\text{k}/44.1\text{k})) = 0.141994318 = 09166Fh$$

$$a1 = 2 \times \cos(2 \times \pi \times (1\text{k}/44.1\text{k})) = 1.979734946 = 7EB3FAh$$

• ON/OFF Time

Set "ON/OFF Time" at set ON/OFF Time Coef(1406(hex) to 140B(hex)). Coefs are 18bit integers

ON/OFF Time Coef

$$ON/OFF_time_threshold = set_time \times f_s - 2 \dots set_time: \text{Setting time [s]}$$

Example. $set_time = 600\text{ms}, f_s = 44.1\text{kHz}$

$$ON/OFF_time_threshold = 0.6 \times 44100 - 2 = 26458 = 0675Ah$$

[Rectangular Wave]

After boosting "Sine wave" by 6dB, the wave clipped by 0dBFS is outputted as "Rectangular wave". BEEP Level setup becomes effective to "The wave clipped by 0dBFS". Rectangular wave is broken with over than BEEP Frequency=4kHz. Use with care about the characteristics.

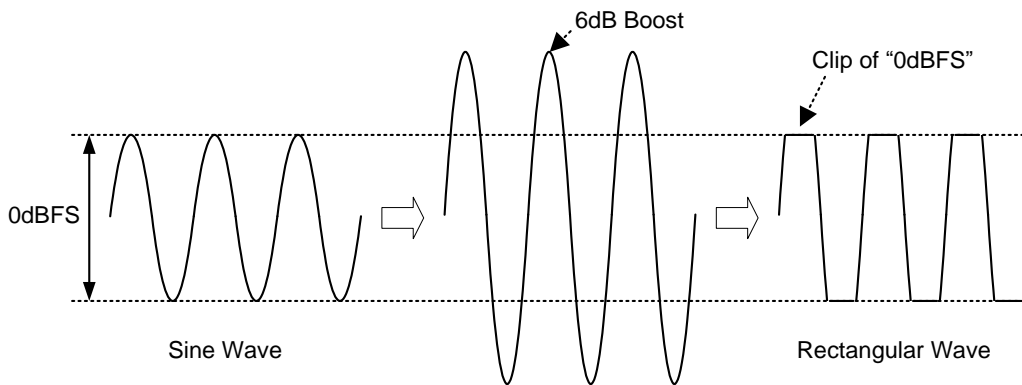

Figure 28. Rectangle Wave Generation

(15) Fader Volume Advanced Switch

Advanced Switch is ROHM’s original pop noise prevention technology which prevents discontinuous waveforms by gradually changing the signal level.

Advanced Switch time for Fader Volume can be changed with respect to the value of Fader volume. “Fader Volume Threshold Gain(off, -4dB to -18dB)” can be set in Select Address 0005(hex)[7:4], and “Advanced Switch time for Fader Volume upper Gain” can be set in 0005(hex)[3:0]. When “Fader Volume threshold gain” is off or the switching gain is less than “Fader Volume threshold gain”, Advanced Switch time is set in Select Address 0003(hex)[2:0]. Outline image of “Advanced Switch time for Fader Volume” is below.

(Prohibitions)

Do not send Mixing ON/OFF data(0106(hex)[5:0], 0109(hex)[5:0]) during same channel Fader Volume Advanced Switch operation. Pop noise may occur.

Do not send Fader Volume Gain setting data(0A00(hex) to 0A05(hex)[6:0]) during same channel Mixing/Mixing Fader Advanced Switch operation. Fader Volume may malfunction.

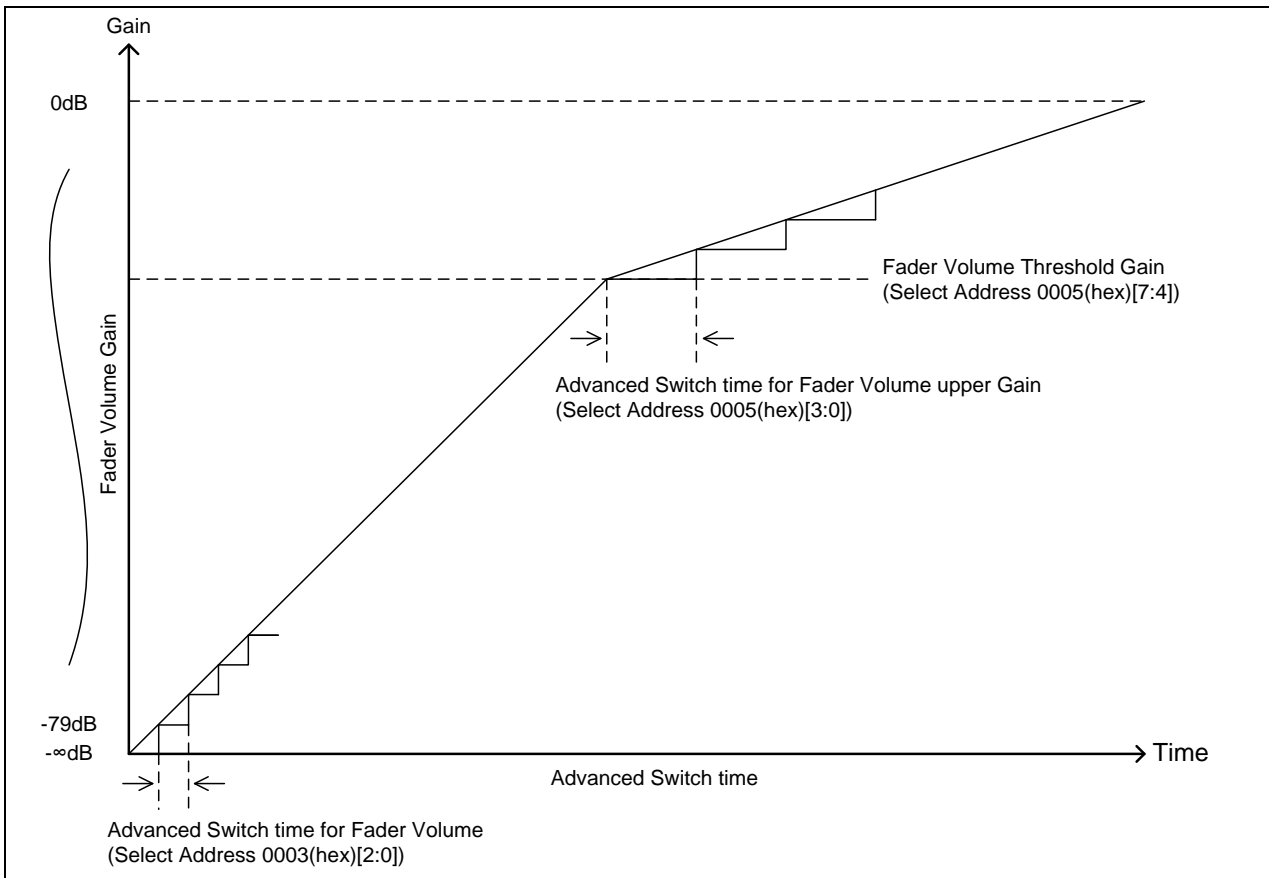

Figure 29. Outline image of Advanced Switch time for Fader Volume(-∞dB to 0dB)

(15) Fader Volume Advanced Switch - Continued

<Fader Volume>

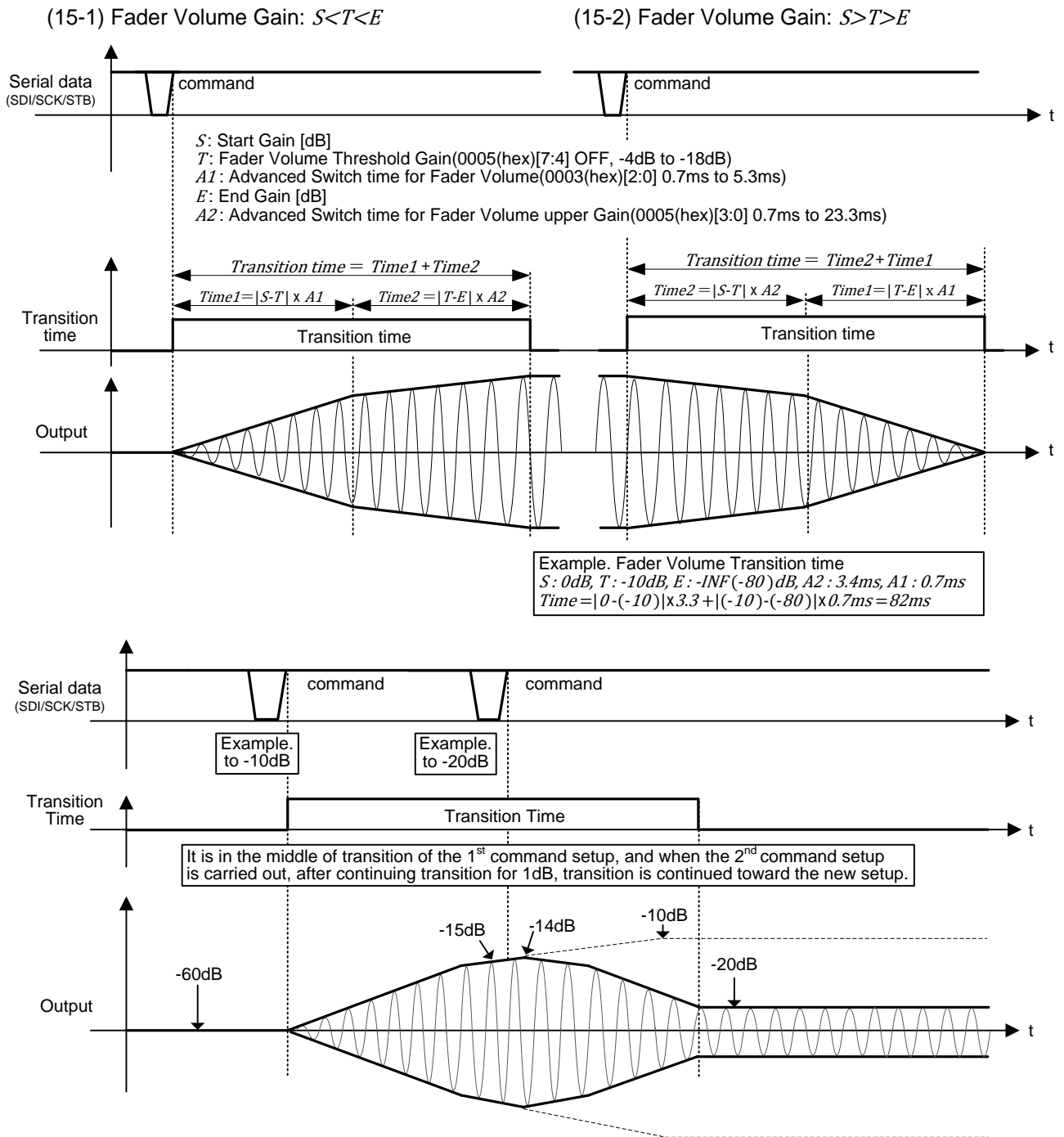

Figure 30. Fader Volume Advanced Switch1

(Prohibitions)

- Do not send Mixing ON/OFF data(0106(hex)[5:0], 0109(hex)[5:0]), Advanced Switch time for Fader Volume data (0003(hex)[2:0]) and Advanced Switch time for Fader Volume upper Gain data(0005(hex)[3:0]), during same channel Fader Volume Advanced Switch Transition time.
- Do not send Fader Volume Gain setting data(0A00(hex) to 0A05(hex)[6:0]) during same channel Mixing/Mixing Fader Advanced Switch operation. Fader Volume may malfunction.

(15) Fader Volume Advanced Switch - Continued

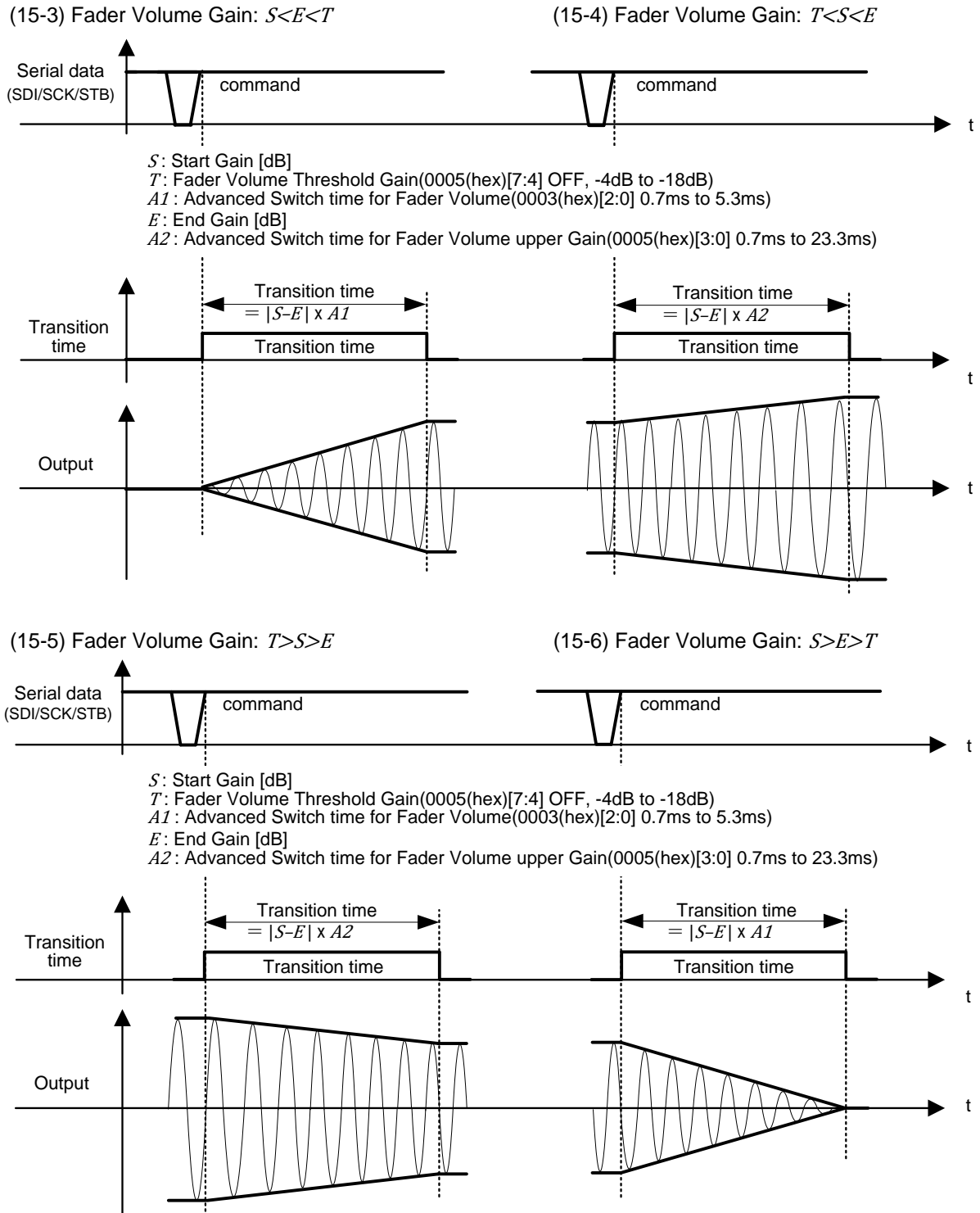

Figure 31. Fader Volume Advanced Switch2

(Prohibitions)

- Do not send Mixing ON/OFF data(0106(hex)[5:0], 0109(hex)[5:0]), Advanced Switch time for Fader Volume data (0003(hex)[2:0]) and Advanced Switch time for Fader Volume upper Gain data(0005(hex)[3:0]), during same channel Fader Volume Advanced Switch Transition time.
- Do not send Fader Volume Gain setting data(0A00(hex) to 0A05(hex)[6:0]) during same channel Mixing/Mixing Fader Advanced Switch operation. Fader Volume may malfunction.

(16) Mixing Advanced Switch

Outline image of Advanced Switch of Mixing ON/OFF is below.

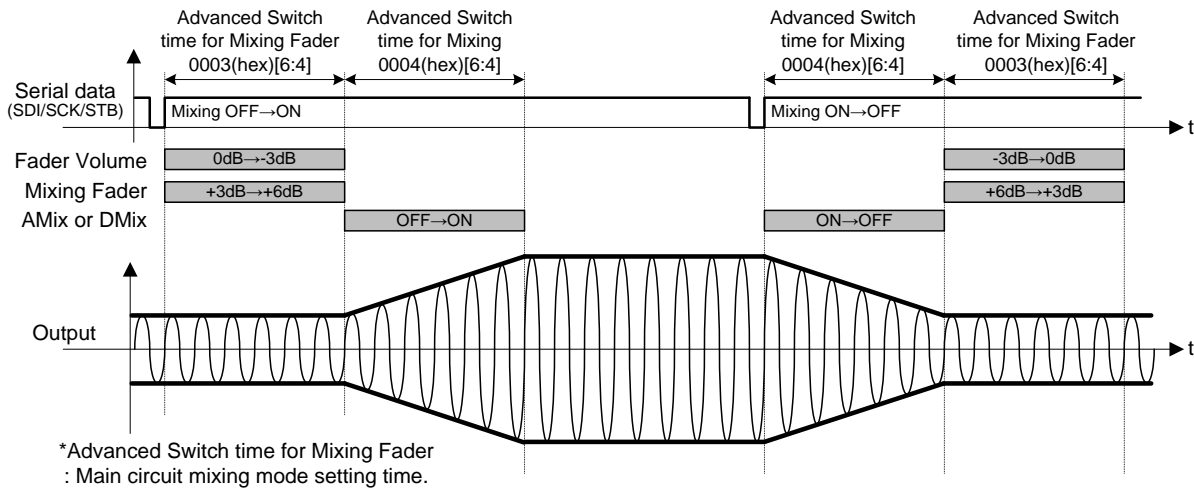

Figure 32. The Mixing ON/OFF change of Fader Volume=0dB

The total switching time of Mixing ON/OFF is set to “(Advanced Switch time for Mixing(0004(hex)[6:4])) + (Advanced Switch time for Mixing Fader(0003(hex)[6:4]))” Moreover, operation of an Advanced Switch when AMix and DMix turn ON/OFF simultaneously is shown below. When the change command of AMix and DMix is transmitted almost simultaneous by the auto increment etc., AMix and DMix do not operate simultaneously but operate one by one in order of DMix after AMix.

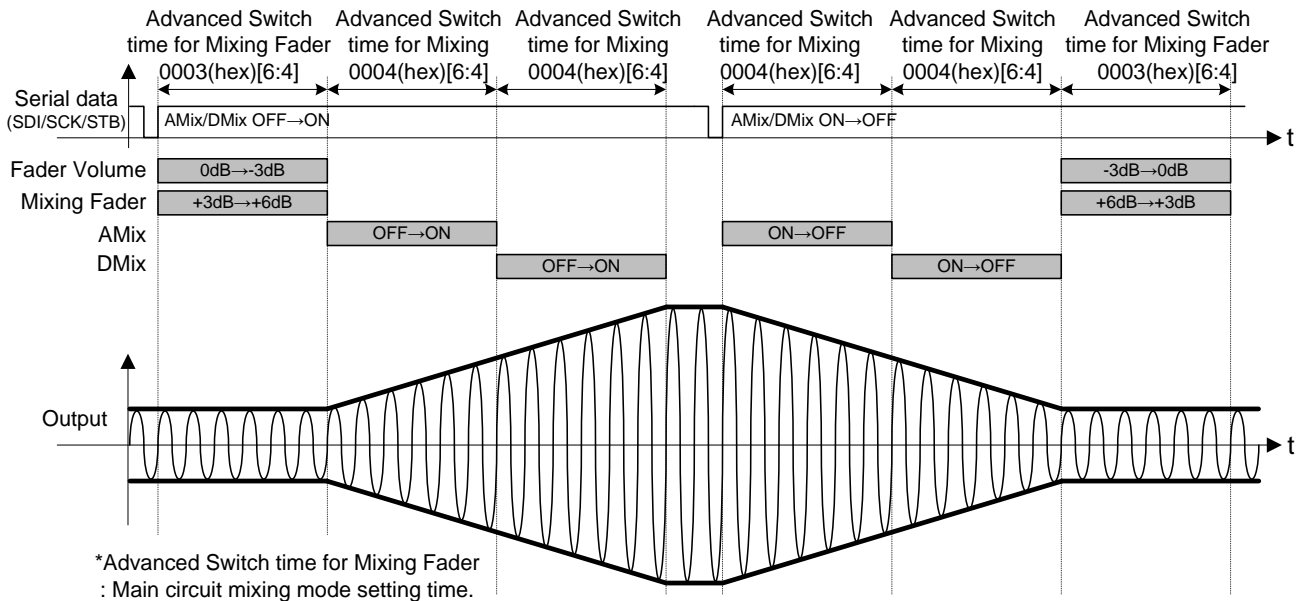

Figure 33. The Mixing ON/OFF change when simultaneous ON/OFF of AMix and DMix

(Prohibitions)

- Do not send Fader Volume Gain setting data(0A00(hex) to 0A05(hex)[6:0]) during same channel Mixing/Mixing Fader Advanced Switch operation. Fader Volume may malfunction.
- Do not send Mixing ON/OFF data(0106(hex)[5:0], 0109(hex)[5:0]) during same channel Fader Volume Advanced Switch operation. Pop noise may occur.

(Mute)

- Mute use DVol(Att)=-∞dB. In addition, use Fader Volume= -∞dB when it is necessary to lower the noise level.

(16) Mixing Advanced Switch - Continued

<Mixing ON/OFF>

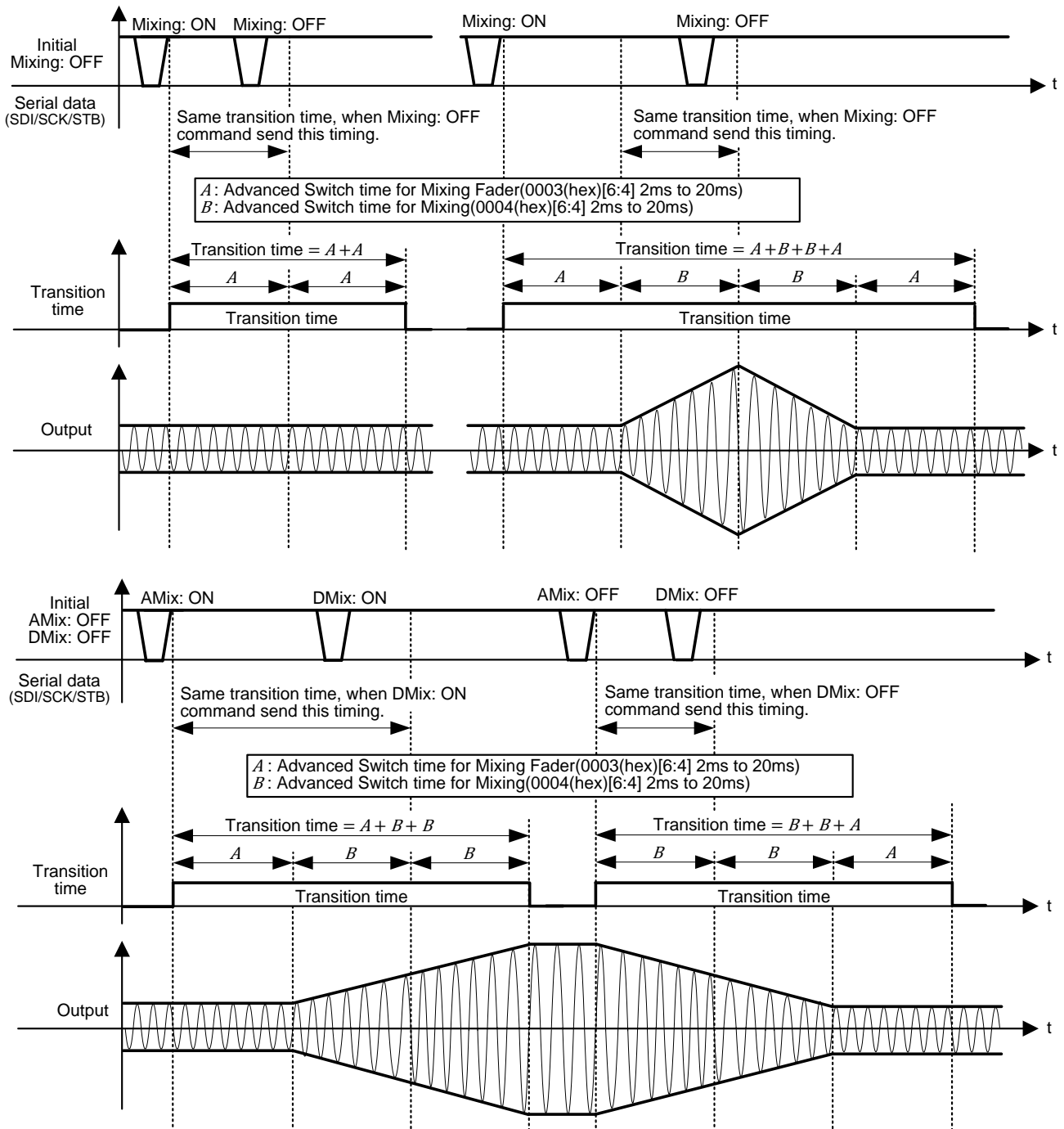

Figure 34. Mixing Advanced Switch1

(Prohibitions)

- Do not send Mixing ON/OFF data(0106(hex)[5:0], 0109(hex)[5:0]) during same channel Fader Volume Advanced Switch operation. Pop noise may occur.
- Do not send Fader Volume Gain setting data(0A00(hex) to 0A05(hex)[6:0]), Advanced Switch time for Mixing Fader data (0003(hex)[6:4]) and Advanced Switch time for Mixing data(0004(hex)[6:4]), during same channel Mixing/Mixing Fader Advanced Switch Transition time.

(16) Mixing Advanced Switch - Continued

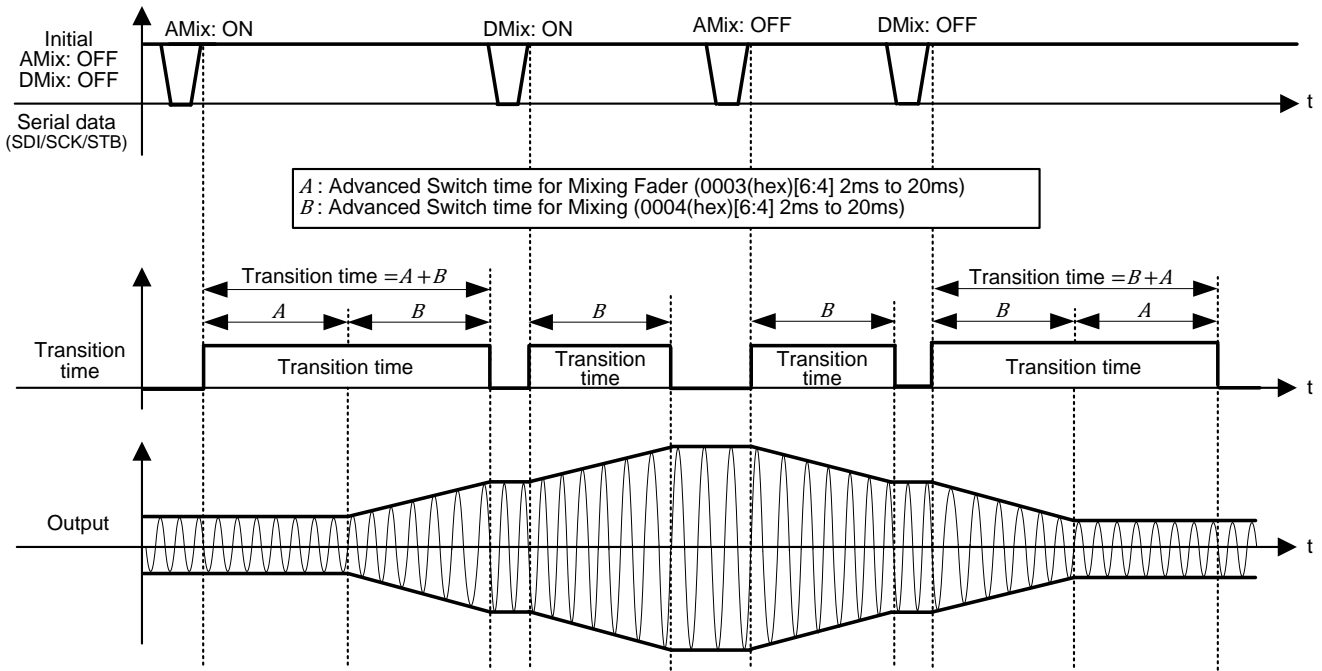

Figure 35. Mixing Advanced Switch2

(Prohibitions)

- Do not send Mixing ON/OFF data(0106(hex)[5:0], 0109(hex)[5:0]) during same channel Fader Volume Advanced Switch operation. Pop noise may occur.
- Do not send Fader Volume Gain setting data(0A00(hex) to 0A05(hex)[6:0]), Advanced Switch time for Mixing Fader data (0003(hex)[6:4]) and Advanced Switch time for Mixing data(0004(hex)[6:4]), during same channel Mixing/Mixing Fader Advanced Switch Transition time.

(17) Advanced Switch(Other than Fader Volume and Mixing)

Advanced Switching is different between each function. See below.

<AVol(AMix/DMix)>

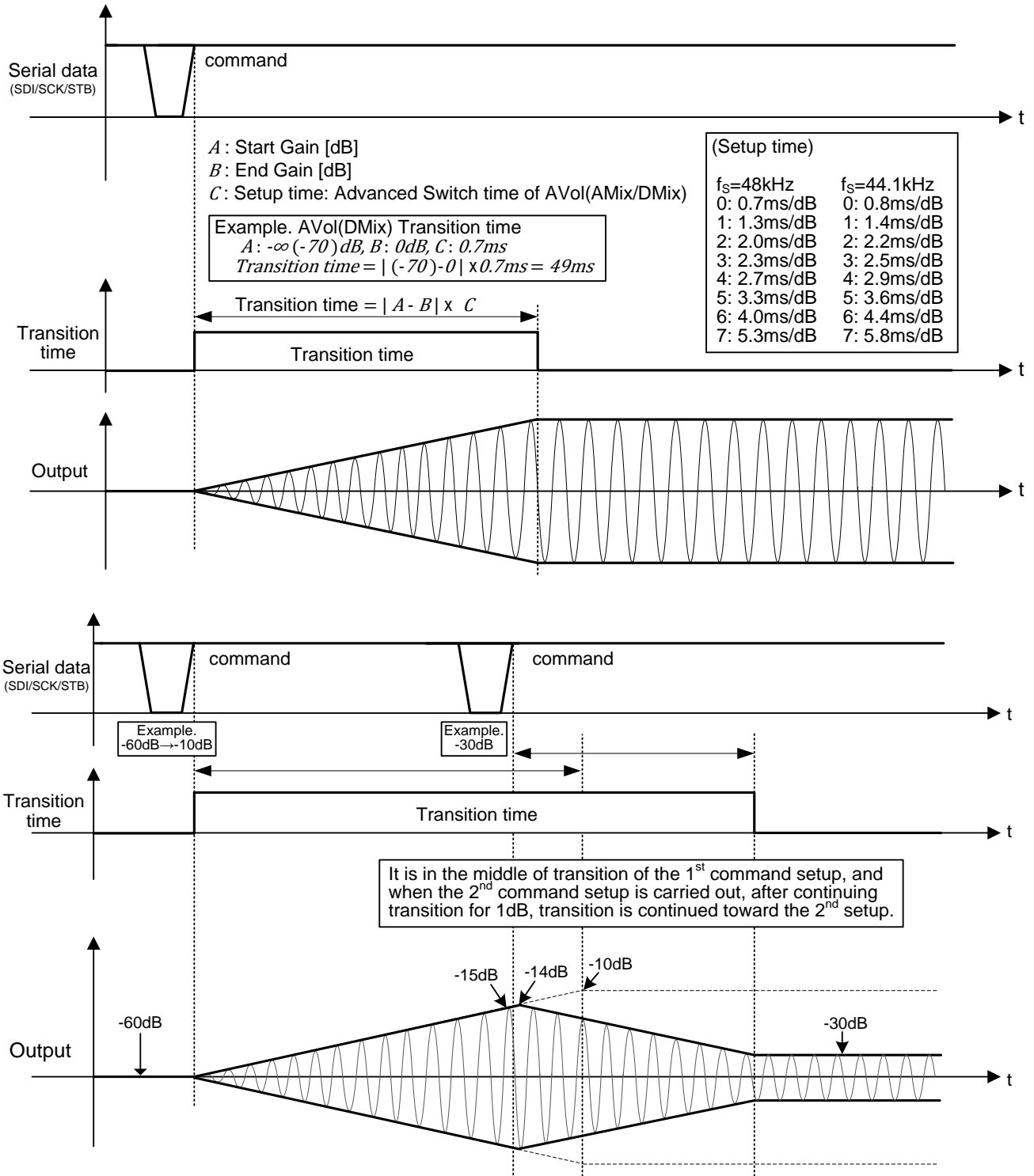

Figure 36. AVol(AMix/DMix) Advanced Switch

(17) Advanced Switch(Other than Fader Volume and Mixing) - Continued

<DSP Gain(DVol(Att, Boost), P²Bass Gain, Loudness Gain)>

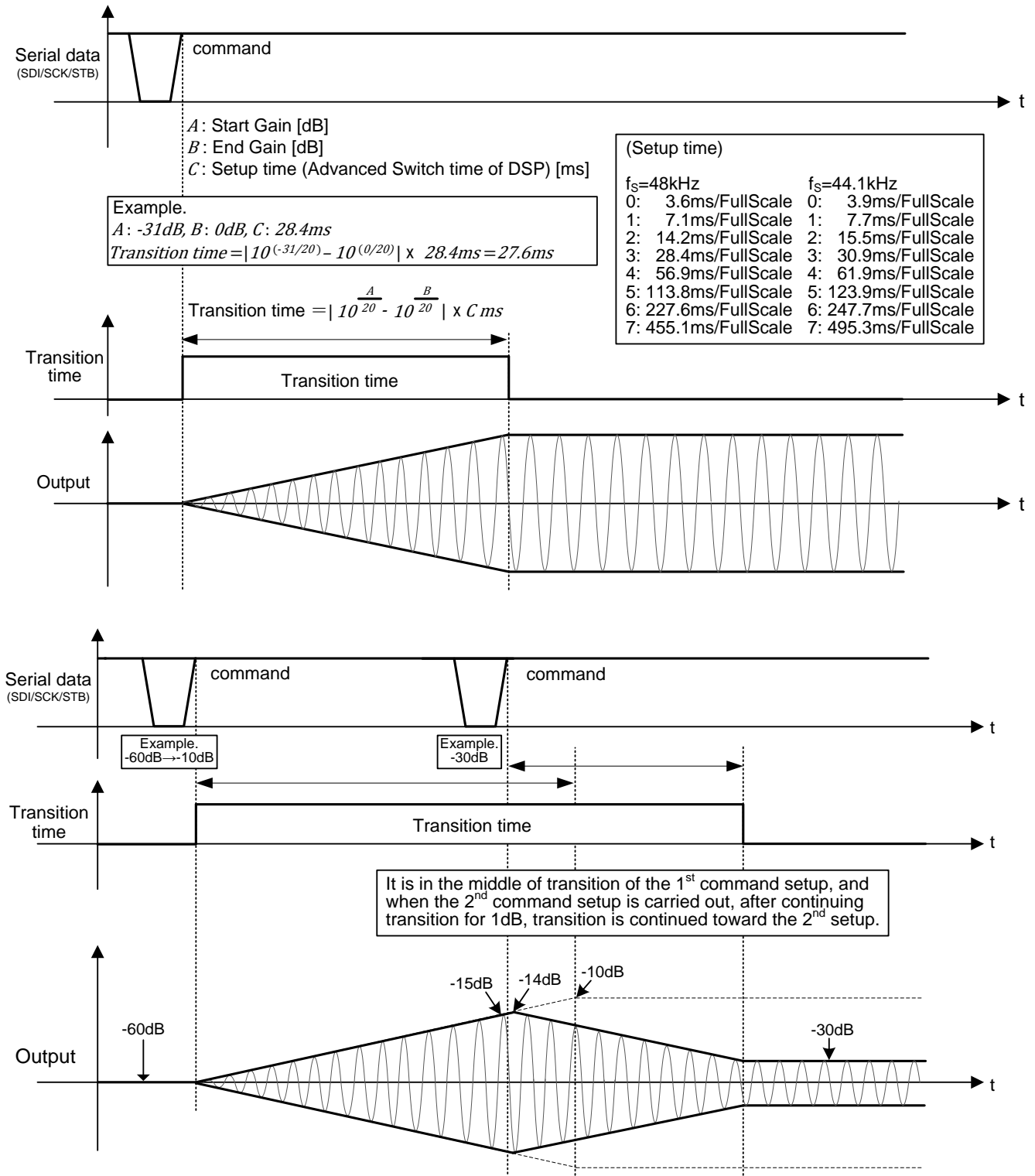

Figure 37. DVol Advanced Switch

(Mute)

Mute use DVol(Att)=-∞dB. In addition, use Fader Volume=-∞dB when it is necessary to lower the noise level.

(17) Advanced Switch(Other than Fader Volume and Mixing) - Continued

<DSP Filter(13-Band EQ, 3-Band Tone, HPF(Coef), IIR A, IIR B)>

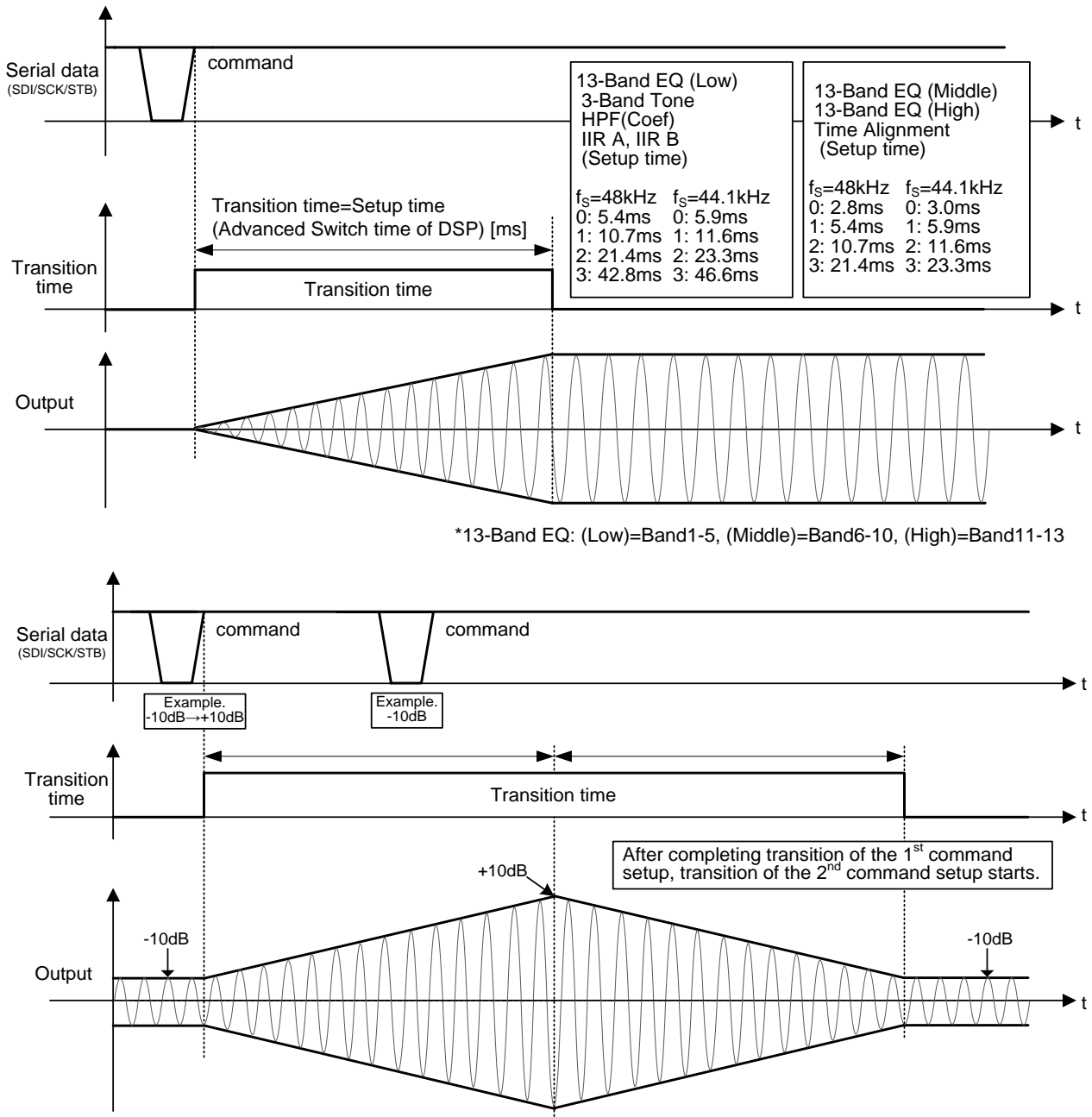

Figure 38. DSP Filter Advanced Switch

Advanced Switch of PEQ, 2nd IIR is executed for a filter per 1ch, if some filters are changed at same time. Transition time is Setup time of Advanced Switch time(0007(hex)[7:0]) x numbers of changed filters. But it is not always started from a filter changed at first. And it may become Setup time x (numbers of changed EQ/Tone/IIR Block+1) in case that directs coefficient setting is used. Moreover, when same data is sent, it is regarded as changed.

(17) Advanced Switch(Other than Fader Volume and Mixing) - Continued

<Time Alignment>

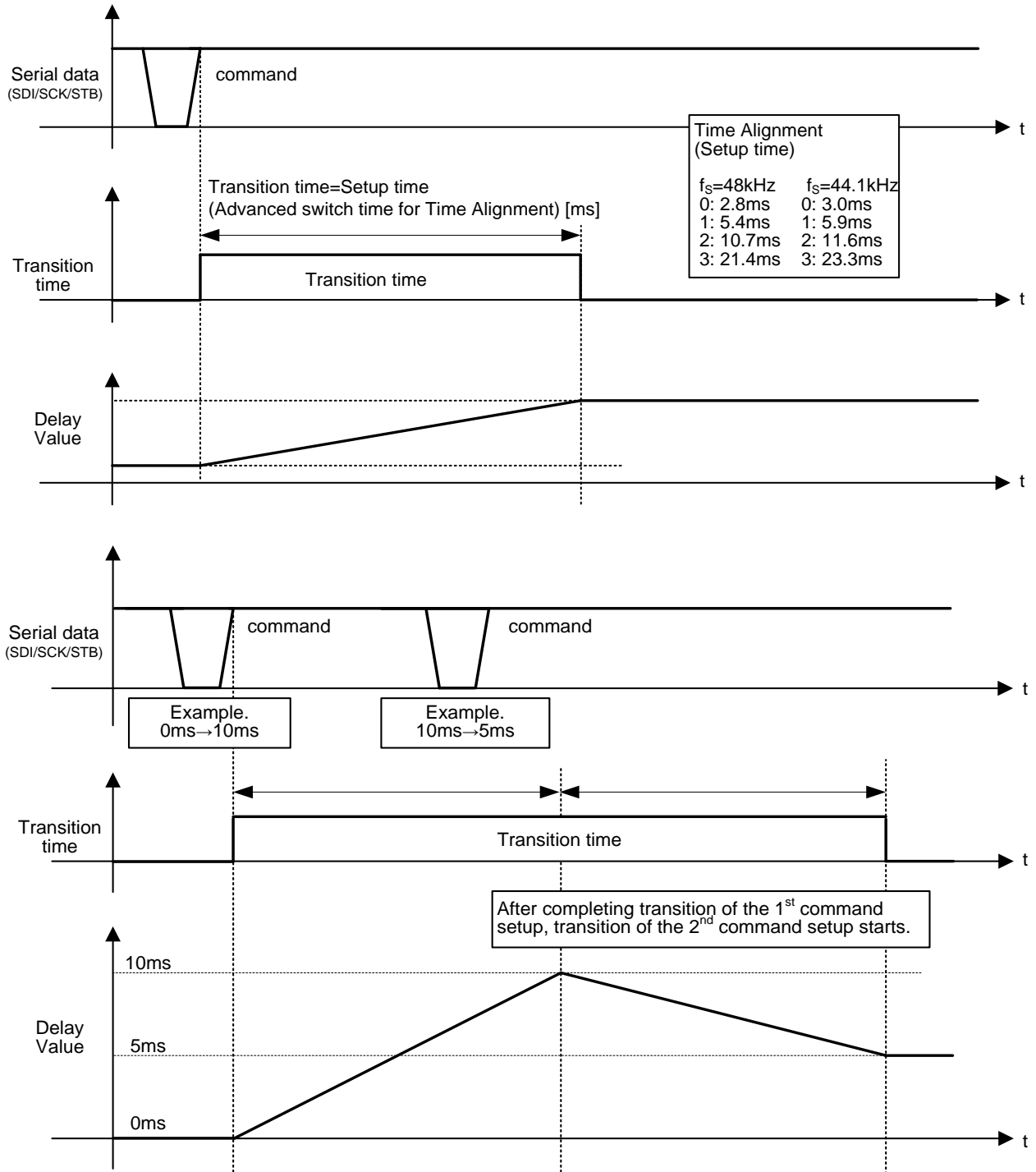

Figure 39. Time Alignment Advanced Switch

(18) Sync Error Detection

[Digital Input1/Input2/Input3]

Outline image of “Sync Error Detection” function for Digital Input1/Input2/Input3 can be seen below.

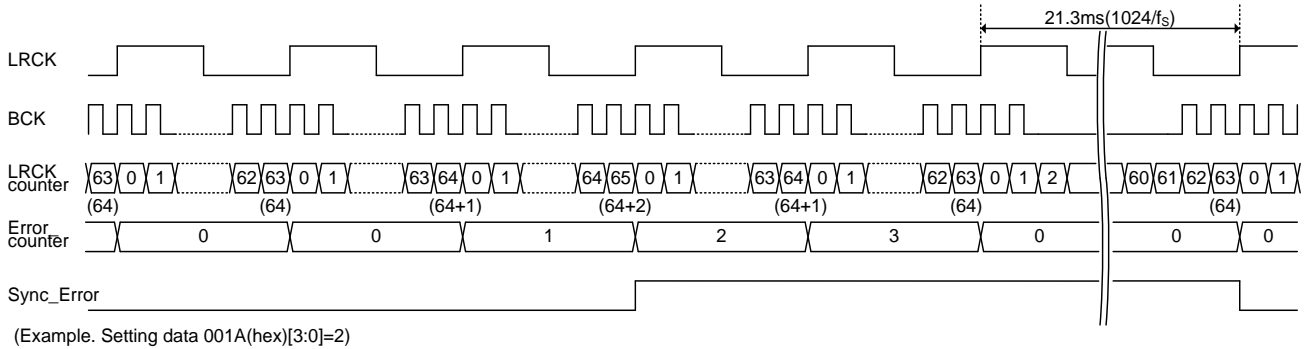

Figure 40. Sync Error detection for Digital Input1/Input2/Input3

The space between each edge of LRCK is counted by BCK(normal=64counts). It is judged as Sync Error Detection when abnormal frame continues for a time equal to or more than the value set in 001A(hex)[3:0] “001B(hex)[3:0], 001C(hex)[3:0]”. The output is then muted. MUTE state is automatically cleared if normal frame is continued for at least 21.3ms(1024/fs).

Status of Sync Error can be read back. (Select Address(A051(hex)), Sync Status)
 0: Normal operation, 1: Sync Error is detected.

And the error detection is not available when Digital IO Format=S/PDIF because of no BCK and LRCK. Set MUTE during Sync Error=Disable. The setting conditions are shown below.

Digital IO Format	Setting		Sync Error detection
	Mute during Sync Error		
I ² S/Left-Justified/Right-Justified	Disable		Not Detectable
	Enable		Detectable
S/PDIF	Disable		Not Detectable
	Enable is Prohibited		

Absolute Maximum Ratings(Ta=25°C)

Item	Symbol	Rating	Unit
Supply Voltage ^(Note 1)	AVDD/DVDD	+7.0	V
Input Voltage	V _{IN}	GND-0.3 to VDD+0.3 (REG: GND-0.3 to +2.1)	V
Operating Temperature ^(Note 2)	Topr	-40 to +85	°C
Storage Temperature	Tstg	-55 to +125	°C
Maximum Junction Temperature	Tjmax	+125	°C

(Note 1) Prevent exceeding the maximum junction temperature rating. AVDD voltage is applied to AVDDL1, AVDDL2, AVDDR1, AVDDR2.

DVDD voltage is applied to DVDD1, DVDD2. DVDD is equal to supply voltage of the microcontroller.

(Note 2) If it is within operating voltage range, function operation is guaranteed within operating temperature. The conditions of the allowable dissipation also have an effect on the temperature so caution is necessary. Conditions where electrical characteristics are not within range must be also avoided. It cannot guarantee standard value of electrical characteristics but it retains its original function.

Caution: Operating the IC over the absolute maximum ratings may damage the IC. The damage can either be a short circuit between pins or an open circuit between pins and the internal circuitry. Therefore, it is important to consider circuit protection measures, such as adding a fuse, in case the IC is operated over the absolute maximum ratings.

Thermal Resistance

Parameter	Symbol	Thermal Resistance ^(Note 3) (Typ)		Unit
		1s ^(Note 5)	2s2p ^(Note 6)	
HTSSOP-B54				
Junction to Ambient	θ _{JA}	66.8	20.1	°C/W
Junction to Top Characterization Parameter ^(Note 4)	Ψ _{JT}	2	2	°C/W

(Note 3) Based on JESD51-2A(Still-Air)

(Note 4) The thermal characterization parameter to report the difference between junction temperature and the temperature at the top center of the outside surface of the component package.

(Note 5) Using a PCB board based on JESD51-3.

(Note 6) Using a PCB board based on JESD51-5, 7.

Layer Number of Measurement Board	Material	Board Size
Single	FR-4	114.3mm x 76.2mm x 1.57mmt

Top	
Copper Pattern	Thickness
Footprints and Traces	70µm

Layer Number of Measurement Board	Material	Board Size	Thermal Via ^(Note 7)	
			Pitch	Diameter
4 Layers	FR-4	114.3mm x 76.2mm x 1.6mmt	1.20mm	Φ0.30mm

Top		2 Internal Layers		Bottom	
Copper Pattern	Thickness	Copper Pattern	Thickness	Copper Pattern	Thickness
Footprints and Traces	70µm	74.2mm x 74.2mm	35µm	74.2mm x 74.2mm	70µm

(Note 7) This thermal via connects with the copper pattern of all layers.

Recommended Operating Condition

(Ta=-40°C to +85°C)

Item	Symbol	Ratings	Unit
Analog Power Supply Voltage	AVDD	4.75 to 6.00	V
Digital Power Supply Voltage	DVDD	3.0 to 3.6	V

*AVDD voltage is applied to AVDDL1, AVDDL2, AVDDR1, AVDDR2.

*DVDD voltage is applied to DVDD1, DVDD2. DVDD is equal to supply voltage of the microcontroller.

Electrical Characteristics: Digital System^(Note 8)

Unless otherwise specified AVDD*^(Note 9)=5.8V, DVDD*^(Note 10)=3.3V, Ta=25°C

Item	Symbol	Limit			Unit	Condition
		Min	Typ	Max		
Input Voltage	High-Level Voltage	V _{IH}	2.4	-	-	V
	Low-Level Voltage	V _{IL}	-	-	0.8	V
Input Current	I _I	-1	-	+1	µA	V _{IN} =0 to 3.3V
Input H Current to Pull-down Resistor	I _{IH}	-	-	100	µA	V _{IN} =1.0V
Output Voltage	High -Level Voltage	V _{OH}	2.75	-	-	V
	Low -Level Voltage	V _{OL}	-	-	0.55	V

(Note 8) Digital System=DI*(DIOA, DIOB, DIOC1, DIOC2, DIOD), BCK*(BCKA, BCKB, BCKC, BCKD),

LRCK*(LRCKA, LRCKB, LRCKC, LRCKD), MCKI, MCKOB, BEEP, STB, SCK, SDI, SDO

(Note 9) AVDD*=AVDDL1, AVDDL2, AVDDR1, AVDDR2

(Note 10) DVDD*=DVDD1, DVDD2

Electrical Characteristics: Analog System

Unless otherwise specified

AVDD*(Note 7)=5.8V, DVDD*(Note 8)=3.3V, Ta=25°C, Vi=1Vrms, Vi_f=1kHz, fs=48kHz, Input Point=Single1

Setting: Send data after System Reset command.

Analog Input Selector=Single1, Analog Mixing Selector=SingleM1, Digital Output1 Selector=C-1, Digital Input1 Selector=B-1, Digital Input3 Selector=B-1, Advanced Switch for P²Bass Gain(Front/Rear)=OFF, DVol(Output2)=0dB, DVol(Att/Boost)(FL/FR/RL/RR/SL/SR)=0dB, Fader Volume(FL/FR/RL/RR/SL/SR)=0dB, fs Selector=48kHz

Item	Symbol	Limit			Unit	Condition
		Min	Typ	Max		
General						
☆ Analog Circuit Current	I _{QA}	-	72	95	mA	AVDD*(Note 7) =5.8V
	I _{QAMAX}	-	75	105	mA	AVDD*(Note 7) =6.0V
☆ Digital Circuit Current	I _{QD}	-	53	90	mA	Total current of DVDD*(Note 8), Input=AC short
	I _{QD} MAX3.3V	-	56	95	mA	DVDD*(Note 8) =3.3V
	I _{QD} MAX3.6V	-	60	116	mA	DVDD*(Note 8) =3.6V
Leakage Current	I _{LKD}	-	0	1	mA	Total current of DVDD*(Note 8), DVDD=0V, AVDD=6.0V, Input=AC short
	I _{LKA}	-	0	1	mA	Total current of AVDD*(Note 7), DVDD=3.3V, AVDD=0V, Input=AC short
Input Selector - ADC – DOUT						
Full Scale Input Voltage	V _{IMAD}	1.9	2.0	-	Vrms	DOUT=0dBFS
	V _{IMAD5V}	1.60	1.73	-	Vrms	DOUT=0dBFS, AVDD=5V
Total Harmonic Distortion + Noise	THD+N _{AD}	-	0.004	0.050	%	(Note 1), (Note 5)
Signal-to-Noise Ratio	S/N _{AD}	90	100	-	dB	(Note 1), (Note 6)
Dynamic Range	DR _{AD}	90	100	-	dB	@-60dBFS (Note 1), (Note 6)
Input Impedance	R _I	70	100	130	kΩ	Analog Input
DIN - DAC - Fader Volume OUT (DSP Input Selector=DC Cut HPF)						
Total Harmonic Distortion + Noise	THD+N _{DA}	-	0.007	0.050	%	DIN=-6dBFS (Note 2), (Note 5)
Signal-to-Noise Ratio	S/N _{DA}	90	99	-	dB	(Note 6)
Dynamic Range	DR _{DA}	90	99	-	dB	@-60dBFS (Note 6)
Full Scale Output Voltage	V _{OMDA}	1.9	2.0	-	Vrms	DIN=0dBFS
	V _{OMDA5V}	1.60	1.73	-	Vrms	DIN=0dBFS, AVDD=5V
Input Selector - ADC - DAC - Fader Volume OUT(DSP Input Selector=ADC)						
Maximum Input Voltage	V _{IM}	1.9	2.0	-	Vrms	THD+N=1% (Note 2), (Note 5)
	V _{IM5V}	1.60	1.73	-	Vrms	THD+N=1% (Note 2), (Note 5), AVDD=5V
Maximum Output Voltage	V _{OM}	1.9	2.0	-	Vrms	THD+N=1% (Note 2), (Note 5)
	V _{OM5V}	1.60	1.73	-	Vrms	THD+N=1% (Note 2), (Note 5), AVDD=5V
Through Gain	G _{V1}	-1	0	+1	dB	Vi_f=1kHz, 20*log(Vo/Vi)
	G _{V2}	-1.0	-0.2	+1.0	dB	Vi_f=20kHz, 20*log(Vo/Vi)
Frequency Gain Balance	BBG	-0.7	-0.2	+0.3	dB	G _{V2} - G _{V1}
Output Noise Voltage	V _{N_R}	-	2	8	μVrms	Input=AC Short, Fader Volume=-∞dB (Note 6)

About measurement Filter

(Note 1) 20kHz LPF

(Note 2) 30kHz LPF

(Note 3) 80kHz LPF

(Note 4) f_s/2 LPF

(Note 5) 400Hz HPF

(Note 6) A-weighted

(Note 7) AVDD*=AVDDL1, AVDDL2, AVDDR1, AVDDR2

(Note 8) DVDD*=DVDD1, DVDD2

Electrical Characteristics: Analog System - Continued

Item	Symbol	Limit			Unit	Condition	
		Min	Typ	Max			
Input Selector - ADC - DAC - Fader Volume OUT(DSP Input Selector=ADC)							
Total Harmonic Distortion + Noise	THD+N	-	0.007	0.050	%	(Note 2), (Note 5)	
Signal-to-Noise Ratio	S/N	90	97	-	dB	S=V _{OM} (Note 6)	
Dynamic Range	DR	90	97	-	dB	@ -60dBFS (Note 6)	
Total Input-Output Characteristics							
Input Pin Voltage	V _{DBI}	2.6	2.9	3.2	V	Analog Input	
Output Impedance	R _O	-	0.6	50.0	Ω	Analog Output	
Output Pin Voltage	V _{DBO}	2.6	2.9	3.2	V	Analog Output	
Crosstalk between Channels(Lch/Rch)	C _{CH}	-	-96	-80	dB	L(R)ch Analog Input→R(L)ch monitor (opposite ch's input=AC short), Monitor=Fader Volume Front/Rear, Digital Selector=ADC, Vi=1.9Vrms (Note 7)	
Ripple Rejection	PRR	-	-55	-40	dB	AIN=AC short, Ripple=0.1Vrms (Note 7), Input=AVDD (Note 8) / AVDD (Note 8) & DVDD (Note 9)	
Fader Volume Circuit Characteristics							
Maximum Volume Attenuation	GAT _{Fmt}	-81.5	-79.0	-76.5	dB	Fader Volume=-79dB - 0dB, Vi=1.9Vrms (Note 6)	
	GAT _{Fmx}	-	-105	-95	dB	Fader Volume=-∞dB - 0dB, Vi=1.9Vrms (Note 6)	
Gain Balance between Channels	B _{V1}	-0.5	0	+0.5	dB	Fader Volume(0dB to -20dB) (Note 6), Vi=1.9Vrms	
	B _{V2}	-0.9	0	+0.9	dB	Fader Volume(-20dB to -79dB) (Note 6), Vi=1.9Vrms	
Isolator Circuit Characteristics							
Common Mode Rejection Ratio	CMRR	-	-65	-50	dB	Input Selector=Diff A/Diff M1	
Input Gain Circuit Characteristics							
Input Gain Setting Value	G _{I24}	23	24	25	dB	Gain=24dB - 0dB, Vi=0.1Vrms	
Gain Balance between Channels	B _I	-0.5	0	+0.5	dB	Gain(24dB to 0dB), Vi=0.1Vrms	
Mixing Volume Circuit Characteristics							
Maximum Volume Attenuation	GAT _{AM1}	-65.5	-63.0	-60.5	dB	AVol(AMix)=-63dB - 0dB	Analog Mixing=ON, Fader Volume =-∞dB (Note 6), Vi=1.9Vrms
	GAT _{AMX}	-	-98	-90	dB	AVol(AMix)=-∞dB - 0dB	
	GAT _{DM1}	-71.5	-69.0	-60.5	dB	AVol(DMix)=-69dB - 0dB	Sub Selector=SL/SL, Digital Mixing=ON, Fader Volume =-∞dB (Note 6), DIN=0dBFS
	GAT _{DM2}	-	-98	-90	dB	AVol(DMix)=-∞dB - 0dB	
Gain Balance between Channels	B _{VA1}	-0.5	0	+0.5	dB	AVol(AMix) (+6dB to -20dB), Vi=0.9Vrms	Analog Mixing=ON, Fader Volume =-∞dB (Note 6)
	B _{VA2}	-0.9	0	+0.9	dB	AVol(AMix) (-20dB to -63dB), Vi=1.9Vrms	

About measurement Filter
 (Note 1) 20kHz LPF,
 (Note 2) 30kHz LPF,
 (Note 3) 80kHz LPF,
 (Note 4) f_s/2 LPF,
 (Note 5) 400Hz HPF,
 (Note 6) A-weighted,
 (Note 7) BPF(f_c=Vi_f)
 (Note 8) AVDD*=AVDDL1, AVDDL2, AVDDR1, AVDDR2
 (Note 9) DVDD*=DVDD1, DVDD2

Measurement Circuit

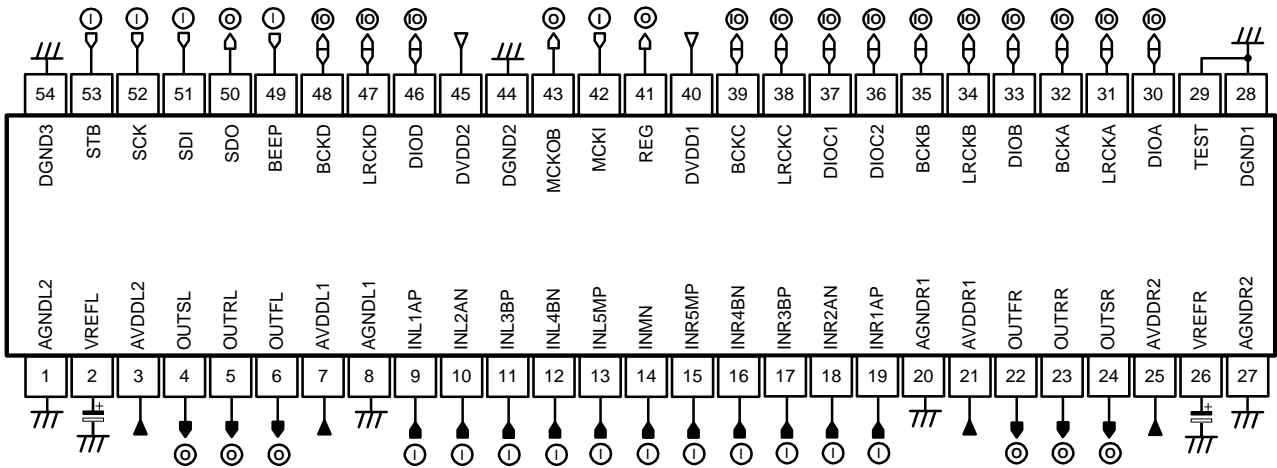

Figure 41. Measurement Circuit Diagram

<p>Measuring Circuit External Parts</p> <ul style="list-style-type: none"> • Resistor: $\pm 1\%$ • Capacitor: $\pm 1\%$
<p>About Digital Power Supply</p> <p>DVDD1/DVDD2 are equal to supply voltage(Recommended operating condition: 3.0V to 3.6V) of the microcontroller.</p>
<p>Notes on wiring</p> <ol style="list-style-type: none"> 1. Decoupling capacitor of a power supply should be connected to VDD and GND in the shortest distance possible. 2. Lines of AGND should be connected to one point only. 3. Digital Wiring Pattern should be far from that of analog unit and see to it that there will be no crosstalk. 4. If possible, serial control lines should not be in parallel. If they are adjacent to each other, the lines have to be shielded. 5. If possible, lines of Analog Input should not be in parallel. If they are adjacent to each other, the lines have to be shielded. 6. Connect the TEST pin to the DGND1 pin.

Pin Measurement Circuit

Item	Test circuit	Condition	Connection Pin	
			Pin No.	Pin Name
Power Supply		$R_g=0\Omega$ $V_{RR}=100mV_{rms}$ $f=1kHz$	3 25 7 21 40 45	AVDDL2 AVDDR2 AVDDL1 AVDDR1 DVDD1 DVDD2
Input		$R=100k\Omega$ $C=10\mu F$ $R_g=600\Omega$	9 19 10 18 11 17 12 16 13 15 14	INL1AP INR1AP INL2AN INR2AN INL3BP INR3BP INL4BN INR4BN INL5MP INR5MP INMN
Output		$R_{o1}=10k\Omega$ $R_{o2}=10k\Omega$ $C=0.47\mu F$	4 24 5 23 6 22	OUTSL OUTSR OUTRL OUTRR OUTFL OUTFR
Serial Control		$V_{IH}=2.4V$ $V_{IL}=0.8V$	49 50 51 52 53	BEEP SDO SDI SCK STB
3-Wire Serial Audio		$V_{IH}=2.4V$ $V_{IL}=0.8V$	30 31 32 33 34 35 36 37 38 39 46 47 48	DIOA LRCKA BCKA DIOB LRCKB BCKB DIOC2 DIOC1 LRCKC BCKC DIOD LRCKD BCKD
Regulator Output		$I_{REG}=95mA$	41	REG

Typical Performance Curves

Unless otherwise specified : AVDD*(Note 1)=5.8V, DVDD*(Note 2)=3.3V, Ta=25°C, fs=48kHz

(Note 1) AVDD*=AVDDL1, AVDDL2, AVDDR1, AVDDR2

(Note 2) DVDD*=DVDD1, DVDD2

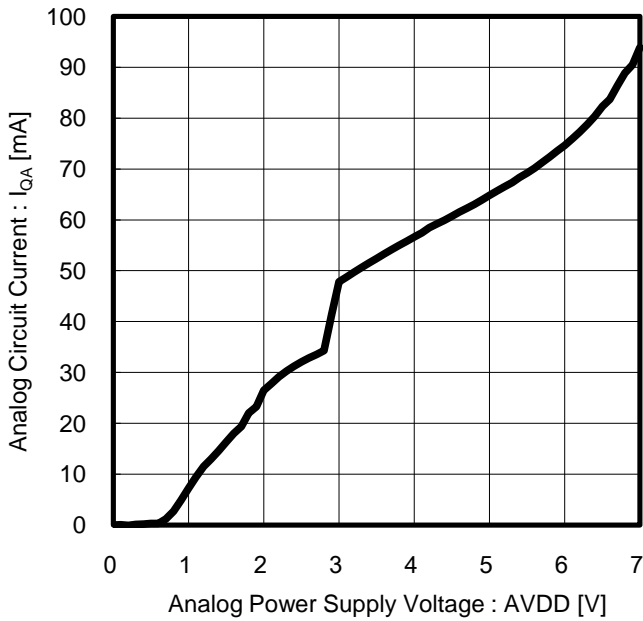

Figure 42. Analog Circuit Current vs Analog Power Supply Voltage

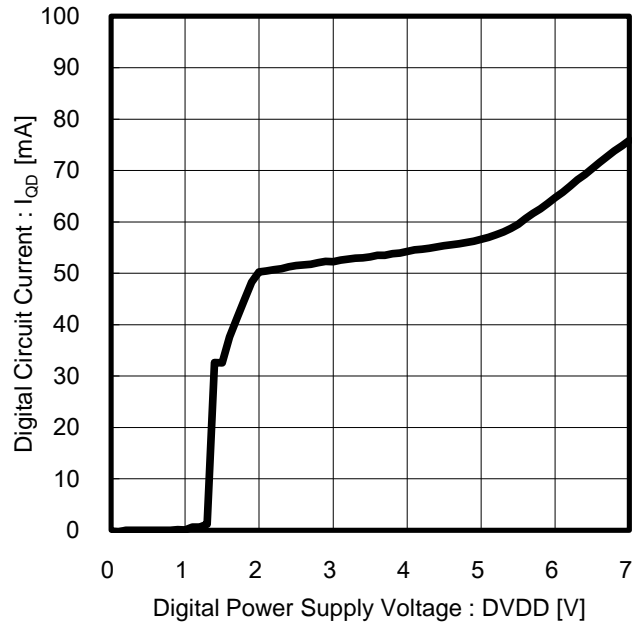

Figure 43. Digital Circuit Current vs Digital Power Supply Voltage

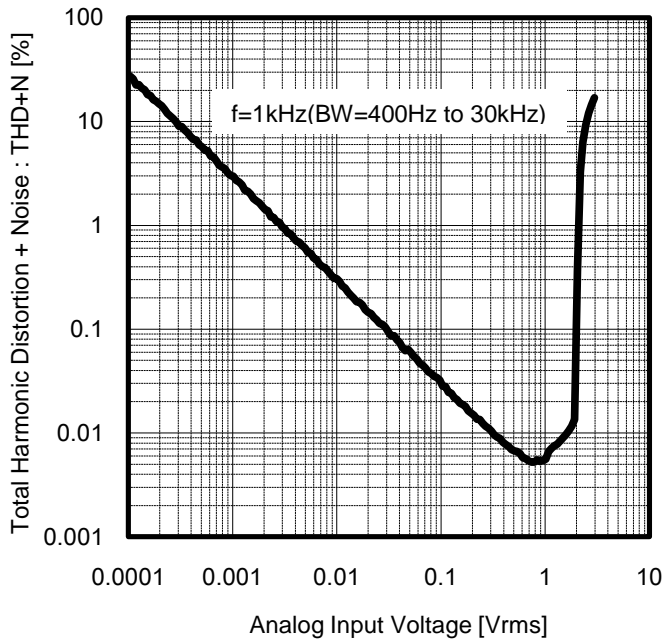

Figure 44. Total Harmonic Distortion + Noise vs Analog Input Voltage
(Analog Input Selector-ADC-DAC-Fader Volume-Analog Output)

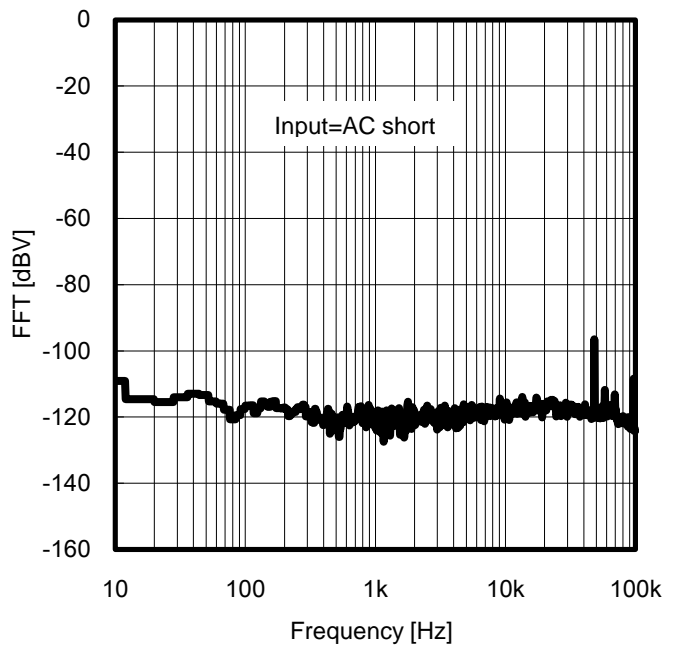

Figure 45. FFT vs Frequency
(Analog Input Selector-ADC-DAC-Fader Volume-Analog Output)

Typical Performance Curves - Continued

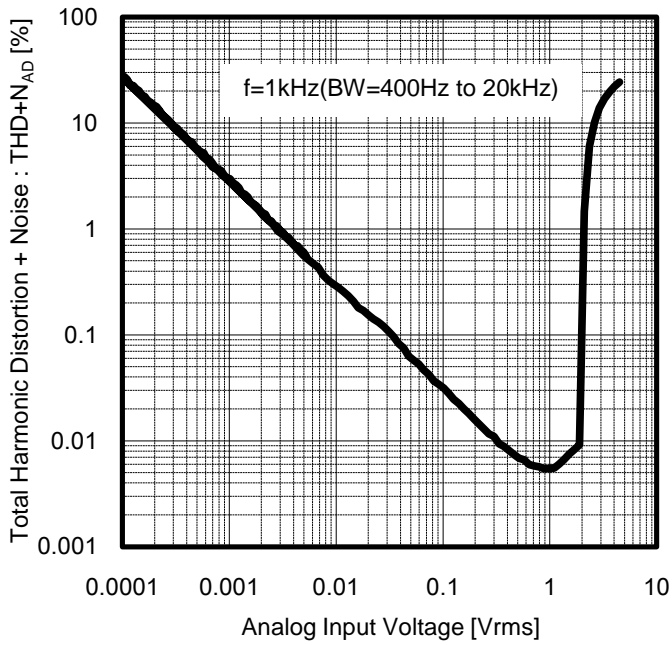

Figure 46. Total Harmonic Distortion + Noise vs Analog Input Voltage (Analog Input Selector-ADC-DOUT)

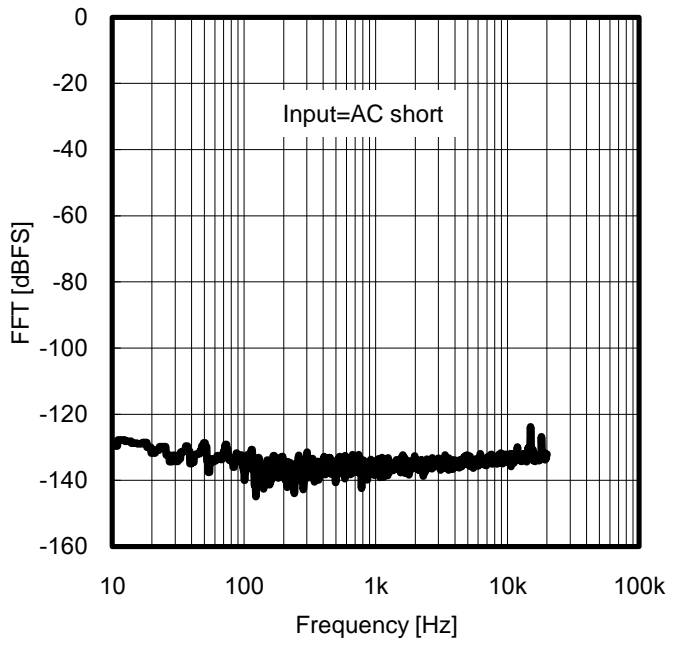

Figure 47. FFT vs Frequency (Analog Input Selector-ADC-DOUT)

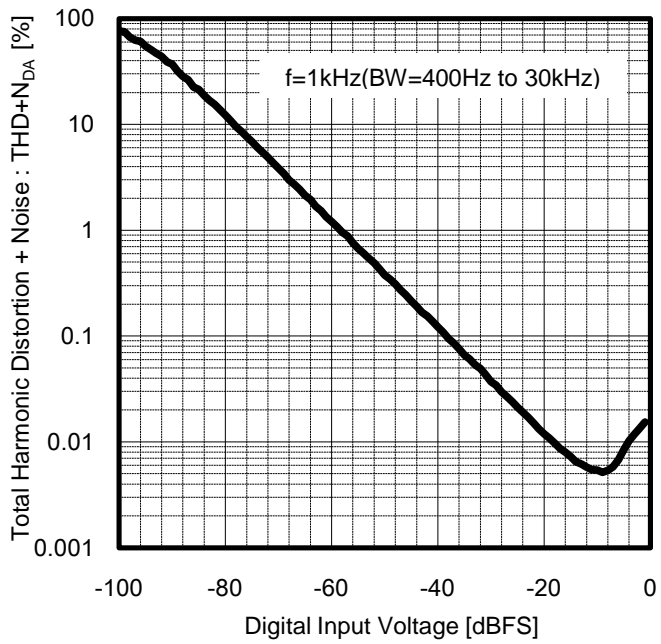

Figure 48. Total Harmonic Distortion + Noise vs Digital Input Voltage (DIN-DAC-Fader Volume-Analog Output)

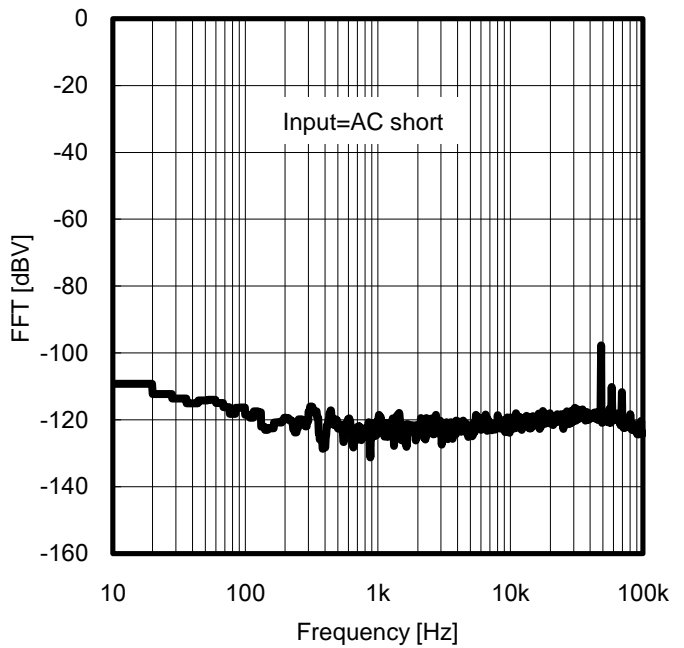

Figure 49. FFT vs Frequency (DIN-DAC-Fader Volume-Analog Output)

Typical Performance Curves - Continued

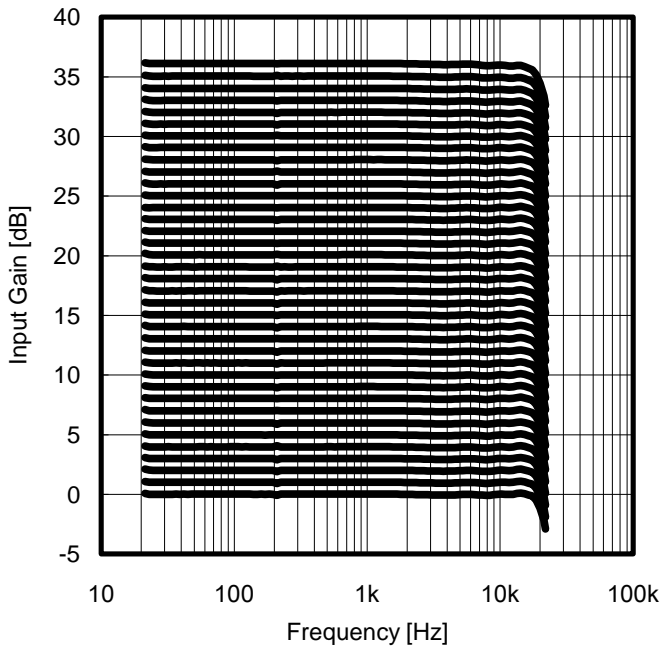

Figure 50. Input Gain vs Frequency
(Gain=36dB to 0dB/1dB step)

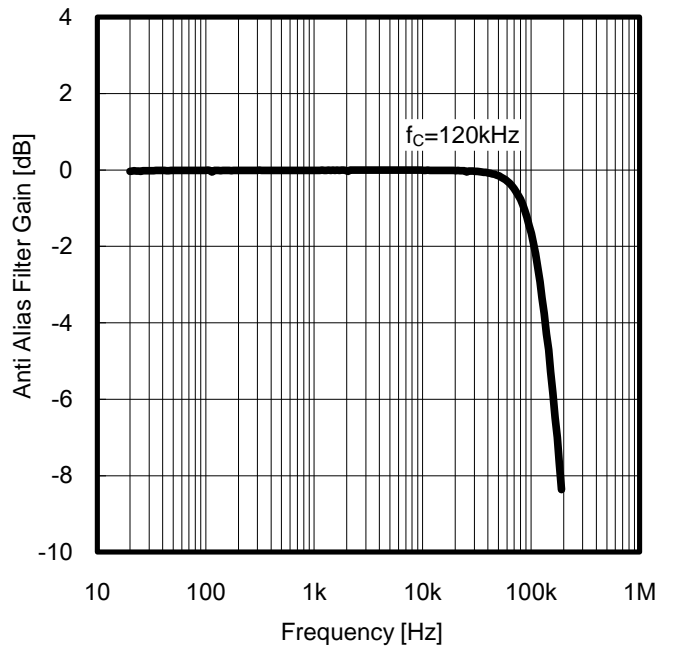

Figure 51. Anti Alias Filter Gain vs Frequency

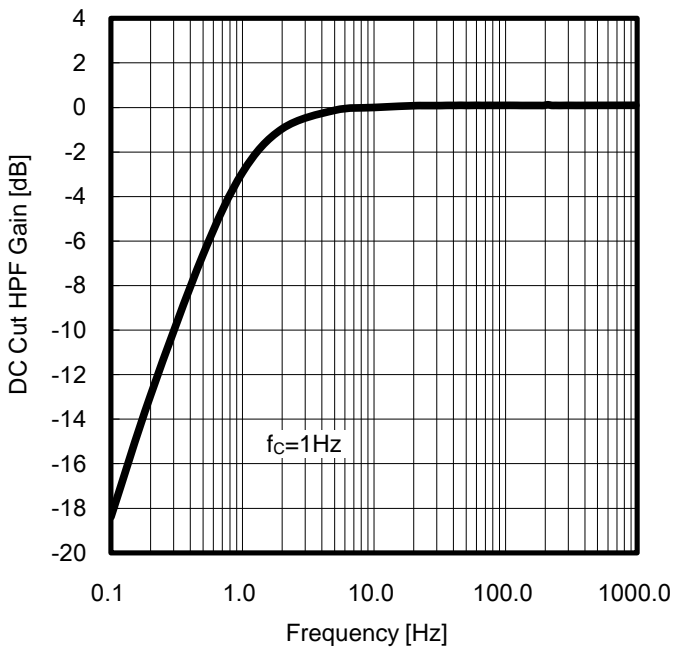

Figure 52. DC Cut HPF Gain vs Frequency

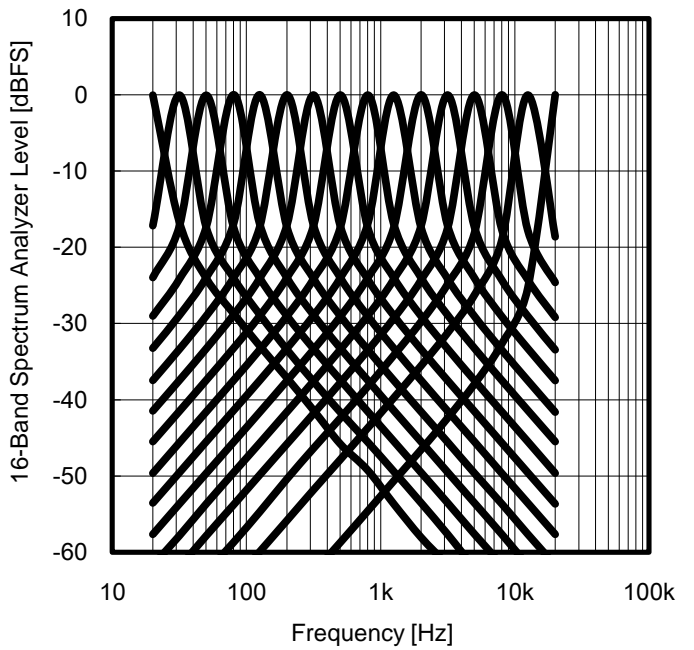

Figure 53. 16-Band Spectrum Analyzer Level vs Frequency
($f_0=20/31.5/50/80/125/200/315/500/800/1.25k/2k/3.15k/5k/8k/12.5k/20kHz$)

Typical Performance Curves - Continued

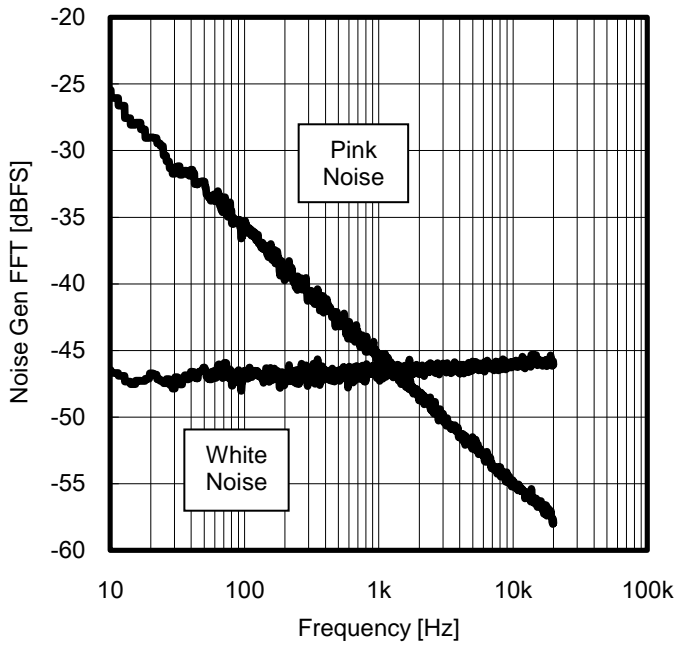

Figure 54. Noise Gen FFT vs Frequency

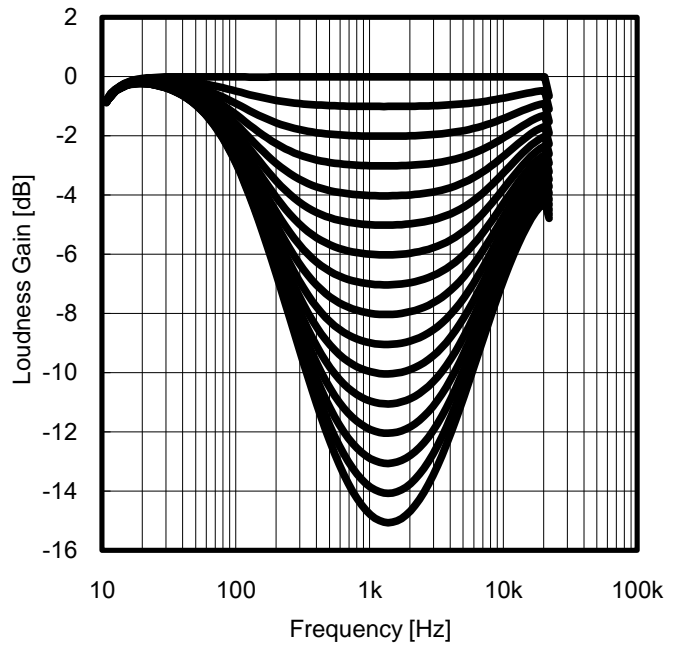

Figure 55. Loudness Gain vs Frequency
(Gain=0dB to -15dB/1dB step, LPF $f_c=100\text{Hz}$,
HPF $f_c=10\text{kHz}$, HiBoost=0.55)

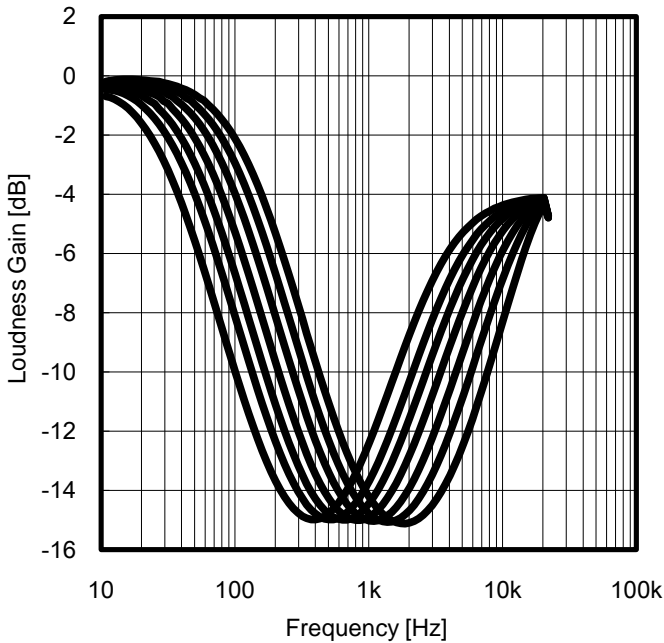

Figure 56. Loudness Gain vs Frequency
(Gain=-15dB, HiBoost=0.55,
LPF $f_c=30\text{Hz}$, HPF $f_c=3\text{kHz}$ /
LPF $f_c=40\text{Hz}$, HPF $f_c=4\text{kHz}$ /
LPF $f_c=50\text{Hz}$, HPF $f_c=5\text{kHz}$ /
LPF $f_c=63\text{Hz}$, HPF $f_c=6.3\text{kHz}$ /
LPF $f_c=80\text{Hz}$, HPF $f_c=8\text{kHz}$ /
LPF $f_c=100\text{Hz}$, HPF $f_c=10\text{kHz}$ /
LPF $f_c=125\text{Hz}$, HPF $f_c=12.5\text{kHz}$)

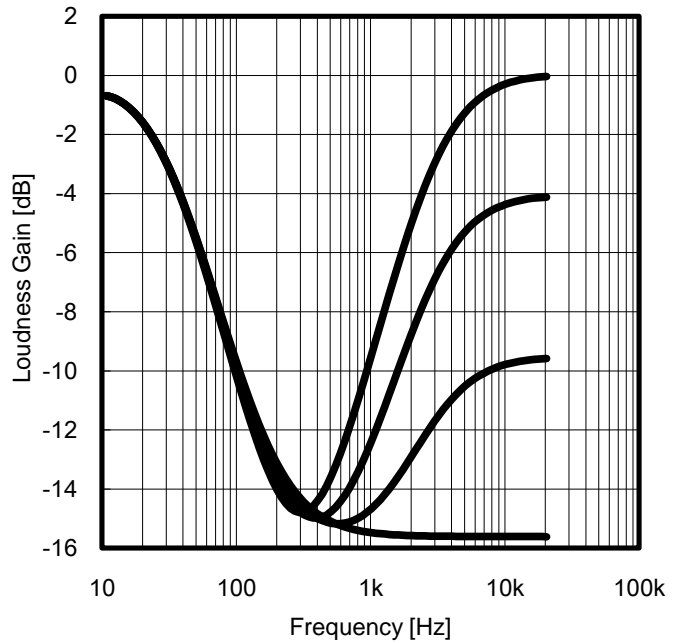

Figure 57. Loudness Gain vs Frequency
(Gain=-15dB, LPF $f_c=100\text{Hz}$,
HPF $f_c=10\text{kHz}$, HiBoost=0/0.2/0.55/1)

Typical Performance Curves - Continued

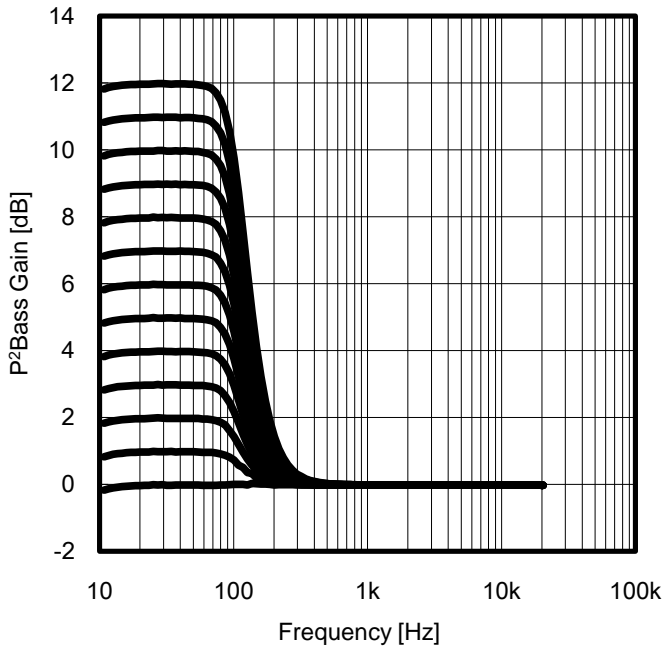

Figure 58. P²Bass Gain vs Frequency
(Gain=12dB to 0dB/1dB step, f_c=108Hz)

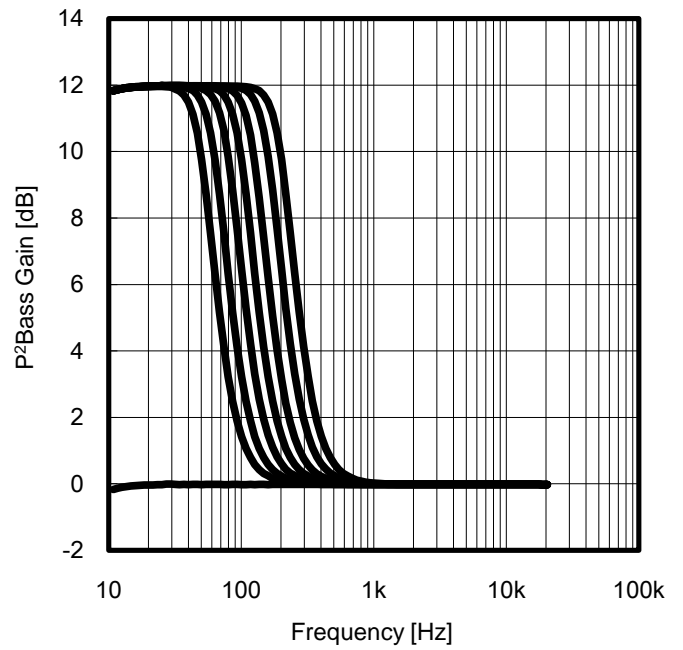

Figure 59. P²Bass Gain vs Frequency
(Gain=12dB, f_c=54/68/86/108/134/172/214Hz)

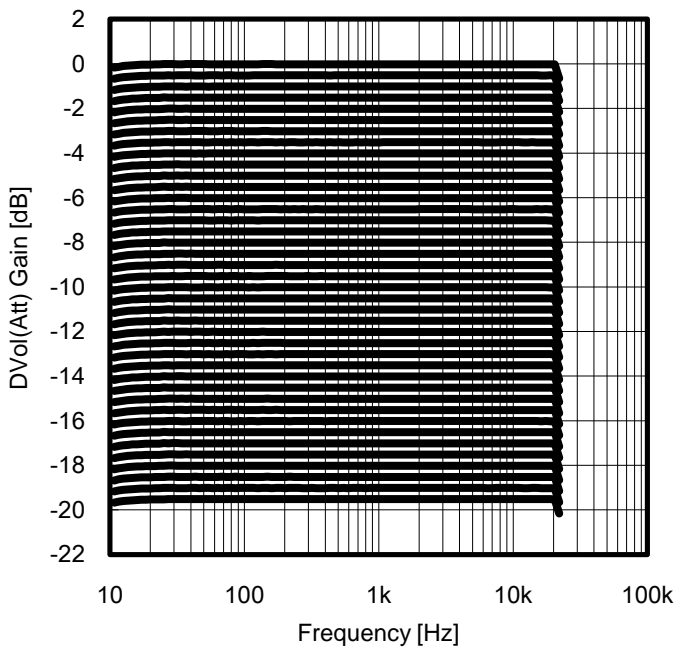

Figure 60. DVol(Att) Gain vs Frequency
(Gain=0dB to -19.5dB/0.5dB step)

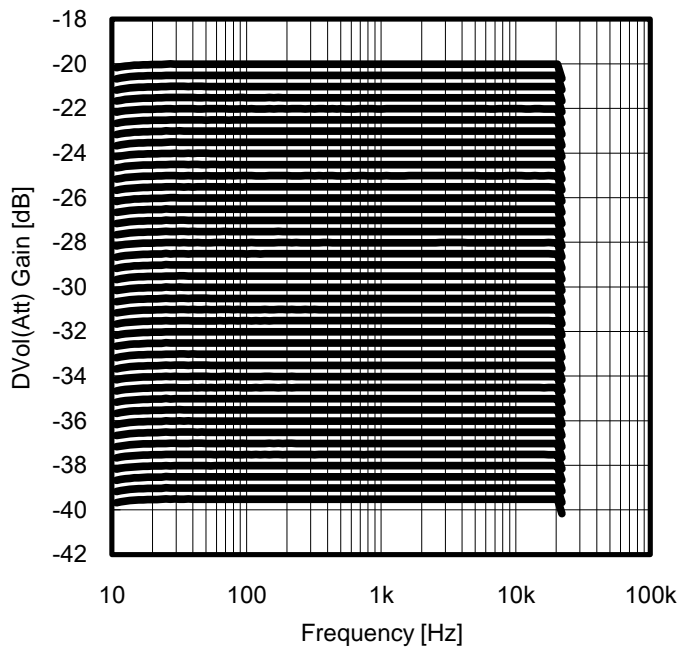

Figure 61. DVol(Att) Gain vs Frequency
(Gain=-20dB to -39.5dB/0.5dB step)

Typical Performance Curves - Continued

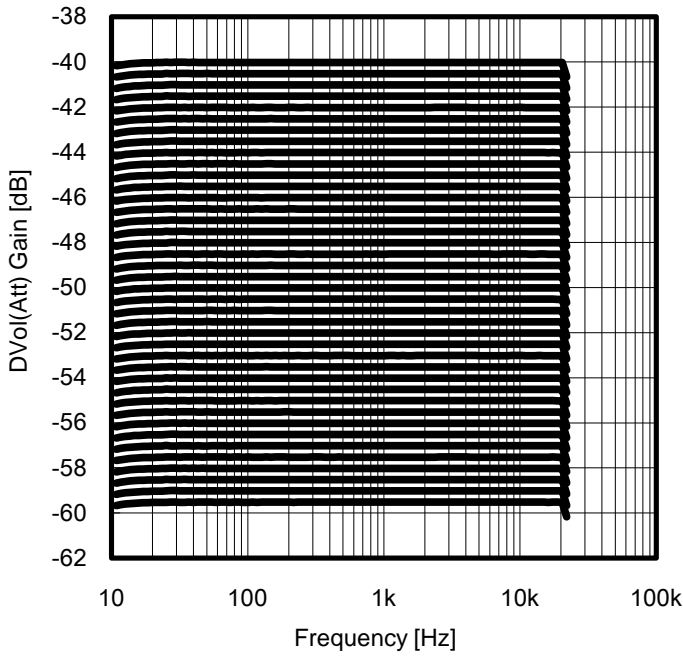

Figure 62. DVol(Att) Gain vs Frequency
(Gain=-40dB to -59.5dB/0.5dB step)

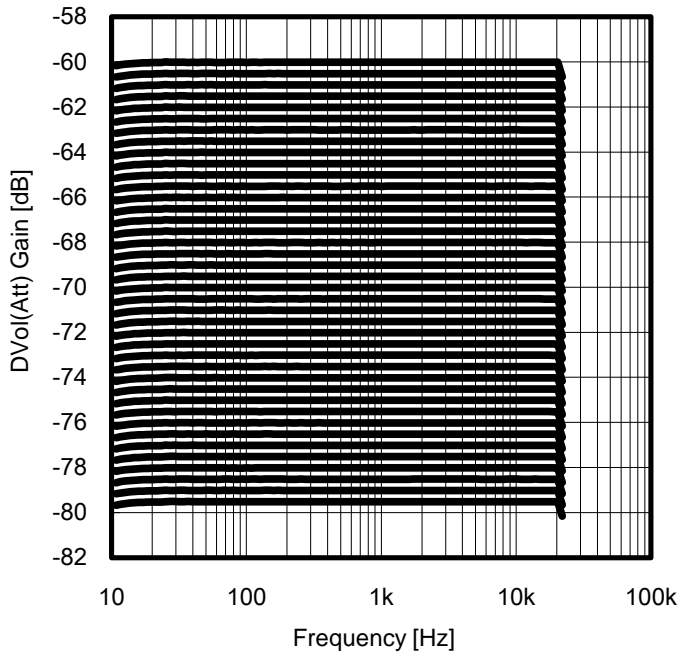

Figure 63. DVol(Att) Gain vs Frequency
(Gain=-60dB to -79.5dB/0.5dB step)

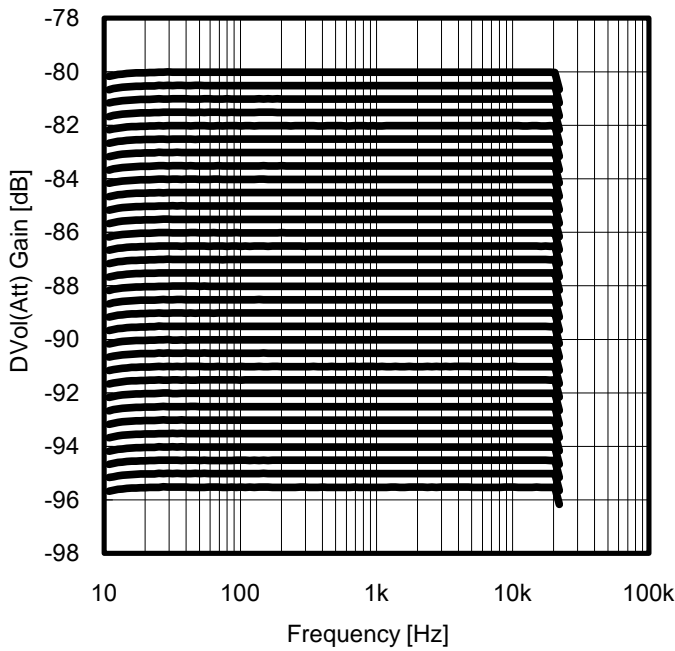

Figure 64. DVol(Att) Gain vs Frequency
(Gain=-80dB to -95.5dB/0.5dB step)

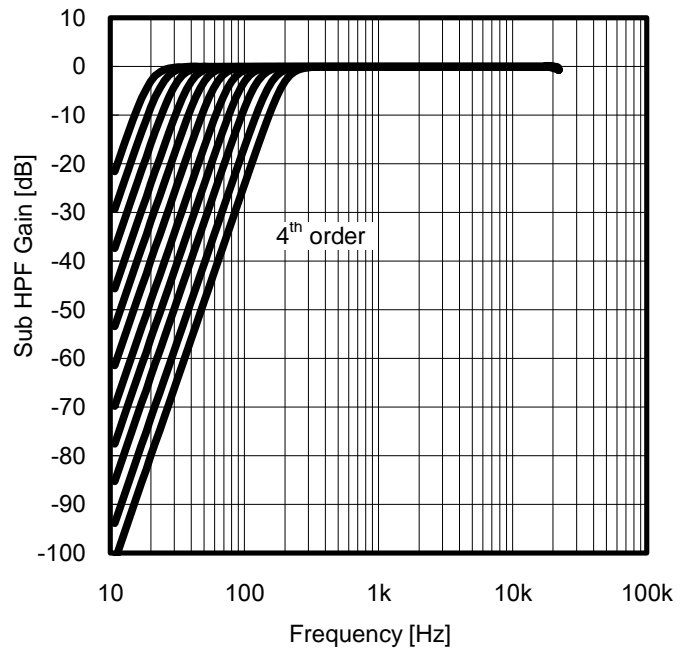

Figure 65. Sub HPF Gain vs Frequency
($f_c=20/25/31.5/40/50/63/80/100/125/160/200\text{Hz}$)

Typical Performance Curves - Continued

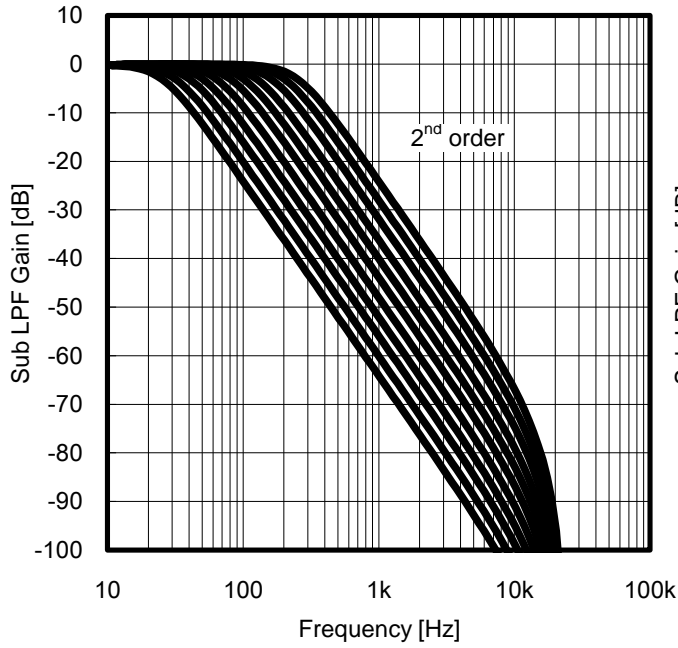

Figure 66. Sub LPF Gain vs Frequency
($f_c=25/31.5/40/50/63/80/100/125/160/200/250\text{Hz}$)

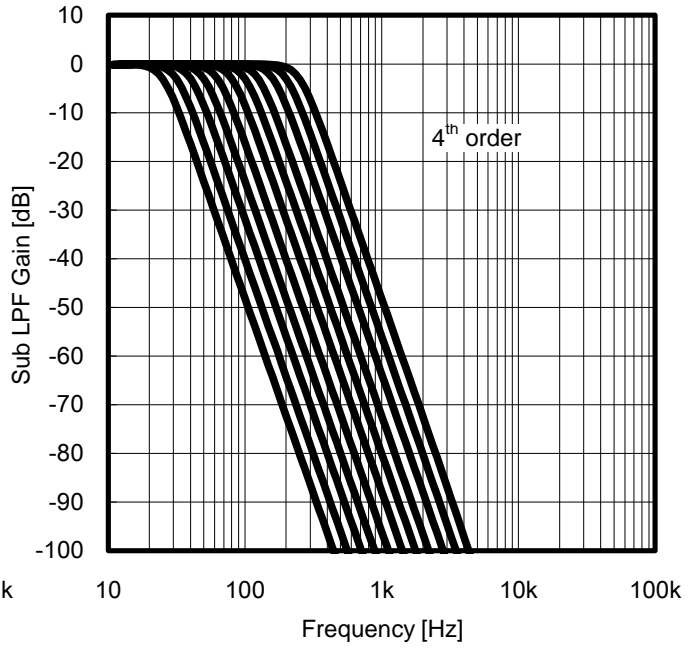

Figure 67. Sub LPF Gain vs Frequency
($f_c=25/31.5/40/50/63/80/100/125/160/200/250\text{Hz}$)

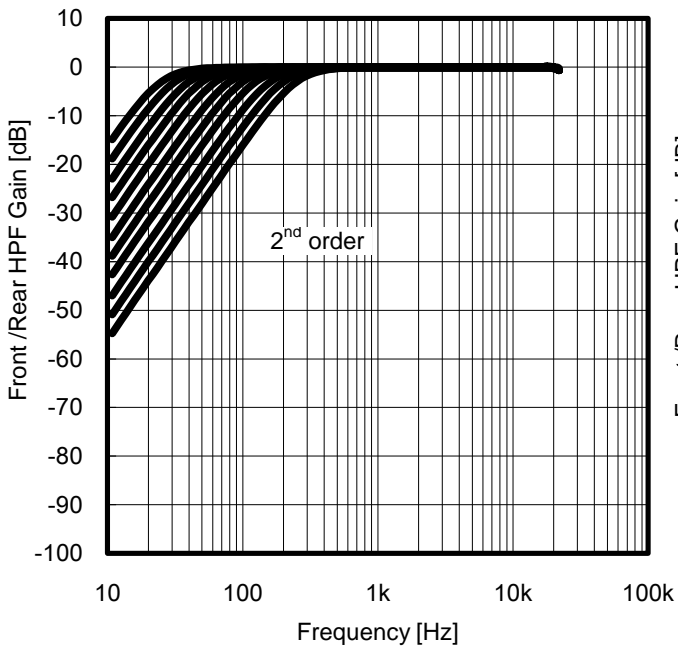

Figure 68. Front/Rear HPF Gain vs Frequency
($f_c=25/31.5/40/50/63/80/100/125/160/200/250\text{Hz}$)

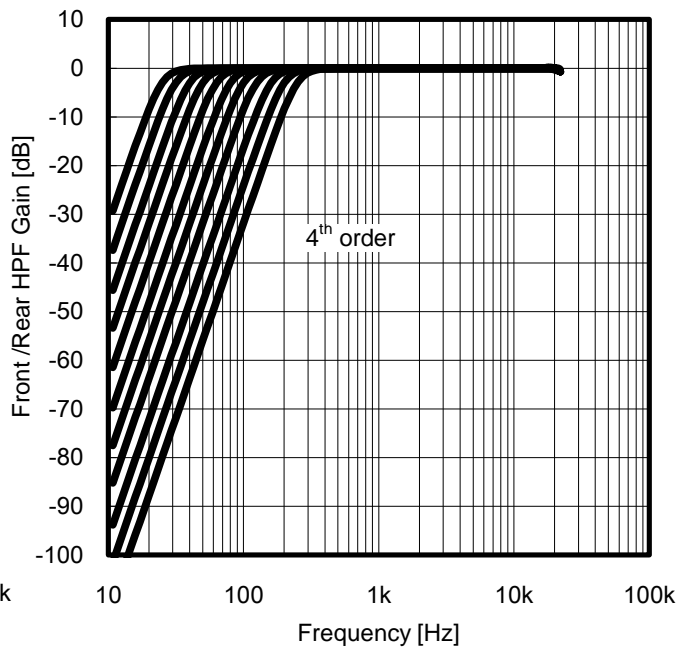

Figure 69. Front/Rear HPF Gain vs Frequency
($f_c=25/31.5/40/50/63/80/100/125/160/200/250\text{Hz}$)

Typical Performance Curves - Continued

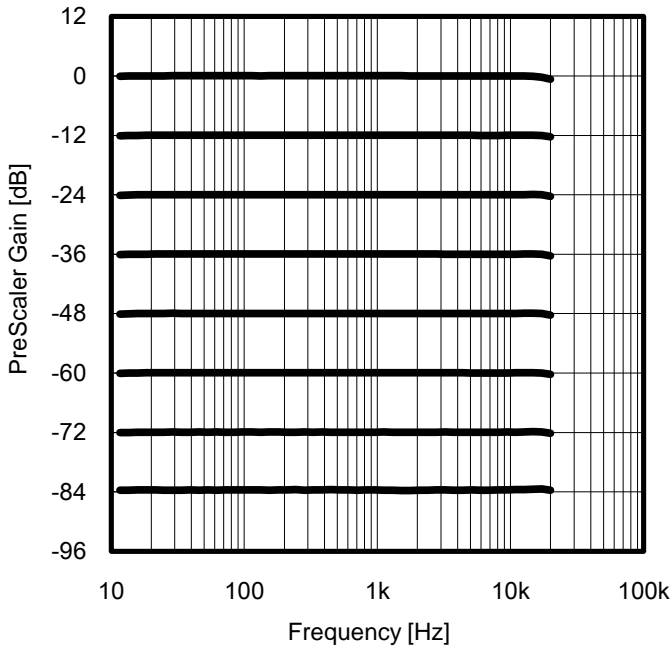

Figure 70. PreScaler Gain vs Frequency
(Gain=0dB to -84dB/12dB step)

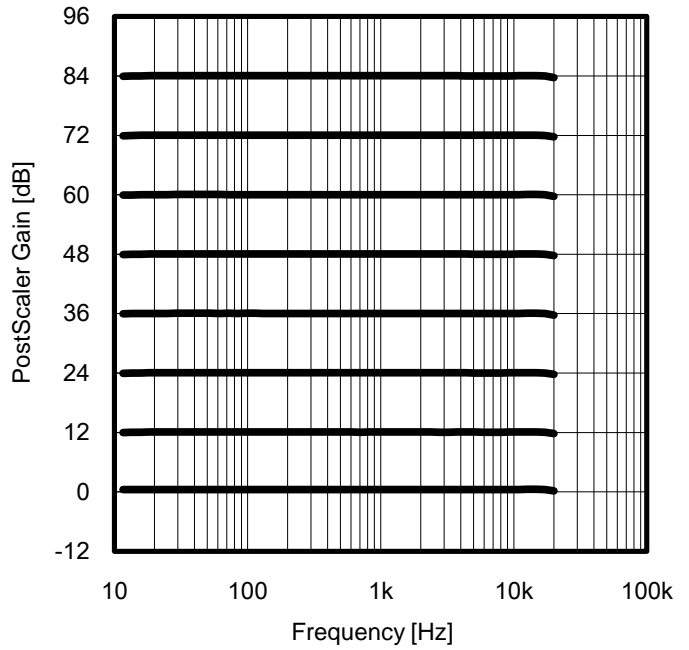

Figure 71. PostScaler Gain vs Frequency
(Gain=84dB to 0dB/12dB step)

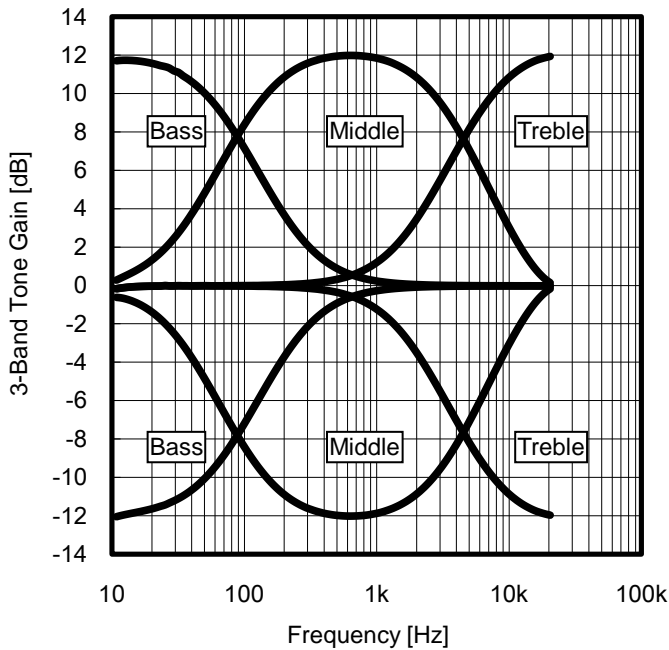

Figure 72. 3-Band Tone Gain vs Frequency
(Gain=+12dB/-12dB, Bass $f_c=63\text{Hz}$, Middle $f_0=630\text{Hz}$, Treble $f_c=6.3\text{kHz}$)

Typical Performance Curves - Continued

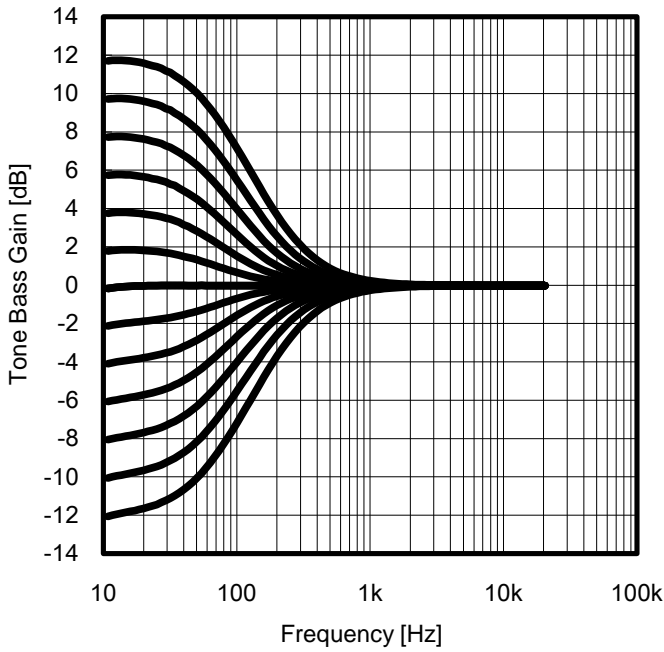

Figure 73. Tone Bass Gain vs Frequency
(Gain=+12dB to -12dB/2dB step, $f_c=63\text{Hz}$)

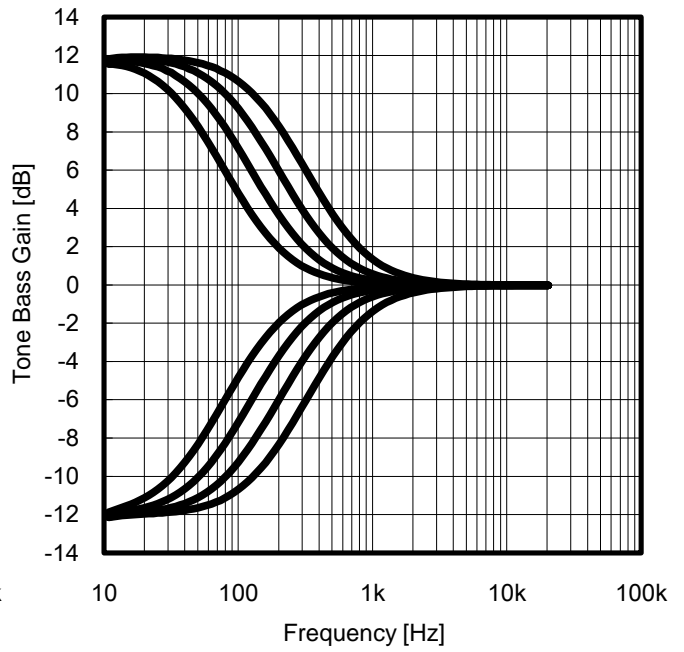

Figure 74. Tone Bass Gain vs Frequency
(Gain=+12dB/-12dB, $f_c=40/63/100/160\text{Hz}$)

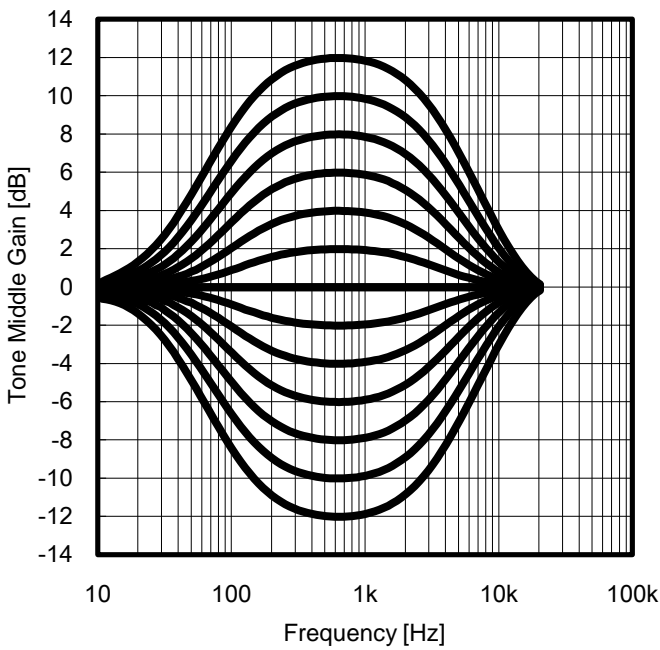

Figure 75. Tone Middle Gain vs Frequency
(Gain=+12dB to -12dB/2dB step, $f_0=630\text{Hz}$)

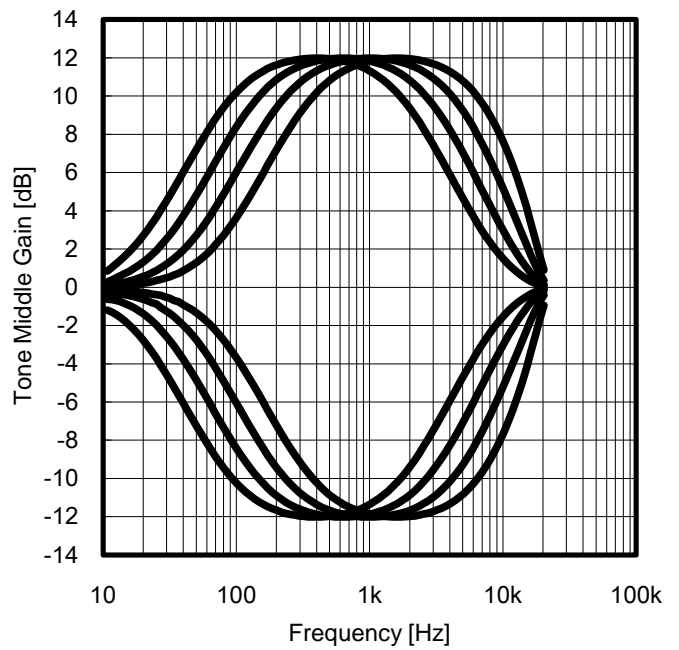

Figure 76. Tone Middle Gain vs Frequency
(Gain=+12dB/-12dB, $f_0=400/630/1\text{k}/1.6\text{kHz}$)

Typical Performance Curves - Continued

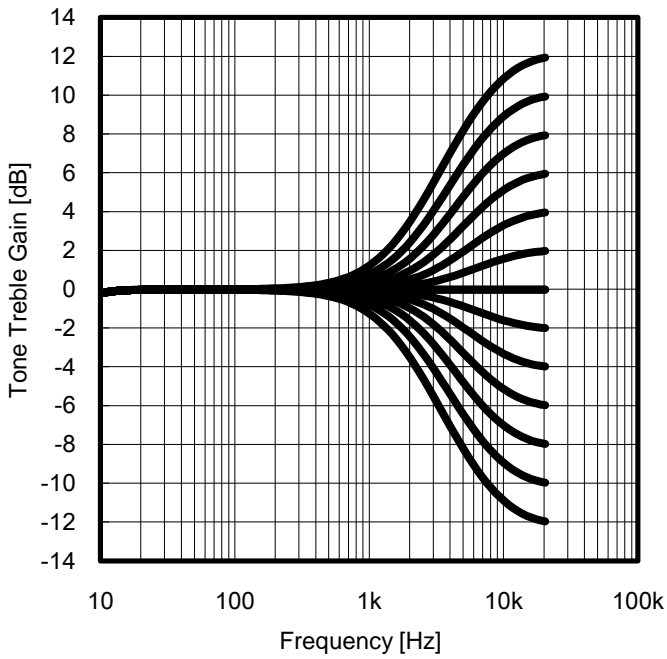

Figure 77. Tone Treble Gain vs Frequency (Gain=+12dB to -12dB/2dB step, $f_c=6.3\text{kHz}$)

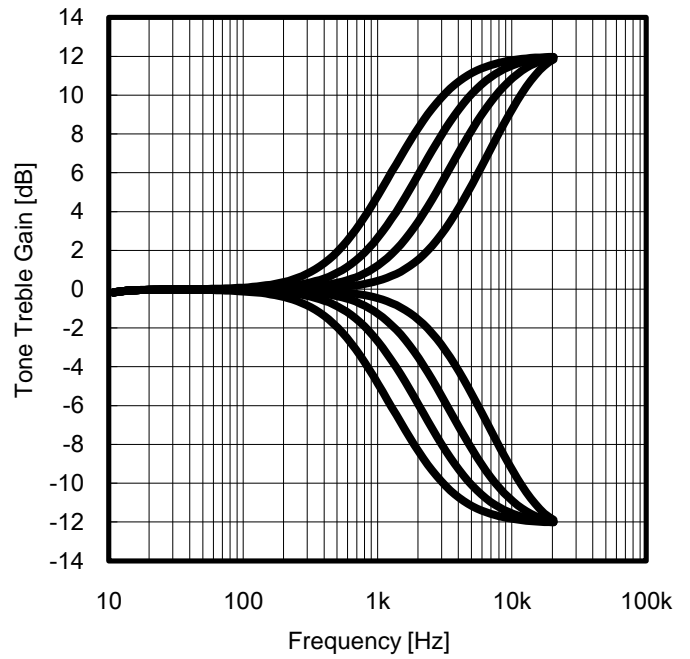

Figure 78. Tone Treble Gain vs Frequency (Gain=+12dB/-12dB, $f_c=2.5\text{k}/4\text{k}/6.3\text{k}/10\text{kHz}$)

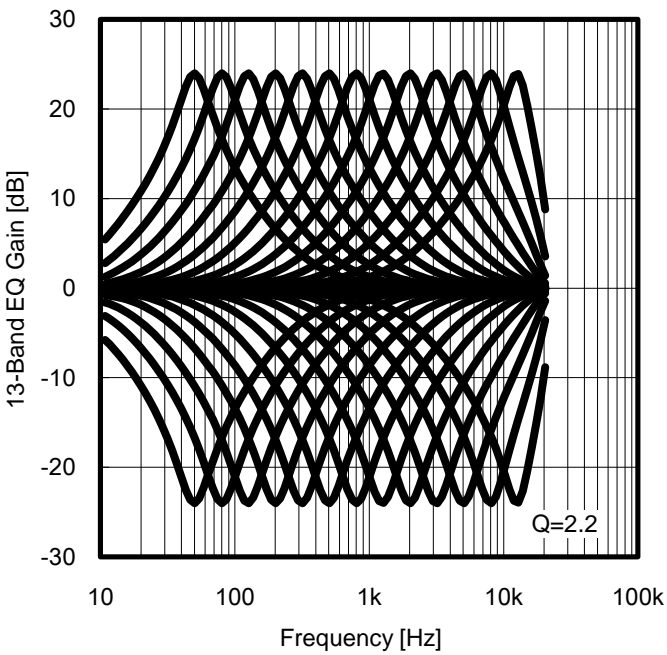

Figure 79. 13-Band EQ Gain vs Frequency (Gain=+24dB/-24dB, $f_0=50/80/125/200/315/500/800/1.25\text{k}/2\text{k}/3.15\text{k}/5\text{k}/8\text{k}/12.5\text{kHz}$)

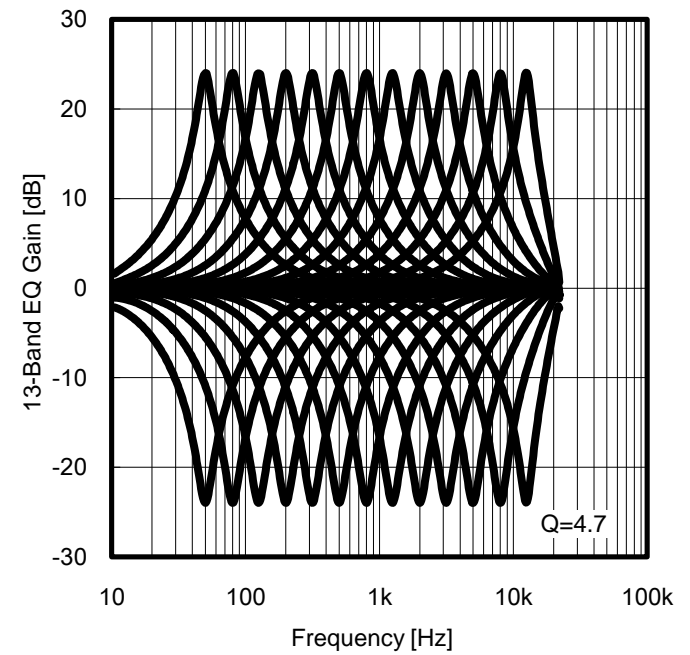

Figure 80. 13-Band EQ Gain vs Frequency (Gain=+24dB/-24dB, $f_0=50/80/125/200/315/500/800/1.25\text{k}/2\text{k}/3.15\text{k}/5\text{k}/8\text{k}/12.5\text{kHz}$)

Typical Performance Curves - Continued

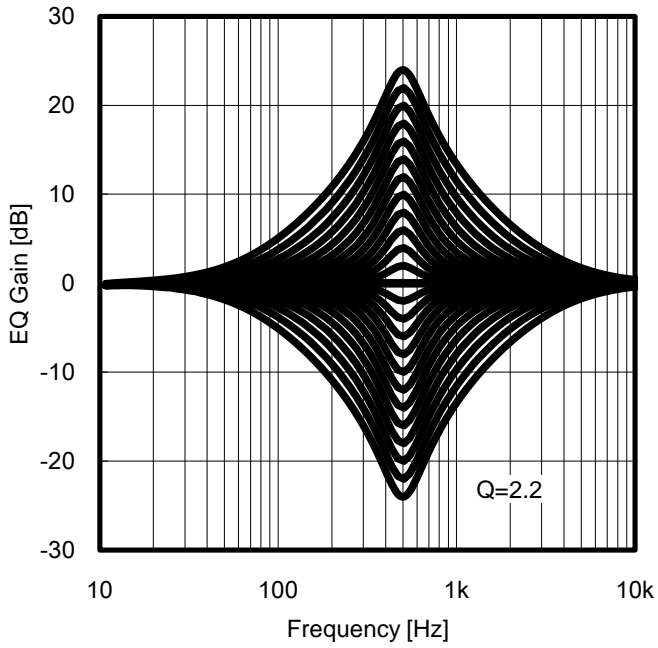

Figure 81. EQ Gain vs Frequency
(EQ6, Gain=+24dB to -24dB/2dB step, $f_0=500\text{Hz}$)

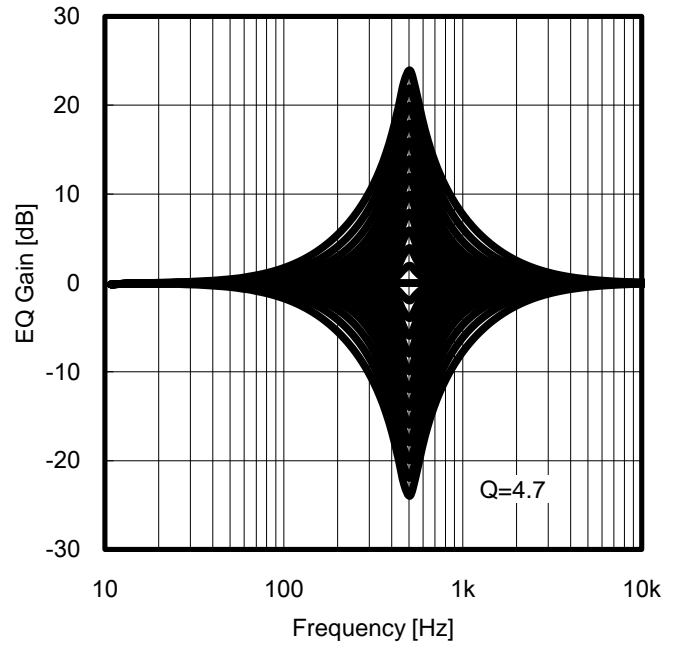

Figure 82. EQ Gain vs Frequency
(EQ6, Gain=+24dB to -24dB/2dB step, $f_0=500\text{Hz}$)

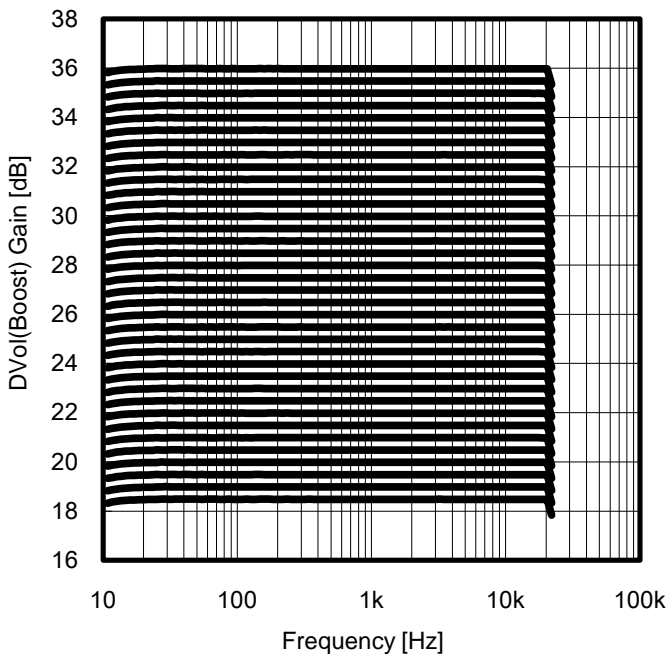

Figure 83. DVol(Boost) Gain vs Frequency
(Gain=36dB to 18.5dB/0.5dB step)

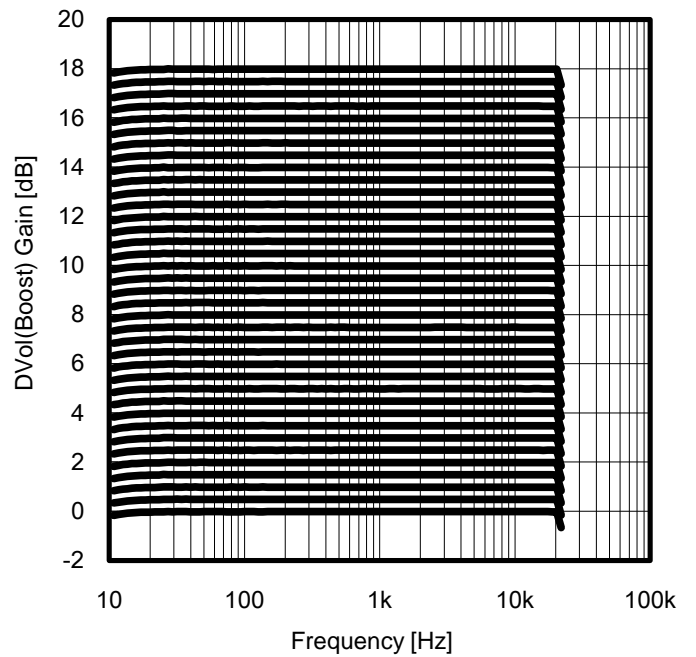

Figure 84. DVol(Boost) Gain vs Frequency
(Gain=18dB to 0dB/0.5dB step)

Typical Performance Curves - Continued

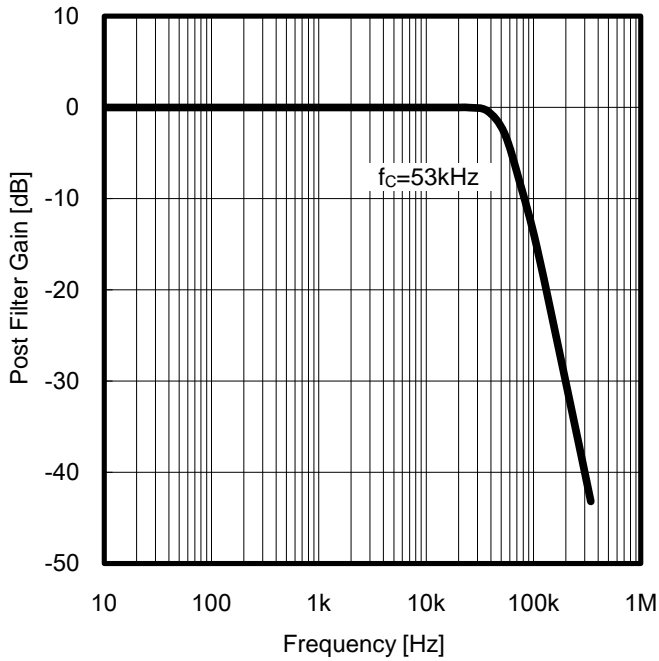

Figure 85. Post Filter Gain vs Frequency

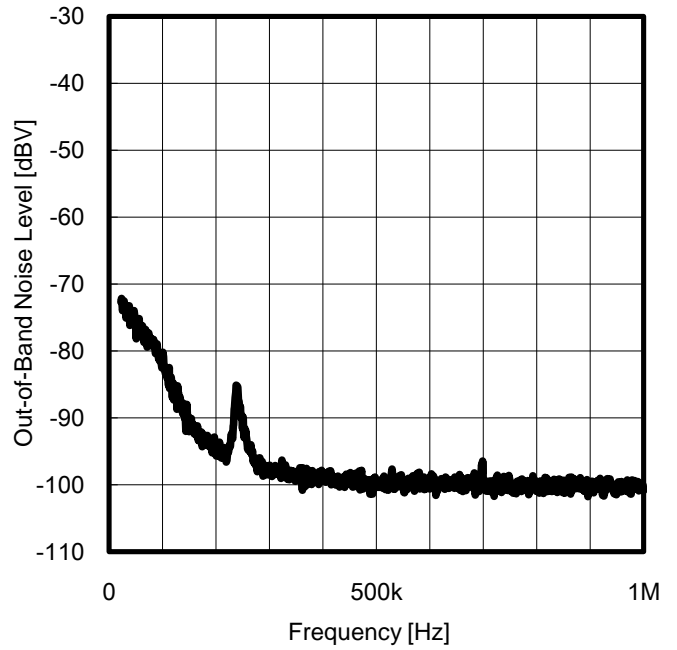

Figure 86. Out-of-Band Noise Level vs Frequency

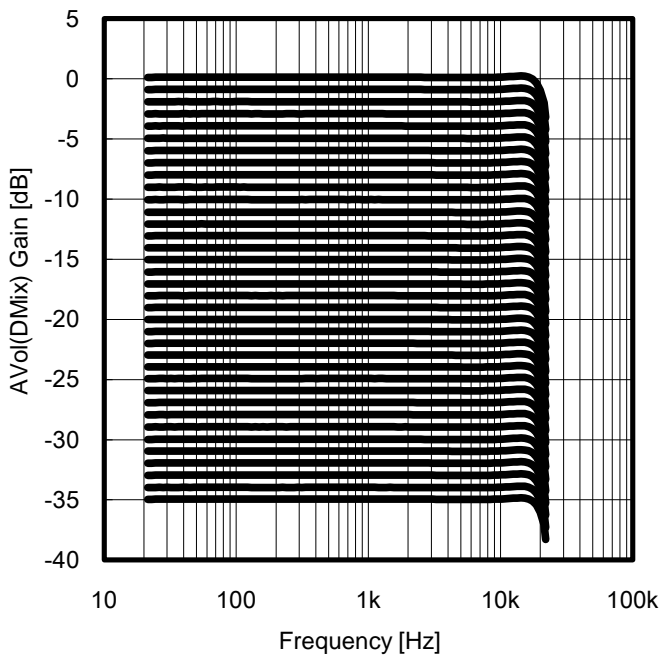

Figure 87. AVol(DMix) Gain vs Frequency
(Gain=0dB to -35dB/1dB step)

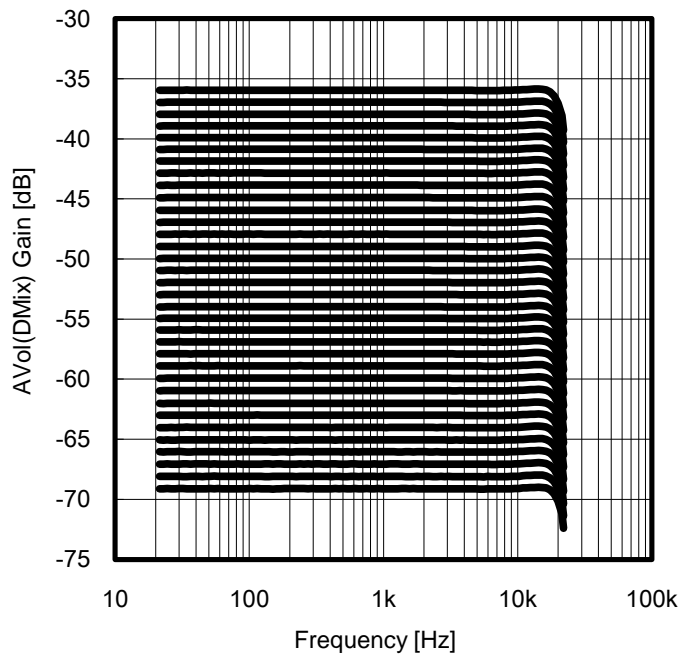

Figure 88. AVol(DMix) Gain vs Frequency
(Gain=-36dB to -69dB/1dB step)

Typical Performance Curves - Continued

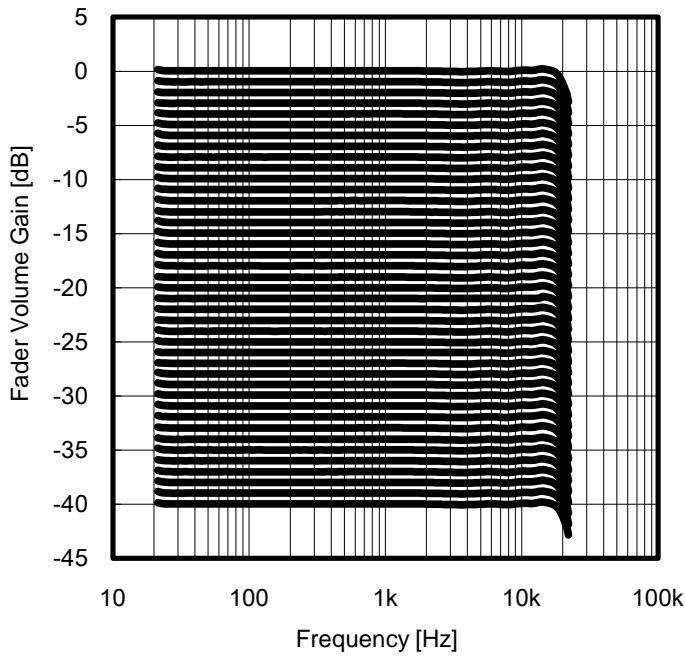

Figure 89. Fader Volume Gain vs Frequency (Gain=0dB to -40dB/1dB step)

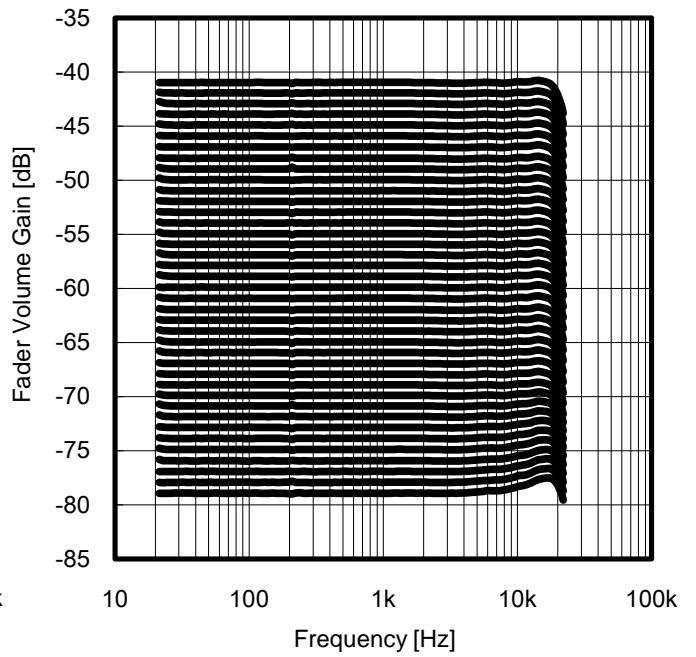

Figure 90. Fader Volume Gain vs Frequency (Gain=-41dB to -79dB/1dB step)

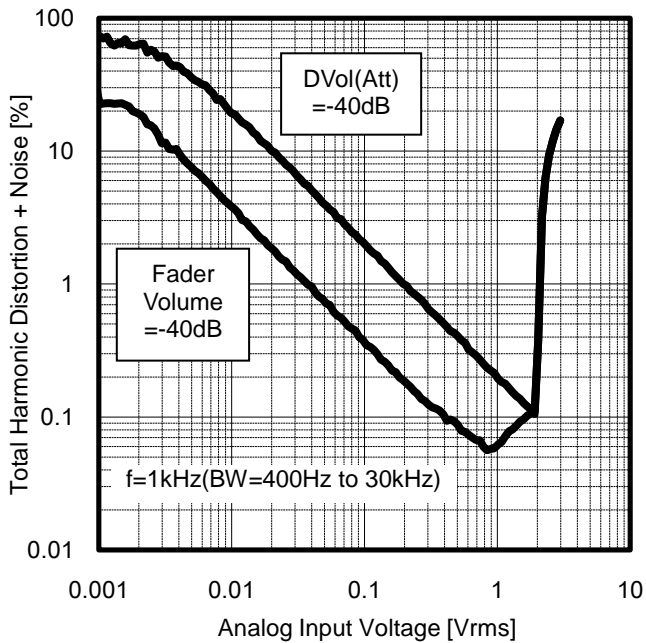

Figure 91. Total Harmonic Distortion + Noise vs Analog Input Voltage (Analog Input Selector-ADC-DAC-Fader Volume-Analog Output)

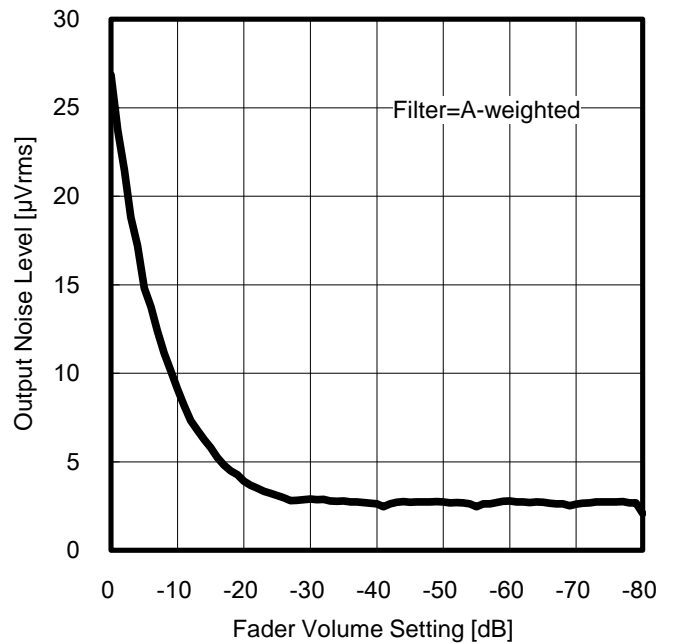

Figure 92. Output Noise Level vs Fader Volume setting (Analog Input Selector-ADC-DAC-Fader Volume-Analog Output)

Typical Performance Curves - Continued

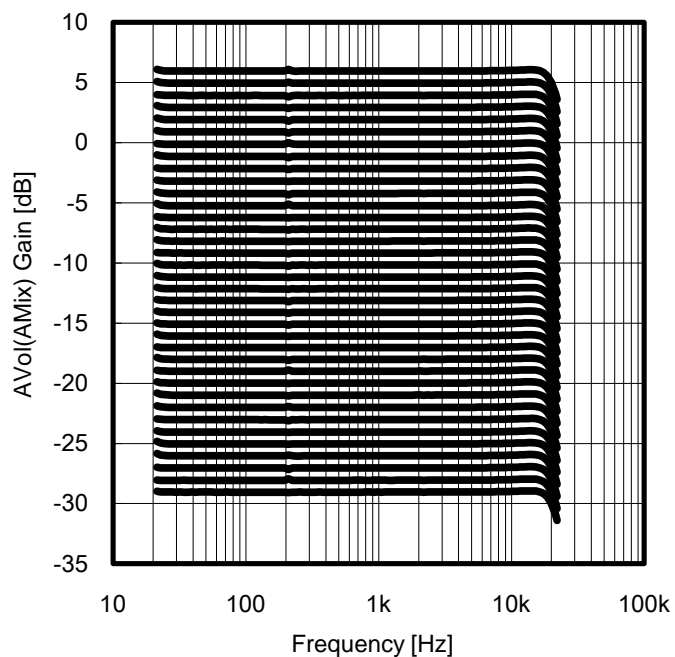

Figure 93. AVol(AMix) Gain vs Frequency
(Gain=+6dB to -29dB/1dB step)

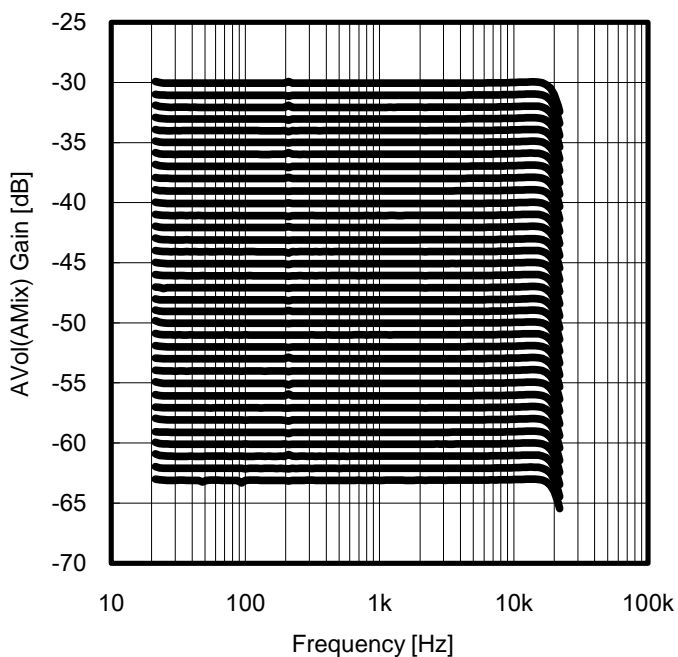

Figure 94. AVol(AMix) Gain vs Frequency
(Gain=-30dB to -63dB/1dB step)

3 Wires Serial Audio Data Format & Master Clock Specification

Data format can be in I²S method, Left-Justified method or Right-Justified method. Also, input(or output) can be in 16bit, 20bit or 24bit. Digital Input1 and Digital Input3 are SRC correspondences and their f_S can be in 8k/16k/24k/32k/44.1k/48k/88.2k/96kHz. The S/PDIF input is also supported in f_S=16kHz to 96kHz. (Except for the characteristic of interface. The characteristic of interface is compliant with the [Electrical Characteristic of Digital System](#).)

It is recommended that f_S error is within ±5% from 8k/16k/24k/32k/44.1k/48k/88.2k/96kHz.

Digital Output1, Digital Output3 and Digital ExtIO(Output2 & Input2) are set only to 44.1kHz/48kHz which is synchronized with MCK.

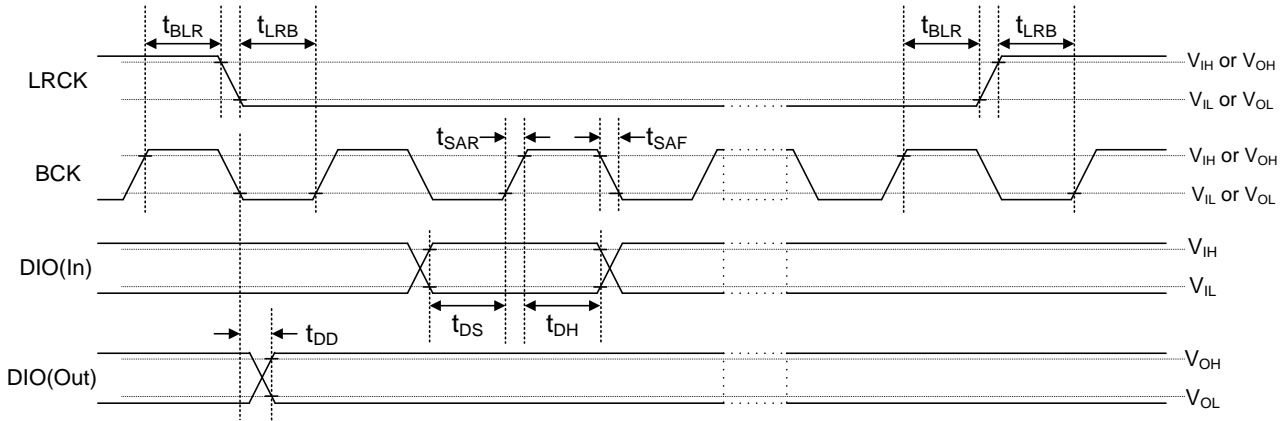

Figure 95. Serial Audio Data Timing Chart

Unless otherwise noted AVDD*(Note 1)=5.8V, DVDD*(Note 2)=3.3V, Ta=25°C, CL=20pF, MCK=384 x f_S(f_S=44.1kHz/48kHz)

Parameter	Symbol	f _S (kHz)	Limit			Unit
			Min	Typ	Max	
MCK(Master Clock) Frequency 256f _S or 384f _S or 512f _S	f _{MCK256}	44.1	10.8380	11.2896	11.7412	MHz
		48	11.7965	12.2880	12.7795	
	f _{MCK384}	44.1	16.2570	16.9344	17.6118	
		48	17.6947	18.4320	19.1693	
	f _{MCK512}	44.1	21.6760	22.5792	23.4824	
		48	23.5930	24.5760	25.5590	
MCK(Master Clock) Duty Rate	Dut _{MCK}	-	40	50	60	%
BCK Clock Frequency	f _{BCK}	44.1	2.7095	2.8224	2.9353	MHz
		48	2.9491	3.0720	3.1949	
BCK Duty Rate	Dut _{BCK}	Input	45	-	55	%
		Output	-	50	-	
Edge of LRCK from Rise Time of BCK	t _{BLR}	-	20	-	-	ns
Rise Time of BCK from Edge of LRCK	t _{LRB}	-	20	-	-	
Setup Time of DIO(In)	t _{DS}	-	20	-	-	
Hold Time of DIO(In)	t _{DH}	-	20	-	-	
Rise Time of LRCK, BCK and DIO(In)	t _{SAR}	-	-	-	10	
Fall Time of LRCK, BCK and DIO(In)	t _{SAF}	-	-	-	10	
Output Alignment Time of DIO(Out)	t _{DD}	-	-	-	50	
Input Voltage	High Level	V _{IH}	-	2.4	-	
	Low Level	V _{IL}	-	-	0.8	
Output Voltage	High Level	V _{OH}	-	2.75	-	
	Low Level	V _{OL}	-	-	0.55	

(Note 1) AVDD*=AVDDL1, AVDDL2, AVDDR1, AVDDR2

(Note 2) DVDD*=DVDD1, DVDD2

3 Wires Serial Audio Data Format & Master Clock Specification - Continued

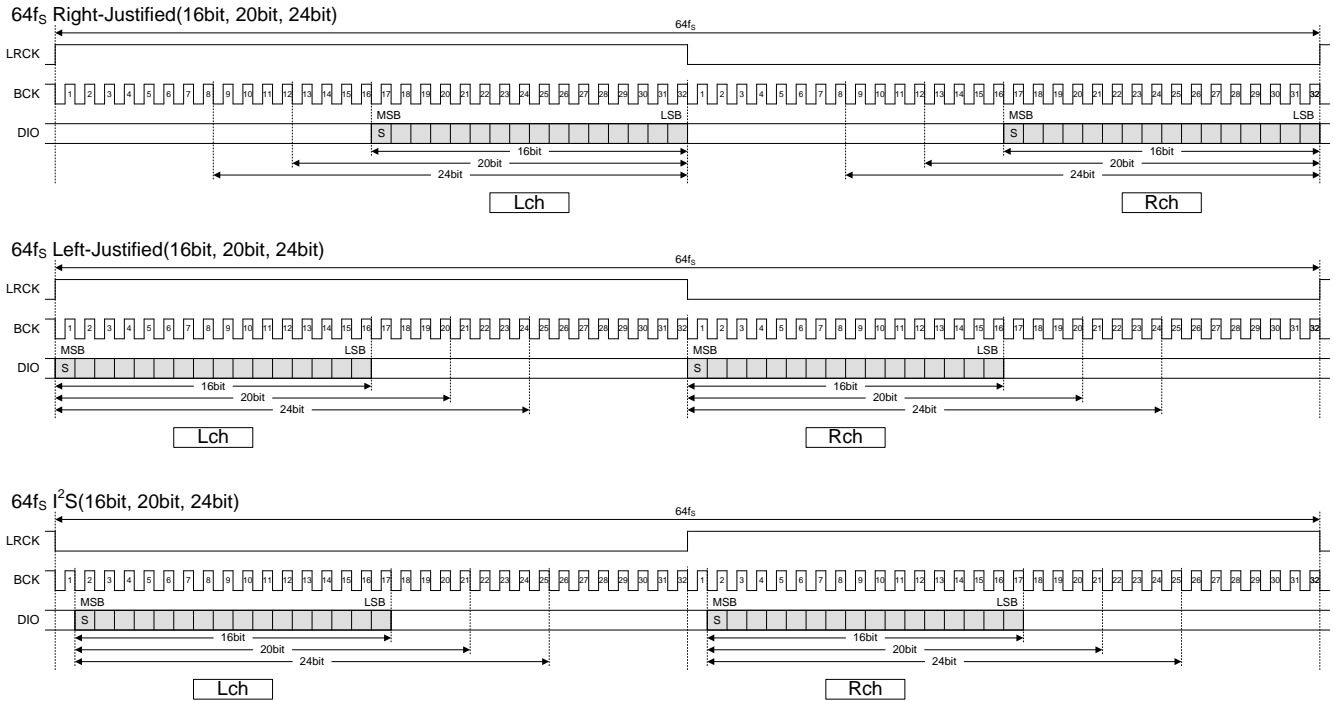

Figure 96. Serial Audio Data Format

- The data is read at rising edge of BCK.

S/PDIF Specification

Timing of S/PDIF Data

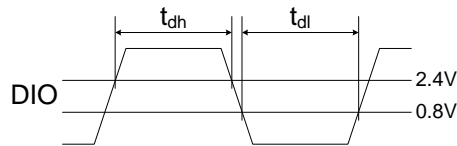

Figure 97. S/PDIF Data Timing Chart

Unless otherwise noted AVDD*(Note 1)=5.8V, DVDD*(Note 2)=3.3V, Ta=25°C, UI=(1/fs)/128(162.72ns)

Parameter	Symbol	Limit			Unit
		Min	Typ	Max	
DIO High time	t_{dh}	0.8	-	-	UI
DIO Low time	t_{dl}	0.8	-	-	

(Note 1) AVDD*=AVDDL1, AVDDL2, AVDDR1, AVDDR2

(Note 2) DVDD*=DVDD1, DVDD2

4 Wires(SPI) Control Signal Specification

(1) 4-Wire Serial Control Signal Line Timing

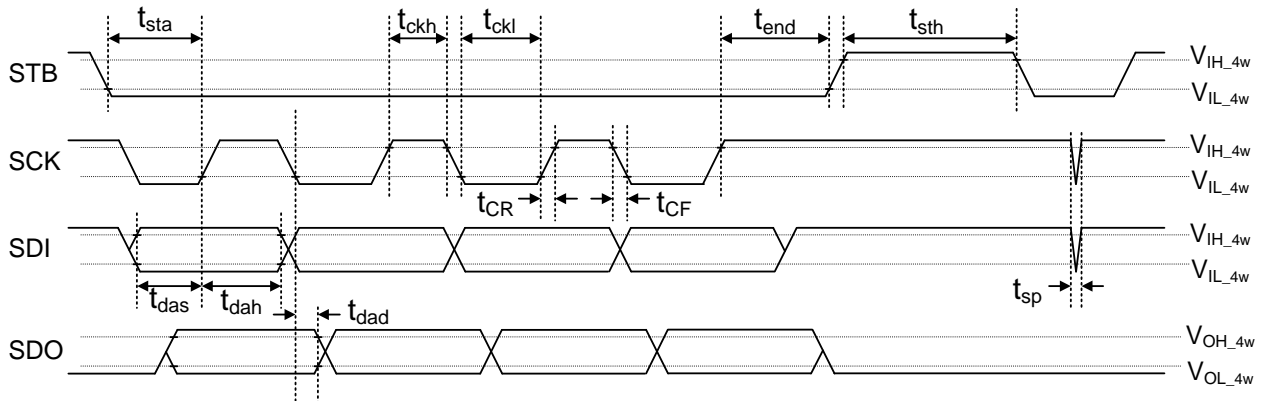

Figure 98. Control Signal Timing Chart

Unless otherwise noted AVDD*(Note 1)=5.8V, DVDD*(Note 2)=3.3V, Ta=25°C, MCK=384 x f_S(f_S=44.1kHz/48kHz)

Parameter		Symbol	Limit		Unit
			Min	Max	
SCK Clock Frequency		f _{sck}	10	800k	Hz
Rise Time of SCK from Fall of STB		t _{sta}	400	-	ns
Rise Time of SCK from Rise of STB		t _{end}	400	-	
High Period of STB		t _{sth}	200	-	
High Period of SCK		t _{ckh}	200	-	
Low Period of SCK		t _{ckl}	200	-	
Setup Time of SDI		t _{das}	100	-	
Hold Time of SDI		t _{dah}	100	-	
Rise Time of STB, SCK and SDI		t _{CR}	-	100	
Fall Time of STB, SCK and SDI		t _{CF}	-	100	
Input Filter Controlled Spike Pulse Width		t _{sp}	0	50	
Output Delay Time of SDO		t _{dad}	-	(4/MCK)+60	
Input Voltage	High Level	V _{IH_4w}	2.4	-	
	Low Level	V _{IL_4w}	-	0.8	
Output Voltage	High Level	V _{OH_4w}	2.75	-	
	Low Level	V _{OL_4w}	-	0.55	

(Note 1) AVDD*=AVDDL1, AVDDL2, AVDDR1, AVDDR2

(Note 2) DVDD*=DVDD1, DVDD2

4 Wires(SPI) Control Signal Specification - Continued

(2) 4-Wires Serial Control Signal Format

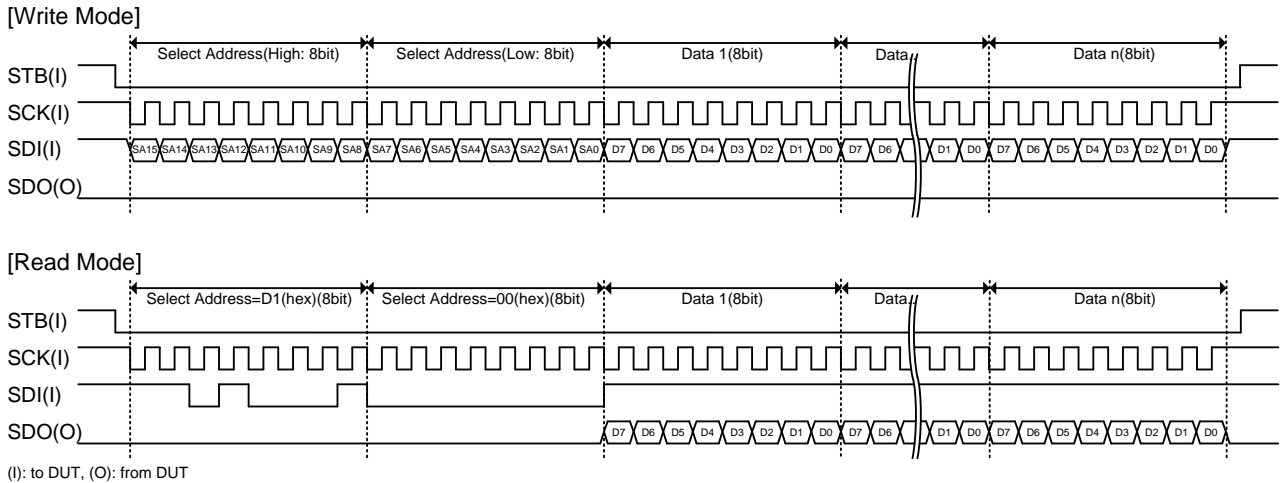

It will become read mode if Select Address=D100(hex) is specified. The address for read-out serves as a value written in Select Address=D000(hex) to D001(hex).

Figure 99. Control Signal Format

[Write Mode]

- The command data is written during the SCK rising edge.
- Be sure to set STB back to High after data transmission ends. Serial-Parallel Conversion is performed with 16bits from fall of STB as a Select Address and bits following it as data.
- It is recommended that SCK and SDI are set to High after data transmission in order to avoid error caused by noise.
- The auto increment internal function is built-in. Auto increment is a transfer format in which data is set continuously to the Address as described above. Every time data is transmitted by 8bits, the Select Address is incremented.

[Read Mode]

The following procedures perform read back of a register.

- The “read-out start Address” is sent to the Select Address D000(hex) to D001(hex) in Write Mode.
- By sending the Select Address D100(hex), the read-out is started from the “read-out start Address” written in the Select Address D000(hex) to D001(hex).
 Example. When the user selects 0200(hex) and read back 5bytes, each byte is for the register value of Address 0200(hex) to 0204(hex).
- 2bytes data of the Read Only register(Address A000(hex) to A01F(hex)) should be read 2bytes continuously.
 It is recommended that 2bytes continuation read-out by the auto increment function is performed.
 Example. When you read SpeAna Level of Band9 (first 8bit: A010(hex), last 8bit: A011(hex)), Read Address A010(hex) at first and then read A011(hex).

2 Wires Control Signal Specification

(1) Electrical specifications and timing for bus lines and I/O stages

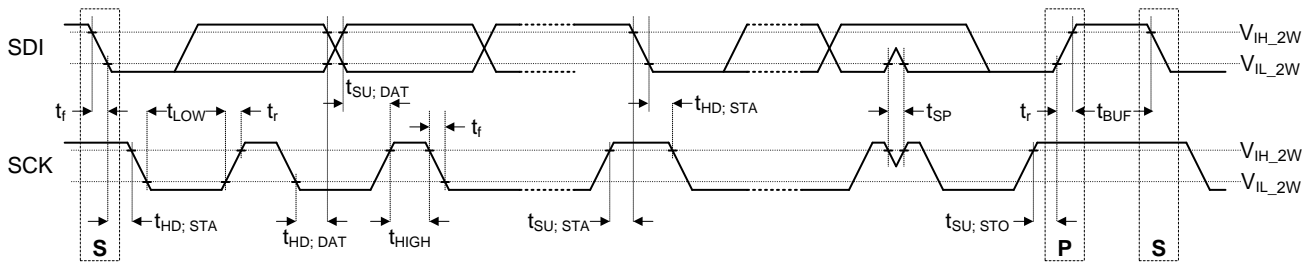

S: Start condition(Recognition of start bit)
 P: Stop condition(Recognition of stop bit)

*The STB pin connect to the DVDD2 pin. The SDO pin always outputs Low level.

Figure 100. Control Signal Timing Chart

Unless otherwise noted AVDD*(Note 1)=5.8V, DVDD*(Note 2)=3.3V, Ta=25°C, MCK=384 x f_S(f_S=44.1kHz/48kHz)

Parameter	Symbol	Limit		Unit
		Min	Max	
SCK Clock Frequency	f _{SCK}	10	400k	Hz
Hold Time(Repeated) Start Condition. After This Period, the First Clock Pulse is Generated	t _{HD; STA}	0.6	-	μs
Low Period of the SCK Clock	t _{LOW}	1.3	-	
High Period of the SCK Clock	t _{HIGH}	0.6	-	
Setup Time for a Repeated Start Condition	t _{SU; STA}	0.6	-	
Data Hold Time:	t _{HD; DAT}	0	-	
Data Setup Time	t _{SU; DAT}	2/MCK	-	
SDI, SCK Rise Time	t _r	-	100	
SDI, SCK Fall Time	t _f	-	100	
Setup Time for Stop Condition	t _{SU; STO}	0.6	-	
Bus Free Time Between a Stop and Start Condition	t _{BUF}	1.3	-	
Low Level Input Voltage: Fixed Input Levels	V _{IL_2W}	-0.5	+1	
High Level Input Voltage: Fixed Input Levels	V _{IH_2W}	2.3	-	
Low Level Output Voltage(Open Drain): at 3mA Sink Current	V _{OL1}	0	0.4	ns
Pulse width of spikes which must be suppressed by the input filter.	t _{SP}	0	1/MCK	

(Note 1) AVDD*=AVDDL1, AVDDL2, AVDDR1, AVDDR2

(Note 2) DVDD*=DVDD1, DVDD2

2 Wires Control Signal Specification - Continued

(2) BUS FORMAT

MSB	LSB	MSB	LSB	MSB	LSB	MSB	LSB		
S	Slave Address	A	Select Address High	A	Select Address Low	A	Data	A	P
1bit	8bit	1bit	8bit	1bit	8bit	1bit	8bit	1bit	1bit

- S = Start condition(Recognition of start bit)
- Slave Address = Recognition of Slave Address(Writing: 80(hex), Reading: 81(hex))
- A = ACKNOWLEDGE bit(Recognition of acknowledgement)
- Select Address High/Low = Select Address of item
- Data = Data of item
- P = Stop condition(Recognition of stop bit)

(3) Slave Address

Writing: 80(hex), Reading: 81(hex)

MSB							LSB
A6	A5	A4	A3	A2	A1	A0	R/W
1	0	0	0	0	0	0	1/0

(4) Writing of data

1) Basic format

S	80(hex)	A	Select Address High	A	Select Address Low	A	Data	A	P
1bit	8bit	1bit	8bit	1bit	8bit	1bit	8bit	1bit	1bit

: Master to Slave, : Slave to Master

2) Auto increment format(Normally, Select Address increases (+1) according to the number of data.)

S	80(hex)	A	Select Address High	A	Select Address Low	A	Data1	A	Data2	A	...	DataN	A	P
1bit	8bit	1bit	8bit	1bit	8bit	1bit	8bit	1bit	8bit	1bit	8bit	8bit	1bit	1bit

: Master to Slave, : Slave to Master

- Example.
1. Data1 shall be set as data of Address specified by Select Address.
 2. Data2 shall be set as data of Address specified by Select Address +1.
 3. DataN shall be set as data of Address specified by Select Address +N-1.

(5) Reading of data

Read Back Address: D000(hex)

First of all, the Select Address(0A00(hex) in the example) for reading is written in the register of the Read Back Address: D000(hex) when reading. In the next stream, data is read after the slave Address. Do not return the Acknowledge when you end the reception.

S	80(hex)	A	D0(hex)	A	00(hex)	A	Select Address High	A	Select Address Low	A	P
Example. 80(hex)			D0(hex)		00(hex)		0A(hex)		00(hex)		

S	81(hex)	A	Data1	A	Data2	A	...	A	DataN	Ā	P
Example. 81(hex)			**(hex)		**(hex)				**(hex)		

: Master to Slave, : Slave to Master, A : With Acknowledge, Ā : Without Acknowledge

Select Address & Data

Item	Select Address		Data								Initial Data (hex)	
	High (hex)	Low (hex)	D7	D6	D5	D4	D3	D2	D1	D0		
Initial Setup1	00	01	Data RAM Clear	Coef RAM Clear	MCK Selector		f _s Selector	1	0	0	D4	
Initial Setup2	00	02	X'over/EQ	P ² Bass	SL X'over	0	Loudness	0	0	0	00	
Initial Setup3	00	03	0	Advanced Switch time for Mixing Fader			0	Advanced Switch time for Fader Volume			00	
Initial Setup4	00	04	0	Advanced Switch time for Mixing			0	Advanced Switch time for AVol(AMix/DMix)			00	
Initial Setup5	00	05	Fader Volume Threshold Gain				Advanced Switch time for Fader Volume upper Gain				00	
Initial Setup6	00	06	0	Advanced Switch time for DVol(Boost)			0	Advanced Switch time for DVol(Att)/P ² Bass Gain/Loudness Gain			33	
Initial Setup7	00	07	Advanced Switch time for 3-Band Tone/HPF(Coef)/IIR A/IIR B		Advanced Switch time for 13-Band EQ(High)		Advanced Switch time for 13-Band EQ(Middle)		Advanced Switch time for 13-Band EQ(Low)		FF	
Initial Setup8	00	08	1	1	Advanced Switch time for Time Alignment		0	0	1	1	F3	
Digital Format1	00	10	0	0	BEEP I/F	0	BCK/LRCK direction(DIND)	BCK/LRCK direction(DINC)	BCK/LRCK direction(DINB)	BCK/LRCK direction(DINA)	0F	
Digital Format2	00	11	0	0	0	0	Digital IO Format(Input1)		Digital IO Bit Width(Input1)		00	
Digital Format3	00	12	0	0	0	0	Digital IO Format(Input3)		Digital IO Bit Width(Input3)		00	
Digital Format4	00	13	0	0	0	0	Digital IO Format(Output1)		Digital IO Bit Width(Output1)		00	
Digital Format5	00	14	0	0	S/PDIF Clock Accuracy (Output1)		0	0	S/PDIF Copyright (Output1)	S/PDIF Emphasis (Output1)	00	
Digital Format6	00	15	S/PDIF Category(Output1)								00	
Digital Format7	00	16	0	0	0	0	Digital IO Format(Output3)		Digital IO Bit Width(Output3)		00	
Digital Format8	00	17	0	0	S/PDIF Clock Accuracy (Output3)		0	0	S/PDIF Copyright (Output3)	S/PDIF Emphasis (Output3)	00	
Digital Format9	00	18	S/PDIF Category(Output3)								00	
Digital Format10	00	19	Rear Input Selector(ExtIO)	Sub Input Selector(ExtIO)	0	0	Digital IO Format(ExtIO)		Digital IO Bit Width(ExtIO)		00	
Sync Detection1 (Input1)	00	1A	MUTE during Sync Error	0	0	0	Audio frame counts for sync detection(Input1)				00	
Sync Detection2 (Input3)	00	1B	MUTE during Sync Error	0	0	0	Audio frame counts for sync detection(Input3)				00	
Sync Detection3 (ExtIO)	00	1C	MUTE during Sync Error	0	0	0	Audio frame counts for sync detection(ExtIO)				00	
Test A	00	1D	0	0	0	0	0	0	0	0	00	
Test B	00	1E	1	1	0	0	0	0	0	0	C0	
Test C	00	1F	0	0	0	0	0	0	0	0	00	
Test D	00	20	1	1	0	0	0	0	0	0	C0	
Test E	00	21	0	0	1	1	0	1	0	0	34	
Test F	00	22	0	0	0	0	0	1	0	1	05	
Input Gain	01	01	0	0	Input Gain						00	
Fader Input Selector	01	02	0	0	Sub Selector		0	0	Rear Selector		00	
Analog Input Selector	01	03	Select Mode	Analog Mixing Input Selector			0	Analog Input Selector			80	
Analog Mixing Selector1	01	04	Analog Mixing Source(FL)		Analog Mixing Source(FR)		Analog Mixing Source(RL)		Analog Mixing Source(RR)		00	
Analog Mixing Selector2	01	05	Stereo Mix Gain	0	0	0	Analog Mixing Source(SL)		Analog Mixing Source(SR)		00	
Analog Mixing Selector3	01	06	1	0	Analog Mixing(FL)	Analog Mixing(FR)	Analog Mixing(RL)	Analog Mixing(RR)	Analog Mixing(SL)	Analog Mixing(SR)	80	
AVol(AMix)(Lch)	01	07	1	AVol(AMix) Lch								80
AVol(AMix)(Rch)	01	08	1	AVol(AMix) Rch								80
Digital Mixing Selector	01	09	1	DAC Digital Mixing Mode	Digital Mixing(FL)	Digital Mixing(FR)	Digital Mixing(RL)	Digital Mixing(RR)	Digital Mixing(SL)	Digital Mixing(SR)	80	
AVol(DMix)	01	0A	1	AVol(DMix)								80
Digital IO Selector1	02	00	0	0	0	0	0	0	Digital ExtIO IO Selector		00	
Digital IO Selector2	02	01	0	Digital Output3 IO Selector				0	Digital Output1 IO Selector			00
Digital IO Selector3	02	02	Digital Input3 IO Selector				Digital Input1 IO Selector				00	
DSP Selector1	02	03	DSP Input Selector	Loudness Input Selector	SpeAna Input Selector	Time Alignment Input Selector	Time Alignment Mode	0	0	0	00	
DSP Selector2	02	04	0	0	0	0	0	Noise Selector	0	Noise Gen	00	
DSP Selector3	02	05	0	P ² Bass Input Selector(Front)	P ² Bass Input Selector(Rear)		0	1	0	1	00	
DSP Selector4	02	06	SL X'over Input Selector		SR Volume Input Selector		0	0	Digital Mixing Stereo Mix	Digital Mixing Input Selector	00	
DSP Selector5	02	07	0	0	Digital Output1 Sub Selector		Digital Output1 Rear Selector		Digital Output1 Front Selector		00	
DSP Selector6	02	08	0	0	Digital Output3 Selector		0	0	Digital Output2 Selector		00	

Advanced Switch available

Do not send the data that are not designated in above table.

Select Address & Data - Continued

Item	Select Address		MSB							Data			LSB		Initial Data (hex)
	High (hex)	Low (hex)	D7	D6	D5	D4	D3	D2	D1	D0					
Time Alignment1(FL)	04	00	0	0	0	0	0	0	Time Alignment Time FL[9:8]			00			
Time Alignment2(FL)	04	01	Time Alignment Time FL[7:0]										00		
Time Alignment3(FR)	04	02	0	0	0	0	0	0	Time Alignment Time FR[9:8]			00			
Time Alignment4(FR)	04	03	Time Alignment Time FR[7:0]										00		
Time Alignment5(RL)	04	04	0	0	0	0	0	0	Time Alignment Time RL[9:8]			00			
Time Alignment6(RL)	04	05	Time Alignment Time RL[7:0]										00		
Time Alignment7(RR)	04	06	0	0	0	0	0	0	Time Alignment Time RR[9:8]			00			
Time Alignment8(RR)	04	07	Time Alignment Time RR[7:0]										00		
Time Alignment9(S)	04	08	0	0	0	0	0	0	Time Alignment Time S[9:8]			00			
Time Alignment10(S)	04	09	Time Alignment Time S[7:0]										00		
Time Alignment11(RL2)	04	0A	0	0	0	0	0	0	Time Alignment Time RL2[9:8]			00			
Time Alignment12(RL2)	04	0B	Time Alignment Time RL2[7:0]										00		
Time Alignment13(RR2)	04	0C	0	0	0	0	0	0	Time Alignment Time RR2[9:8]			00			
Time Alignment14(RR2)	04	0D	Time Alignment Time RR2[7:0]										00		
Spectrum Analyzer1	05	00	Spectrum Analyzer Type		Spectrum Analyzer Input Selector		0	1	BPF Q			04			
Spectrum Analyzer2	05	01	0	0	0	Spectrum Analyzer Gain						00			
EQ Mode/Scaler	06	00	EQ Mode	PreScaler(Front/Rear)			0	PostScaler(Front/Rear)				00			
13-Band EQ(Front)	06	10-1C	Direct Coef Set	Ch Selector	EQ Q	EQ Gain Boost/Cut	EQ Gain					00			
3-Band Tone Bass(Front)	06	1D	Direct Coef Set	Ch Selector	Bass f _c		Bass Gain Boost/Cut	Bass Gain				00			
3-Band Tone Middle(Front)	06	1E	Direct Coef Set	Ch Selector	Middle f ₀		Middle Gain Boost/Cut	Middle Gain				00			
3-Band Tone Treble(Front)	06	1F	Direct Coef Set	Ch Selector	Treble f _c		Treble Gain Boost/Cut	Treble Gain				00			
3-Band EQ Band A, B, C(Front)	06	1D-1F	Direct Coef Set	Ch Selector	EQ Q	EQ Gain Boost/Cut	EQ Gain					00			
13-Band EQ(Rear)	06	20-2C	0	0	EQ Q	EQ Gain Boost/Cut	EQ Gain					00			
3-Band Tone Bass(Rear)	06	2D	0	0	Bass f _c		Bass Gain Boost/Cut	Bass Gain				00			
3-Band Tone Middle(Rear)	06	2E	0	0	Middle f ₀		Middle Gain Boost/Cut	Middle Gain				00			
3-Band Tone Treble(Rear)	06	2F	0	0	Treble f _c		Treble Gain Boost/Cut	Treble Gain				00			
3-Band EQ Band A, B, C(Rear)	06	2D-2F	0	0	EQ Q	EQ Gain Boost/Cut	EQ Gain					00			
DC Cut HPF /De-emphasis	07	00	De-emphasis Front/Rear(DAC)	0	0	0	DC Cut HPF (ADC)	DC Cut HPF (Input3)	DC Cut HPF (Input2)	DC Cut HPF (Input1)	00				
Loudness Filter	07	01	Direct Coef Set	Loudness HPF f _c			0	Loudness LPF f _c				00			
Loudness Gain	07	02	1	0	Loudness HiBoost		Loudness Gain					80			
Front HPF	07	03	Direct Coef Set	Front HPF Phase	Front HPF Order	0	Front HPF f _c					00			
Rear HPF	07	04	0	Rear HPF Phase	Rear HPF Order	0	Rear HPF f _c					00			
P ² Bass(Front)	07	05	1	P ² Bass f _c (Front)			P ² Bass Gain(Front)					80			
P ² Bass(Rear)	07	06	1	P ² Bass f _c (Rear)			P ² Bass Gain(Rear)					80			
Sub LPF	07	07	Direct Coef Set	Sub LPF Phase	0	Sub LPF Order	Sub LPF f _c					00			
Sub HPF	07	08	Direct Coef Set	0	0	0	Sub HPF f _c					00			
IIR	07	09	Direct Coef Set (IIR A/IIR B)	Direct Coef Set (Sub IIR)	0	0	0	0	0	0	00				
BEEP1	08	00	BEEP Level									00			
BEEP2	08	01	BEEP Mode	BEEP Repeat			BEEP Type	BEEP Frequency				00			
BEEP3	08	02	BEEP OFF time				BEEP ON time					00			
BEEP4	08	03	0	Direct Coef Set(OFF time)	Direct Coef Set(ON time)	Direct Coef Set(f _c)	BEEP Fade-IN	BEEP Fade-OUT	0	BEEP Trigger	00				
Test1	08	04	0	0	0	0	0	0	0	0					
DVol(Output2)(L/R)	08	05	DVol(Output2)(L/R)									00			
DVol(Att) (FL/FR/RL/RR/SL/SR)	09	00-05	DVol(Att)									00			
DVol(Boost) (FL/FR/RL/RR/SL/SR)	09	06-0B	DVol(Boost)									00			
Fader Volume (FL/FR/RL/RR/SL/SR)	0A	00-05	1	Fader Volume								80			
EQ/Tone Coef Selector	10	00	0	EQ/Tone Ch Selector			EQ/Tone Band Selector					00			
EQ/Tone Coef	10	01-14	32bit-coefficients(b0, b1, b2, a1, a2)									00			
(Front/Rear)HPF(A/B) /IIR(A/B) Coef Selector	11	00	0	0	0	0	0	IIR Selector				00			
(Front/Rear)HPF(A/B) /IIR(A/B) Coef	11	01-14	32bit-coefficients(b0, b1, b2, a1, a2)									00			
Loudness Coef Selector	12	00	0	0	0	0	0	0	0	Filter Selector	00				
Loudness Coef	12	01-0F	LPF/HPF 24bit-coefficients(b0, b1, b2, a1, a2)									00			
Loudness HiBoost Coef	12	11-12	HiBoost 16bit-coefficients(HiBoost)									00			
Loudness Gain Coef	12	13-14	Gain 16bit-coefficients(Gain)									00			

Advanced Switch available

Do not send the data that are not designated in above table.

Select Address & Data - Continued

Item	Select Address		MSB				Data				LSB		Initial Data (hex)
	High (hex)	Low (hex)	D7	D6	D5	D4	D3	D2	D1	D0			
Sub IIR Coef Selector	13	00	0	0	0	0	0	IIR Selector			00		
Sub IIR Coef	13	01-14	32bit-coefficients(b0, b1, b2, a1, a2)									00	
BEEP Coef	14	00-05	24bit-coefficients(b1, a1)									00	
BEEP ON time Coef1	14	06	0	0	0	0	0	0	18bit-coef ON time[17:16]			00	
BEEP ON time Coef2	14	07-08	18bit-coefficient ON time[15:0]									00	
BEEP OFF time Coef1	14	09	0	0	0	0	0	0	18bit-coef OFF time[17:16]			00	
BEEP OFF time Coef2	14	0A-0B	18bit-coefficient OFF time[15:0]									00	
EQ/Tone Coef Read back Setting	15	00	0	0	EQ/Tone Ch Selector		EQ/Tone Band Selector				00		
IIR Coef Read back Setting	15	01	0	Sub IIR Selector			Loudness Filter Selector	(Front/Rear)HPF/IIR(A/B) Selector				00	
Spectrum Analyzer Status #	A0	00-1F	Output Level									#	
S/PDIF Status1(Input1) #	A0	40	0	0	0	0	Application	Format	Copyright	Emphasis	#		
S/PDIF Status2(Input1) #	A0	41	Category									#	
S/PDIF Status3(Input1) #	A0	42	Original Sampling Frequency				Sampling Frequency				#		
S/PDIF Status4(Input1) #	A0	43	0	0	Clock Accuracy		Word Length				#		
S/PDIF Status1(Input3) #	A0	44	0	0	0	0	Application	Format	Copyright	Emphasis	#		
S/PDIF Status2(Input3) #	A0	45	Category									#	
S/PDIF Status3(Input3) #	A0	46	Original Sampling Frequency				Sampling Frequency				#		
S/PDIF Status4(Input3) #	A0	47	0	0	Clock Accuracy		Word Length				#		
Sync Status #	A0	51	0	0	0	0	0	Sync(Input1)	Sync(ExtIO)	Sync(Input3)	#		
Coef IO Status #	A0	53	0	0	0	0	EQ	Loudness Filter	Front/Rear/A/B	Sub	#		
Read Back Address1, 2	D0	00, 01	Base Address(High), (Low)									#	
System Reset	FE	FE	System Reset									00	

Advanced Switch(Advanced Switch available)

#: Read-Only
Do not send the data that are not designated in above table.

Note

1. An Advanced Switch operation when switching functions is available in shaded region. Functions in which Advanced Switch operation is not available have no countermeasure against pop noise. Therefore, when the setting in these is changed, take countermeasures, such as setting sound MUTE in the product.
2. The data of each Select Address is supported for both read/write modes(Some addresses are Read Only). When the data is continuously transferred, the Select Address circulates by auto increment function, as described below.

[Normal Addresses](hex)

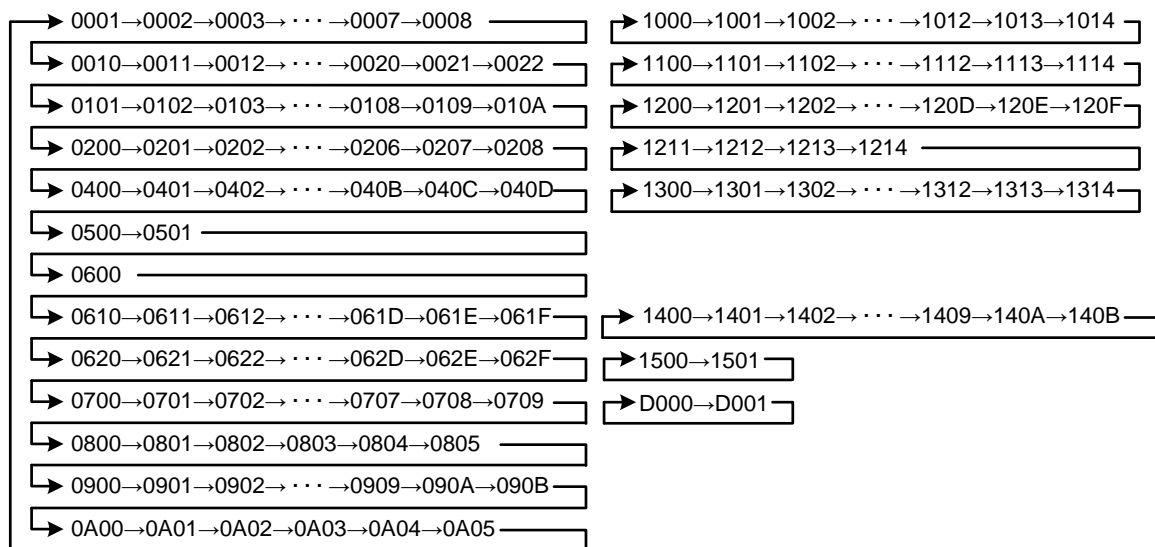

(Select Address: 0001 to 0A05, these addresses must be sent always.)

[Read Only Addresses](hex)

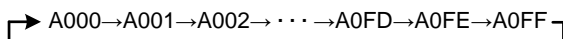

Select Address & Data - Continued

3. In DSP part, it is necessary to clear RAMs during initialization. RAM initialization is executed by "RAM Clear" command (Address 0001(hex)). Data RAM(ADC, DAC, SRC and DSP) are cleared by "Data RAM Clear(D7)" command. Coefficient RAM(Loudness, EQ, X'over and IIR) are cleared by "Coef RAM Clear(D6)" command. Furthermore, during the RAM clear process, there is no countermeasure against pop noise.
4. The logic circuit reset can be activated from the command(System Reset). Furthermore, after the transmission of the "System Reset" command, reset will be cancelled automatically.
5. Below is recommended procedure for initialization and shutdown sequence.

<Initialization>

- (1) Send RESET("System Reset" command).
- (2) Send Initial Setup.
Do not change the "Data/Coef RAM Clear"(Select Address 0001(hex)[7:6]) register value from "Clear".
- (3) Send "Data/Coef RAM Clear".
Set the "Data/Coef RAM Clear"(Select Address 0001(hex)[7:6]) register value to "Normal".
- (4) Send all data without Fader Volume.
- (5) Send all Fader Volume.

<Shutdown>

- (1) Send Fader Volume $-\infty$ dB data(Address 0A00(hex) to 0A05(hex)).
- (2) Send RESET(After Fader Volume= $-\infty$ dB).

At supply voltage on, send System Reset and data to all Address as initial data and sound MUTE at set side until this initial data is sent.

Command Specification

 Initial Condition, 1/0 Fixed value Do not send the data not designated.

Select Address 0001(hex)

Function Name	Setting	MSB					Initial Setup1			LSB	
		D7	D6	D5	D4	D3	D2	D1	D0		
f _s Selector [3]	44.1kHz					0	1	0	0		
	48kHz					1					
MCK Selector [5:4]	256f _s			0	0						
	384f _s			0	1						
	512f _s			1	0						
	Prohibited			1	1						
Coef RAM Clear [6]	Normal		0								
	Clear		1								
Data RAM Clear [7]	Normal	0									
	Clear	1									

D6: After executing RAM Clear, all filters have to be setup again.

D4/D3: Change the setting only at initial setup.

D3: Some items, such as soft transition time are changed by the f_s setting. The changing item lists a value of f_s=44.1kHz and f_s=48kHz. All values for time and fc settings are the values by typical MCK frequency. These values are influenced by MCK frequency differences between typical and real.

Example. Real transition time=setup transition time x (typical MCK frequency/real MCK frequency)

Select Address 0002(hex)

Function Name	Setting	MSB					Initial Setup2			LSB	
		D7	D6	D5	D4	D3	D2	D1	D0		
Loudness [3]	Use					0	0	0	0		
	Bypass					1					
SL X'over [5]	Use			0	0						
	Bypass			1							
P ² Bass [6]	Use		0								
	Bypass		1								
X'over/EQ [7]	Use	0									
	Bypass	1									

Select Address 0003(hex)

Function Name	Setting		MSB					Initial Setup3			LSB	
	f _s =48kHz	f _s =44.1kHz	D7	D6	D5	D4	D3	D2	D1	D0		
Advanced Switch time for Fader Volume [2:0]	0.7ms/dB	0.8ms/dB	0				0	0	0	0		
	1.3ms/dB	1.4ms/dB						0	0	1		
	2.0ms/dB	2.2ms/dB						0	1	0		
	2.3ms/dB	2.5ms/dB						0	1	1		
	2.7ms/dB	2.9ms/dB						1	0	0		
	3.3ms/dB	3.6ms/dB						1	0	1		
	4.0ms/dB	4.4ms/dB						1	1	0		
	5.3ms/dB	5.8ms/dB						1	1	1		
Advanced Switch time for Mixing Fader [6:4]	2.0ms	2.2ms	0				0	0	0	0		
	4.0ms	4.4ms						0	0	1		
	8.0ms	8.7ms						0	1	0		
	10.0ms	10.9ms						0	1	1		
	12.0ms	13.1ms						1	0	0		
	14.0ms	15.2ms						1	0	1		
	17.0ms	18.5ms						1	1	0		
	20.0ms	21.8ms						1	1	1		

Refer to [“Fader Volume Advanced Switch”](#), [“Mixing Advanced Switch”](#) about Advanced Switch.

Do not send Advanced Switch time for Fader Volume data during Fader Volume Advanced Switch operation.

Pop noise may occur.

Do not send Advanced Switch time for Mixing Fader data during Mixing Fader Advanced Switch operation.

Fader Volume may malfunction.

Command Specification - Continued

Select Address 0004(hex)

Function Name	Setting		MSB				Initial Setup4				LSB
	f _s =48kHz	f _s =44.1kHz	D7	D6	D5	D4	D3	D2	D1	D0	
Advanced Switch time for AVol(AMix/DMix) [2:0]	0.7ms/dB	0.8ms/dB	0				0	0	0	0	
	1.3ms/dB	1.4ms/dB						0	0	1	
	2.0ms/dB	2.2ms/dB						0	1	0	
	2.3ms/dB	2.5ms/dB						0	1	1	
	2.7ms/dB	2.9ms/dB						1	0	0	
	3.3ms/dB	3.6ms/dB						1	0	1	
	4.0ms/dB	4.4ms/dB						1	1	0	
	5.3ms/dB	5.8ms/dB						1	1	1	
Advanced Switch time for Mixing [6:4]	2.0ms	2.2ms	0	0	0	0	0				
	4.0ms	4.4ms		0	0	1					
	8.0ms	8.7ms		0	1	0					
	10.0ms	10.9ms		0	1	1					
	12.0ms	13.1ms		1	0	0					
	14.0ms	15.2ms		1	0	1					
	17.0ms	18.5ms		1	1	0					
	20.0ms	21.8ms		1	1	1					

Refer to "Mixing Advanced Switch", "Advanced Switch" about Advanced Switch.
 Do not send Advanced Switch time for Mixing data during Mixing Advanced Switch operation.
 Fader Volume may malfunction.

Select Address 0005(hex)

Function Name	Setting		MSB				Initial Setup5				LSB
	f _s =48kHz	f _s =44.1kHz	D7	D6	D5	D4	D3	D2	D1	D0	
Advanced Switch time for Fader Volume upper Gain [3:0]	0.7ms/dB	0.8ms/dB					0	0	0	0	
	1.3ms/dB	1.4ms/dB					0	0	0	1	
	2.0ms/dB	2.2ms/dB					0	0	1	0	
	2.3ms/dB	2.5ms/dB					0	0	1	1	
	2.7ms/dB	2.9ms/dB					0	1	0	0	
	3.3ms/dB	3.6ms/dB					0	1	0	1	
	4.0ms/dB	4.4ms/dB					0	1	1	0	
	5.3ms/dB	5.8ms/dB					0	1	1	1	
	6.7ms/dB	7.3ms/dB					1	0	0	0	
	8.0ms/dB	8.7ms/dB					1	0	0	1	
	9.3ms/dB	10.1ms/dB					1	0	1	0	
	11.3ms/dB	12.3ms/dB					1	0	1	1	
	13.3ms/dB	14.5ms/dB					1	1	0	0	
	16.7ms/dB	18.2ms/dB					1	1	0	1	
	20.0ms/dB	21.8ms/dB					1	1	1	0	
23.3ms/dB	25.4ms/dB	1	1	1	1						
Fader Volume Threshold Gain [7:4]	OFF		0	0	0	0					
	-4dB		0	0	0	1					
	-5dB		0	0	1	0					
	-6dB		0	0	1	1					
	-7dB		0	1	0	0					
	-8dB		0	1	0	1					
	-9dB		0	1	1	0					
	-10dB		0	1	1	1					
	-11dB		1	0	0	0					
	-12dB		1	0	0	1					
	-13dB		1	0	1	0					
	-14dB		1	0	1	1					
	-15dB		1	1	0	0					
-16dB		1	1	0	1						
-17dB		1	1	1	0						
-18dB		1	1	1	1						

Refer to "Fader Volume Advanced Switch" about Fader Volume upper Gain, Fader Volume Threshold Gain.
 Do not send Advanced Switch time for Fader Volume upper Gain, Fader Volume Threshold Gain, during Fader Volume Advanced Switch operation. Pop noise may occur.

Command Specification - Continued

Select Address 0006(hex)

Function Name	Setting		MSB Initial Setup6 LSB							
	f _s =48kHz	f _s =44.1kHz	D7	D6	D5	D4	D3	D2	D1	D0
Advanced Switch time for DVol(Att)/ P ² Bass Gain/ Loudness Gain [2:0]	3.6ms/FullScale	3.9ms/FullScale	0				0	0	0	0
	7.1ms/FullScale	7.7ms/FullScale						0	0	1
	14.2ms/FullScale	15.5ms/FullScale						0	1	0
	28.4ms/FullScale	30.9ms/FullScale						0	1	1
	56.9ms/FullScale	61.9ms/FullScale						1	0	0
	113.8ms/FullScale	123.9ms/FullScale						1	0	1
	227.6ms/FullScale	247.7ms/FullScale						1	1	0
	455.1ms/FullScale	495.3ms/FullScale						1	1	1
Advanced Switch time for DVol(Boost) [6:4]	3.6ms/FullScale	3.9ms/FullScale	0	0	0					
	7.1ms/FullScale	7.7ms/FullScale	0	0	1					
	14.2ms/FullScale	15.5ms/FullScale	0	1	0					
	28.4ms/FullScale	30.9ms/FullScale	0	1	1					
	56.9ms/FullScale	61.9ms/FullScale	1	0	0					
	113.8ms/FullScale	123.9ms/FullScale	1	0	1					
	227.6ms/FullScale	247.7ms/FullScale	1	1	0					
	455.1ms/FullScale	495.3ms/FullScale	1	1	1					

Refer to "Advanced Switch" about Advanced Switch.

Select Address 0007(hex)

Function Name	Setting		MSB Initial Setup7 LSB							
	f _s =48kHz	f _s =44.1kHz	D7	D6	D5	D4	D3	D2	D1	D0
Advanced Switch time for 13-Band EQ(Low) [1:0]	5.4ms	5.9ms							0	0
	10.7ms	11.6ms							0	1
	21.4ms	23.3ms							1	0
	42.8ms	46.6ms							1	1
Advanced Switch time for 13-Band EQ(Middle) [3:2]	2.8ms	3.0ms						0	0	
	5.4ms	5.9ms						0	1	
	10.7ms	11.6ms						1	0	
	21.4ms	23.3ms						1	1	
Advanced Switch time for 13-Band EQ(High) [5:4]	2.8ms	3.0ms			0	0				
	5.4ms	5.9ms			0	1				
	10.7ms	11.6ms			1	0				
	21.4ms	23.3ms			1	1				
Advanced Switch time for 3-Band Tone/HPF(Coef)/IIR A/IIR B [7:6]	5.4ms	5.9ms	0	0						
	10.7ms	11.6ms	0	1						
	21.4ms	23.3ms	1	0						
	42.8ms	46.6ms	1	1						

13-Band EQ(Low): Band1-Band5, 13-Band EQ(Middle): Band6-Band10, 13-Band EQ(High): Band11-Band13

Refer to "Advanced Switch" about Advanced Switch.

Select Address 0008(hex)

Function Name	Setting		MSB Initial Setup8 LSB							
	f _s =48kHz	f _s =44.1kHz	D7	D6	D5	D4	D3	D2	D1	D0
Advanced Switch time for Time Alignment [5:4]	2.8ms	3.0ms	1	1	0	0	0	0	1	1
	5.4ms	5.9ms			0	1				
	10.7ms	11.6ms			1	0				
	21.4ms	23.3ms			1	1				

Refer to "Advanced Switch" about Advanced Switch.

Command Specification - Continued

Select Address 0010(hex)

Function Name	Setting	Digital Format1																												
		MSB D7	D6	D5	D4	D3	D2	D1	LSB D0																					
BCK/LRCK direction(DINA)[0]	Output	0	0	0	0	0	0	0	0																					
	Input								1																					
BCK/LRCK direction(DINB)[1]	Output								0	0	0	0	0	0	0	0														
	Input															1														
BCK/LRCK direction(DINC)[2]	Output															0	0	0	0	0	0	0	0							
	Input																						1							
BCK/LRCK direction(DIND)[3]	Output																						0	0	0	0	0	0	0	0
	Input																													1
BEEP I/F[5]	Disable	0	0	0	0	0	0	0																						0
	Enable																													1

The input/output direction setting of BCK/LRCK when it is used as selector.
Refer to "Digital IO Selector".

Select Address 0011(hex)

Function Name	Setting	Digital Format2															
		MSB D7	D6	D5	D4	D3	D2	D1	LSB D0								
Digital IO Bit Width(Input1) [1:0]	24bits	0	0	0	0	0	0	0	0	0							
	20bits								0	1							
	16bits								1	0							
	24bits								1	1							
Digital IO Format(Input1) [3:2]	I ² S								0	0	0	0	0	0	0	0	0
	Left-Justified															0	1
	Right-Justified															1	0
	S/PDIF															1	1

Select Address 0012(hex)

Function Name	Setting	Digital Format3															
		MSB D7	D6	D5	D4	D3	D2	D1	LSB D0								
Digital IO Bit Width(Input3) [1:0]	24bits	0	0	0	0	0	0	0	0	0							
	20bits								0	1							
	16bits								1	0							
	24bits								1	1							
Digital IO Format(Input3) [3:2]	I ² S								0	0	0	0	0	0	0	0	0
	Left-Justified															0	1
	Right-Justified															1	0
	S/PDIF															1	1

Select Address 0013(hex)

Function Name	Setting	Digital Format4															
		MSB D7	D6	D5	D4	D3	D2	D1	LSB D0								
Digital IO Bit Width(Output1) [1:0]	24bits	0	0	0	0	0	0	0	0	0							
	20bits								0	1							
	16bits								1	0							
	24bits								1	1							
Digital IO Format(Output1) [3:2]	I ² S								0	0	0	0	0	0	0	0	0
	Left-Justified															0	1
	Right-Justified															1	0
	S/PDIF															1	1

When "Digital IO Format"=S/PDIF, output ch is only Front-2ch.

Command Specification - Continued

Select Address 0014(hex)

Function Name	Setting	Digital Format5														
		MSB D7	D6	D5	D4	D3	D2	D1	LSB D0							
S/PDIF Emphasis (Output1)[0]	No Emphasis	0	0	0	0	0	0	0	0							
	Pre Emphasis								1							
S/PDIF Copyright (Output1)[1]	Copyright								0	0	0	0	0	0	0	0
	No Copyright															1
S/PDIF Clock Accuracy (Output1) [5:4]	Level II								0	0	0	0	0	0	0	
	Level III										0	1				
	Level I										1	0				
	Error										1	1				

When "Digital IO Format"=S/PDIF, Channel Status Data is setup
The S/PDIF is supported in IEC60958-3: consumer applications.

Select Address 0015(hex)

Function Name	Setting	Digital Format6							
		MSB D7	D6	D5	D4	D3	D2	D1	LSB D0
S/PDIF Category (Output1)[7:0]	Data	00(hex) to FF(hex)(Initial=00(hex))							

When "Digital IO Format"=S/PDIF, Channel Status Data is setup.

Select Address 0016(hex)

Function Name	Setting	Digital Format7							
		MSB D7	D6	D5	D4	D3	D2	D1	LSB D0
Digital IO Bit Width(Output3) [1:0]	24bits	0	0	0	0	0	0	0	0
	20bits								0
	16bits								1
	24bits								1
Digital IO Format(Output3) [3:2]	I ² S	0	0	0	0	0	0	0	0
	Left-Justified								0
	Right-Justified								1
	S/PDIF								1

Select Address 0017(hex)

Function Name	Setting	Digital Format8														
		MSB D7	D6	D5	D4	D3	D2	D1	LSB D0							
S/PDIF Emphasis (Output3)[0]	No Emphasis	0	0	0	0	0	0	0	0							
	Pre Emphasis								1							
S/PDIF Copyright (Output3)[1]	Copyright								0	0	0	0	0	0	0	0
	No Copyright															1
S/PDIF Clock Accuracy (Output3) [5:4]	Level II								0	0	0	0	0	0	0	
	Level III										0	1				
	Level I										1	0				
	Error										1	1				

When "Digital IO Format"=S/PDIF, Channel Status Data is setup.

Select Address 0018(hex)

Function Name	Setting	Digital Format9							
		MSB D7	D6	D5	D4	D3	D2	D1	LSB D0
S/PDIF Category (Output3)[7:0]	Data	00(hex) to FF(hex)(Initial=00(hex))							

When "Digital IO Format"=S/PDIF, Channel Status Data is setup.

Command Specification - Continued

Select Address 0019(hex)

Function Name	Setting	Digital Format10							
		MSB D7	D6	D5	D4	D3	D2	D1	LSB D0
Digital IO Bit Width(ExtIO) [1:0]	24bits							0	0
	20bits							0	1
	16bits							1	0
	24bits							1	1
Digital IO Format(ExtIO) [3:2]	I ² S			0	0	0	0		
	Left-Justified					0	1		
	Right-Justified					1	0		
	I ² S					1	1		
Sub Input Selector(ExtIO)[6]	Sub		0						
	Front copy		1						
Rear Input Selector(ExtIO)[7]	Rear	0							
	Front copy	1							

Refer to "Digital ExtIO (Digital Input2/Digital Output2)" about ExtIO.

Select Address 001A(hex)

Function Name	Setting	Sync Detection1(Input1)							
		MSB D7	D6	D5	D4	D3	D2	D1	LSB D0
Audio frame counts for sync detection (Input1) [3:0]	0(hex) to F(hex)					0	0	0	0
						0	0	0	1
		:	:	:	:	:	:	:	:
		1	1	1	1	1	1	1	0
		1	1	1	1	1	1	1	1
MUTE during Sync Error[7]	Disable	0							
	Enable	1							

Refer to "Sync Error Detection" about sync detection.

Select Address 001B(hex)

Function Name	Setting	Sync Detection2(Input3)							
		MSB D7	D6	D5	D4	D3	D2	D1	LSB D0
Audio frame counts for sync detection (Input3) [3:0]	0(hex) to F(hex)					0	0	0	0
						0	0	0	1
		:	:	:	:	:	:	:	:
		1	1	1	1	1	1	1	0
		1	1	1	1	1	1	1	1
MUTE during Sync Error[7]	Disable	0							
	Enable	1							

Refer to "Sync Error Detection" about sync detection.

Select Address 001C(hex)

Function Name	Setting	Sync Detection3(ExtIO)							
		MSB D7	D6	D5	D4	D3	D2	D1	LSB D0
Audio frame counts for sync detection (ExtIO) [3:0]	0(hex) to F(hex)					0	0	0	0
						0	0	0	1
		:	:	:	:	:	:	:	:
		1	1	1	1	1	1	1	0
		1	1	1	1	1	1	1	1
MUTE during Sync Error[7]	Disable	0							
	Enable	1							

Refer to "Sync Error Detection" about sync detection.

Command Specification - Continued

Select Address 001D(hex)

Function Name	Setting	Test A							
		MSB							LSB
		D7	D6	D5	D4	D3	D2	D1	D0
Test A[7:0]	-	0	0	0	0	0	0	0	0

Select Address 001E(hex)

Function Name	Setting	Test B							
		MSB							LSB
		D7	D6	D5	D4	D3	D2	D1	D0
Test B[7:0]	-	1	1	0	0	0	0	0	0

Select Address 001F(hex)

Function Name	Setting	Test C							
		MSB							LSB
		D7	D6	D5	D4	D3	D2	D1	D0
Test C[7:0]	-	0	0	0	0	0	0	0	0

Select Address 0020(hex)

Function Name	Setting	Test D							
		MSB							LSB
		D7	D6	D5	D4	D3	D2	D1	D0
Test D[7:0]	-	1	1	0	0	0	0	0	0

Select Address 0021(hex)

Function Name	Setting	Test E							
		MSB							LSB
		D7	D6	D5	D4	D3	D2	D1	D0
Test E[7:0]	-	0	0	1	1	0	1	0	0

Select Address 0022(hex)

Function Name	Setting	Test F							
		MSB							LSB
		D7	D6	D5	D4	D3	D2	D1	D0
Test F[7:0]	-	0	0	0	0	0	1	0	1

Do not send the data that are not designated in table of Test A to Test F.

Select Address 0101(hex)

Function Name	Setting	Input Gain							
		MSB							LSB
		D7	D6	D5	D4	D3	D2	D1	D0
Input Gain [5:0]	0dB	0	0	0	0	0	0	0	0
	1dB			0	0	0	0	0	1
	2dB			0	0	0	0	1	0
	:			:	:	:	:	:	
	20dB			0	1	0	1	0	0
	21dB			0	1	0	1	0	1
	22dB			0	1	0	1	1	0
	:			:	:	:	:	:	
	35dB			1	0	0	0	1	1
	36dB			1	0	0	1	0	0
	Prohibited				1	0	0	1	0
		1	0	0	1	1	0		
		1	1	1	1	1	0		
		1	1	1	1	1	1		

Send data(hex)=Input Gain

Example. Input Gain=12dB, Send data(hex)=12→0C(hex)

Command Specification - Continued

Select Address 0102(hex)

Function Name	Setting	Fader Input Selector							
		MSB D7	D6	D5	D4	D3	D2	D1	LSB D0
Rear Selector [1:0]	RL/RR	0	0	0	0	0	0	0	0
	SL/SR							0	1
	SL/SL							1	0
	Prohibited							1	1
Sub Selector [5:4]	SL/SR	0	0	0	0	0	0		
	RL/RR			0	1				
	SL/SL			1	0				
	Prohibited			1	1				

When 0109(hex) Digital Mixing Selector is set up, set it except SL/SR(Rear Selector 0102(hex)[1:0]=00 or 10, Sub Selector 0102(hex)[5:4]=01 or 10) as Rear/Sub Selector.
Refer to ["Mixing"](#), ["Fader Input Selector"](#).

Select Address 0103(hex)

Function Name	Setting	Analog Input Selector										
		MSB D7	D6	D5	D4	D3	D2	D1	LSB D0			
Analog Input Selector [2:0]	Single1					0	0	0	0			
	Single2						0	0	1			
	Single3						0	1	0			
	Single4						0	1	1			
	Single5						1	0	0			
	Diff A						1	0	1			
	Diff B						1	1	0			
	Diff C						1	1	1			
Analog Mixing Input Selector [6:4]	Single M1		0	0	0	0						
	Single M2									0	0	1
	Single M3									0	1	0
	Single M4									0	1	1
	Diff MA									1	0	0
	Diff MB									1	0	1
	Prohibited									1	1	0
Select Mode [7]	Normal Mode	0										
	Short Mode	1										

Short Mode is the command which reduces input impedance of all pins (Analog Input Selector and VREFL, VREFR).
The charge time of external coupling capacitors become short with this command. Use this command at power up/power down. Cancel the setup of Selector from Short Mode (Select Mode: Normal Mode), after power is supplied.
If Selector is not used, it is recommended to setup Selector to Single2/M4.
Refer to ["Analog Input Selector"](#), ["Analog Mixing Input"](#) about Analog (Mixing) Input Selector.

Select Address 0104(hex)

Function Name	Setting	Analog Mixing Selector1							
		MSB D7	D6	D5	D4	D3	D2	D1	LSB D0
Analog Mixing Source(RR) [1:0]	MixL							0	0
	MixR							0	1
	Stereo Mix							1	0
	Prohibited							1	1
Analog Mixing Source(RL) [3:2]	MixL					0	0		
	MixR					0	1		
	Stereo Mix					1	0		
	Prohibited					1	1		
Analog Mixing Source(FR) [5:4]	MixL			0	0				
	MixR			0	1				
	Stereo Mix			1	0				
	Prohibited			1	1				
Analog Mixing Source(FL) [7:6]	MixL	0	0						
	MixR	0	1						
	Stereo Mix	1	0						
	Prohibited	1	1						

Refer to ["Mixing"](#), ["Analog Mixing Input"](#) about Analog Mixing Source.

Command Specification - Continued

Select Address 0105(hex)

Function Name	Setting	Analog Mixing Selector2							
		MSB D7	D6	D5	D4	D3	D2	D1	LSB D0
Analog Mixing Source(SR) [1:0]	MixL							0	0
	MixR							0	1
	Stereo Mix							1	0
	Prohibited							1	1
Analog Mixing Source(SL) [3:2]	MixL		0	0	0	0	0		
	MixR						0	1	
	Stereo Mix						1	0	
	Prohibited						1	1	
Stereo Mix Gain [7]	0dB	0							
	+6dB	1							

Select Address 0106(hex)

Function Name	Setting	Analog Mixing Selector3							
		MSB D7	D6	D5	D4	D3	D2	D1	LSB D0
Analog Mixing(SR) [0]	OFF								0
	ON								1
Analog Mixing(SL) [1]	OFF							0	
	ON							1	
Analog Mixing(RR) [2]	OFF						0		
	ON						1		
Analog Mixing(RL) [3]	OFF					0			
	ON					1			
Analog Mixing(FR) [4]	OFF				0				
	ON				1				
Analog Mixing(FL) [5]	OFF			0					
	ON			1					

Refer to "Mixing" about Analog Mixing, Refer to "Mixing Advanced Switch" about Mixing Advanced Switch.
Do not send Mixing ON/OFF data(0106(hex)[5:0], 0109(hex)[5:0]) during same channel Fader Volume Advanced Switch operation. Pop noise may occur.

Select Address 0107(Lch), 0108(Rch)(hex)

Function Name	Setting	AVol(AMix)(Lch/Rch)								
		MSB D7	D6	D5	D4	D3	D2	D1	LSB D0	
AVol(AMix) [6:0]	-∞dB		0	0	0	0	0	0	0	
	Prohibited			0	0	0	0	0	0	1
				0	0	0	0	0	1	0
		:	:	:	:	:	:	:	:	:
				0	0	1	1	0	0	0
				0	0	1	1	0	0	1
		+6dB		0	0	1	1	0	1	0
		+5dB		0	0	1	1	0	1	1
		+4dB		0	0	1	1	1	0	0
		+3dB		0	0	1	1	1	0	1
		+2dB		0	0	1	1	1	1	0
	+1dB		0	0	1	1	1	1	1	
	0dB		0	1	0	0	0	0	0	
	-1dB		0	1	0	0	0	0	1	
	-2dB		0	1	0	0	0	1	0	
	-3dB		0	1	0	0	0	1	1	
	:	:	:	:	:	:	:	:	:	
	-62dB		1	0	1	1	1	1	0	
	-63dB		1	0	1	1	1	1	1	
	Prohibited			1	1	1	0	0	0	0
			1	1	1	0	0	0	1	
:		:	:	:	:	:	:	:		
			1	1	1	1	1	1	0	
		1	1	1	1	1	1	1		

Send data(hex)="32" - "AVol(AMix)"
Example. AVol(AMix)=-23dB, Send data(hex)=(32) - (-23)=55→37(hex)
Refer to "Mixing".

Command Specification - Continued

Select Address 0109(hex)

Function Name	Setting	Digital Mixing Selector							
		MSB D7	D6	D5	D4	D3	D2	D1	LSB D0
Digital Mixing(SR) [0]	OFF	1	1	1	1	1	1	1	0
	ON								1
Digital Mixing(SL) [1]	OFF								0
	ON								1
Digital Mixing(RR) [2]	OFF								0
	ON								1
Digital Mixing(RL) [3]	OFF								0
	ON								1
Digital Mixing(FR) [4]	OFF								0
	ON								1
Digital Mixing(FL) [5]	OFF								0
	ON								1
DAC Digital Mixing Mode[6]	OFF								0
	ON								1

When Digital Mixing is used, set DAC Digital Mixing Mode 0109(hex)[6] as ON simultaneously. Refer to "Mixing".
Do not send Mixing ON/OFF data(0106(hex)[5:0], 0109(hex)[5:0]) during same channel Fader Volume Advanced Switch operation. Pop noise may occur.

Select Address 010A(hex)

Function Name	Setting	AVol(DMix)								
		MSB D7	D6	D5	D4	D3	D2	D1	LSB D0	
AVol(DMix) [6:0]	-∞dB	1	0	0	0	0	0	0	0	
	Prohibited		0	0	0	0	0	0	0	1
			0	0	0	0	0	0	1	0
			:	:	:	:	:	:	:	:
			0	0	1	1	1	1	1	0
	0dB		0	1	0	0	0	0	0	0
	-1dB		0	1	0	0	0	0	0	1
	-2dB		0	1	0	0	0	0	1	0
	-3dB		0	1	0	0	0	0	1	1
	:		:	:	:	:	:	:	:	:
	-68dB		1	1	0	0	1	0	0	0
	-69dB		1	1	0	0	1	0	1	1
	Prohibited		1	1	0	0	1	1	0	0
			1	1	0	0	1	1	1	1
			:	:	:	:	:	:	:	:
			1	1	1	1	1	1	1	0
		1	1	1	1	1	1	1		

Send data(hex)="32" - "AVol(DMix)"
Example. AVol(DMix)=-23dB, Send data(hex)=(32) - (-23)=55→37(hex)
Refer to "Mixing".

Command Specification - Continued

Select Address 0200(hex)

Function Name	Setting	Digital IO Selector1						LSB	
		MSB D7	D6	D5	D4	D3	D2	D1	D0
Digital ExtIO IO Selector [1:0]	Disable							0	0
	C-1	0	0	0	0	0	0	0	1
	B-1							1	0
	C-2							1	1

Refer to "Digital IO Selector" about the usage of a selector and Setting.

Select Address 0201(hex)

Function Name	Setting	Digital IO Selector2						LSB		
		MSB D7	D6	D5	D4	D3	D2	D1	D0	
Digital Output1 IO Selector [2:0]	Disable							0	0	0
	A-1							0	0	1
	B-1							0	1	0
	C-1							0	1	1
	D-1							1	0	0
	B-2							1	0	1
	C-2							1	1	0
Digital Output3 IO Selector [6:4]	C-3							1	1	1
	Disable	0	0	0	0	0				
	A-1		0	0	1					
	B-1		0	1	0					
	C-1		0	1	1					
	D-1		1	0	0					
	Prohibited		1	0	1					
		1	1	0						
		1	1	1						

Refer to "Digital IO Selector" about the usage of a selector and Setting.

Select Address 0202(hex)

Function Name	Setting	Digital IO Selector3						LSB				
		MSB D7	D6	D5	D4	D3	D2	D1	D0			
Digital Input1 IO Selector [3:0]	Disable							0	0	0	0	
	A-1							0	0	0	1	
	B-1							0	0	1	0	
	B-2							0	0	1	1	
	B-3							0	1	0	0	
	B-4							0	1	0	1	
	C-1							0	1	1	0	
	C-2							0	1	1	1	
	D-1							1	0	0	0	
	Prohibited								1	0	0	1
									1	0	1	0
									1	0	1	1
									1	1	0	0
								1	1	0	1	
								1	1	1	0	
								1	1	1	1	
Digital Input3 IO Selector [7:4]	Disable	0	0	0	0							
	A-1	0	0	0	1							
	B-1	0	0	1	0							
	B-2	0	0	1	1							
	B-3	0	1	0	0							
	B-4	0	1	0	1							
	C-1	0	1	1	0							
	C-2	0	1	1	1							
	D-1	1	0	0	0							
	Prohibited		1	0	0	1						
			1	0	1	0						
		1	0	1	1							
		1	1	0	0							
		1	1	0	1							
		1	1	1	0							
		1	1	1	1							

Refer to "Digital IO Selector" about the usage of a selector and Setting.

Command Specification - Continued

Select Address 0203(hex)

Function Name	Setting	MSB							
		D7	D6	D5	DSP Selector1		D2	D1	LSB
						D3			D0
Time Alignment Mode[3]	2ch-input Mode (21.3ms/ch f _s =48kHz) (23.0ms/ch f _s =44.1kHz)					0			
	4ch-input Mode (10.6ms/ch f _s =48kHz) (11.5ms/ch f _s =44.1kHz)					1			
Time Alignment Input Selector[4]	Loudness				0				
	DC Cut HPF(Input2)				1		0	0	0
SpeAna Input Selector[5]	DSP Input			0					
	DC Cut HPF(Input2)			1					
Loudness Input Selector[6]	SpeAna Input		0						
	Noise Gen		1						
DSP Input Selector[7]	DC Cut HPF(ADC)	0							
	DC Cut HPF(Input1)	1							

Refer to "Signal Flow" about selector. Refer to "Time Alignment Mode" about Time Alignment Mode.

Select Address 0204(hex)

Function Name	Setting	MSB							
		D7	D6	D5	DSP Selector2		D2	D1	LSB
						D3			D0
Noise Gen [0]	OFF								0
	ON								1
Noise Selector [2]	Pink Noise	0	0	0	0	0	0	0	
	White Noise						0		

When setup Noise Gen=ON, each Noise(Noise Selector=Pink Noise or White Noise) is generating continuously.

Select Address 0205(hex)

Function Name	Setting	MSB							
		D7	D6	D5	DSP Selector3		D2	D1	LSB
						D3			D0
P ² Bass Input Selector(Rear) [5:4]	Time Alignment			0	0				
	DC Cut HPF(Input2)			0	1				
	Surround	0		1	0		1	0	1
	Prohibited			1	1				
P ² Bass Input Selector(Front)[6]	Time Alignment		0						
	DC Cut HPF(Input2)		1						

Refer to "Signal Flow" about selector.

Select Address 0206(hex)

Function Name	Setting	MSB							
		D7	D6	D5	DSP Selector4		D2	D1	LSB
						D3			D0
Digital Mixing Input Selector [0]	DC Cut HPF (Input3-L/R)								0
	DC Cut HPF (Input2-SL/-SR)								1
Digital Mixing Stereo Mix[1]	Monaural(L)							0	
	Stereo Mix(L+R)							1	
SR Volume Input Selector [5:4]	SL X'over			0	0				
	DC Cut HPF (Input2-SR)			0	1		0		
	DC Cut HPF (Input3-R)			1	0				
	Digital Mixing			1	1				
SL X'over Input Selector [7:6]	Time Alignment	0	0						
	DC Cut HPF (Input2-SL)	0	1						
	DC Cut HPF (Input3-L)	1	0						
	Prohibited	1	1						

Refer to "Signal Flow" about selector.

Command Specification - Continued

Select Address 0207(hex)

Function Name	Setting	MSB DSP Selector5 LSB								
		D7	D6	D5	D4	D3	D2	D1	D0	
Digital Output1 Front Selector [1:0]	FL/FR	0	0						0	0
	RL/RR								0	1
	SL/SR								1	0
	Prohibited								1	1
Digital Output1 Rear Selector [3:2]	RL/RR	0	0						0	0
	SL/SR								0	1
	SL/SL								1	0
	Prohibited								1	1
Digital Output1 Sub Selector [5:4]	SL/SR	0	0						0	0
	RL/RR								0	1
	Prohibited								1	0
	SL/SL								1	1

Refer to "Signal Flow" about selector.

Select Address 0208(hex)

Function Name	Setting	MSB DSP Selector6 LSB									
		D7	D6	D5	D4	D3	D2	D1	D0		
Digital Output2 Selector [1:0]	SpeAna Input	0	0						0	0	
	Loudness								0	1	
	Time Alignment								1	0	
	DSP Input								1	1	
Digital Output3 Selector [5:4]	SL/SR	0	0			0	0			0	0
	Prohibited									0	1
	DC Cut HPF(Input3)									1	0
	SL/SL									1	1

Refer to "Signal Flow" about selector.

Select Address 0400(FL), 0402(FR), 0404(RL), 0406(RR), 0408(S), 040A(RL2), 040C(RR2)(hex)

Function Name	Setting	MSB Time Alignment LSB							
		D7	D6	D5	D4	D3	D2	D1	D0
Time Alignment Time (FL/FR/RL/RR/S/RL2/RR2) [1:0]	Time Alignment Time[9:8]	0	0	0	0	0	0	[9:8] High-2bit Initial: 00	

Select Address 0401(FL), 0403(FR), 0405(RL), 0407(RR), 0409(S), 040B(RL2), 040D(RR2)(hex)

Function Name	Setting	MSB Time Alignment LSB							
		D7	D6	D5	D4	D3	D2	D1	D0
Time Alignment Time (FL/FR/RL/RR/S/RL2/RR2) [7:0]	Time Alignment Time[7:0]	[7:0]00(hex) to FF(hex)(10bit-Coefficient: Low-8bit) Initial: 00(hex)							

Send data(hex)="Time Alignment Time" x "48"

Example. Time Alignment Time=2.5ms, Send data(hex)=2.5 x 48=120→78(hex)

S is the Mixing system from the Time Alignment of FL and FR, and Time Alignment value can be setup independently from FL and FR.

- 21.3ms($f_s=48\text{kHz}$) or 23.0ms($f_s=44.1\text{kHz}$) is maximum in 2ch-input Mode. Setting data is: 3FF(hex).
- 10.6ms($f_s=48\text{kHz}$) or 11.5ms($f_s=44.1\text{kHz}$) is maximum in 4ch-input Mode. Setting data is: 1FF(hex). (Data from 200(hex) to 3FF(hex) is Prohibited.)

Time Alignment setting is reflected after writing in a coefficient Time Alignment Time[7:0].

Refer to "Time Alignment Mode".

Command Specification - Continued

Select Address 0500(hex)

Function Name	Setting	Spectrum Analyzer1							
		MSB D7	D6	D5	D4	D3	D2	D1	LSB D0
BPF Q [1:0]	7.5							0	0
	5.1							0	1
	3.6							1	0
	2.4							1	1
Spectrum Analyzer Input Selector [5:4]	LR MIX			0	0	0	1		
	Lch			0	1				
	Rch			1	0				
	Prohibited			1	1				
Spectrum Analyzer Type [7:6]	Averaging	0	0						
	Peak Hold	0	1						
	Level Meter	1	0						
	Signal Through	1	1						

When Spectrum Analyzer Type=Level Meter/Signal Through, a setup of D1-D0 is invalid, since BPF is bypassed.
 In addition, a setup of D5-D4 is invalid since Band1: LR MIX, Band2: Lch and Band3: Rch are fixed.
 Refer to [“Spectrum Analyzer”](#).

Select Address 0501(hex)

Function Name	Setting	Spectrum Analyzer2								
		MSB D7	D6	D5	D4	D3	D2	D1	LSB D0	
Spectrum Analyzer Gain [4:0]	0dB				0	0	0	0	0	
	2dB				0	0	0	0	1	
	4dB				0	0	0	1	0	
	:				:	:	:	:	:	
	32dB				1	0	0	0	0	
	34dB				1	0	0	0	1	
	36dB	0	0	0	1	0	0	1	0	
	Prohibited					1	0	0	1	1
						1	0	1	0	0
						:	:	:	:	:
					1	1	1	1	0	
				1	1	1	1	1		

Send data(hex)=“Spectrum Analyzer Gain”/2
 Example. Spectrum Analyzer Gain=24dB, Send data(hex)=24/2=12→0C(hex)
 Refer to [“Spectrum Analyzer”](#).

Select Address 0600(hex)

Function Name	Setting	EQ Mode/Scaler							
		MSB D7	D6	D5	D4	D3	D2	D1	LSB D0
PostScaler (Front/Rear) [2:0]	0dB					0	0	0	0
	12dB						0	0	1
	24dB						0	1	0
	36dB						0	1	1
	48dB						1	0	0
	60dB						1	0	1
	72dB						1	1	0
84dB					1	1	1		
PreScaler (Front/Rear) [6:4]	0dB		0	0	0	0			
	-12dB		0	0	1				
	-24dB		0	1	0				
	-36dB		0	1	1				
	-48dB		1	0	0				
	-60dB		1	0	1				
	-72dB		1	1	0				
-84dB		1	1	1					
EQ Mode [7]	13-Band EQ+Tone	0							
	16-Band EQ	1							

3-Band EQ become effective instead of 3-Band Tone (Bass(061D(hex), 062D(hex)), Middle(061E(hex), 062E(hex)),
 Treble(061F(hex), 062F(hex)))during EQ Mode=16-Band EQ.

Command Specification - Continued

13-Band + 3-Band EQ(Front) Select Address "Band" and "f₀"

Band	f ₀	Select Address	Band	f ₀	Select Address	Band	f ₀	Select Address	Band	f ₀	Select Address
1	50Hz	0610(hex)	5	315Hz	0614(hex)	9	2kHz	0618(hex)	13	12.5kHz	061C(hex)
2	80Hz	0611(hex)	6	500Hz	0615(hex)	10	3.15kHz	0619(hex)	A	20Hz	061D(hex)
3	125Hz	0612(hex)	7	800Hz	0616(hex)	11	5kHz	061A(hex)	B	31.5Hz	061E(hex)
4	200Hz	0613(hex)	8	1.25kHz	0617(hex)	12	8kHz	061B(hex)	C	20kHz	061F(hex)

Select Address 0610(hex) to 061C(hex)

Function Name	Setting	13-Band EQ(Front)							
		MSB D7	D6	D5	D4	D3	D2	D1	LSB D0
EQ Gain [3:0]	0dB					0	0	0	0
	2dB					0	0	0	1
	4dB					0	0	1	0
	6dB					0	0	1	1
	8dB					0	1	0	0
	10dB					0	1	0	1
	12dB					0	1	1	0
	14dB					0	1	1	1
	16dB					1	0	0	0
	18dB					1	0	0	1
	20dB					1	0	1	0
	22dB					1	0	1	1
	24dB					1	1	0	0
	Prohibited					1	1	1	0
					1	1	1	1	
EQ Gain Boost/Cut [4]	Boost				0				
	Cut				1				
EQ Q [5]	4.7			0					
	2.2			1					
Ch Selector [6]	Front Only		0						
	Front/Rear		1						
Direct Coef Set [7]	Table	0							
	Coef	1							

When Ch Selector=Front/Rear, the setup of Rear(0620(hex) to 062C(hex)) is as same setup as setup of Front. When Front/Rear common setup is canceled, make Rear and Front have the same setup in advance. When the setup of the Rear and Front are different, pop noise may occur. (When Front/Rear common setup is canceled, Rear setup is automatically updated to the original setup, but switching of Rear setup is Done momentarily.)

When Direct Coef Set=Coef, It becomes a coefficient direct setup. Direct Coef Set can be set only by Front, and serves as common setup for both Front/Rear. When the setup of Direct Coef Set is changed from Coef to Table, set Ch Selector to Front/Rear, in advance. When the setup of Ch Selector is Front only, because switching of Rear EQ setup Coef to Table is Done momentarily, pop noise may occur.

Command Specification - Continued

Select Address 061D(hex)

[Tone Bass: Front] EQ Mode(0600(hex)[7])=13-Band EQ+Tone

Function Name	Setting	MSB			3-Band Tone Bass(Front)				LSB	
		D7	D6	D5	D4	D3	D2	D1	D0	
Bass Gain [2:0]	0dB						0	0	0	
	2dB						0	0	1	
	4dB						0	1	0	
	6dB						0	1	1	
	8dB						1	0	0	
	10dB						1	0	1	
	12dB						1	1	0	
	Prohibited						1	1	1	
Bass Gain Boost/Cut[3]	Boost					0				
	Cut					1				
Bass f _c [5:4]	40Hz			0	0					
	63Hz			0	1					
	100Hz			1	0					
	160Hz			1	1					
Ch Selector [6]	Front Only		0							
	Front/Rear		1							
Direct Coef Set [7]	Table	0								
	Coef	1								

It becomes a coefficient direct setup when Direct Coef Set=Coef.

[Band A: Front(f₀: 20Hz)] EQ Mode(0600(hex)[7])=16-Band EQ

Function Name	Setting	MSB			3-Band EQ Band A(Front)				LSB	
		D7	D6	D5	D4	D3	D2	D1	D0	
EQ Gain [3:0]	0dB					0	0	0	0	
	2dB					0	0	0	1	
	4dB					0	0	1	0	
	6dB					0	0	1	1	
	8dB					0	1	0	0	
	10dB					0	1	0	1	
	12dB					0	1	1	0	
	14dB					0	1	1	1	
	16dB					1	0	0	0	
	18dB					1	0	0	1	
	20dB					1	0	1	0	
	22dB					1	0	1	1	
	24dB					1	1	0	0	
	Prohibited					1	1	0	1	
EQ Gain Boost/Cut [4]	Boost				0					
	Cut				1					
EQ Q [5]	4.7			0						
	2.2			1						
Ch Selector [6]	Front Only		0							
	Front/Rear		1							
Direct Coef Set [7]	Table	0								
	Coef	1								

When Ch Selector=Front/Rear, the setup of Rear(062D(hex)) is as same setup as setup of Front. When Front/Rear common setup is canceled, make Rear and Front have the same setup in advance. When the setup of the Rear and Front are different, pop noise may occur. (When Front/Rear common setup is canceled, Rear setup is automatically updated to the original setup, but switching of Rear setup is Done momentarily.)

When Direct Coef Set=Coef, It becomes a coefficient direct setup. Direct Coef Set can be set only by Front, and serves as common setup for both Front/Rear. When the setup of Direct Coef Set is changed from Coef to Table, set Ch Selector to Front/Rear, in advance. When the setup of Ch Selector is Front only, because switching of Rear EQ setup Coef to Table is Done momentarily, pop noise may occur.

Command Specification - Continued

Select Address 061E(hex)

[Tone Middle: Front] EQ Mode(0600(hex)[7])=13-Band EQ+Tone

Function Name	Setting	3-Band Tone Middle(Front)							
		MSB						LSB	
		D7	D6	D5	D4	D3	D2	D1	D0
Middle Gain [2:0]	0dB						0	0	0
	2dB						0	0	1
	4dB						0	1	0
	6dB						0	1	1
	8dB						1	0	0
	10dB						1	0	1
	12dB						1	1	0
	Prohibited						1	1	1
Middle Gain Boost/Cut[3]	Boost					0			
	Cut					1			
Middle f ₀ [5:4]	400Hz			0	0				
	630Hz			0	1				
	1kHz			1	0				
	1.6kHz			1	1				
Ch Selector [6]	Front Only		0						
	Front/Rear		1						
Direct Coef Set [7]	Table	0							
	Coef	1							

It becomes a coefficient direct setup when Direct Coef Set=Coef.

[Band B: Front(f₀: 31.5Hz)] EQ Mode(0600(hex)[7])=16-Band EQ

Function Name	Setting	3-Band EQ Band B(Front)							
		MSB						LSB	
		D7	D6	D5	D4	D3	D2	D1	D0
EQ Gain [3:0]	0dB					0	0	0	0
	2dB					0	0	0	1
	4dB					0	0	1	0
	6dB					0	0	1	1
	8dB					0	1	0	0
	10dB					0	1	0	1
	12dB					0	1	1	0
	14dB					0	1	1	1
	16dB					1	0	0	0
	18dB					1	0	0	1
	20dB					1	0	1	0
	22dB					1	0	1	1
	24dB					1	1	0	0
	Prohibited					1	1	0	1
EQ Gain Boost/Cut [4]	Boost				0				
	Cut				1				
EQ Q [5]	4.7			0					
	2.2			1					
Ch Selector [6]	Front Only		0						
	Front/Rear		1						
Direct Coef Set [7]	Table	0							
	Coef	1							

When Ch Selector=Front/Rear, the setup of Rear(062E(hex)) is as same setup as setup of Front. When Front/Rear common setup is canceled, make Rear and Front have the same setup in advance. When the setup of the Rear and Front are different, pop noise may occur. (When Front/Rear common setup is canceled, Rear setup is automatically updated to the original setup, but switching of Rear setup is Done momentarily.)

When Direct Coef Set=Coef, It becomes a coefficient direct setup. Direct Coef Set can be set only by Front, and serves as common setup for both Front/Rear. When the setup of Direct Coef Set is changed from Coef to Table, set Ch Selector to Front/Rear, in advance. When the setup of Ch Selector is Front only, because switching of Rear EQ setup Coef to Table is Done momentarily, pop noise may occur.

Command Specification - Continued

Select Address 061F(hex)

[Tone Treble: Front] EQ Mode(0600(hex)[7])=13-Band EQ+Tone

Function Name	Setting	3-Band Tone Treble(Front)							
		MSB D7	D6	D5	D4	D3	D2	D1	LSB D0
Treble Gain [2:0]	0dB						0	0	0
	2dB						0	0	1
	4dB						0	1	0
	6dB						0	1	1
	8dB						1	0	0
	10dB						1	0	1
	12dB						1	1	0
	Prohibited						1	1	1
Treble Gain Boost/Cut[3]	Boost					0			
	Cut					1			
Treble f _c [5:4]	2.5kHz			0	0				
	4kHz			0	1				
	6.3kHz			1	0				
	10kHz			1	1				
Ch Selector [6]	Front Only		0						
	Front/Rear		1						
Direct Coef Set [7]	Table	0							
	Coef	1							

Direct Coef Set=Coef It becomes a coefficient direct setup when Direct Coef Set=Coef.

[Band C: Front(f₀: 20kHz)] EQ Mode(0600(hex)[7])=16-Band EQ

Function Name	Setting	3-Band EQ Band C(Front)							
		MSB D7	D6	D5	D4	D3	D2	D1	LSB D0
EQ Gain [3:0]	0dB					0	0	0	0
	2dB					0	0	0	1
	4dB					0	0	1	0
	6dB					0	0	1	1
	8dB					0	1	0	0
	10dB					0	1	0	1
	12dB					0	1	1	0
	14dB					0	1	1	1
	16dB					1	0	0	0
	18dB					1	0	0	1
	20dB					1	0	1	0
	22dB					1	0	1	1
	24dB					1	1	0	0
	Prohibited					1	1	1	1
	EQ Gain Boost/Cut [4]	Boost				0			
Cut					1				
EQ Q [5]	4.7			0					
	2.2			1					
Ch Selector [6]	Front Only		0						
	Front/Rear		1						
Direct Coef Set [7]	Table	0							
	Coef	1							

When Ch Selector=Front/Rear, the setup of Rear(062F(hex)) is as same setup as setup of Front. When Front/Rear common setup is canceled, make Rear and Front have the same setup in advance. When the setup of the Rear and Front are different, pop noise may occur. (When Front/Rear common setup is canceled, Rear setup is automatically updated to the original setup, but switching of Rear setup is Done momentarily.)

When Direct Coef Set=Coef, It becomes a coefficient direct setup. Direct Coef Set can be set only by Front, and serves as common setup for both Front/Rear. When the setup of Direct Coef Set is changed from Coef to Table, set Ch Selector to Front/Rear, in advance. When the setup of Ch Selector is Front only, because switching of Rear EQ setup Coef to Table is Done momentarily, pop noise may occur.

Command Specification - Continued

13-Band + 3-Band EQ(Rear) Select Address "Band" and "f₀"

Band	f ₀	Select Address	Band	f ₀	Select Address	Band	f ₀	Select Address	Band	f ₀	Select Address
1	50Hz	0620(hex)	5	315Hz	0624(hex)	9	2kHz	0628(hex)	13	12.5kHz	062C(hex)
2	80Hz	0621(hex)	6	500Hz	0625(hex)	10	3.15kHz	0629(hex)	A	20Hz	062D(hex)
3	125Hz	0622(hex)	7	800Hz	0626(hex)	11	5kHz	062A(hex)	B	31.5Hz	062E(hex)
4	200Hz	0623(hex)	8	1.25kHz	0627(hex)	12	8kHz	062B(hex)	C	20kHz	062F(hex)

Select Address 0620(hex) to 062C(hex)

Function Name	Setting	13-Band EQ(Rear)							
		MSB						LSB	
		D7	D6	D5	D4	D3	D2	D1	D0
EQ Gain [3:0]	0dB	0	0			0	0	0	0
	2dB					0	0	0	1
	4dB					0	0	1	0
	6dB					0	0	1	1
	8dB					0	1	0	0
	10dB					0	1	0	1
	12dB					0	1	1	0
	14dB					0	1	1	1
	16dB					1	0	0	0
	18dB					1	0	0	1
	20dB					1	0	1	0
	22dB					1	0	1	1
	24dB					1	1	0	0
	Prohibited					1	1	0	1
EQ Gain Boost/Cut [4]	Boost				0				
	Cut				1				
EQ Q [5]	4.7			0					
	2.2			1					

When Ch Selector=Front/Rear by Front(0610(hex) to 061C(hex)), a setup of Rear becomes invalid.

When Front/Rear common setup is canceled, make Rear and Front have the same setup in advance. When the setup of the Rear and Front are different, pop noise may occur. (When Front/Rear common setup is canceled, Rear setup is automatically updated to the original setup, but switching of Rear setup is Done momentarily.)

When Direct Coef Set=Coef, It becomes a coefficient direct setup. Direct Coef Set can be set only by Front, and serves as common setup for both Front/Rear. When the setup of Direct Coef Set is changed from Coef to Table, set Ch Selector to Front/Rear, in advance. When the setup of Ch Selector is Front only, because switching of Rear EQ setup Coef to Table is Done momentarily, pop noise may occur.

Command Specification - Continued

Select Address 062D(hex)

[Tone Bass: Rear] EQ Mode(0600(hex)[7])=13-Band EQ+Tone

Function Name	Setting	MSB		3-Band Tone Bass(Rear)						LSB		
		D7	D6	D5	D4	D3	D2	D1	D0			
Bass Gain [2:0]	0dB	0	0							0	0	0
	2dB									0	0	1
	4dB									0	1	0
	6dB									0	1	1
	8dB									1	0	0
	10dB									1	0	1
	12dB									1	1	0
	Prohibited									1	1	1
Bass Gain Boost/Cut[3]	Boost					0						
	Cut					1						
Bass f _c [5:4]	40Hz			0	0							
	63Hz			0	1							
	100Hz			1	0							
	160Hz			1	1							

[Band A: Rear(f₀: 20Hz)] EQ Mode(0600(hex)[7])=16-Band EQ

Function Name	Setting	MSB		3-Band EQ Band A(Rear)						LSB					
		D7	D6	D5	D4	D3	D2	D1	D0						
EQ Gain [3:0]	0dB	0	0									0	0	0	0
	2dB											0	0	0	1
	4dB											0	0	1	0
	6dB											0	0	1	1
	8dB											0	1	0	0
	10dB											0	1	0	1
	12dB											0	1	1	0
	14dB											0	1	1	1
	16dB											1	0	0	0
	18dB											1	0	0	1
	20dB											1	0	1	0
	22dB											1	0	1	1
	24dB											1	1	0	0
	Prohibited											1	1	1	1
EQ Gain Boost/Cut [4]	Boost				0										
	Cut				1										
EQ Q [5]	4.7			0											
	2.2			1											

When Ch Selector=Front/Rear by Front(061D(hex)), a setup of Rear becomes invalid.
 When Front/Rear common setup is canceled, make Rear and Front have the same setup in advance. When the setup of the Rear and Front are different, pop noise may occur. (When Front/Rear common setup is canceled, Rear setup is automatically updated to the original setup, but switching of Rear setup is Done momentarily.)
 When Direct Coef Set=Coef, It becomes a coefficient direct setup. Direct Coef Set can be set only by Front, and serves as common setup for both Front/Rear. When the setup of Direct Coef Set is changed from Coef to Table, set Ch Selector to Front/Rear, in advance. When the setup of Ch Selector is Front only, because switching of Rear EQ setup Coef to Table is Done momentarily, pop noise may occur.

Command Specification - Continued

Select Address 062E(hex)

[Tone Middle: Rear] EQ Mode(0600(hex)[7])=13-Band EQ+Tone

Function Name	Setting	MSB		3-Band Tone Middle(Rear)					LSB	
		D7	D6	D5	D4	D3	D2	D1	D0	
Middle Gain [2:0]	0dB	0	0				0	0	0	
	2dB						0	0	1	
	4dB						0	1	0	
	6dB						0	1	1	
	8dB						1	0	0	
	10dB						1	0	1	
	12dB						1	1	0	
	Prohibited						1	1	1	
Middle Gain Boost/Cut[3]	Boost				0					
	Cut				1					
Middle f ₀ [5:4]	400Hz			0	0					
	630Hz			0	1					
	1kHz			1	0					
	1.6kHz			1	1					

[Band B: Rear (f₀: 31.5Hz)] EQ Mode(0600(hex)[7])=16-Band EQ

Function Name	Setting	MSB		3-Band EQ Band B(Rear)					LSB	
		D7	D6	D5	D4	D3	D2	D1	D0	
EQ Gain [3:0]	0dB	0	0				0	0	0	0
	2dB						0	0	0	1
	4dB						0	0	1	0
	6dB						0	0	1	1
	8dB						0	1	0	0
	10dB						0	1	0	1
	12dB						0	1	1	0
	14dB						0	1	1	1
	16dB						1	0	0	0
	18dB						1	0	0	1
	20dB						1	0	1	0
	22dB						1	0	1	1
	24dB						1	1	0	0
	Prohibited						1	1	1	1
EQ Gain Boost/Cut [4]	Boost				0					
	Cut				1					
EQ Q [5]	4.7			0						
	2.2			1						

When Ch Selector=Front/Rear by Front(061E(hex)), a setup of Rear becomes invalid.
 When Front/Rear common setup is canceled, make Rear and Front have the same setup in advance. When the setup of the Rear and Front are different, pop noise may occur. (When Front/Rear common setup is canceled, Rear setup is automatically updated to the original setup, but switching of Rear setup is Done momentarily.)
 When Direct Coef Set=Coef, It becomes a coefficient direct setup. Direct Coef Set can be set only by Front, and serves as common setup for both Front/Rear. When the setup of Direct Coef Set is changed from Coef to Table, set Ch Selector to Front/Rear, in advance. When the setup of Ch Selector is Front only, because switching of Rear EQ setup Coef to Table is Done momentarily, pop noise may occur.

Command Specification - Continued

Select Address 062F(hex)

[Tone Treble: Rear] EQ Mode(0600(hex)[7])=13-Band EQ+Tone

Function Name	Setting	MSB		3-Band Tone Treble(Rear)					LSB				
		D7	D6	D5	D4	D3	D2	D1	D0				
Treble Gain [2:0]	0dB	0	0							0	0	0	
	2dB									0	0	1	
	4dB									0	1	0	
	6dB									0	1	1	
	8dB									1	0	0	
	10dB									1	0	1	
	12dB									1	1	0	
	Prohibited									1	1	1	
Treble Gain Boost/Cut[3]	Boost									0			
	Cut									1			
Treble f _c [5:4]	2.5kHz											0	0
	4kHz											0	1
	6.3kHz											1	0
	10kHz											1	1

[Band C: Rear(f₀: 20kHz)] EQ Mode(0600(hex)[7])=16-Band EQ

Function Name	Setting	MSB		3-Band EQ Band C(Rear)					LSB						
		D7	D6	D5	D4	D3	D2	D1	D0						
EQ Gain [3:0]	0dB	0	0									0	0	0	0
	2dB											0	0	0	1
	4dB											0	0	1	0
	6dB											0	0	1	1
	8dB											0	1	0	0
	10dB											0	1	0	1
	12dB											0	1	1	0
	14dB											0	1	1	1
	16dB											1	0	0	0
	18dB											1	0	0	1
	20dB											1	0	1	0
	22dB											1	0	1	1
	24dB											1	1	0	0
	Prohibited											1	1	0	1
	EQ Gain Boost/Cut [4]											Boost			
Cut		1													
EQ Q [5]	4.7											0			
	2.2											1			

When Ch Selector=Front/Rear by Front(061F(hex)), a setup of Rear becomes invalid.
 When Front/Rear common setup is canceled, make Rear and Front have the same setup in advance. When the setup of the Rear and Front are different, pop noise may occur. (When Front/Rear common setup is canceled, Rear setup is automatically updated to the original setup, but switching of Rear setup is Done momentarily.)
 When Direct Coef Set=Coef, It becomes a coefficient direct setup. Direct Coef Set can be set only by Front, and serves as common setup for both Front/Rear. When the setup of Direct Coef Set is changed from Coef to Table, set Ch Selector to Front/Rear, in advance. When the setup of Ch Selector is Front only, because switching of Rear EQ setup Coef to Table is Done momentarily, pop noise may occur.

Command Specification - Continued

Select Address 0700(hex)

Function Name	Setting	DC Cut HPF/De-emphasis							
		MSB D7	D6	D5	D4	D3	D2	D1	LSB D0
DC Cut HPF (Input1)[0]	ON								0
	OFF								1
DC Cut HPF (Input2)[1]	ON							0	
	OFF							1	
DC Cut HPF (Input3)[2]	ON		0	0	0		0		
	OFF						1		
DC Cut HPF (ADC)[3]	ON					0			
	OFF					1			
De-emphasis Front/Rear(DAC)[7]	OFF	0							
	ON	1							

Select Address 0701(hex)

Function Name	Setting	Loudness Filter							
		MSB D7	D6	D5	D4	D3	D2	D1	LSB D0
Loudness LPF fc [2:0]	30Hz						0	0	0
	40Hz						0	0	1
	50Hz						0	1	0
	63Hz						0	1	1
	80Hz						1	0	0
	100Hz						1	0	1
	125Hz						1	1	0
	Prohibited						1	1	1
Loudness HPF fc [6:4]	3kHz		0	0	0	0			
	4kHz		0	0	1				
	5kHz		0	1	0				
	6.3kHz		0	1	1				
	8kHz		1	0	0				
	10kHz		1	0	1				
	12.5kHz		1	1	0				
	Prohibited		1	1	1				
Direct Coef Set [7]	Table	0							
	Coef	1							

When Direct Coef Set=Coef, it becomes a coefficient direct setup.

Select Address 0702(hex)

Function Name	Setting	Loudness Gain							
		MSB D7	D6	D5	D4	D3	D2	D1	LSB D0
Loudness Gain [3:0]	0dB					0	0	0	0
	-1dB					0	0	0	1
	-2dB					0	0	1	0
	-3dB					0	0	1	1
	-4dB					0	1	0	0
	-5dB					0	1	0	1
	-6dB					0	1	1	0
	-7dB					0	1	1	1
	-8dB					1	0	0	0
	-9dB					1	0	0	1
	-10dB		1	0		1	0	1	0
	-11dB					1	0	1	1
	-12dB					1	1	0	0
	-13dB					1	1	0	1
	-14dB					1	1	1	0
-15dB					1	1	1	1	
Loudness HiBoost [5:4]	0			0	0				
	0.2			0	1				
	0.55			1	0				
	1			1	1				

Loudness Gain means "f=1kHz Gain" in a setup of LPF fc=100Hz and HPF fc=10kHz.

Command Specification - Continued

Select Address 0703(hex)

Function Name	Setting	MSB			Front HPF				LSB	
		D7	D6	D5	D4	D3	D2	D1	D0	
Front HPF f_c [3:0]	Through	0			0	0	0	0	0	
	25Hz					0	0	0	1	
	31.5Hz					0	0	1	0	
	40Hz					0	0	1	1	
	50Hz					0	1	0	0	
	63Hz					0	1	0	1	
	80Hz					0	1	1	0	
	100Hz					0	1	1	1	
	125Hz					1	0	0	0	
	160Hz					1	0	0	1	
	200Hz					1	0	1	0	
	250Hz					1	0	1	1	
	Prohibited						1	1	0	0
							1	1	0	1
		1	1	1	0					
		1	1	1	1					
Front HPF Order [5]	2 nd order			0						
	4 th order			1						
Front HPF Phase [6]	0°		0							
	180°		1							
Direct Coef Set [7]	Table	0								
	Coef	1								

Direct Coef Set can be setup only by Front and serves as a Front/Rear common setup.
Moreover, it becomes a coefficient direct setup when Direct Coef Set=Coef.

Select Address 0704(hex)

Function Name	Setting	MSB			Rear HPF				LSB	
		D7	D6	D5	D4	D3	D2	D1	D0	
Rear HPF f_c [3:0]	Through	0			0	0	0	0	0	
	25Hz					0	0	0	1	
	31.5Hz					0	0	1	0	
	40Hz					0	0	1	1	
	50Hz					0	1	0	0	
	63Hz					0	1	0	1	
	80Hz					0	1	1	0	
	100Hz					0	1	1	1	
	125Hz					1	0	0	0	
	160Hz					1	0	0	1	
	200Hz					1	0	1	0	
	250Hz					1	0	1	1	
	Prohibited						1	1	0	0
							1	1	0	1
		1	1	1	0					
		1	1	1	1					
Rear HPF Order [5]	2 nd order			0						
	4 th order			1						
Rear HPF Phase [6]	0°		0							
	180°		1							

Command Specification - Continued

Select Address 0705(Front), 0706(Rear)(hex)

Function Name	Setting	MSB		P ² Bass(Front/Rear)						LSB	
		D7	D6	D5	D4	D3	D2	D1	D0		
P ² Bass Gain [3:0]	0dB	1				0	0	0	0		
	1dB					0	0	0	1		
	2dB					0	0	1	0		
	3dB					0	0	1	1		
	4dB					0	1	0	0		
	5dB					0	1	0	1		
	6dB					0	1	1	0		
	7dB					0	1	1	1		
	8dB					1	0	0	0		
	9dB					1	0	0	1		
	10dB					1	0	1	0		
	11dB					1	0	1	1		
	12dB					1	1	0	0		
	Prohibited					1	1	1	0	1	
P ² Bass f _c [6:4]	Through		0	0	0						
	54Hz	0	0	1							
	68Hz	0	1	0							
	86Hz	0	1	1							
	108Hz	1	0	0							
	134Hz	1	0	1							
	172Hz	1	1	0							
	214Hz	1	1	1							

Command Specification - Continued

Select Address 0707(hex)

Function Name	Setting	MSB			Sub LPF				LSB
		D7	D6	D5	D4	D3	D2	D1	D0
Sub LPF f_c [3:0]	Through			0		0	0	0	0
	25Hz				0	0	0	1	
	31.5Hz				0	0	1	0	
	40Hz				0	0	1	1	
	50Hz				0	1	0	0	
	63Hz				0	1	0	1	
	80Hz				0	1	1	0	
	100Hz				0	1	1	1	
	125Hz				1	0	0	0	
	160Hz				1	0	0	1	
	200Hz				1	0	1	0	
	250Hz				1	0	1	1	
	Prohibited				1	1	0	0	
			1	1	0	1			
			1	1	1	0			
			1	1	1	1			
Sub LPF Order [4]	2 nd order				0				
	4 th order				1				
Sub LPF Phase [6]	0°		0						
	180°		1						
Direct Coef Set [7]	Table	0							
	Coef	1							

It becomes a coefficient direct setup when Direct Coef Set=Coef.

Select Address 0708(hex)

Function Name	Setting	MSB			Sub HPF				LSB
		D7	D6	D5	D4	D3	D2	D1	D0
Sub HPF f_c [3:0]	Through			0		0	0	0	0
	20Hz				0	0	0	1	
	25Hz				0	0	1	0	
	31.5Hz				0	0	1	1	
	40Hz				0	1	0	0	
	50Hz				0	1	0	1	
	63Hz				0	1	1	0	
	80Hz				0	1	1	1	
	100Hz		0		0	0	1	0	0
	125Hz		0		0	0	1	0	1
	160Hz		0		0	0	1	0	0
	200Hz		0		0	0	1	0	1
	Prohibited		1		1	0	0		
		1	1	0	1				
		1	1	1	0				
		1	1	1	1				
Direct Coef Set [7]	Table	0							
	Coef	1							

It becomes a coefficient direct setup when Direct Coef Set=Coef.

Command Specification - Continued

Select Address 0709(hex)

Function Name	Setting	MSB		IIR						LSB
		D7	D6	D5	D4	D3	D2	D1	D0	
Direct Coef Set (Sub IIR)[6]	Through	0	0	0	0	0	0	0	0	
	Coef		1							
Direct Coef Set (IIR A/IIR B)[7]	Through	0	0	0	0	0	0	0	0	
	Coef	1								

It becomes a coefficient direct setup when Direct Coef Set=Coef.

Select Address 0800(hex)

Function Name	Setting	MSB		BEEP1						LSB
		D7	D6	D5	D4	D3	D2	D1	D0	
BEEP Level [7:0]	-∞dBFS	0	0	0	0	0	0	0	0	
	Prohibited		0	0	0	0	0	0	0	1
			0	0	0	0	0	0	1	0
			:	:	:	:	:	:	:	:
			0	0	1	1	1	1	1	0
			0	0	1	1	1	1	1	1
	0dBFS	0	1	0	0	0	0	0	0	0
	-0.5dBFS	0	1	0	0	0	0	0	1	
	-1.0dBFS	0	1	0	0	0	0	1	0	
	-1.5dBFS	0	1	0	0	0	0	1	1	
	:	:	:	:	:	:	:	:	:	
	-78.5dBFS	1	1	0	1	1	1	1	0	1
	-79.0dBFS	1	1	0	1	1	1	1	1	0
	Prohibited		1	1	0	1	1	1	1	1
			1	1	1	0	0	0	0	0
		:	:	:	:	:	:	:	:	
		1	1	1	1	1	1	1	0	
		1	1	1	1	1	1	1	1	

Setting data(hex)="64" - "BEEP Level" x 2

Example. BEEP Level=-23.5dBFS, Send data(hex)=(64) - (-23.5 x 2)=111(dec)→6F(hex)

Select Address 0801(hex)

Function Name	Setting	MSB		BEEP2						LSB
		D7	D6	D5	D4	D3	D2	D1	D0	
BEEP Frequency [2:0]	50Hz	0	0	0	0	0	0	0	0	
	500Hz						0	0	1	
	1kHz						0	1	0	
	2kHz						0	1	1	
	3kHz						1	0	0	
	Prohibited							1	0	1
								1	1	0
BEEP Type [3]	Sine wave	0	0	0	0	0	0	0	0	
	Rectangular wave									1
BEEP Repeat [6:4]	1	0	0	0	0	0	0	0	0	
	2			0	0	1				
	3			0	1	0				
	4			0	1	1				
	5			1	0	0				
	6			1	0	1				
	7			1	1	0				
	8			1	1	1				
BEEP Mode [7]	Auto	0	0	0	0	0	0	0	0	
	Manual	1								

When BEEP Mode=Manual, BEEP ON/OFF is performed by BEEP Trigger.

The signal of frequency setup by BEEP is continuously being outputted between Trigger=ON.

Refer to "BEEP".

Command Specification - Continued

Select Address 0802(hex)

Function Name	Setting	BEEP3							
		MSB D7	D6	D5	D4	D3	D2	D1	LSB D0
BEEP ON time [3:0]	32ms					0	0	0	0
	50ms					0	0	0	1
	100ms					0	0	1	0
	200ms					0	0	1	1
	250ms					0	1	0	0
	500ms					0	1	0	1
	600ms					0	1	1	0
	750ms					0	1	1	1
	1000ms					1	0	0	0
	3000ms					1	0	0	1
	Prohibited					1	0	1	0
						:	:	:	:
						1	1	1	1
BEEP OFF time [7:4]	32ms	0	0	0	0				
	50ms	0	0	0	1				
	100ms	0	0	1	0				
	200ms	0	0	1	1				
	250ms	0	1	0	0				
	500ms	0	1	0	1				
	600ms	0	1	1	0				
	750ms	0	1	1	1				
	1000ms	1	0	0	0				
	3000ms	1	0	0	1				
	Prohibited	1	0	1	0				
			:	:	:	:			
			1	1	1	0			
	0ms	1	1	1	1				

Refer to "BEEP".

Select Address 0803(hex)

Function Name	Setting	BEEP4							
		MSB D7	D6	D5	D4	D3	D2	D1	LSB D0
BEEP Trigger [0]	Normal/OFF								0
	Start/ON								1
BEEP Fade-OUT [2]	OFF						0		
	1ms						1		
BEEP Fade-IN [3]	OFF					0			
	1ms					1			
Direct Coef Set(fc) [4]	Table	0			0			0	
	Coef				1				
Direct Coef Set (ON time)[5]	Table			0					
	Coef			1					
Direct Coef Set (OFF time)[6]	Table		0						
	Coef		1						

When BEEP Trigger=start is received while BEEP Mode=Auto, according to the setup of BEEP1(0800(hex))/BEEP2 (0801(hex)), the repetition of ON/OFF of BEEP is performed automatically. BEEP is outputted every time BEEP Trigger =start is received. It doesn't need to return to BEEP Trigger=Normal to make BEEP out again.

A rising edge of the BEEP pin(Pin 49) can also make BEEP ON when BEEP I/F(0010(hex)[5])=Enable.

When BEEP Mode=Manual, ON/OFF of BEEP is performed by BEEP Trigger.

The signal of frequency setup in Trigger=ON is continuously being outputted. Moreover, when BEEP I/F(0010(hex)[5]) =Enable, BEEP Trigger setup becomes invalid and changing the BEEP ON/OFF is done by the BEEP pin(Pin 49).

Refer to "BEEP".

It becomes a coefficient direct setup when Direct Coef Set=Coef.

Command Specification - Continued

Select Address 0804(hex)

Function Name	Setting	Test1							
		MSB	Test1						LSB
		D7	D6	D5	D4	D3	D2	D1	D0
Test1[7:0]	-	0	0	0	0	0	0	0	0

Select Address 0805(hex)

Function Name	Setting	DVol(Output2)(L/R)								
		MSB	DVol(Output2)(L/R)						LSB	
		D7	D6	D5	D4	D3	D2	D1	D0	
DVol(Output2) (L/R) [7:0]	-∞dB	0	0	0	0	0	0	0	0	
	Prohibited	0	0	0	0	0	0	0	0	1
		0	0	0	0	0	0	0	1	0
		:	:	:	:	:	:	:	:	:
		0	0	1	1	1	1	1	1	0
		0	0	1	1	1	1	1	1	1
	0dB	0	1	0	0	0	0	0	0	0
	-0.5dB	0	1	0	0	0	0	0	0	1
	-1.0dB	0	1	0	0	0	0	0	1	0
	-1.5dB	0	1	0	0	0	0	0	1	1
	:	:	:	:	:	:	:	:	:	:
	-78.5dB	1	1	0	1	1	1	1	0	1
	-79.0dB	1	1	0	1	1	1	1	1	0
	Prohibited	1	1	0	1	1	1	1	1	1
		1	1	1	0	0	0	0	0	0
		:	:	:	:	:	:	:	:	:
1		1	1	1	1	1	1	1	0	
		1	1	1	1	1	1	1	1	

Setting data(hex)="64"-“DVol(Output2)” x 2

Example. DVol(Output2)=-23.5dB, Send data(hex)=64 - (-23.5 x 2)=111(dec)→6F(hex)

Select Address 0900(FL), 0901(FR), 0902(RL), 0903(RR), 0904(SL), 0905(SR)(hex)

Function Name	Setting	DVol(Att)(FL/FR/RL/RR/SL/SR)								
		MSB	DVol(Att)(FL/FR/RL/RR/SL/SR)						LSB	
		D7	D6	D5	D4	D3	D2	D1	D0	
DVol(Att) [7:0]	-∞dB	0	0	0	0	0	0	0	0	
	Prohibited	0	0	0	0	0	0	0	0	1
		:	:	:	:	:	:	:	:	:
		0	0	1	1	1	1	1	1	1
	0dB	0	1	0	0	0	0	0	0	0
	-0.5dB	0	1	0	0	0	0	0	0	1
	-1.0dB	0	1	0	0	0	0	0	1	0
	-1.5dB	0	1	0	0	0	0	0	1	1
	:	:	:	:	:	:	:	:	:	:
	-78.5dB	1	1	0	1	1	1	1	0	1
	-79.0dB	1	1	0	1	1	1	1	1	0
	-79.5dB	1	1	0	1	1	1	1	1	1
	-80.0dB	1	1	1	0	0	0	0	0	0
	-80.5dB	1	1	1	0	0	0	0	0	1
	:	:	:	:	:	:	:	:	:	:
	-94.5dB	1	1	1	1	1	1	1	0	1
-95.0dB	1	1	1	1	1	1	1	1	0	
-95.5dB	1	1	1	1	1	1	1	1	1	

Setting data(hex)="64"-“DVol(Att)” x 2

Example. DVol(Att)=-23.5dB, Send data(hex)=64 - (-23.5 x 2)=111(dec)→6F(hex)

Command Specification - Continued

Select Address 0906(FL), 0907(FR), 0908(RL), 0909(RR), 090A(SL), 090B(SR)(hex)

Function Name	Setting	DVol(Boost)(FL/FR/RL/RR/SL/SR)							
		MSB D7	D6	D5	D4	D3	D2	D1	LSB D0
DVol(Boost) [7:0]	-∞dB	0	0	0	0	0	0	0	0
	Prohibited	0	0	0	0	0	0	0	1
		:	:	:	:	:	:	:	:
		0	0	1	1	0	1	1	1
	+36.0dB	0	0	1	1	1	0	0	0
	+35.5dB	0	0	1	1	1	0	0	1
	+35.0dB	0	0	1	1	1	0	1	0
	:	:	:	:	:	:	:	:	:
	+1.5dB	0	1	1	1	1	1	0	1
	+1.0dB	0	1	1	1	1	1	1	0
	+0.5dB	0	1	1	1	1	1	1	1
	0dB	1	0	0	0	0	0	0	0
	Prohibited	1	0	0	0	0	0	0	1
		:	:	:	:	:	:	:	:
		1	1	1	1	1	1	1	

Setting data(hex)="128"-“DVol(Boost)” x 2

Example. DVol(Boost)=36dB, Send data(hex)=128 - (36 x 2)=56(dec)→38(hex)

Select Address 0A00(FL), 0A01(FR), 0A02(RL), 0A03(RR), 0A04(SL), 0A05(SR)(hex)

Function Name	Setting	Fader Volume(FL/FR/RL/RR/SL/SR)							
		MSB D7	D6	D5	D4	D3	D2	D1	LSB D0
Fader Volume [6:0]	-∞dB	1	0	0	0	0	0	0	0
	Prohibited	0	0	0	0	0	0	0	1
		:	:	:	:	:	:	:	:
		0	0	1	1	1	1	0	1
	0dB	0	0	1	1	1	1	1	1
		0	1	0	0	0	0	0	0
	-1dB	0	1	0	0	0	0	0	1
	-2dB	0	1	0	0	0	0	1	0
	-3dB	0	1	0	0	0	0	1	1
	:	:	:	:	:	:	:	:	:
	-78dB	1	1	0	1	1	1	1	0
	-79dB	1	1	0	1	1	1	1	1
	Prohibited	1	1	1	0	0	0	0	0
		1	1	1	0	0	0	0	1
:		:	:	:	:	:	:	:	
		1	1	1	1	1	1	0	
		1	1	1	1	1	1	1	

Setting data(hex)="32" - “Fader Volume”

Example. Fader Volume=-39dB, Send data(hex)=32 - (-39)=71(dec)→47(hex)

Do not send Fader Volume setting data(0A00(hex) to 0A05(hex)[6:0]) during same channel Mixing/Fader Volume Mixing Advanced Switch operation. Fader Volume may malfunction.

Command Specification - Continued

Select Address 1000(hex)

Function Name	Setting	EQ/Tone Coef Selector							
		MSB D7	D6	D5	D4	D3	D2	D1	LSB D0
EQ/Tone Band Selector [3:0]	Band1	0				0	0	0	0
	Band2					0	0	0	1
	Band3					0	0	1	0
	Band4					0	0	1	1
	Band5					0	1	0	0
	Band6					0	1	0	1
	Band7					0	1	1	0
	Band8					0	1	1	1
	Band9					1	0	0	0
	Band10					1	0	0	1
	Band11					1	0	1	0
	Band12					1	0	1	1
	Band13					1	1	0	0
	Bass(Band A)					1	1	0	1
Middle(Band B)	1	1	1	0					
Treble(Band C)	1	1	1	1					
EQ/Tone Ch Selector [6:4]	Front	0	0	0					
	Rear	0	0	1					
	Front/Rear	0	1	0					
	FL	0	1	1					
	FR	1	0	0					
	RL	1	0	1					
	RR	1	1	0					
Prohibited	1	1	1						

Select Address 1001(hex)

Function Name	Setting	EQ/Tone Coef							
		MSB D7	D6	D5	D4	D3	D2	D1	LSB D0
Coefficient b0[7:0]	Coefficient[31:24]	00(hex) to FF(hex)(32bit-Coefficient: High-8bit)(Initial=00(hex))							

Select Address 1002(hex)

Function Name	Setting	EQ/Tone Coef							
		MSB D7	D6	D5	D4	D3	D2	D1	LSB D0
Coefficient b0[7:0]	Coefficient[23:16]	00(hex) to FF(hex)(32bit-Coefficient: MiddleH-8bit)(Initial=00(hex))							

Select Address 1003(hex)

Function Name	Setting	EQ/Tone Coef							
		MSB D7	D6	D5	D4	D3	D2	D1	LSB D0
Coefficient b0[7:0]	Coefficient[15:8]	00(hex) to FF(hex)(32bit-Coefficient: MiddleL-8bit)(Initial=00(hex))							

Select Address 1004(hex)

Function Name	Setting	EQ/Tone Coef							
		MSB D7	D6	D5	D4	D3	D2	D1	LSB D0
Coefficient b0[7:0]	Coefficient[7:0]	00(hex) to FF(hex)(32bit-Coefficient: Low-8bit)(Initial=00(hex))							

Refer to "Filter Coefficient Direct Setup" about the usage of a coefficient.

Coefficients b1, b2, a1, and a2 are setup similarly.

Coef. b1: Select Address: 1005(hex)-Coef[31:24], 1006(hex)-Coef[23:16], 1007(hex)-Coef[15:8], 1008(hex)-Coef[7:0]

Coef. b2: Select Address: 1009(hex)-Coef[31:24], 100A(hex)-Coef[23:16], 100B(hex)-Coef[15:8], 100C(hex)-Coef[7:0]

Coef. a1: Select Address: 100D(hex)-Coef[31:24], 100E(hex)-Coef[23:16], 100F(hex)-Coef[15:8], 1010(hex)-Coef[7:0]

Coef. a2: Select Address: 1011(hex)-Coef[31:24], 1012(hex)-Coef[23:16], 1013(hex)-Coef[15:8], 1014(hex)-Coef[7:0]

Select Address Auto Increment: 1000(hex)→••→1014(hex)→1000(hex)→••→1014(hex)→•••

The DSP filter will reflect the changes after writing in a coefficient a2. (Advanced Switch correspondence)

In case of changing coefficients, five coefficients(b0, b1, b2, a1, a2) have to be setup by sequential order of Select Address.

Though Select Address(1001(hex) to 1014(hex)) are available for both read/write modes, the user cannot read back the selected filter's coefficients through normal procedures since these are common for each band/channel.

These are available with EQ/Tone Coef Read back Setting. (1500(hex))

Command Specification – Continued

Select Address 1100(hex)

Function Name	Setting	(Front/Rear)HPF(A/B)/IIR(A/B) Coef Selector							
		MSB D7	D6	D5	D4	D3	D2	D1	LSB D0
IIR Selector [2:0]	Front HPF A	0	0	0	0	0	0	0	0
	Front HPF B						0	0	1
	Rear HPF A						0	1	0
	Rear HPF B						0	1	1
	Front/Rear HPF A						1	0	0
	Front/Rear HPF B						1	0	1
	IIR A(Surround)						1	1	0
	IIR B(Surround)						1	1	1

Front/Rear HPF are 4th order filters. These are treated as two 2nd order bi-quad filters on direct coef settings, called HPF A and HPF B.

Select Address 1101(hex)

Function Name	Setting	(Front/Rear)HPF(A/B)/IIR(A/B) Coef							
		MSB D7	D6	D5	D4	D3	D2	D1	LSB D0
Coefficient b0[7:0]	Coefficient[31:24]	00(hex) to FF(hex)(32bit-Coefficient: High-8bit) (Initial=00(hex))							

Select Address 1102(hex)

Function Name	Setting	(Front/Rear)HPF(A/B)/IIR(A/B) Coef							
		MSB D7	D6	D5	D4	D3	D2	D1	LSB D0
Coefficient b0[7:0]	Coefficient[23:16]	00(hex) to FF(hex)(32bit-Coefficient: MiddleH-8bit) (Initial=00(hex))							

Select Address 1103(hex)

Function Name	Setting	(Front/Rear)HPF(A/B)/IIR(A/B) Coef							
		MSB D7	D6	D5	D4	D3	D2	D1	LSB D0
Coefficient b0[7:0]	Coefficient[15:8]	00(hex) to FF(hex)(32bit-Coefficient: MiddleL-8bit) (Initial=00(hex))							

Select Address 1104(hex)

Function Name	Setting	(Front/Rear)HPF(A/B)/IIR(A/B) Coef							
		MSB D7	D6	D5	D4	D3	D2	D1	LSB D0
Coefficient b0[7:0]	Coefficient[7:0]	00(hex) to FF(hex)(32bit-Coefficient: Low-8bit) (Initial=00(hex))							

Refer to ["Filter Coefficient Direct Setup"](#) about the usage of a coefficient.

Coefficients b1, b2, a1, and a2 are setup similarly.

Coef. b1: Select Address: 1105(hex)-Coef[31:24], 1106(hex)-Coef[23:16], 1107(hex)-Coef[15:8], 1108(hex)-Coef[7:0]

Coef. b2: Select Address: 1109(hex)-Coef[31:24], 110A(hex)-Coef[23:16], 110B(hex)-Coef[15:8], 110C(hex)-Coef[7:0]

Coef. a1: Select Address: 110D(hex)-Coef[31:24], 110E(hex)-Coef[23:16], 110F(hex)-Coef[15:8], 1110(hex)-Coef[7:0]

Coef. a2: Select Address: 1111(hex)-Coef[31:24], 1112(hex)-Coef[23:16], 1113(hex)-Coef[15:8], 1114(hex)-Coef[7:0]

Select Address Auto Increment: 1100(hex)→••→1114(hex)→1100(hex)→••→1114(hex)→•••

The DSP filter will reflect the changes after writing in a coefficient a2. (Advanced Switch correspondence)

In case of changing coefficients, five coefficients(b0, b1, b2, a1, a2) have to be setup by sequential order of Select Address.

Though Select Address(1101(hex) to 1114(hex)) are available for both read/write modes, the user cannot read back the selected filter's coefficients through normal procedures since these are common for each band/channel.

These are available with IIR Coef Read back Setting. (1501(hex))

Command Specification - Continued

Select Address 1200(hex)

Function Name	Setting	Loudness Coef Selector								LSB
		D7	D6	D5	D4	D3	D2	D1	D0	
Filter Selector[0]	LPF	0	0	0	0	0	0	0	0	0
	HPF	0	0	0	0	0	0	0	0	1

Select Address 1201(hex)

Function Name	Setting	Loudness Coef								LSB
		D7	D6	D5	D4	D3	D2	D1	D0	
Coefficient b0[7:0]	Coefficient[23:16]	00(hex) to FF(hex)(24bit-Coefficient: High-8bit)(Initial=00(hex))								

Select Address 1202(hex)

Function Name	Setting	Loudness Coef								LSB
		D7	D6	D5	D4	D3	D2	D1	D0	
Coefficient b0[7:0]	Coefficient[15:8]	00(hex) to FF(hex)(24bit-Coefficient: Middle-8bit)(Initial=00(hex))								

Select Address 1203(hex)

Function Name	Setting	Loudness Coef								LSB
		D7	D6	D5	D4	D3	D2	D1	D0	
Coefficient b0[7:0]	Coefficient[7:0]	00(hex) to FF(hex)(24bit-Coefficient: Low-8bit)(Initial=00(hex))								

Refer to ["Filter Coefficient Direct Setup"](#) about the usage of a coefficient.

Coefficients b1, b2, a1, and a2 are setup similarly.

Coef. b1: Select Address: 1204(hex)-Coef[23:16], 1205(hex)-Coef[15:8], 1206(hex)-Coef[7:0]

Coef. b2: Select Address: 1207(hex)-Coef[23:16], 1208(hex)-Coef[15:8], 1209(hex)-Coef[7:0]

Coef. a1: Select Address: 120A(hex)-Coef[23:16], 120B(hex)-Coef[15:8], 120C(hex)-Coef[7:0]

Coef. a2: Select Address: 120D(hex)-Coef[23:16], 120E(hex)-Coef[15:8], 120F(hex)-Coef[7:0]

The DSP filter will reflect the changes after writing in a coefficient a2. (Advanced Switch correspondence only Gain switching)

In case of changing coefficients, five coefficients(b0, b1, b2, a1, a2) have to be setup by sequential order of Select Address.

Though Select Address(1201(hex) to 120F(hex)) are available for both read/write modes, the user cannot read back the selected filter's coefficients through normal procedures since these are common for each band/channel.

These are available with IIR Coef Read back Setting. (1501(hex))

Select Address 1211(hex)

Function Name	Setting	Loudness HiBoost Coef								LSB
		D7	D6	D5	D4	D3	D2	D1	D0	
Coefficient h[7:0]	Coefficient[15:8]	00(hex) to FF(hex)(16bit-Coefficient: High-8bit)(Initial=00(hex))								

Select Address 1212(hex)

Function Name	Setting	Loudness HiBoost Coef								LSB
		D7	D6	D5	D4	D3	D2	D1	D0	
Coefficient h[7:0]	Coefficient[7:0]	00(hex) to FF(hex)(16bit-Coefficient: Low-8bit)(Initial=00(hex))								

It is reflected to DSP filter after writing in a Low-8bit.

Select Address 1213(hex)

Function Name	Setting	Loudness Gain Coef								LSB
		D7	D6	D5	D4	D3	D2	D1	D0	
Coefficient g[7:0]	Coefficient[15:8]	00(hex) to FF(hex)(16bit-Coefficient: High-8bit)(Initial=00(hex))								

Select Address 1214(hex)

Function Name	Setting	Loudness Gain Coef								LSB
		D7	D6	D5	D4	D3	D2	D1	D0	
Coefficient g[7:0]	Coefficient[7:0]	00(hex) to FF(hex)(16bit-Coefficient: Low-8bit)(Initial=00(hex))								

Select Address Auto increment: 1211(hex)→••→1214(hex)→1211(hex)→

Command Specification - Continued

Select Address 1300(hex)

Function Name	Setting	Sub IIR Coef Selector							
		MSB D7	D6	D5	D4	D3	D2	D1	LSB D0
IIR Selector [2:0]	Sub HPF A	0	0	0	0	0	0	0	0
	Sub HPF B						0	0	1
	Sub LPF A						0	1	0
	Sub LPF B						0	1	1
	Sub IIR						1	0	0
	Prohibited						1	0	1
						1	1	1	

Sub HPF/LPF are 4th order filters. These are treated as two 2nd order bi-quad filters on direct coef settings, called A and B.

Select Address 1301(hex)

Function Name	Setting	Sub IIR Coef							
		MSB D7	D6	D5	D4	D3	D2	D1	LSB D0
Coefficient b0[7:0]	Coefficient[31:24]	00(hex) to FF(hex)(32bit-Coefficient: High-8bit)(Initial=00(hex))							

Select Address 1302(hex)

Function Name	Setting	Sub IIR Coef							
		MSB D7	D6	D5	D4	D3	D2	D1	LSB D0
Coefficient b0[7:0]	Coefficient[23:16]	00(hex) to FF(hex)(32bit-Coefficient: MiddleH-8bit)(Initial=00(hex))							

Select Address 1303(hex)

Function Name	Setting	Sub IIR Coef							
		MSB D7	D6	D5	D4	D3	D2	D1	LSB D0
Coefficient b0[7:0]	Coefficient[15:8]	00(hex) to FF(hex)(32bit-Coefficient: MiddleL-8bit)(Initial=00(hex))							

Select Address 1304(hex)

Function Name	Setting	Sub IIR Coef							
		MSB D7	D6	D5	D4	D3	D2	D1	LSB D0
Coefficient b0[7:0]	Coefficient[7:0]	00(hex) to FF(hex) (32bit-Coefficient: Low-8bit)(Initial=00(hex))							

Refer to ["Filter Coefficient Direct Setup"](#) about the usage of a coefficient.

Coefficients b1, b2, a1, and a2 are setup similarly.

Coef. b1: Select Address: 1305(hex)-Coef[31:24], 1306(hex)-Coef[23:16], 1307(hex)-Coef[15:8], 1308(hex)-Coef[7:0]

Coef. b2: Select Address: 1309(hex)-Coef[31:24], 130A(hex)-Coef[23:16], 130B(hex)-Coef[15:8], 130C(hex)-Coef[7:0]

Coef. a1: Select Address: 130D(hex)-Coef[31:24], 130E(hex)-Coef[23:16], 130F(hex)-Coef[15:8], 1310(hex)-Coef[7:0]

Coef. a2: Select Address: 1311(hex)-Coef[31:24], 1312(hex)-Coef[23:16], 1313(hex)-Coef[15:8], 1314(hex)-Coef[7:0]

Select Address Auto increment: 1300(hex)→••→1314(hex)→1300(hex)→••→1314(hex)→•••

The DSP filter will reflect the changes after writing in a coefficient a2. (Advanced Switch correspondence)

In case of changing coefficients, five coefficients(b0, b1, b2, a1, a2) have to be setup by sequential order of Select Address.

Though Select Address(1301(hex) to 1314(hex)) are available for both read/write modes, the user cannot read back the selected filter's coefficients through normal procedures since these are common for each band/channel.

These are available with IIR Coef Read back Setting. (1501(hex))

Command Specification - Continued

Select Address 1400(hex)

Function Name	Setting	BEEP Coef							
		MSB	D7	D6	D5	D4	D3	D2	D1
Sine Wave Coef b1[7:0]	Coefficient[23:16]	00(hex) to FF(hex)(24bit-Coefficient: High-8bit)(Initial=00(hex))							

Select Address 1401(hex)

Function Name	Setting	BEEP Coef							
		MSB	D7	D6	D5	D4	D3	D2	D1
Sine Wave Coef b1[7:0]	Coefficient[15:8]	00(hex) to FF(hex)(24bit-Coefficient: Middle-8bit)(Initial=00(hex))							

Select Address 1402(hex)

Function Name	Setting	BEEP Coef							
		MSB	D7	D6	D5	D4	D3	D2	D1
Sine Wave Coef b1[7:0]	Coefficient[7:0]	00(hex) to FF(hex)(24bit-Coefficient: Low-8bit)(Initial=00(hex))							

Refer to ["Filter Coefficient Direct Setup"](#) about the usage of a coefficient.

Select Address 1403(hex)

Function Name	Setting	BEEP Coef							
		MSB	D7	D6	D5	D4	D3	D2	D1
Sine Wave Coef a1[7:0]	Coefficient[23:16]	00(hex) to FF(hex)(24bit-Coefficient: High-8bit)(Initial=00(hex))							

Select Address 1404(hex)

Function Name	Setting	BEEP Coef							
		MSB	D7	D6	D5	D4	D3	D2	D1
Sine Wave Coef a1[7:0]	Coefficient[15:8]	00(hex) to FF(hex)(24bit-Coefficient: Middle-8bit)(Initial=00(hex))							

Select Address 1405(hex)

Function Name	Setting	BEEP Coef							
		MSB	D7	D6	D5	D4	D3	D2	D1
Sine Wave Coef a1[7:0]	Coefficient[7:0]	00(hex) to FF(hex)(24bit-Coefficient: Low-8bit)(Initial=00(hex))							

Refer to ["Filter Coefficient Direct Setup"](#) about the usage of a coefficient.

Command Specification - Continued

Select Address 1406(hex)

Function Name	Setting	BEEP ON time Coef1						LSB	
		D7	D6	D5	D4	D3	D2	D1	D0
ON time Coef[1:0]	Coefficient[17:16]	0	0	0	0	0	0	00(hex) to 03(hex) (18bit-Coefficient:High-2bit) (Initial=00(hex))	

Select Address 1407(hex)

Function Name	Setting	BEEP ON time Coef2							
		D7	D6	D5	D4	D3	D2	D1	D0
ON time Coef[7:0]	Coefficient[15:8]	00(hex) to FF(hex)(18bit-Coefficient: Middle-8bit)(Initial=00(hex))							

Select Address 1408(hex)

Function Name	Setting	BEEP ON time Coef2							
		D7	D6	D5	D4	D3	D2	D1	D0
ON time Coef[7:0]	Coefficient[7:0]	00(hex) to FF(hex)(18bit-Coefficient: Low-8bit)(Initial=00(hex))							

Refer to ["Filter Coefficient Direct Setup"](#) about the usage of a coefficient.

Select Address 1409(hex)

Function Name	Setting	BEEP OFF time Coef1						LSB	
		D7	D6	D5	D4	D3	D2	D1	D0
OFF time Coef[1:0]	Coefficient[17:16]	0	0	0	0	0	0	00(hex) to 03(hex) (18bit-Coefficient:High-2bit) (Initial=00(hex))	

Select Address 140A(hex)

Function Name	Setting	BEEP OFF time Coef2							
		D7	D6	D5	D4	D3	D2	D1	D0
OFF time Coef[7:0]	Coefficient[15:8]	00(hex) to FF(hex)(18bit-Coefficient: Middle-8bit)(Initial=00(hex))							

Select Address 140B(hex)

Function Name	Setting	BEEP OFF time Coef2							
		D7	D6	D5	D4	D3	D2	D1	D0
OFF time Coef[7:0]	Coefficient[7:0]	00(hex) to FF(hex)(18bit-Coefficient: Low-8bit)(Initial=00(hex))							

Refer to ["Filter Coefficient Direct Setup"](#) about the usage of a coefficient.

Command Specification - Continued

Select Address 1500(hex)

Function Name	Setting	EQ/Tone Coef Read back Setting							
		MSB D7	D6	D5	D4	D3	D2	D1	LSB D0
EQ/Tone Band Selector [3:0]	Band1	0	0			0	0	0	0
	Band2					0	0	0	1
	Band3					0	0	1	0
	Band4					0	0	1	1
	Band5					0	1	0	0
	Band6					0	1	0	1
	Band7					0	1	1	0
	Band8					0	1	1	1
	Band9					1	0	0	0
	Band10					1	0	0	1
	Band11					1	0	1	0
	Band12					1	0	1	1
	Band13					1	1	0	0
	Bass(Band A)					1	1	0	1
Middle(Band B)	1	1	1	0					
Treble(Band C)	1	1	1	1					
EQ/Tone Ch Selector [5:4]	FL			0	0				
	FR			0	1				
	RL			1	0				
	RR			1	1				

When the command is sent, the coefficients of selected band are loaded to registers(Select Address 1001(hex) to 1014(hex)) from Coef RAM. When the data is written to each band and also during the data is being loaded to registers, Coef IO Status (EQ)(A053(hex)[3])=Busy. After Coef IO Status (EQ) becomes "Done", coefficients can be read from registers(Select Address 1001(hex) to 1014(hex)).

Select Address 1501(hex)

Function Name	Setting	IIR Coef Read back Setting							
		MSB D7	D6	D5	D4	D3	D2	D1	LSB D0
(Front/Rear)HPF/IIR(A/B) Selector [2:0]	Front HPF A	0					0	0	0
	Front HPF B						0	0	1
	Rear HPF A						0	1	0
	Rear HPF B						0	1	1
	IIR A(Surround)						1	0	0
	IIR B(Surround)						1	0	1
	Prohibited						1	1	0
Loudness Filter Selector[3]	LPF					0			
	HPF					1			
Sub IIR Selector [6:4]	Sub HPF A		0	0	0				
	Sub HPF B		0	0	1				
	Sub LPF A		0	1	0				
	Sub LPF B		0	1	1				
	Sub IIR		1	0	0				
	Prohibited		1	0	1				
			1	1	0				
			1	1	1				

When the command is sent, coefficients of selected filters are loaded to registers (Select Address 1101(hex) to 1114(hex)/1201(hex) to 120F(hex)/1301(hex) to 1314(hex)) from Coef RAM. When the data is written to each band and also during the data is being loaded to registers, Coef IO Status(Front/Rear/A/B, Loudness, Sub) (A053(hex)[2:0])=Busy. After Coef IO Status (Front/Rear/A/B, Loudness, Sub)(A053(hex)[2:0]) become "Done", coefficients can be read from registers (Select Address 1101(hex) to 1114(hex)/1201(hex) to 120F(hex)/1301(hex) to 1314(hex)).

Command Specification - Continued

Select Address A000(hex), Read ONLY

Function Name	Setting	Spectrum Analyzer Status								MSB	LSB
		D7	D6	D5	D4	D3	D2	D1	D0		
Output Level High(Band1)[7:0]	Output Level	16bit: High-8bit[15:8]									

Select Address A001(hex), Read ONLY

Function Name	Setting	Spectrum Analyzer Status								MSB	LSB
		D7	D6	D5	D4	D3	D2	D1	D0		
Output Level Low(Band1)[7:0]	Output Level	16bit: Low-8bit[7:0]									

The Spectrum Analyzer Output (16bits data) from Band1 to Band16 can be read in A000(hex) to A01F(hex).
When peak hold operated, the peak value of each band is reset after read-out.

Spectrum Analyzer Select Address(hex)

Band	SpeAna level		Band	SpeAna level		Band	SpeAna level		Band	SpeAna level	
	[15:8]	[7:0]		[15:8]	[7:0]		[15:8]	[7:0]		[15:8]	[7:0]
1	A000	A001	5	A008	A009	9	A010	A011	13	A018	A019
2	A002	A003	6	A00A	A00B	10	A012	A013	14	A01A	A01B
3	A004	A005	7	A00C	A00D	11	A014	A015	15	A01C	A01D
4	A006	A007	8	A00E	A00F	12	A016	A017	16	A01E	A01F

Select Address A040(Input1), A044(Input3)(hex), Read ONLY

Function Name	Setting	S/PDIF Status1(Input1/Input3)								MSB	LSB																											
		D7	D6	D5	D4	D3	D2	D1	D0																													
Emphasis [0]	No Emphasis	0	0	0	0						0																											
	Pre Emphasis										1																											
Copyright [1]	Copyright																			0																		
	No Copyright																			1																		
Format [2]	Linear PCM																												0									
	Other																												1									
Application [3]	Consumer																																					0
	Professional																																					1

S/PDIF Status setup time=(1/f_s x 192 x 2)ms

Select Address A041(Input1), A045(Input3)(hex), Read ONLY

Function Name	Setting	S/PDIF Status2(Input1/Input3)								MSB	LSB
		D7	D6	D5	D4	D3	D2	D1	D0		
Category [7:0]	00(hex) to FF(hex)	Category[7:0]									

S/PDIF Status setup time=(1/f_s x 192 x 2)ms

Command Specification - Continued

Select Address A042(Input1), A046(Input3)(hex), Read ONLY

Function Name	Setting	MSB		S/PDIF Status3(Input1/Input3)				LSB		
		D7	D6	D5	D4	D3	D2	D1	D0	
Sampling Frequency [3:0]	44.1kHz					0	0	0	0	
	88.2kHz					0	0	0	1	
	22.05kHz					0	0	1	0	
	176.4kHz					0	0	1	1	
	48kHz					0	1	0	0	
	96kHz					0	1	0	1	
	24kHz					0	1	1	0	
	192kHz					0	1	1	1	
	Not indicated						1	0	0	0
							1	0	0	1
							1	0	1	1
	32kHz					1	1	0	0	
	Not indicated						1	1	0	1
						1	1	1	0	
						1	1	1	1	
Original Sampling Frequency [7:4]	Not indicated	0	0	0	0					
	16kHz	0	0	0	1					
	Reserved	0	0	1	0					
	32kHz	0	0	1	1					
	12kHz	0	1	0	0					
	11.025kHz	0	1	0	1					
	8kHz	0	1	1	0					
	Reserved	0	1	1	1					
	192kHz	1	0	0	0					
	24kHz	1	0	0	1					
	96kHz	1	0	1	0					
	48kHz	1	0	1	1					
	176.4kHz	1	1	0	0					
	22.05kHz	1	1	0	1					
88.2kHz	1	1	1	0						
44.1kHz	1	1	1	1						

S/PDIF Status setup time=(1/f_s x 192 x 2)ms

Select Address A043(Input1), A047(Input3)(hex), Read ONLY

Function Name	Setting	MSB		S/PDIF Status4(Input1/Input3)				LSB			
		D7	D6	D5	D4	D3	D2	D1	D0		
Word Length [3:0]	Not Indicated					0	0	0	0		
	19bits					0	0	0	1		
	18bits					0	0	1	0		
	17bits					0	0	1	1		
	16bits					0	1	0	0		
	20bits					0	1	0	1		
	Reserved						0	1	1	0	
							0	1	1	1	
	Not Indicated					1	0	0	0		
	23bits	0	0			1	0	0	1		
	22bits					1	0	1	0		
	21bits					1	0	1	1		
	20bits					1	1	0	0		
	24bits					1	1	0	1		
	Reserved							1	1	1	0
							1	1	1	1	
							1	1	1	1	
Clock Accuracy [5:4]	Level II					0	0				
	Level III					0	1				
	Level I			1	0						
	Not Indicated			1	1						

S/PDIF Status setup time=(1/f_s x 192 x 2)ms

Command Specification - Continued

Select Address A051(hex), Read ONLY

Function Name	Setting	Sync Status																			
		MSB D7	D6	D5	D4	D3	D2	D1	LSB D0												
Sync(Input3) [0]	Normal	0	0	0	0	0		0	0												
	Sync Error								1												
Sync(ExtIO) [1]	Normal								0	0	0	0		0	0						
	Sync Error														1						
Sync(Input1) [2]	Normal														0	0	0	0		0	0
	Sync Error																				1

Select Address A053(hex), Read ONLY

Function Name	Setting	Coef IO Status																					
		MSB D7	D6	D5	D4	D3	D2	D1	LSB D0														
Sub [0]	Done	0	0	0	0			0	0														
	Busy								1														
Front/Rear/A/B [1]	Done								0	0	0	0			0	0							
	Busy															1							
Loudness Filter [2]	Done															0	0	0	0			0	0
	Busy																						1
EQ [3]	Done	0	0	0	0			0															0
	Busy																						1

Coef IO Status is set to Busy when the coefficients are written to RAM, and the coefficients are load from RAM to a register.

Select Address D000(hex)

Function Name	Setting	Read Back Address1							
		MSB D7	D6	D5	D4	D3	D2	D1	LSB D0
Base Address(High) [7:0]	Address	Initial=00(hex)							

Read start Address when reading the register(upper byte).

Select Address D001(hex)

Function Name	Setting	Read Back Address2							
		MSB D7	D6	D5	D4	D3	D2	D1	LSB D0
Base Address(Low) [7:0]	Address	Initial=00(hex)							

Read start Address when reading the register(lower byte).

Select Address FEFE(hex)

Function Name	Setting	System Reset							
		MSB D7	D6	D5	D4	D3	D2	D1	LSB D0
System Reset [7:0]	Normal	0	0	0	0	0	0	0	0
	Reset	1	0	0	0	0	0	0	1

By 81(hex) setup, the logic sections other than Command I/F are reset.

Application Example

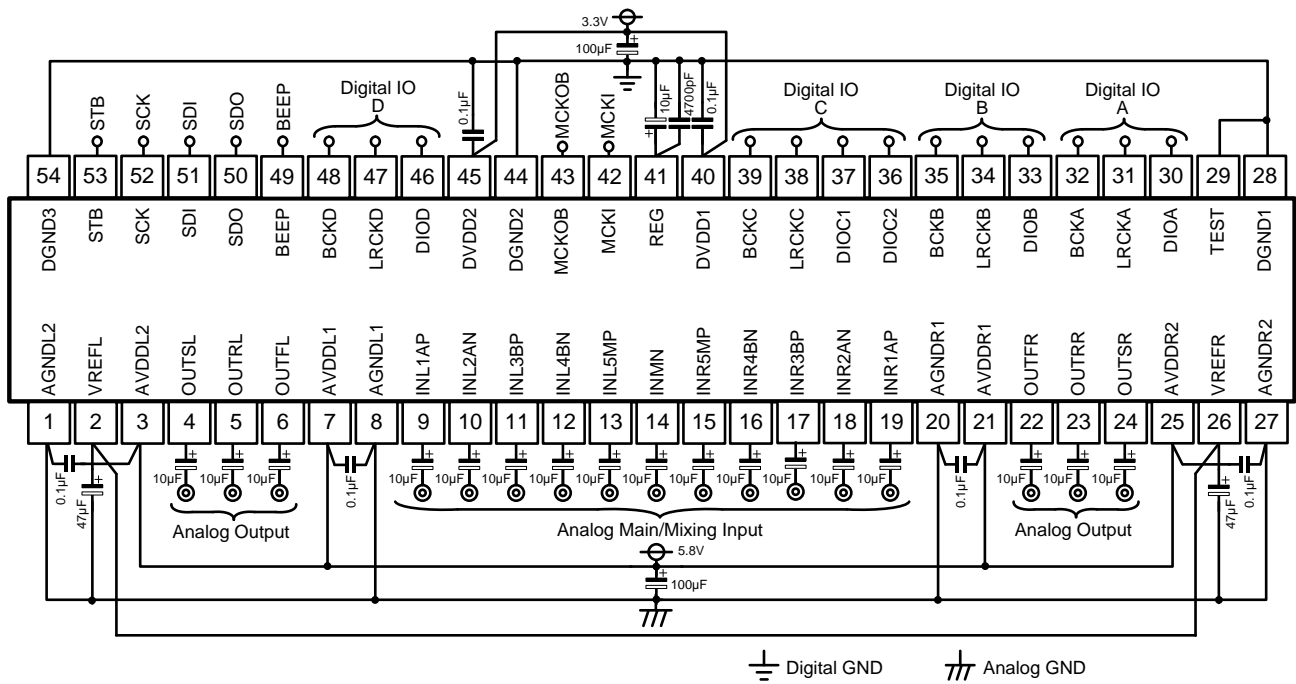
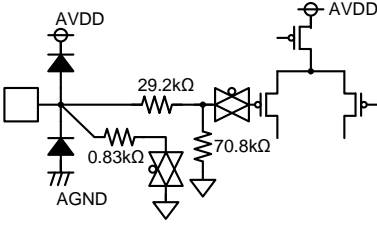
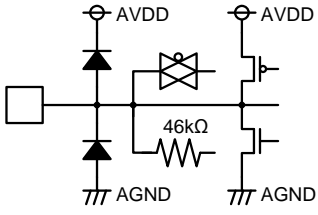
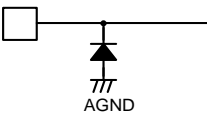
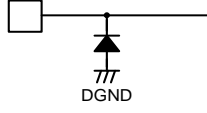
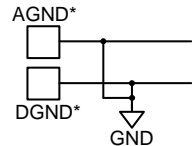
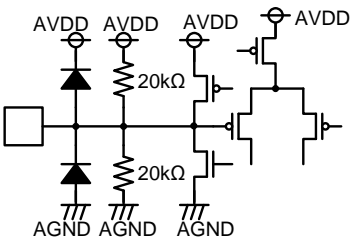
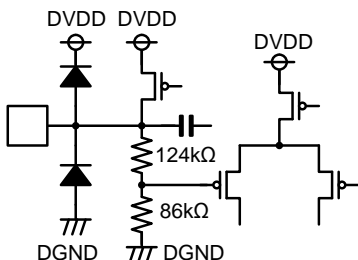

Figure 101. Application Example

External Parts •Capacitor: ±5%
About Digital Power Supply DVDD1/DVDD2 are equal to supply voltage(Recommended operating condition: 3.0V to 3.6V) of the microcontroller.
Notes on wiring 1 .Decoupling capacitor of a power supply has to be connected to VDD and GND in the shortest distance possible. 2. Lines of AGND should be connected in one point only. 3. Digital Wiring Pattern of Digital shall be far from that of analog unit and see to it that there will be no crosstalk. 4. If possible, serial control lines should not be parallel. If they are adjacent to each other, the lines have to be shielded. 5. If possible, Lines of Analog Input should not be parallel. If they are adjacent to each other, the lines have to be shielded. 6. Connect the TEST pin to the DGND1 pin.

I/O Equivalence Circuit

Pin No.	Pin Name	Pin Voltage	Equivalent Circuit	Pin Description
9 19 10 18 11 17 12 16 13 15 14	INL1AP INR1AP INL2AN INR2AN INL3BP INR3BP INL4BN INR4BN INL5MP INR5MP INMN	2.9V		Analog Input Pin
4 22 5 23 6 24	OUTSL OUTFR OUTRL OUTRR OUTFL OUTSR	2.9V		Analog Output Pin
3 25 7 21	AVDDL2 AVDDR2 AVDDL1 AVDDR1	5.8V		Power Supply Pin
40 45	DVDD1 DVDD2	3.3V		
1 27 8 20 28 44 54	AGNDL2 AGNDR2 AGNDL1 AGNDR1 DGND1 DGND2 DGND3	0V		Ground Pin
2 26	VREFL VREFR	2.9V		Analog Reference Voltage Output Pin
41	REG	1.5V		Built-in Regulator Output Pin

The figures in the pin explanation and input/output equivalent circuit is reference value, it doesn't guarantee the value.

I/O Equivalence Circuit - Continued

Pin No.	Pin Name	Pin Voltage	Equivalent Circuit	Pin Description
29 49	TEST BEEP	0V/3.3V		Digital Input Pin
42 43	MCKI MCKOB	0V/3.3V		Master Clock Input Pin/Output Pin
30 31 32 33 34 35 36 37 38 39 46 47 48	DIOA LRCKA BCKA DIOB LRCKB BCKB DIOC2 DIOC1 LRCKC BCKC DIOD LRCKD BCKD	0V/3.3V		Digital Input/Output Pin
50	SDO	0V/3.3V		Digital Output Pin
51	SDI	0V/3.3V		Control Signal Input/Output Pin
52 53	SCK STB	0V/3.3V		Control Signal Input Pin

The figures in the pin explanation and input/output equivalent circuit is reference value, it doesn't guarantee the value.

Application Information

(1) Absolute Maximum Rating Voltage

If you apply voltage to AVDD*(Note 1) or DVDD*(Note 2) beyond the absolute maximum rating voltage, the circuit current rapidly increases. This may lead to characteristics deterioration or destruction of the device. When surge is expected to be applied to AVDD*(Note 1) or DVDD*(Note 2), like in a surge test, precautions must be taken so that the absolute maximum rating voltage will not be exceeded, even by the combined operating voltage and surge pulse level.

(Note 1) AVDD*=AVDDL1, AVDDL2, AVDDR1, AVDDR2

(Note 2) DVDD*=DVDD1, DVDD2

(2) About the Signal Input Pins

About the constant setting of input coupling capacitor

In the signal input pin, the value for the input coupling capacitor C has to be sufficient enough for the input impedance. R_{IN} inside the IC. This will determine the primary HPF characteristics of the RC.

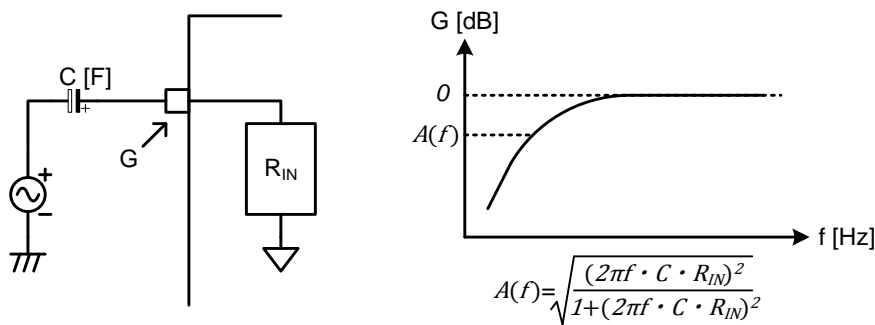

Figure 102. The primary HPF characteristics of the RC

About the Input Selector SHORT

SHORT Mode is the command which reduces input impedance of all pins Analog Input Selector VREFL and VREFR. The charge time of external coupling capacitors become short with this command. Use this command at power up/power down.

(3) The REG Pin External Capacitor

The charging current flows to an external capacitor of the REG pin during power-up. The recommended value of an external capacitor is 10μF to 47μF for preventing large current.

(4) Circuit Current

Maximum Analog/Digital Circuit Current must have a margin of over 10% from Electrical Characteristic Limit, considering operation supply voltage range and operation temperature range. For Maximum Digital Circuit Current, the charging current to an external capacitor of the REG pin should be considered.

(5) Mixing(Bias Circuit for Mixing)

All amplifier bias for Mixing is connected from the buffer amplifier of the VREFR pin(Pin 26) voltage. Since AVol(DMix) is connected from the Rch side DAC, bias of mixing circuit comes from VREFR by the Rch side. Therefore, although DC offset potential difference between VREFL-VREFR occurs, if the external short-circuit of both pins is carried out, DC offset difference is reduced.

Application Information - Continued

(6) Power Supply Sequence for Start-up and Shut Down

Power supply start-up sequence

MUTE-ON → DVDD-ON → Input MCK → AVDD-ON → System Reset → Input serial data and audio data → MUTE-OFF

Power supply shut down sequence

MUTE Analog Output → MUTE-ON → Stop serial data and audio data → Stop MCK → AVDD-OFF → DVDD-OFF

Sound MUTE is needed to prevent pop noise.

<<Power Supply Start-up Sequence>>

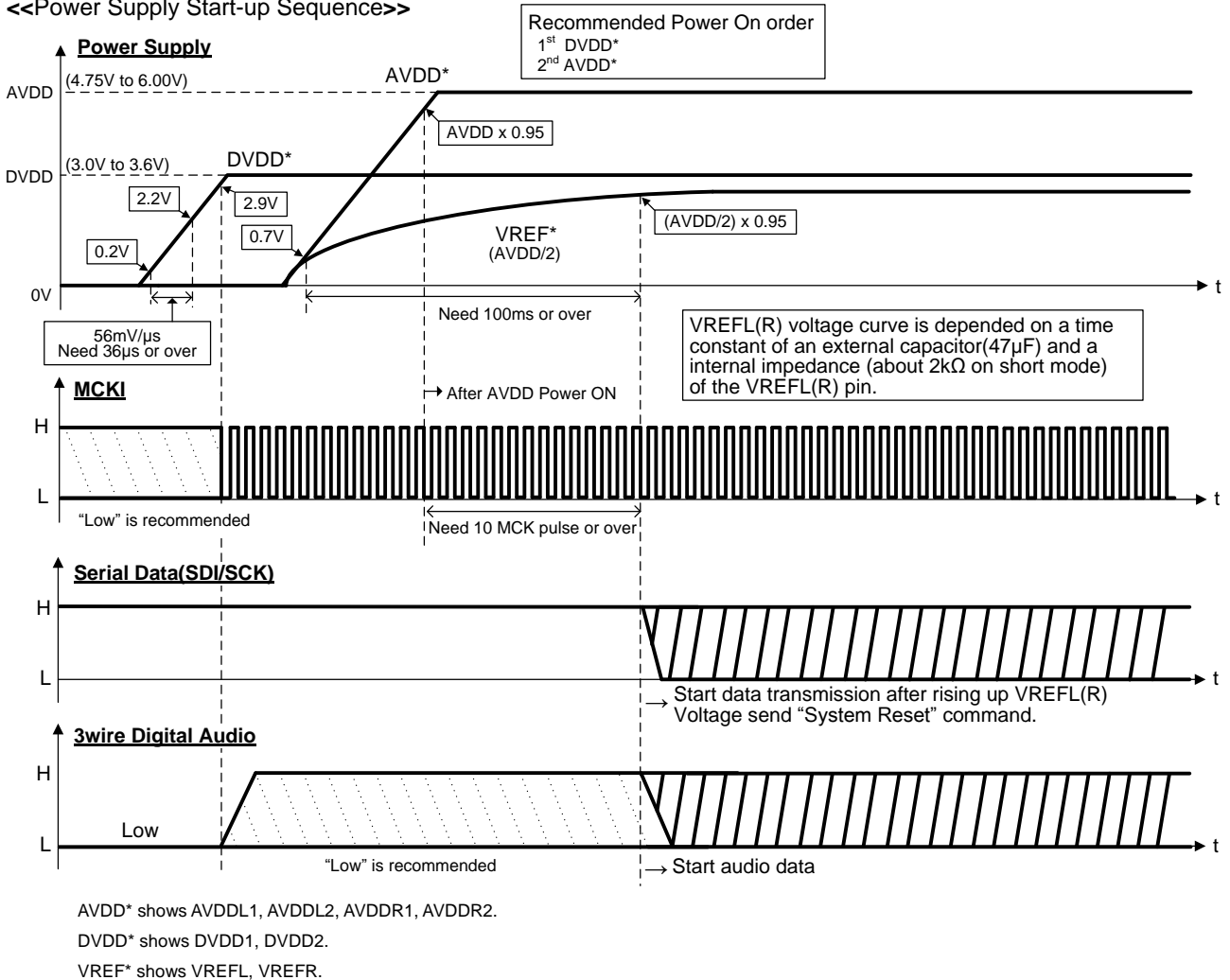

Figure 103. Power Supply start-up sequence

Send "System Reset" and "data to all Select Address(as initial data)" when power supply starts up from lower than the recommended supply voltage(AVDD=4.75V to 6.0V, DVDD=3.0V to 3.6V).

Sound MUTE is needed to prevent pop noise until the initial data has been sent.

<Initialization>

- (1) Send RESET("System Reset" command)
- (2) Send Initial Setup
- (3) Send all data without Fader Volume
- (4) Send all Fader Volume

Application Information - Continued

<<Power Supply Shut Down Sequence>>

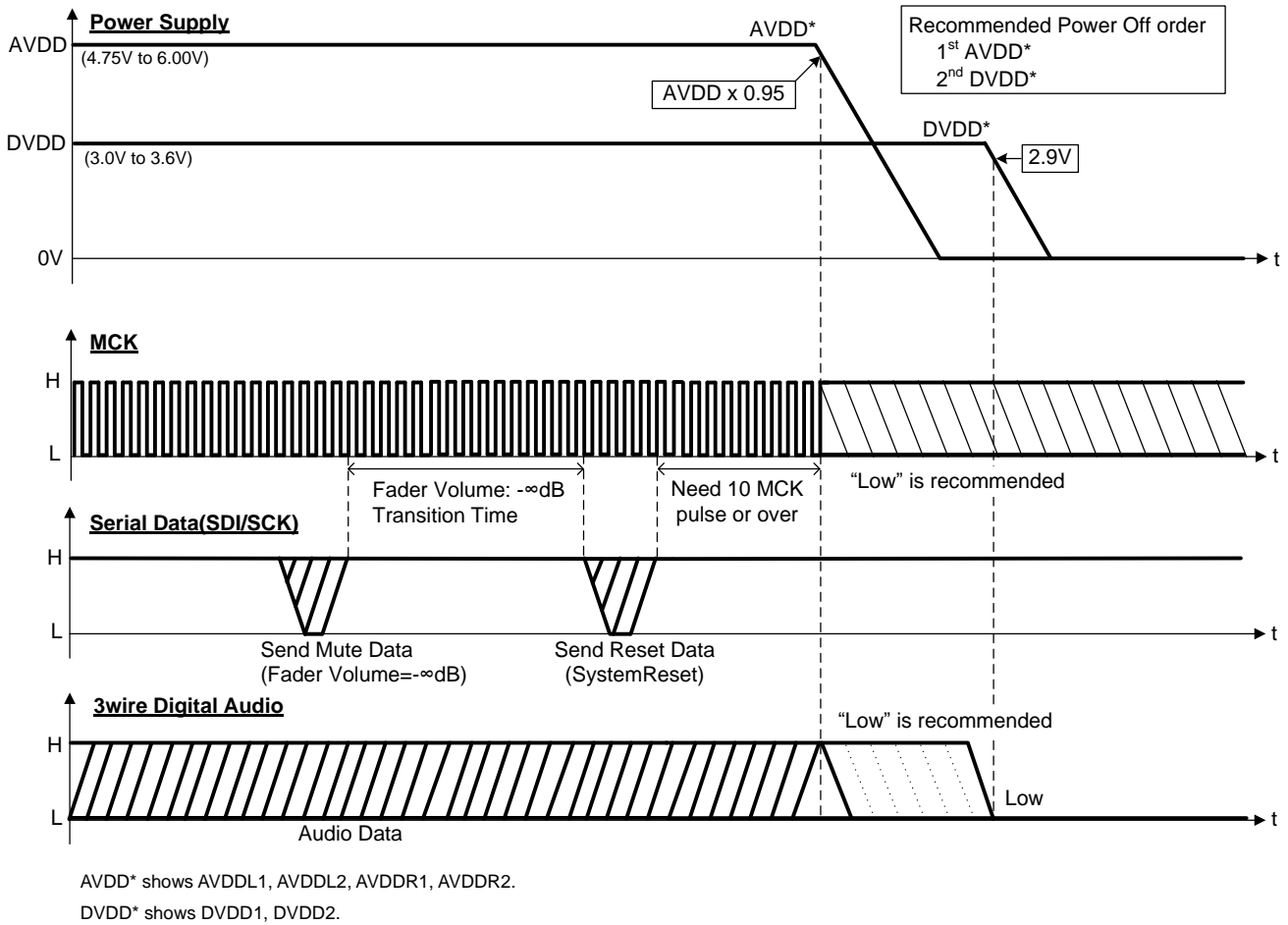

Figure 104. Power Supply shut down sequence

Send the data(first Fader Volume=-∞dB, then System Reset) when power supply is reduced to lower than the recommended supply voltage(AVDD=4.75V to 6.0V, DVDD=3.0V to 3.6V). Sound MUTE is needed to prevent pop noise.

<Shut down>

- (1) Send Fader Volume=-∞dB data(Select Address 0A00(hex) to 0A05(hex))
- (2) Send RESET After Fader Volume=-∞dB.

(7) RAM Clear

The processing time of "RAM clear" is 15μs. Set the register value to "Normal" before using the DSP functions. Data RAMs must be cleared when audio data format changed in addition to the time of DSP initialization. After executing RAM Clear, all filters have to be setup again.

(8) Input-and-Output Delay

The Time Alignment time($f_s=48kHz$) in each signal path is the following. ExtIO is not to be used. The Time Alignment value is set to 0ms.

- Analog Input → Analog Output: $(Input_Selector_ADC) + (DAC_Fader\ OUT) = 0.41 + 0.96 = 1.37$ [ms]
- Digital Input → Analog Output: $(SRC) + (DAC_Fader\ OUT) = 0.86 + 0.96 = 1.82$ [ms]
- Analog Input → Digital Output: $(Input_Selector_ADC) = 0.41$ [ms]
- Digital Input → Digital Output: $(SRC) = 0.86$ [ms]

Operational Notes

1. Reverse Connection of Power Supply

Connecting the power supply in reverse polarity can damage the IC. Take precautions against reverse polarity when connecting the power supply, such as mounting an external diode between the power supply and the IC's power supply pins.

2. Power Supply Lines

Design the PCB layout pattern to provide low impedance supply lines. Separate the ground and supply lines of the digital and analog blocks to prevent noise in the ground and supply lines of the digital block from affecting the analog block. Furthermore, connect a capacitor to ground at all power supply pins. Consider the effect of temperature and aging on the capacitance value when using electrolytic capacitors.

3. Ground Voltage

Ensure that no pins are at a voltage below that of the ground pin at any time, even during transient condition.

4. Ground Wiring Pattern

When using both small-signal and large-current ground traces, the two ground traces should be routed separately but connected to a single ground at the reference point of the application board to avoid fluctuations in the small-signal ground caused by large currents. Also ensure that the ground traces of external components do not cause variations on the ground voltage. The ground lines must be as short and thick as possible to reduce line impedance.

5. Thermal Consideration

Should by any chance the maximum junction temperature rating be exceeded the rise in temperature of the chip may result in deterioration of the properties of the chip. In case of exceeding this absolute maximum rating, increase the board size and copper area to prevent exceeding the maximum junction temperature rating.

6. Recommended Operating Conditions

These conditions represent a range within which the expected characteristics of the IC can be approximately obtained. The electrical characteristics are guaranteed under the conditions of each parameter.

7. Inrush Current

When power is first supplied to the IC, it is possible that the internal logic may be unstable and inrush current may flow instantaneously due to the internal powering sequence and delays, especially if the IC has more than one power supply. Therefore, give special consideration to power coupling capacitance, power wiring, width of ground wiring, and routing of connections.

8. Operation Under Strong Electromagnetic Field

Operating the IC in the presence of a strong electromagnetic field may cause the IC to malfunction.

9. Testing on Application Boards

When testing the IC on an application board, connecting a capacitor directly to a low-impedance output pin may subject the IC to stress. Always discharge capacitors completely after each process or step. The IC's power supply should always be turned off completely before connecting or removing it from the test setup during the inspection process. To prevent damage from static discharge, ground the IC during assembly and use similar precautions during transport and storage.

10. Inter-pin Short and Mounting Errors

Ensure that the direction and position are correct when mounting the IC on the PCB. Incorrect mounting may result in damaging the IC. Avoid nearby pins being shorted to each other especially to ground, power supply and output pin. Inter-pin shorts could be due to many reasons such as metal particles, water droplets (in very humid environment) and unintentional solder bridge deposited in between pins during assembly to name a few.

11. Unused Input Pins

Input pins of an IC are often connected to the gate of a MOS transistor. The gate has extremely high impedance and extremely low capacitance. If left unconnected, the electric field from the outside can easily charge it. The small charge acquired in this way is enough to produce a significant effect on the conduction through the transistor and cause unexpected operation of the IC. So unless otherwise specified, unused input pins should be connected to the power supply or ground line.

Operational Notes - Continued**12. Regarding the Input Pin of the IC**

In the construction of this IC, P-N junctions are inevitably formed creating parasitic diodes or transistors. The operation of these parasitic elements can result in mutual interference among circuits, operational faults, or physical damage. Therefore, conditions which cause these parasitic elements to operate, such as applying a voltage to an input pin lower than the ground voltage should be avoided. Furthermore, do not apply a voltage to the input pins when no power supply voltage is applied to the IC. Even if the power supply voltage is applied, make sure that the input pins have voltages within the values specified in the electrical characteristics of this IC.

13. Ceramic Capacitor

When using a ceramic capacitor, determine the dielectric constant considering the change of capacitance with temperature and the decrease in nominal capacitance due to DC bias and others.

Abbreviations

Acronym	Description
ADC	Analog-to-Digital Converter
Att	Attenuation
AMix	Analog Mixing
AVol	Analog Volume
BPF	Band-Pass Filter
CD	Compact Disc
Coef	Coefficient
DAC	Digital-to-Analog Converter
Diff	Differential
DMix	Digital Mixing
DSP	Digital Sound Processor
DVol	Digital Volume
EQ	Equalizer
f_0	Center Frequency
f_c	Cut-off Frequency
FL	Front Lch
FR	Front Rch
f_s	Sampling Frequency
GND ISO	Ground Isolation
HPF	High-Pass Filter
I/O	Input/Output
I ² S	Inter-IC Sound bus
IC	Integrated Circuit
IIR	Infinite Impulse Response
LPF	Low-Pass Filter
LSB	Least Significant Bit
MSB	Most Significant Bit
Noise Gen	Noise Generator
P ² Bass	Perfect Pure Bass(ROHM original Bass Boost)
PLL	Phase-Locked Loop
RL	Rear Lch
RMS	Root Mean Square
RR	Rear Rch
SL	Sub Lch
S/N	Signal to Noise Ratio
S/PDIF	Sony/Philips Digital Interface
SpeAna	Spectrum Analyzer
SPI	Serial Peripheral Interface
SR	Sub Rch
SRC	Sampling Rate Converter
THD+N	Total Harmonic Distortion + Noise
X'over	Cross Over
X'tal	Crystal

Ordering Information

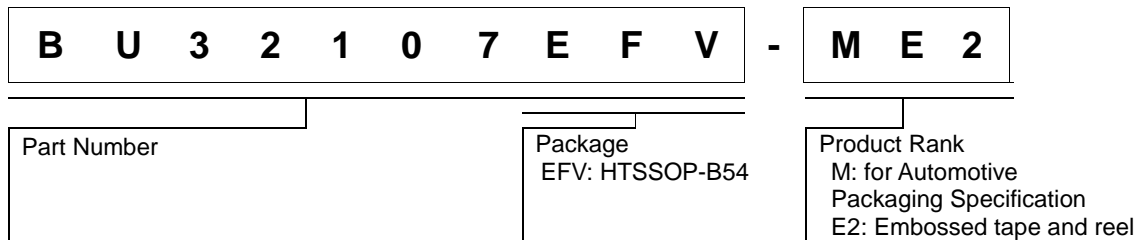

Marking Diagram

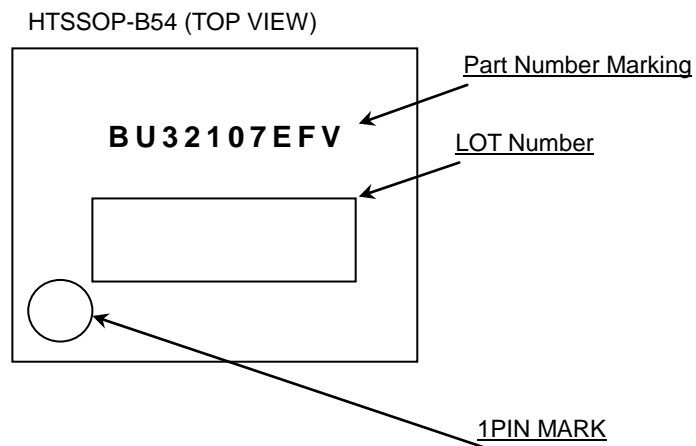
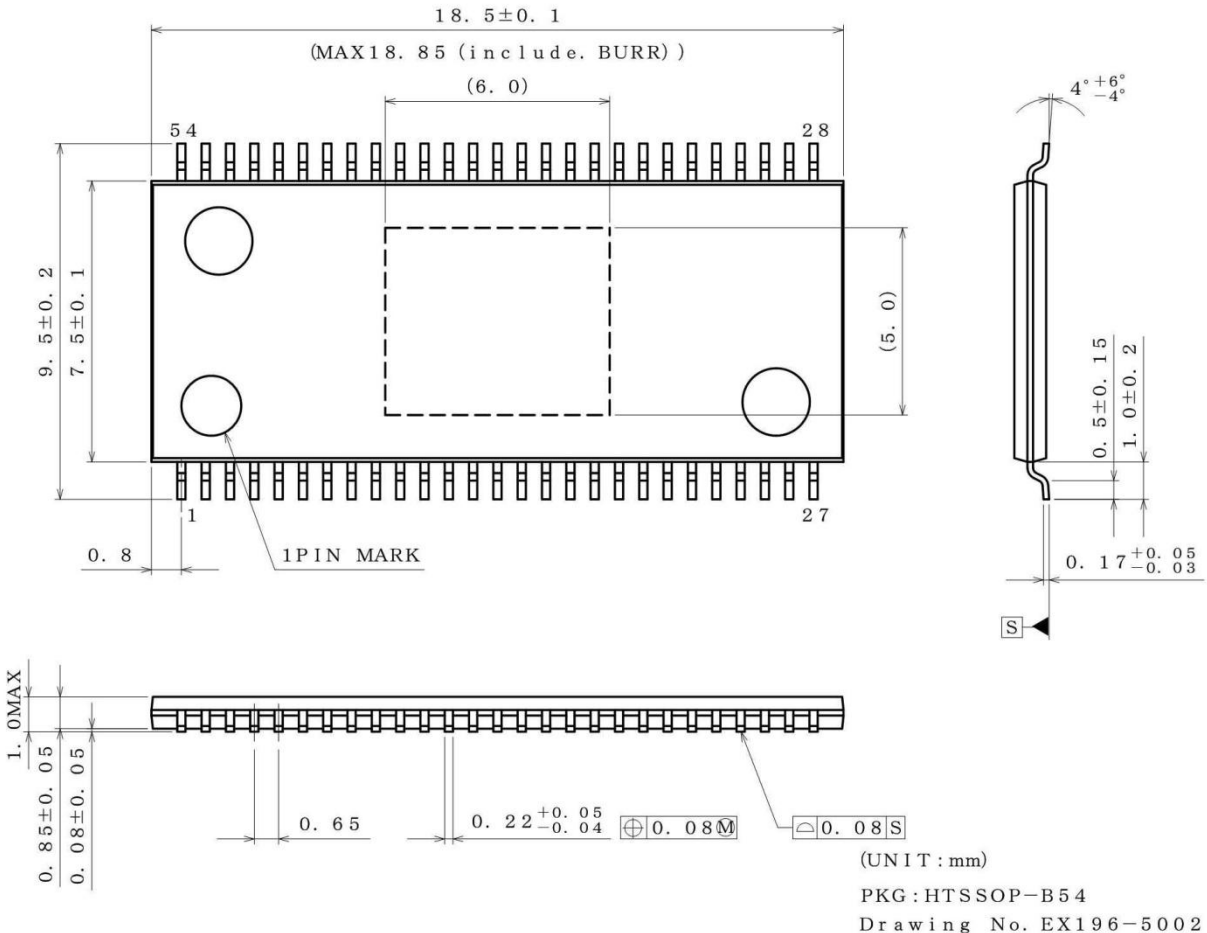

Figure 105. HTSSOP-B54

Physical Dimension Tape and Reel Information

Package Name	HTSSOP-B54
--------------	------------



<Tape and Reel information>

Tape	Embossed carrier tape (with dry pack)
Quantity	1500pcs
Direction of feed	E2 (The direction is the 1pin of product is at the upper left when you hold reel on the left hand and you pull out the tape on the right hand)

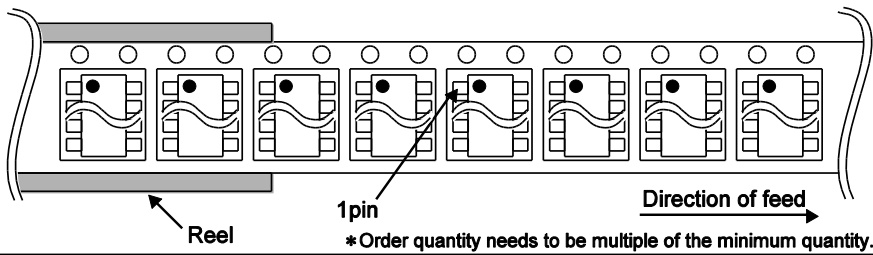

Revision History

Date	Revision	Changes
07.Apr.2017	001	New Release

Notice

Precaution on using ROHM Products

1. If you intend to use our Products in devices requiring extremely high reliability (such as medical equipment ^(Note 1), aircraft/spacecraft, nuclear power controllers, etc.) and whose malfunction or failure may cause loss of human life, bodily injury or serious damage to property ("Specific Applications"), please consult with the ROHM sales representative in advance. Unless otherwise agreed in writing by ROHM in advance, ROHM shall not be in any way responsible or liable for any damages, expenses or losses incurred by you or third parties arising from the use of any ROHM's Products for Specific Applications.

(Note1) Medical Equipment Classification of the Specific Applications

JAPAN	USA	EU	CHINA
CLASS III	CLASS III	CLASS II b	CLASS III
CLASS IV		CLASS III	

2. ROHM designs and manufactures its Products subject to strict quality control system. However, semiconductor products can fail or malfunction at a certain rate. Please be sure to implement, at your own responsibilities, adequate safety measures including but not limited to fail-safe design against the physical injury, damage to any property, which a failure or malfunction of our Products may cause. The following are examples of safety measures:
 - [a] Installation of protection circuits or other protective devices to improve system safety
 - [b] Installation of redundant circuits to reduce the impact of single or multiple circuit failure
3. Our Products are not designed under any special or extraordinary environments or conditions, as exemplified below. Accordingly, ROHM shall not be in any way responsible or liable for any damages, expenses or losses arising from the use of any ROHM's Products under any special or extraordinary environments or conditions. If you intend to use our Products under any special or extraordinary environments or conditions (as exemplified below), your independent verification and confirmation of product performance, reliability, etc. prior to use, must be necessary:
 - [a] Use of our Products in any types of liquid, including water, oils, chemicals, and organic solvents
 - [b] Use of our Products outdoors or in places where the Products are exposed to direct sunlight or dust
 - [c] Use of our Products in places where the Products are exposed to sea wind or corrosive gases, including Cl₂, H₂S, NH₃, SO₂, and NO₂
 - [d] Use of our Products in places where the Products are exposed to static electricity or electromagnetic waves
 - [e] Use of our Products in proximity to heat-producing components, plastic cords, or other flammable items
 - [f] Sealing or coating our Products with resin or other coating materials
 - [g] Use of our Products without cleaning residue of flux (even if you use no-clean type fluxes, cleaning residue of flux is recommended); or Washing our Products by using water or water-soluble cleaning agents for cleaning residue after soldering
 - [h] Use of the Products in places subject to dew condensation
4. The Products are not subject to radiation-proof design.
5. Please verify and confirm characteristics of the final or mounted products in using the Products.
6. In particular, if a transient load (a large amount of load applied in a short period of time, such as pulse. is applied, confirmation of performance characteristics after on-board mounting is strongly recommended. Avoid applying power exceeding normal rated power; exceeding the power rating under steady-state loading condition may negatively affect product performance and reliability.
7. De-rate Power Dissipation depending on ambient temperature. When used in sealed area, confirm that it is the use in the range that does not exceed the maximum junction temperature.
8. Confirm that operation temperature is within the specified range described in the product specification.
9. ROHM shall not be in any way responsible or liable for failure induced under deviant condition from what is defined in this document.

Precaution for Mounting / Circuit board design

1. When a highly active halogenous (chlorine, bromine, etc.) flux is used, the residue of flux may negatively affect product performance and reliability.
2. In principle, the reflow soldering method must be used on a surface-mount products, the flow soldering method must be used on a through hole mount products. If the flow soldering method is preferred on a surface-mount products, please consult with the ROHM representative in advance.

For details, please refer to ROHM Mounting specification

Precautions Regarding Application Examples and External Circuits

1. If change is made to the constant of an external circuit, please allow a sufficient margin considering variations of the characteristics of the Products and external components, including transient characteristics, as well as static characteristics.
2. You agree that application notes, reference designs, and associated data and information contained in this document are presented only as guidance for Products use. Therefore, in case you use such information, you are solely responsible for it and you must exercise your own independent verification and judgment in the use of such information contained in this document. ROHM shall not be in any way responsible or liable for any damages, expenses or losses incurred by you or third parties arising from the use of such information.

Precaution for Electrostatic

This Product is electrostatic sensitive product, which may be damaged due to electrostatic discharge. Please take proper caution in your manufacturing process and storage so that voltage exceeding the Products maximum rating will not be applied to Products. Please take special care under dry condition (e.g. Grounding of human body / equipment / solder iron, isolation from charged objects, setting of Ionizer, friction prevention and temperature / humidity control).

Precaution for Storage / Transportation

1. Product performance and soldered connections may deteriorate if the Products are stored in the places where:
 - [a] the Products are exposed to sea winds or corrosive gases, including Cl₂, H₂S, NH₃, SO₂, and NO₂
 - [b] the temperature or humidity exceeds those recommended by ROHM
 - [c] the Products are exposed to direct sunshine or condensation
 - [d] the Products are exposed to high Electrostatic
2. Even under ROHM recommended storage condition, solderability of products out of recommended storage time period may be degraded. It is strongly recommended to confirm solderability before using Products of which storage time is exceeding the recommended storage time period.
3. Store / transport cartons in the correct direction, which is indicated on a carton with a symbol. Otherwise bent leads may occur due to excessive stress applied when dropping of a carton.
4. Use Products within the specified time after opening a humidity barrier bag. Baking is required before using Products of which storage time is exceeding the recommended storage time period.

Precaution for Product Label

A two-dimensional barcode printed on ROHM Products label is for ROHM's internal use only.

Precaution for Disposition

When disposing Products please dispose them properly using an authorized industry waste company.

Precaution for Foreign Exchange and Foreign Trade act

Since concerned goods might be fallen under listed items of export control prescribed by Foreign exchange and Foreign trade act, please consult with ROHM in case of export.

Precaution Regarding Intellectual Property Rights

1. All information and data including but not limited to application example contained in this document is for reference only. ROHM does not warrant that foregoing information or data will not infringe any intellectual property rights or any other rights of any third party regarding such information or data.
2. ROHM shall not have any obligations where the claims, actions or demands arising from the combination of the Products with other articles such as components, circuits, systems or external equipment (including software).
3. No license, expressly or implied, is granted hereby under any intellectual property rights or other rights of ROHM or any third parties with respect to the Products or the information contained in this document. Provided, however, that ROHM will not assert its intellectual property rights or other rights against you or your customers to the extent necessary to manufacture or sell products containing the Products, subject to the terms and conditions herein.

Other Precaution

1. This document may not be reprinted or reproduced, in whole or in part, without prior written consent of ROHM.
2. The Products may not be disassembled, converted, modified, reproduced or otherwise changed without prior written consent of ROHM.
3. In no event shall you use in any way whatsoever the Products and the related technical information contained in the Products or this document for any military purposes, including but not limited to, the development of mass-destruction weapons.
4. The proper names of companies or products described in this document are trademarks or registered trademarks of ROHM, its affiliated companies or third parties.