

# kHz Range Crystal Devices Clock Oscillators Surface Mount Type KC3215A Series



CMOS/ 3.3V Typ./ 3.2×1.5mm



RoHS Compliant

## Features

- Output frequency: 32.768kHz
- Miniature and Low profile ceramic package
- Low current consumption: 0.35mA Typ (3.3V, Disable)
- Wide operating voltage range 1.5V to 3.6V
- CMOS output
- Operating Temp. -40 to +105°C (option)
- AEC-Q200 qualified

## Applications

- W-LAN etc.

## How to Order

KC3215A 32768 C 33 A A E 00  
① ② ③ ④ ⑤ ⑥ ⑦ ⑧

① Series	⑥ Freq. Temp. Chrst.
② Output Frequency	<b>A</b> +10/-120×10 <sup>-6</sup>
③ Output type	⑦ Output Waveform Symmetric
④ Supply Voltage	<b>E</b> 45 to 55%
<b>33</b> 3.3V	⑧ Customer Special Model Suffix
⑤ Frequency Tolerance	<b>00</b> STD Specification
<b>A</b> 5±23×10 <sup>-6</sup>	

Packaging (Tape & Reel 3000 pcs./ reel)

## Specifications

Item	Symbol	Conditions	Specifications			Units
			Min.	Typ.	Max.	
Output Frequency Range	fo	Standard Frequency	—	32.768	—	kHz
Frequency Tolerance	fo	after 2times Reflow, V <sub>CC</sub> = 3.3V, Ta = 25±2°C	-18	+5	+28	×10 <sup>-6</sup>
Frequency Temperature Characteristics	fo-Tc	Ta = -20 to +70°C (+25°C is reference)	-120	—	+10	×10 <sup>-6</sup>
Frequency Voltage Coefficient	fo-V	Ta = +25±2°C	-2.0	—	2.0	×10 <sup>-6</sup> /V
Frequency Aging	F <sub>age</sub>	Per Year	-3.0	—	3.0	×10 <sup>-6</sup>
Storage Temperature	T <sub>stg</sub>		-55	—	+125	°C
Operating Temperature	T <sub>use</sub>		-40	—	+85	°C
Supply Voltage	V <sub>DD</sub>		1.5	—	3.6	V
Interface Power Supply Voltage	V <sub>IO</sub>		1.5	—	3.6	V
Current Consumption	I <sub>CC</sub>	No load, V <sub>DD</sub> = 3.3V, V <sub>IO</sub> = 3.3V	—	0.9	1.5	μA
		load: 15pF, V <sub>DD</sub> = 3.3V, V <sub>IO</sub> = 3.3V	—	2.2	4.2	μA
Symmetry	SYM	@50% V <sub>IO</sub>	45	—	55	%
Rise/ Fall Time	tr/ tf	load: 15pF, 20%V <sub>IO</sub> to 80%V <sub>IO</sub>	—	—	50	ns
Low Output Voltage	V <sub>OL</sub>	I <sub>OL</sub> = +0.4mA	—	—	0.4	V
High Output Voltage	V <sub>OH</sub>	I <sub>OH</sub> = -0.4mA	V <sub>IO</sub> -0.4	—	—	V
CMOS Load	L <sub>CMOS</sub>	CMOS Output	—	—	15	pF
Disable Delay Time	t <sub>dis</sub>		—	—	1.0	μs
Start-up Time	t <sub>str</sub>	Time at minimum Supply voltage to be 0 s	—	—	0.6	sec

\* Unless otherwise stated, characteristics(specifications) shown in the above table are based on the rated operating temperature and voltage condition.

\* Please contact us for other specifications.

## Dimensions

(Unit: mm)

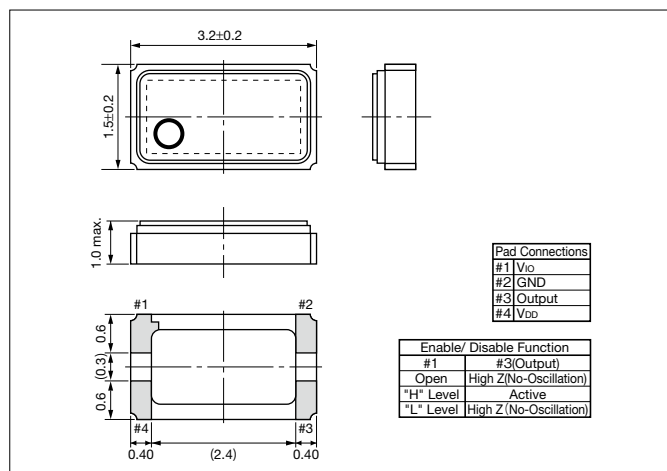

## Recommended Land Pattern

(Unit: mm)

