

OX-205 at 100 MHz

Ultra Low Phase Noise
Oven Controlled Crystal Oscillator

Helping Customers Innovate, Improve & Grow



The OX-205 is an Ultra Low Phase Noise Ovenized Crystal Oscillator with a noise floor as low as -176 dBc/Hz in a compact 1" x 1" enclosure. Designed for applications that demand extremely low noise sources, including the reference oscillator for a phase-locked loop in the microwave spectrum. Custom frequencies available upon request.

Features

- -135 dBc/Hz at 100 Hz offset
- -176 dBc/Hz at 100 kHz offset
- 100 MHz standard, other frequencies available
- Compact 1" x 1" hermetic enclosure

Applications

- Military Radar
- Instrumentation and Test Equipment
- Synthesizers
- Military Communication Equipment
- DRO reference
- Satellite Communications

Performance Specifications

Phase Noise Ordering Codes at 100 MHz					
Frequency Offset (Hz)	A	B	C	Unit	Condition
10	-100	-102	-105	dBc/Hz	Maximum values All EFC settings Static Environment
100	-130	-132	-135	dBc/Hz	
1000	-150	-156	-159	dBc/Hz	
10,000	-165	-168	-170	dBc/Hz	
100,000	-175	-175	-176	dBc/Hz	
Frequency Stabilities at 100 MHz					
Parameter	Min	Typical	Max	Unit	Condition
vs. operating temperature range	-100		+100	ppb	-20 to +70°C (referenced to +25°C)
	-200		+200	ppb	-40 to +85°C (referenced to +25°C)
Allan Deviation			1	E-11	0.1 to 1 second tau
vs. supply voltage change	-10		+10	ppb	±5% change
vs. load change	-10		+10	ppb	5% change in load
vs. aging / 1 day	-5		+5	ppb	after 30 days of operation
vs. aging / 1 st year	-200		+200	ppb	after 30 days of operation
vs. aging / 10 year	-1.5		+1.5	ppm	after 30 days of operation
Warm up time			5	minutes	to ±100 ppb of 2-hour frequency @+25°C

Performance Specifications

Supply Voltage (Vs)					
Parameter	Min	Typical	Max	Unit	Condition
Supply Voltage	11.4	12.0	12.6	VDC	
Power Consumption			4.5 1.8	Watts Watts	during warm-up steady state @ +25°C
Reference Voltage	9.8	10	10.2	VDC	
RF Output					
Signal	Sinewave				
Load		50		Ohms	
Output Power	+9.0		+13.0	dBm	50 Ohm load
Harmonics			-30	dBc	50 Ohm load
Spurious			-80	dBc	50 Ohm load
Frequency Tuning (EFC)					
Tuning Range	±1.5		±3.0	ppm	
Linearity			20	%	
Tuning Slope	Positive				
Control Voltage Range	0		10	VDC	
Input Impedance		20		kOhm	
Modulation Bandwidth	150			Hz	
Additional Parameters					
g- Sensitivity			1	ppb/g	worst axis
Weight			20	grams	
Absolute Maximum Ratings					
Parameter	Min	Typical	Max	Unit	Condition
Supply Voltage (Vs)			15	V	
Output Load			25	Ohms	
Operable Temperature Range	-55		+95	°C	Device will not sustain damage when operated at temperatures between the operating range and the operable range, but will not be specification compliant.
Environmental and Product Classification					
Shock (Endurance)	MIL-STD-202, Method 213, Condition J, 30 g 11 ms				
Sine Vibration (Endurance)	MIL-STD-202, Method 201 and 204, Condition A, except 5 g to 500 Hz, 1 sweep each axis				
Random Vibration (Endurance)	MIL-STD-202, Method 214, Condition I-D				
Humidity	MIL-STD-202, Method 103, Condition B, 100% rh				
Seal	MIL-STD-202, Method 112, Condition D				
Altitude	MIL-STD-202, Method 105, sea level to 30,000 ft				
Resistance to Soldering Heat	MIL-STD-202, Method 210, Condition A,B,C				
Terminal Strength	MIL-STD-202, Method 11, Condition C (5 bends at 45°, 2 lbs)				
Moisture Sensitive Level	1				
RoHS	6 (fully compliant) - no pure tin options available upon request, the device will be assigned a customer part number , not orderable through ordering codes				
Storage Temperature Range	-55		+125	°C	

Outline Drawing

Dimensions in inches [mm]

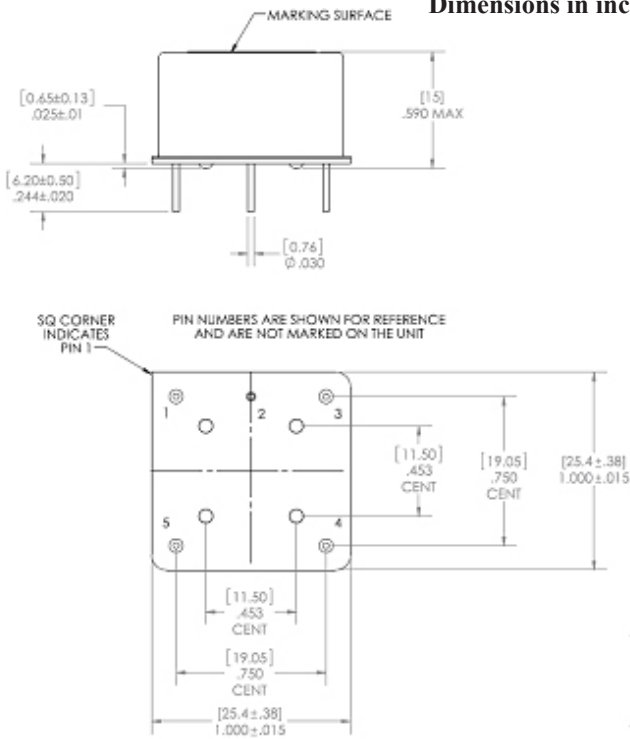

Code	Height "H"	Pin Length "L" Min
0	15.0	6.2
Pin Connections		
1	RF Output	
2	Ground (Case)	
3	Electronic Frequency Control Input (EFC)	
4	Reference Voltage	
5	Supply Voltage Input (VS)	

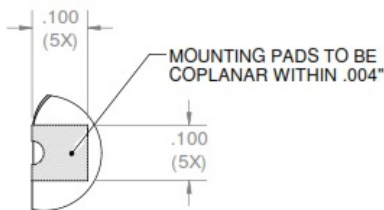

Dimensions in inches

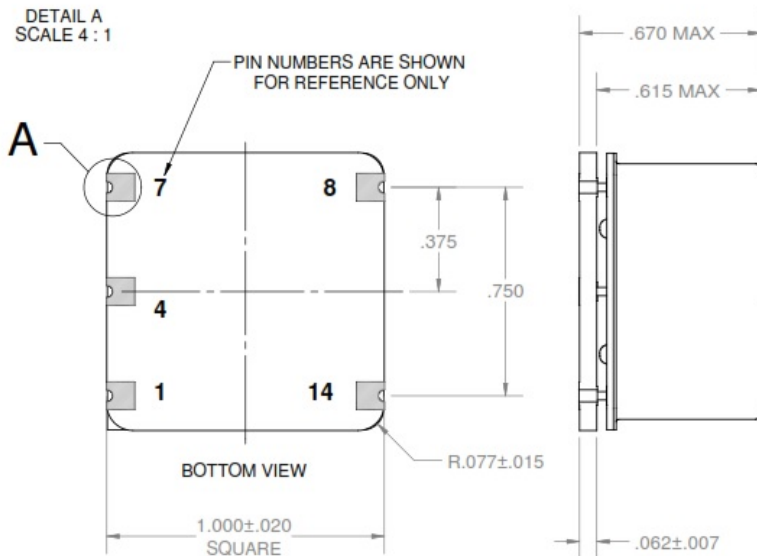

Code	Height "H"	Pin Length "L" Min
1	17.0 mm	na
Pin Connections		
1	RF Output	
4	Ground (Case)	
7	Electronic Frequency Control Input (EFC) No Connect for Fixed frequency Oscillators	
8	Reference Voltage	
14	Supply Voltage Input (VS)	

Ordering Information

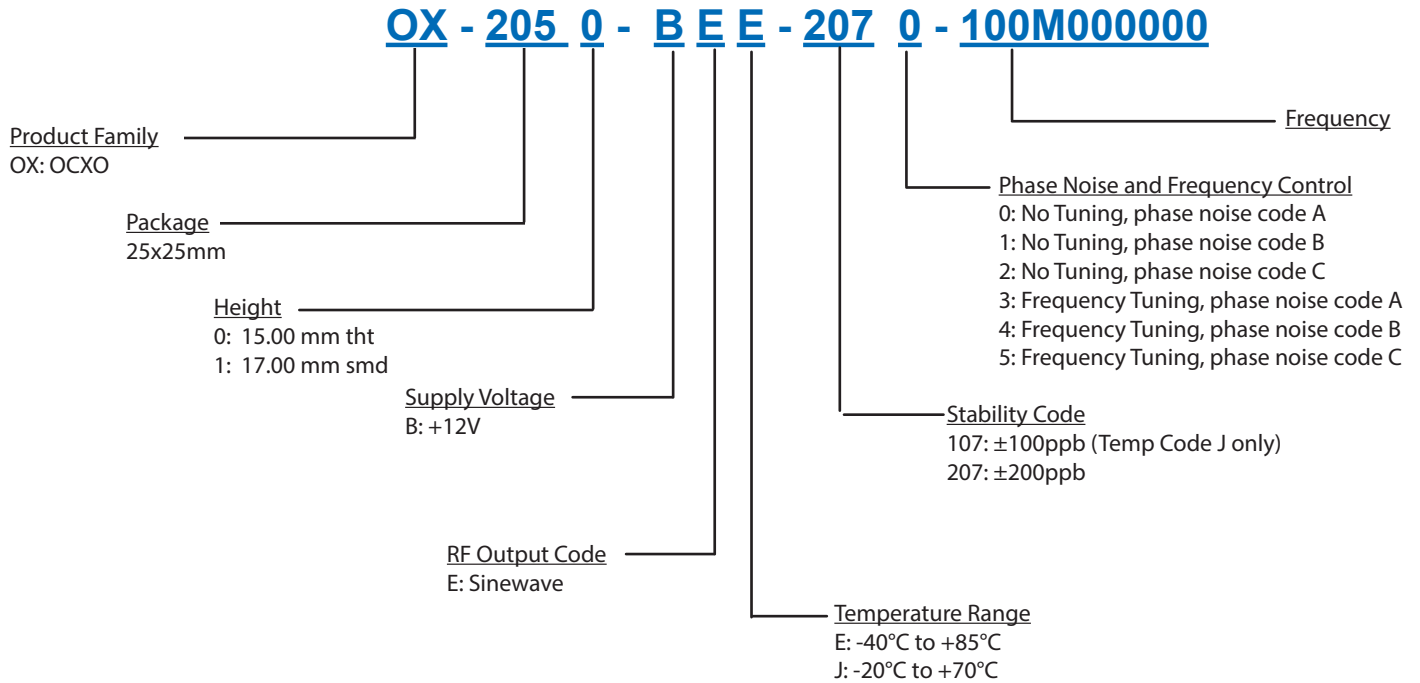

Notes:

1. Unless otherwise stated, all values are valid after warm-up time and refer to typical conditions for supply voltage, frequency control voltage, load, and temperature (25°C).
2. Contact factory for other frequencies. Phase noise degrades for frequencies greater than 100 MHz.
3. Subject to technical modification.
4. Contact factory for availability.

For Additional Information, Please Contact

USA:

Vectron International
267 Lowell Road, Unit 102
Hudson, NH 03051
Tel: 1.888.328.7661
Fax: 1.888.329.8328

Europe:

Vectron International
Landstrasse, D-74924
Neckarbischofsheim, Germany
Tel: +49 (0) 3328.4784.17
Fax: +49 (0) 3328.4784.30

Asia:

Vectron International
68 Yin Cheng Road(C), 22nd Floor
One LuJiaZui
Pudong, Shanghai 200120, China
Tel: +86 21 6194 6886
Fax: +86 21 6194 6699

Disclaimer

Vectron International reserves the right to make changes to the product(s) and or information contained herein without notice. No liability is assumed as a result of their use or application. No rights under any patent accompany the sale of any such product(s) or information.

Rev:11-21 2016 jar