



VS-401

Voltage Controlled SAW Oscillator High Frequency

Helping Customers Innovate, Improve & Grow



Description

The VS-401 VCSO (Voltage Controlled Saw Oscillator) from Vectron is a high frequency, ultra low phase noise oscillator designed to support high speed data converters and 100G coherent optical receivers. The VS-401 provides 12fs rms jitter in the 12kHz to 20MHz integration bandwidth and is available from 1.3GHz to 2.5GHz.

Features

- Frequency Range 1.3 to 2.5 GHz
- Ultra low jitter performance
- Typical Jitter: 12fsec rms, 12kHz to 20MHz
- 3.3 & 5V supply voltage
- Output sinewave + balanced sinewave
- 13x20 mm SMD package
- See table on Page 5 for standard frequencies

Applications

- High Speed ADCs
- 40G & 100G Coherent Receivers
- Test & Measurement

Performance Specifications

Pulling Characteristics					
Parameter	Min	Typ	Max	Units	Notes
Absolute Pull Range (APR)	±20			ppm	Includes df vs: •Operating temperature range +10 .. 85°C •Aging 10 years •Supply Voltage Change 5% •Load change 10%
Tuning Slope	Positive				
Control Voltage Range	0.5	2.5	4.5	V DC	with $V_s = 5V$
	0	1.65	3.3	VDC	with $V_s = 3.3V$
Frequency control input impedance	10			kΩ	
Supply Voltage (V_s)					
Supply voltage (standard)	4.75	5.00	5.25	V DC	
Current consumption			75	mA	@ Sinewave / Balanced Sinewave
Supply voltage	3.135	3.3	3.465	VDC	
Current consumption			100	mA	@ Sinewave / Balanced Sinewave

Performance Specifications (Continued)

RF Output					
Parameter	Min	Typ	Max	Units	Notes
Signal	Sinewave				
Load	45	50	55	Ω	
Output Power	7	8.5	12	dBm	
Signal	Balanced Sinewave				
Load	45	50	55	Ω	
Output Power	0	3	6	dBm	
Phase difference between output signal pairs			± 10	$^{\circ}$	
Subharmonics			-30	dBc	
Phase Noise: 100Hz offset		-63		dBc/Hz	@ 1.75GHz Sinewave 5V
Phase Noise: 1kHz offset		-92		dBc/Hz	
Phase Noise: 10kHz offset		-119		dBc/Hz	
Phase Noise: 100kHz offset		-141		dBc/Hz	
Phase Noise: 1MHz offset		-155		dBc/Hz	
Phase Noise: 10MHz offset		-163		dBc/Hz	
Jitter: 12kHz to 20MHz offset		12		fs rms	
Phase Noise: 100Hz offset		-62		dBc/Hz	@ 1.98GHz Balanced Sinewave 5V
Phase Noise: 1kHz offset		-92		dBc/Hz	
Phase Noise: 10kHz offset		-118		dBc/Hz	
Phase Noise: 100kHz offset		-140		dBc/Hz	
Phase Noise: 1MHz offset		-155		dBc/Hz	
Phase Noise: 10MHz offset		-161		dBc/Hz	
Jitter: 12kHz to 20MHz offset		13		fs rms	
Phase Noise: 100Hz offset		-64		dBc/Hz	@ 2.46GHz Balanced Sinewave 3.3V
Phase Noise: 1kHz offset		-94		dBc/Hz	
Phase Noise: 10kHz offset		-118		dBc/Hz	
Phase Noise: 100kHz offset		-138		dBc/Hz	
Phase Noise: 1MHz offset		-151		dBc/Hz	
Phase Noise: 10MHz offset		-160		dBc/Hz	
Jitter: 12kHz to 20MHz offset		11		fs rms	

Additional Parameters

Weight	2.0g				
Processing and Packing	Handling and Processing Note				
Absolute Maximum Ratings					
Parameter	Min		Max	Units	Notes
Supply Voltage (V_s)			6.0	V	
Operable Temperature Range	-40		+85	$^{\circ}\text{C}$	
Storage Temperature Range	-40		+95	$^{\circ}\text{C}$	

Typical Performance

Phase Noise

VS-401 @ 1.75GHz Sinewave

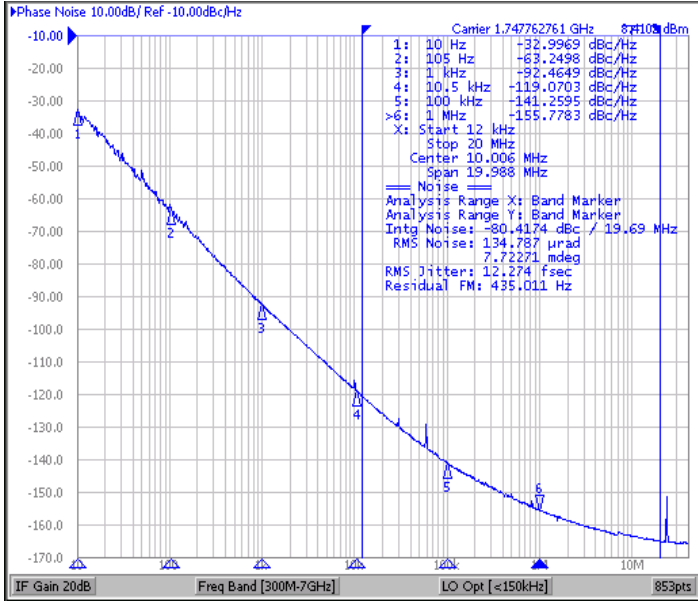

Phase Noise

VS-401 @ 1.97GHz Balanced Sinewave

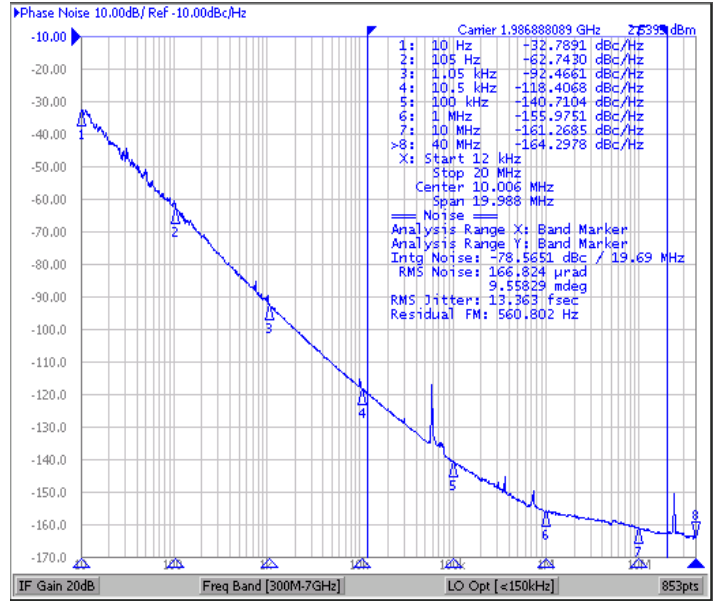

Phase Noise

VS-401 @ 2.46GHz Balanced Sinewave

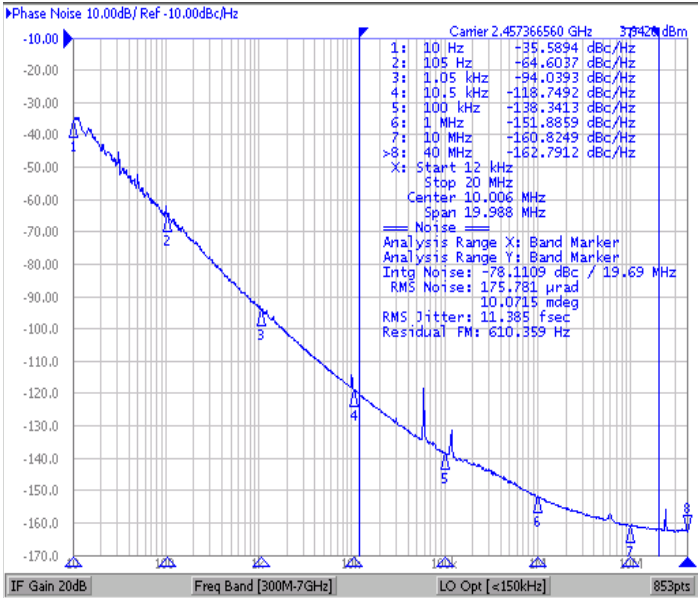

Outline Drawing / Enclosure

Package Codes		
Code	Height "H"	Pin Length "L"
G239	5.9	NA

Dimensions in mm

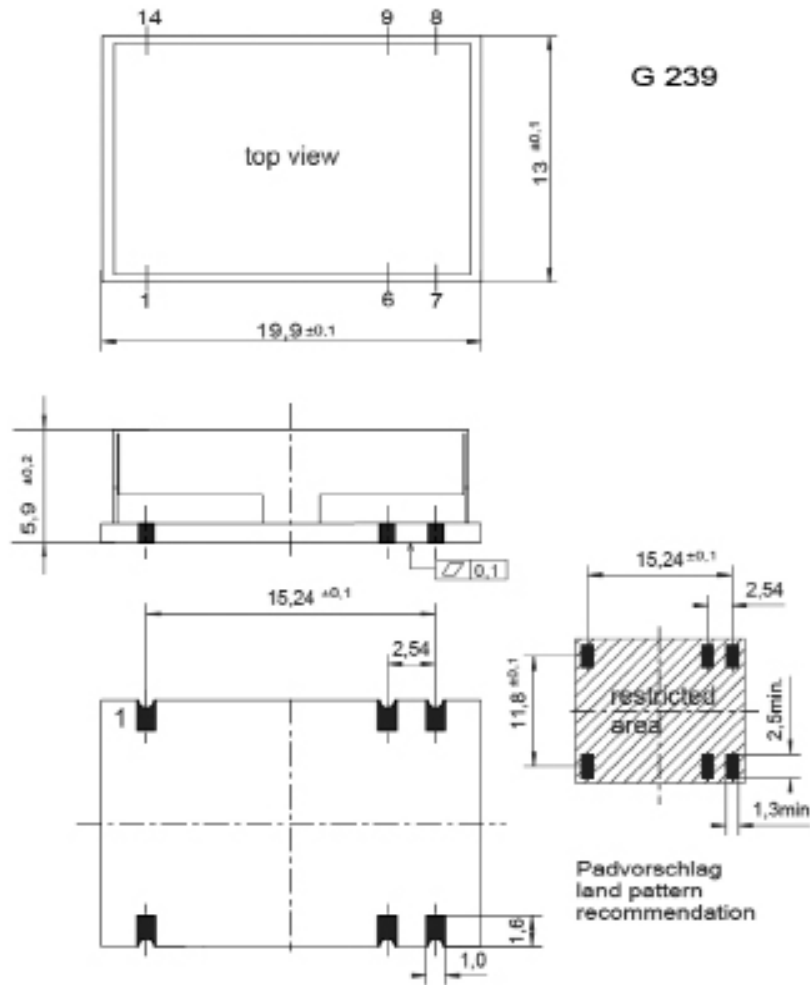

Pin Assignment (Sinewave)	
1	Control Voltage (V_C)
6	GND
7	GND
8	RF Out
9	GND
14	Supply Voltage Input (V_S)

Pin Assignment (Balanced Sinewave)	
1	Control Voltage (V_C)
6	GND
7	GND
8	RF Out
9	RF Out compl. (180° phase shifted)
14	Supply Voltage Input (V_S)

Marking	
VS-401-xxxx	
Frequency	
•AYYWW	

Standard Shipping Method

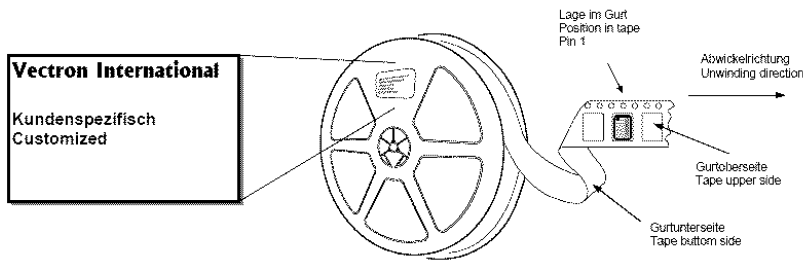
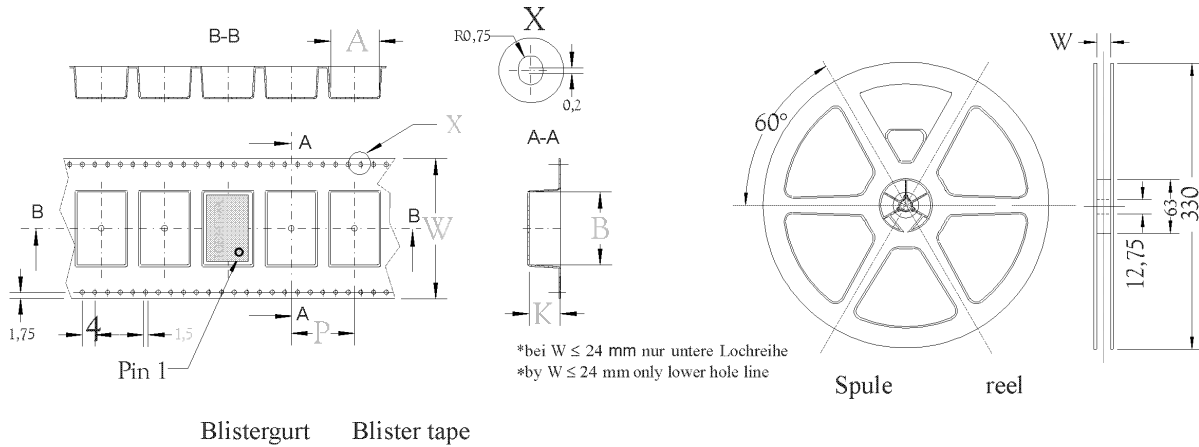

Enclosure Type	Tape Width W (mm)	Quantity per meter	Quantity per reel	Dimension P
G239	24		500	12

Recommended Reflow Profile

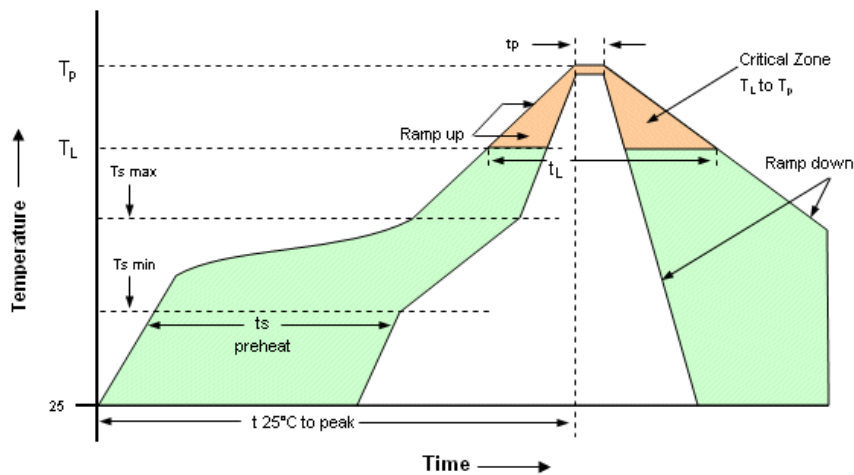

Profile Feature	Pb-Free Assembly/Sn-Pb Assembly	Profile Feature	Pb-Free Assembly/Sn-Pb Assembly
Average ramp-up rate (T_L to T_p)	3°C/second max.	Time 25°C to Peak Temperature	8 minutes max.
Preheat - Temperature Min T_{smin} -Temperature Min T_{sma} -Time (min to max) t_s	150°C 200°C 60-180 seconds	Time maintained above -Temperature (T_L) -Time (t_L)	217°C 60-150 seconds
T_{smax} to T_L -Ramp-up Rate	3°C/second max		
Time maintained above -Temperature (T_L) -Time (t_L)	217°C 60-150 seconds	Time within 5°C of actual Peak-Temperature (t_p)	20-40 seconds
Peak Temperature (T_p)	max 260°C	Ramp-down Rate	6°C/ second max

Note: All temperatures refer to topside of the package, measured on the package body surface. SMD oscillators must be on the top side of the PCB during the reflow process.

Ordering Information

VS - 401 0 - D E X - 205 X - 1747M03083

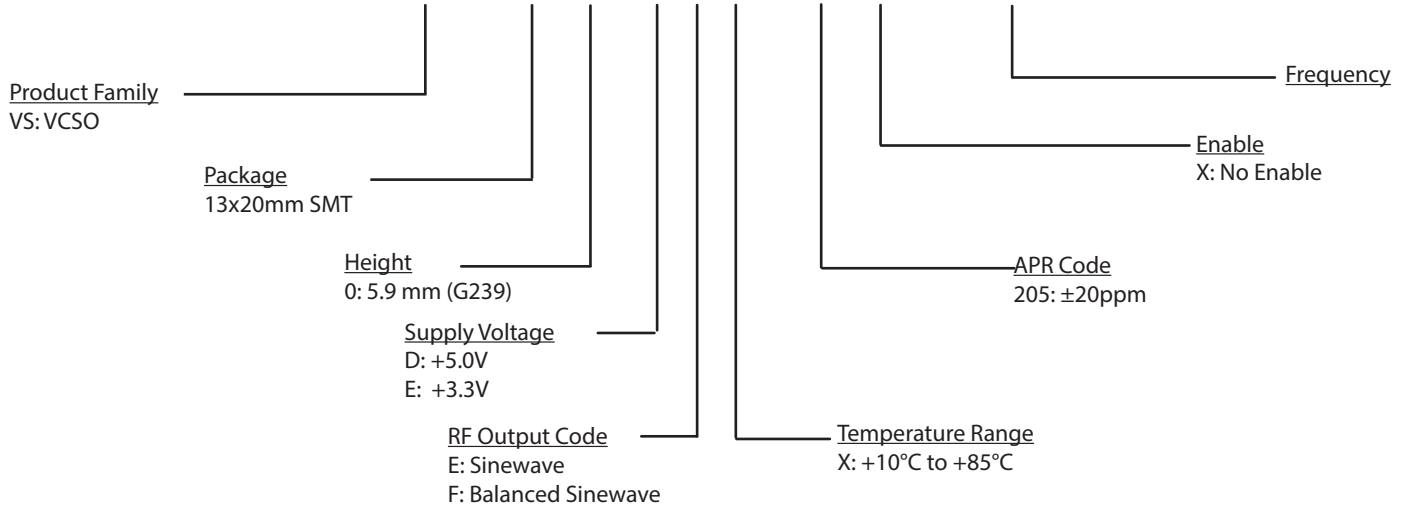

Standard Frequencies (MHz)						
1000	1040	1687.5	1701.32	1707.08	1747.030837	1747.62305
1748.366885	1769.145	1879.437686	1884.052863	1959.55	1968.75	1980.022
1986.819383	2000	2104.658326	2187.5	2457.6		

Other Frequencies Available Upon Request

Notes:

1. Contact factory for improved stabilities or additional product options. Not all options and codes are available at all frequencies.
2. Unless other stated all values are valid after warm-up time and refer to typical conditions for supply voltage, frequency control voltage, load, temperature (25°C).
3. Phase noise degrades with increasing output frequency.
4. Subject to technical modification.
5. Contact factory for availability.

For Additional Information, Please Contact

USA:

Vectron International
267 Lowell Road, Unit 102
Hudson, NH 03051
Tel: 1.888.328.7661
Fax: 1.888.329.8328

Europe:

Vectron International
Landstrasse, D-74924
Neckarbischofsheim, Germany
Tel: +49 (0) 3328.4784.17
Fax: +49 (0) 3328.4784.30

Asia:

Vectron International
68 Yin Cheng Road(C), 22nd Floor
One LuJiaZui
Pudong, Shanghai 200120, China
Tel: +86 21 6194 6886
Fax: +86 21 6194 6699

Disclaimer

Vectron International reserves the right to make changes to the product(s) and or information contained herein without notice. No liability is assumed as a result of their use or application. No rights under any patent accompany the sale of any such product(s) or information.

Rev: 3/2014