

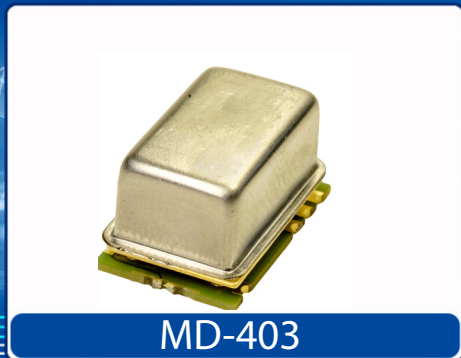

# MD-403

## I<sup>2</sup>C Interface Oven Controlled Crystal Oscillator

Helping Customers Innovate, Improve & Grow



MD-403

The MD-403 is a Vectron module that contains a medium size ovenized crystal oscillator and an I<sup>2</sup>C interface that communicates with an onboard EEPROM and temperature sensors. The interface enables the customer to improve upon the already exceptional stability of the oscillator. Provided in a fully hermetic 13 x 20 x 10.7mm package, the device is capable of aging rates of 1ppb/day and temperature stabilities of 10 ppb from -40 to 95°C. Use of the information provided in the I<sup>2</sup>C interface provides a cost effective means of improving stability by as much as a factor of 10 depending upon environmental conditions.

### Features

- Surface Mount package
- Low Profile Compact Package
- Standard frequency: 10, 20, 30.72, 38.88, 40 MHz
- Temperature stability to 10 ppb
- Temperature range: -40 to 95°C
- Aging rate to 1 ppb/day
- I<sup>2</sup>C interface with frequency coefficients, temperature sensor for additional correction

### Applications

- Base stations
- Test equipment
- Synthesizers
- Military communication equipment
- Digital Switching

### Performance Specifications

Frequency Stabilities <sup>1</sup> ( 10 -40 MHz)					
Parameter	Min	Typical	Max	Units	Condition
vs. operating temperature range (referenced to +25°C)	-10		+10	ppb	-20 to +70°C
	-10		+10	ppb	-40 to +85°C
	-10		+10	ppb	-40 to +95°C
Residual error compare to fit curve	-0.6		0.6	ppb	
Improved Frequency versus temperature F(T) performance obtained using on board temperature sensor (T) and frequency vs. temperature coefficients (An) stored in EEPROM, using formula: $F(T) = A_4 T^4 + A_3 T^3 + A_2 T^2 + A_1 T + A_0$					
Initial tolerance	-5		5	ppm	at time of shipment,
vs. supply voltage change	-10		+10	ppb	V <sub>s</sub> ±5% static
vs. load change	-10		+10	ppb	Load ±5% static
vs. aging / day	-1		+1	ppb	after 30 days of operation
vs. aging / year	-100		+100	ppb	after 30 days of operation
vs. aging / 10 year	-800		+800	ppb	after 30 days of operation
holdover (without compensation on customer side.)			2.5	µsec	over 30 minutes and 10°C temp jump @ T oscillator must be for minimum 7 days on power.
holdover (with compensation on customer side.) <sup>6</sup>			1		over 30 minutes and 10°C temp jump @ T oscillator must be for minimum 7 days on power.
Warm-up time			3	minutes	to ±100ppb of final frequency (1 hour reading) @ +25°C

## Performance Specifications

Supply Voltage (Vs)						
Parameter	Min	Typical	Max	Units	Condition	
Supply voltage (standard)	3.135	3.3	3.465	VDC		
Power consumption			2.5	Watts	during warm-up	
			1.0	Watts	steady state @ +25°C	
RF Output						
Signal [standard]	HCMOS					
Load		15		pF		
Signal Level (Vol)			0.4	VDC	with Vs=3.3V and 15pF Load	
Signal Level (Voh)	2.4			VDC	with Vs=3.3V and 15pF Load	
rise time			5	ns		
fall time			5	ns		
Duty Cycle	45		55	%	@ (Voh-Vol)/2	
Frequency Tuning (EFC)						
Tuning Range	Fixed OCXO; No adjust					
Additional Parameters						
Phase Noise <sup>3</sup>		-85	-70	dBc/Hz	1 Hz	@ 20MHz
		-110	-95	dBc/Hz	10 Hz	
		-130	-115	dBc/Hz	100 Hz	
		-143	-135	dBc/Hz	1 kHz	
		-150	-145	dBc/Hz	10 kHz	
		-153	-150	dBc/Hz	100kHz	
Phase Noise <sup>3</sup>		-76	-60	dBc/Hz	1 Hz	@ 30.72 Mhz
		-105	-90	dBc/Hz	10 Hz	
		-130	-115	dBc/Hz	100 Hz	
		-145	-130	dBc/Hz	1 kHz	
		-150	-145	dBc/Hz	10 kHz	
		-155	-150	dBc/Hz	10 kHz	
Weight			10	g		
Processing & Packing	Handling & Processing Note					
EEPROM (SCL, SDA) Pin 12; Pin 13						
Parameter	Min	Typical	Max	Units	Condition	
I2C Bus Voltage		2,8		VDC		
DC Electrical Characteristics						
High Level Input Voltage (Vih)	0.7*VI2C		VI2C +0.3	Vdc	SDA (internally pulled-up to V <sub>I2C</sub> with a 22kohm resistor) and SCL	
Low Level Input Voltage (Vil)	-0.3		0.3 VI2C	Vdc	SDA (internally pulled-up to V <sub>I2C</sub> with a 22kohm resistor) and SCL	
Electrical Characteristic	Product is to communicate via industry standard I <sup>2</sup> C bus timing. I <sup>2</sup> C is a Phillips Semiconductor registered trademark.					
SCL Clock Frequency	0		100	kHz		
Communication	Product is to communicate via industry standard I <sup>2</sup> C bus timing. I <sup>2</sup> C is a Phillips Semiconductor registered trademark.					
EEPROM	I2C Device 7-bit Address: 1010100					
Internal Temperature Sensor	I2C Device 7-bit Address: 1001000					
	model LM73					
For full EEPROM Map please contact factory						

Absolute Maximum Ratings					
supply voltage (Vs)			5.5	V	with Vs=3.3 & 5.0VDC
Output Load			50	pF	
Operable Temperature Range	-40		+95	°C	
Storage Temperature Range	-40		+125	°C	

## Outline Drawing / Enclosure

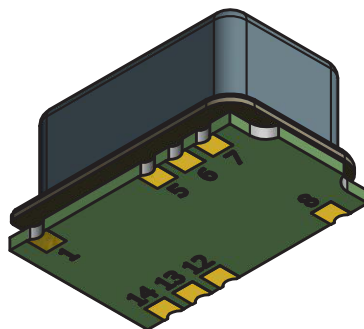
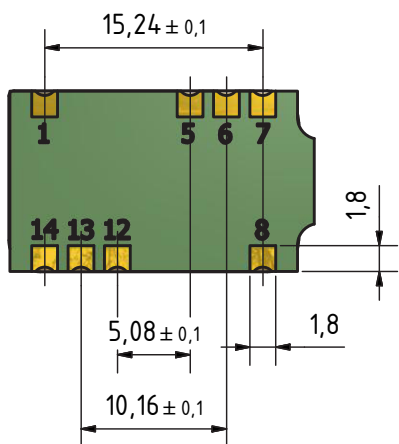

MD-403	
Height "H"	cover material
10,7 mm	metal

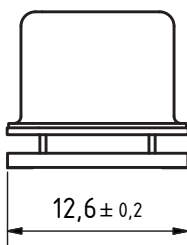
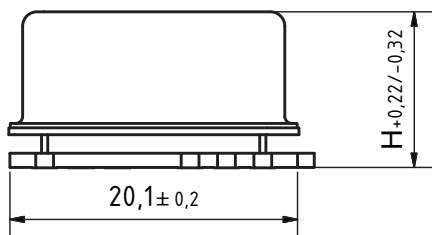

Pin Connections	
1	I.C (int. connected, do not connect)
5	WP (Write protect; I2C)
6	I.C (int. connected, do not connect)
7	Ground (Case)
8	RF Output
12	SDA (I2C)
13	SCL (I2C)
14	Supply Voltage Input (Vs)

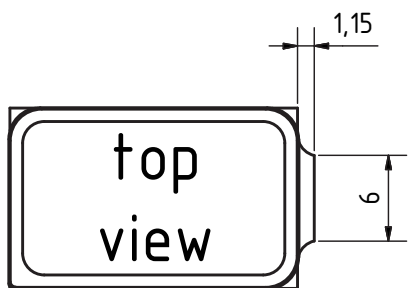

original size



recommended PCB Layout

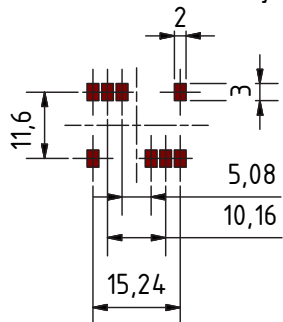

Dimensions in mm

## Standard Shipping Method (MD-403)

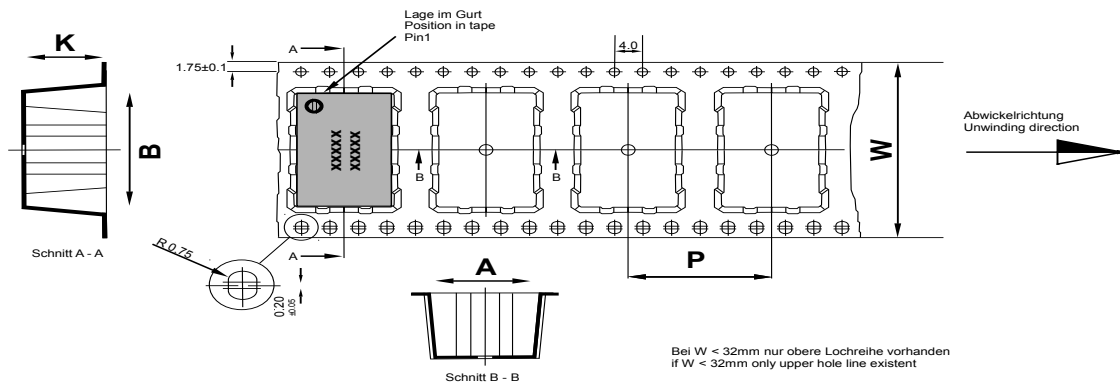

Maßangaben in mm: A, B und K Maße von Bauelement abhängig Fertigungstoleranzen entsprechen der DIN IEC 286-3	Dimension in mm: A, B und K are dependent upon component dimensions production tolerance complying DIN IEC 286-3
--	--

All dimensions in millimeters unless otherwise stated

Enclosure Type	Tape Width W (mm)	Quantity per meter	Quantity per reel	Dimension P
MD-403	44	50	230	20

## Recommended Reflow Profile

IPC/JEDEC J-STD-020 (latest revision)

Additional Information:

This SMD oscillator has been designed for pick and place reflow soldering.

SMD oscillators must be on the top side of the PCB during the reflow process.

## Additional Environmental Conditions

Parameter	Description
Rapid temperature changes	MIL-883-1010 Cond B 1000 cycles -55/125C
Vibration	MIL-STD-883 Meth 2007 Cond A 20G 20-2000Hz 4x in each 3axis 4 min
Shock	Mech.Shock MIL-STD-202 Meth 213 Cond.C 100G 6ms 6 shocks in each direction
Solderability	J_STD_002C Cond A, Through hole device/ Cond. B, SMD 255C (diving time 50,5sec.) Dip+Look with 8h damp pre-treatment: solder wetting >95%
Solvent resistance	MIL-STD-883 Meth 2015 Solv. 1,3,4
ESD	HBM JESD22-A114-F Class 1C 10* 1000V
Moisture Sensit.	Level 1 JESD22-A113-B
RoHS compliance	100% RoHS 6 compliant
Washable	washable device

**Note:** All temperatures refer to topside of the package, measured on the package body surface.

# typical performance data

## typical warm up

@ MD-4031-EAE-1080-30M72

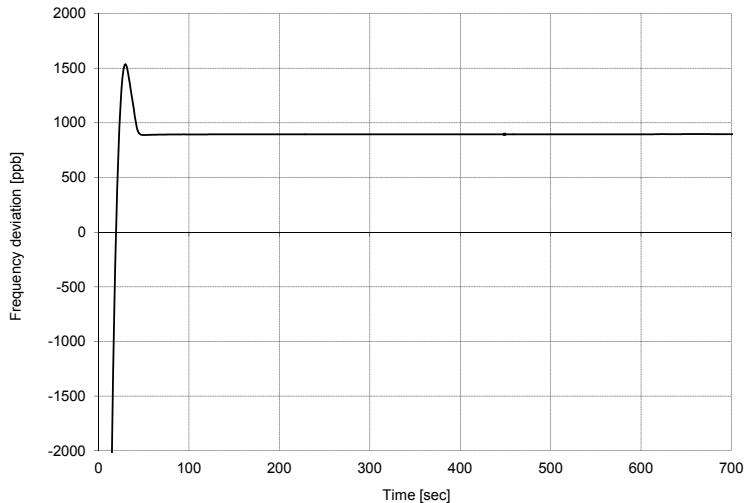

## typical temperature stability

@ MD-4031-EAE-1080-30M72

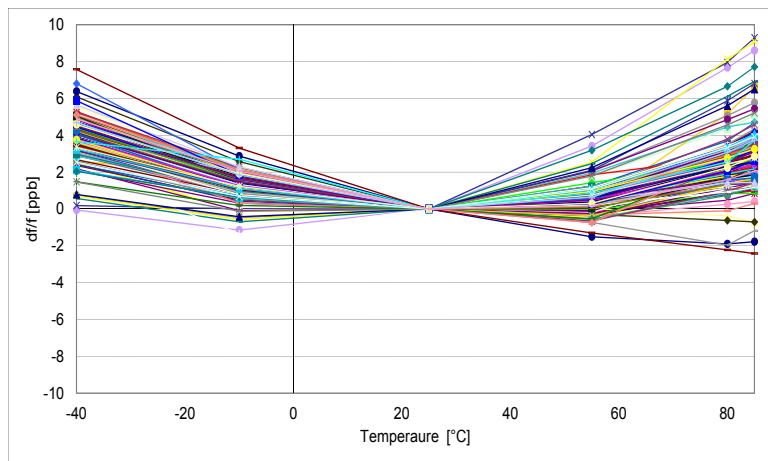

## typical Phase Noise

@ MD-4031-EAE-1080-30M72

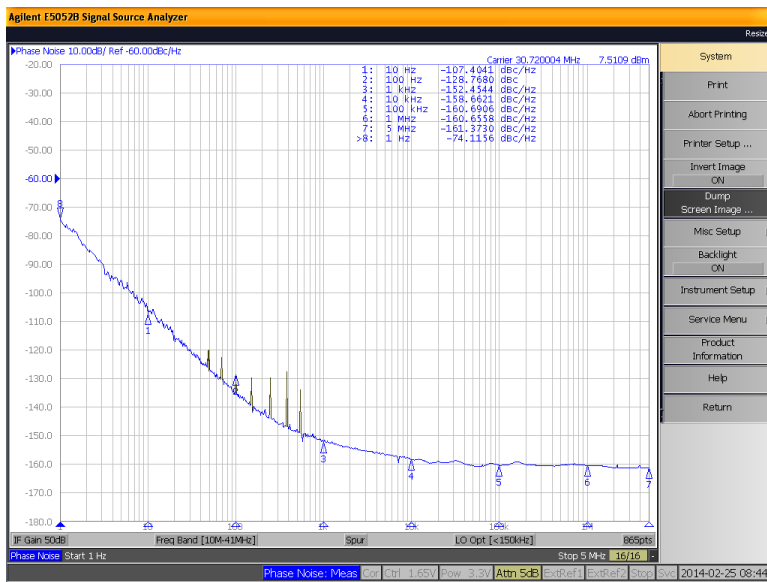

## typical residual error compare to fit curve

@ MD-4031-EAE-1080-30M72

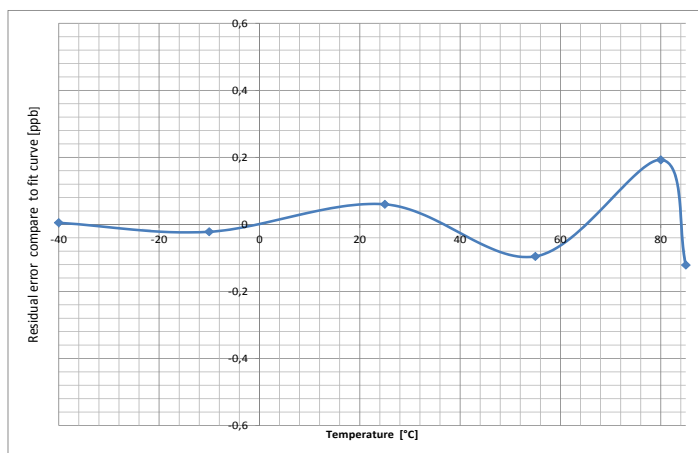

# typical performance data

## typical aging data

@ MD-4031-EAE-1080-30M72

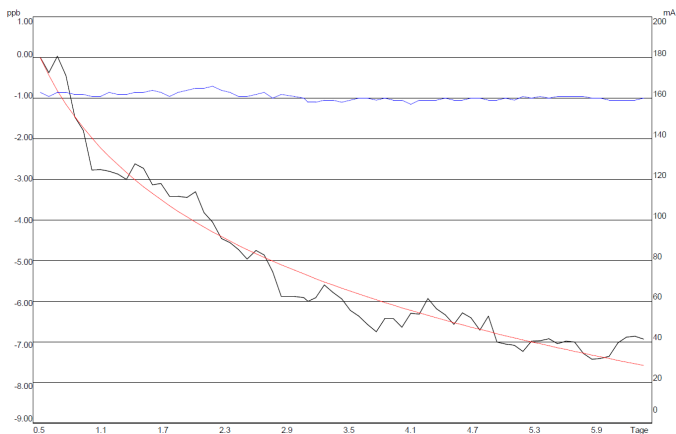

## typical frequency vs. supply voltage

@ MD-4031-EAE-1080-30M72

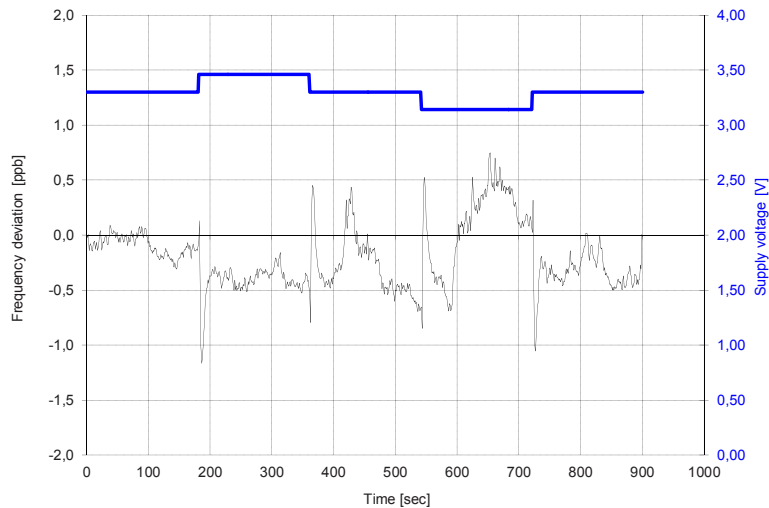

## typical ADEV

@ MD-4031-EAE-1080-30M72

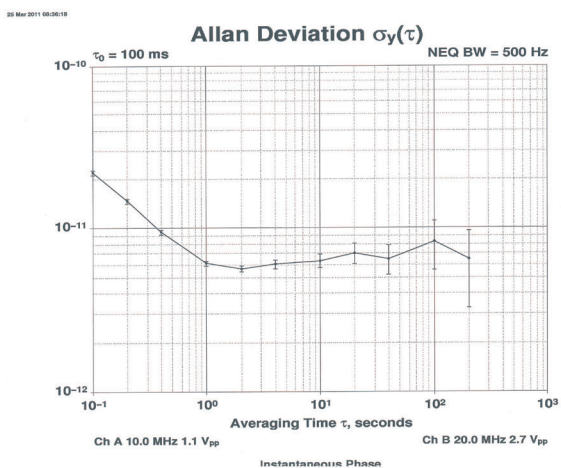

## typical retrace

@ MD-4031-EAE-1080-30M72

68 hours power on; 24 hours power off; 24 hours power on

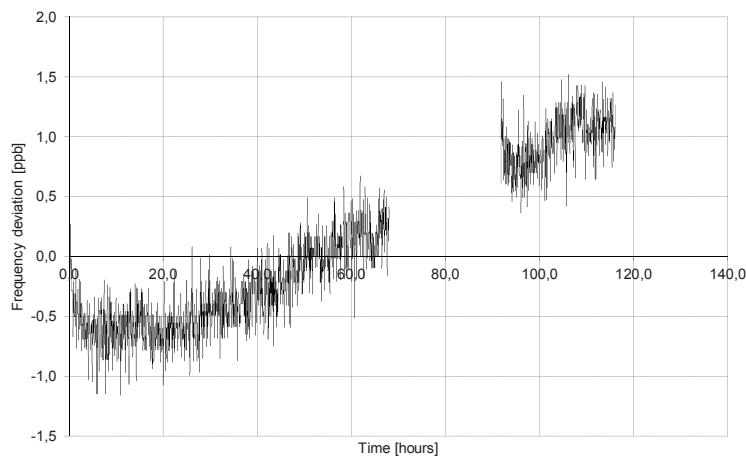

## typical performance data

### typical case temperature vs. outside temperature

@ MD-4031-EAE-1080-30M72

### typical power consumption vs. operating temperature

@ MD-4031-EAE-1080-30M72

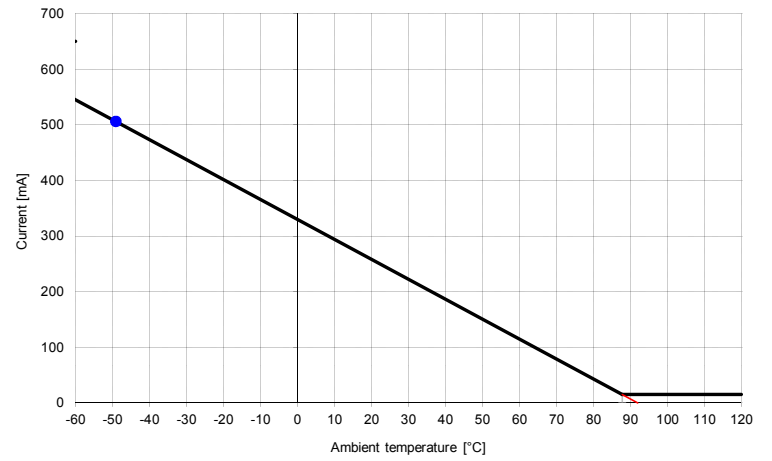
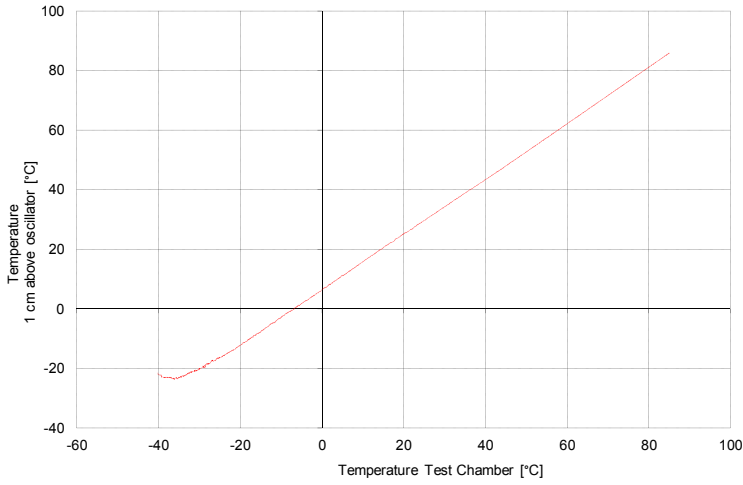

### recommended power on time after x days of power off

@ MD-4031-EAE-1080-30M72

@ MD-4031-EAE-1080-30M72

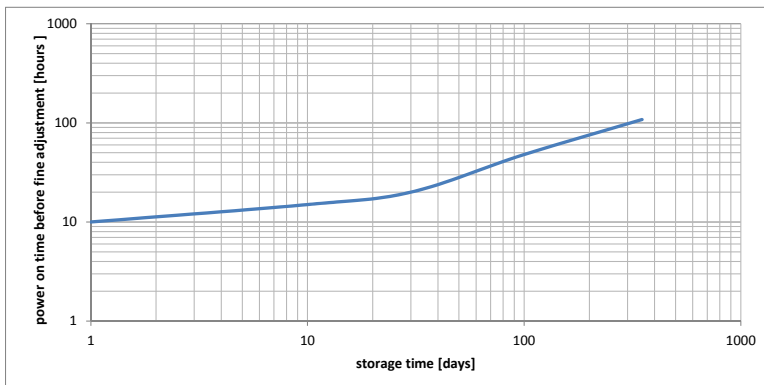



## Ordering Information

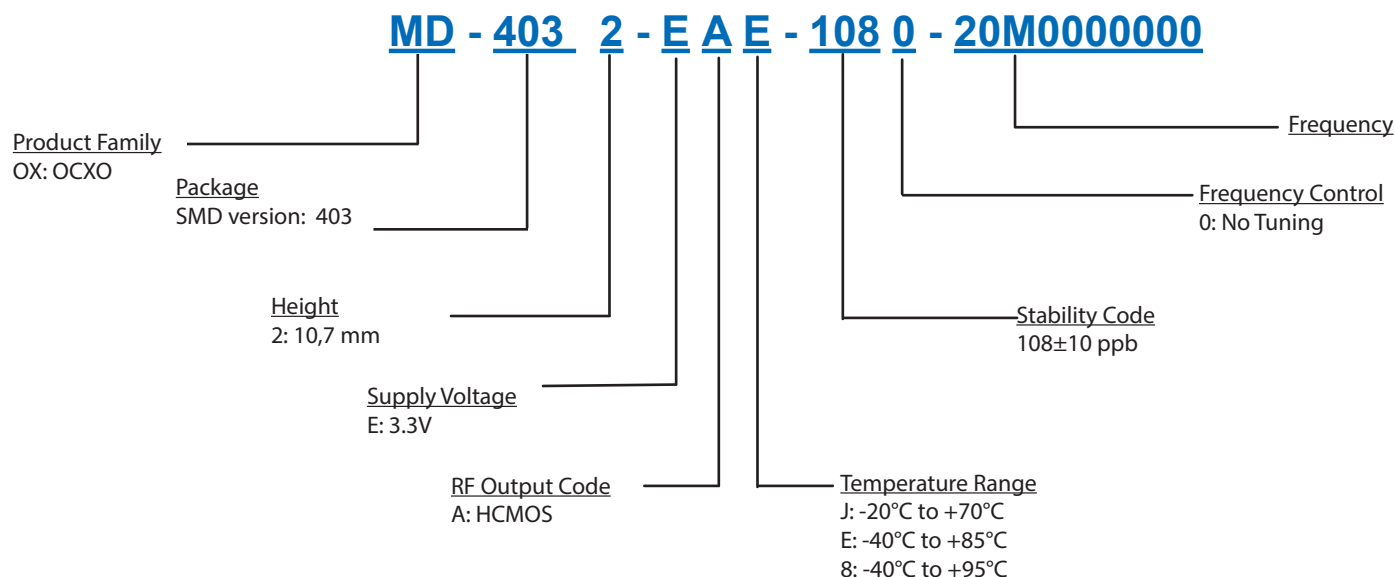

### Notes:

1. Contact factory for improved stabilities or additional product options. Not all options and codes are available at all frequencies.
2. Unless other stated all values are valid after warm-up time and refer to typical conditions for supply voltage, frequency control voltage, load, temperature (25°C).
3. Phase noise degrades with increasing output frequency.
4. Subject to technical modification.
5. Contact factory for availability.
6. final results depend on the compensation algorithm, position on the board, shielding against airflow and other

## For Additional Information, Please Contact

### USA:

Vectron International  
267 Lowell Road  
Suite 102  
Hudson, NH 03051  
Tel: 1.888.328.7661  
Fax: 1.888.329.8328

### Europe:

Vectron International  
Landstrasse, D-74924  
Neckarbischofsheim, Germany  
Tel: +49 (0) 7268.801.100  
Fax: +49 (0) 7268.801.282

### Asia:

Vectron International  
68 Yin Cheng Road(C), 22nd Floor  
One LuJiaZui  
Pudong, Shanghai 200120, China  
Tel: +86 21 6194 6886  
Fax: +86 21 6194 6699

### Disclaimer

Vectron International reserves the right to make changes to the product(s) and or information contained herein without notice. No liability is assumed as a result of their use or application. No rights under any patent accompany the sale of any such product(s) or information.

Rev: 16.01.2015