

3 CIRCUIT SHOWN

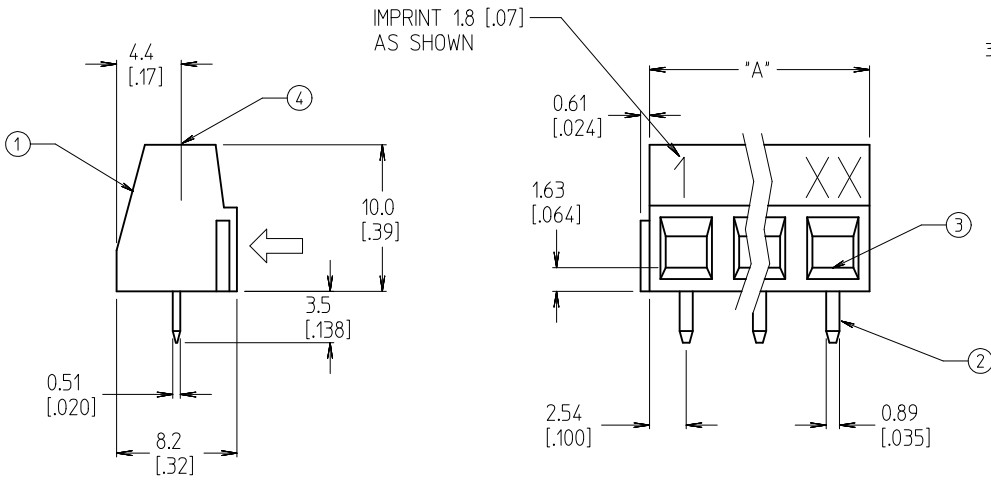

NOTES:

1. MATERIAL: SEE TABLE
2. FINISHES: SEE TABLE
3. ASSEMBLY IS ROHS COMPLIANT BY EXEMPTION. COMPONENTS MARKED WITH AN ASTERISK (*) ARE ROHS COMPLIANT BY EXEMPTION. ALL OTHERS ARE ROHS COMPLIANT.
4. INCH DIMS ARE SHOWN IN BRACKETS [XXX].

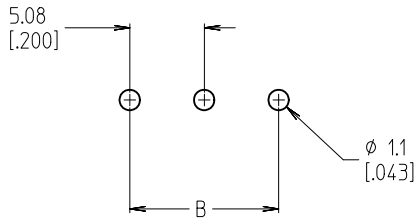

MATERIAL NO. 10A, GREEN	MATERIAL NO. 10A, BLACK	MATERIAL NO. (GREEN)	MATERIAL NO. (BLACK)	NO. OF CIRCUITS "XX"	DIM. "A"	DIM. "B"
	398820302	398804302	398800302	02	10.2 [.40]	5.08 [2.00]
	398820303	398804303	398800303	03	15.2 [.60]	10.16 [4.00]
	398820304	398804304	398800304	04	20.3 [.80]	15.24 [6.00]
		398804305	398800305	05	25.4 [1.00]	20.32 [8.00]
		398804306	398800306	06	30.5 [1.20]	25.40 [10.00]
		398804307	398800307	07	35.6 [1.40]	30.48 [12.00]
398890028		398804308	398800308	08	40.6 [1.60]	35.56 [14.00]
		398804309	398800309	09	45.7 [1.80]	40.64 [16.00]
		398804310	398800310	10	50.8 [2.00]	45.72 [18.00]
		398804311	398800311	11	55.9 [2.20]	50.80 [20.00]
		398804312	398800312	12	61.0 [2.40]	55.88 [22.00]
		398804313	398800313	13	66.0 [2.60]	60.96 [24.00]
		398804314	398800314	14	71.1 [2.80]	66.04 [26.00]
		398804315	398800315	15	76.2 [3.00]	71.12 [28.00]
		398804316	398800316	16	81.3 [3.20]	76.20 [30.00]
		398804317	398800317	17	86.4 [3.40]	81.28 [32.00]
		398804318	398800318	18	91.4 [3.60]	86.36 [34.00]
		398804319	398800319	19	96.5 [3.80]	91.44 [36.00]
		398804320	398800320	20	101.6 [4.00]	96.52 [38.00]
		398804321	398800321	21	106.7 [4.20]	101.60 [40.00]
		398804322	398800322	22	111.8 [4.40]	106.68 [42.00]
		398804323	398800323	23	116.8 [4.60]	111.76 [44.00]
		398804324	398800324	24	121.9 [4.80]	116.84 [46.00]
		398804325	398800325	25	127.0 [5.00]	121.92 [48.00]

ITEM	QTY.	DESCRIPTION	MATERIAL	FINISH
4	XX	SCREW, M3	COPPER ALLOY	NICKEL PLATED
3	XX	CAGE CLAMP (*)	COPPER ALLOY	NICKEL PLATED
2	XX	TERMINAL, PC	COPPER ALLOY	TIN PLATED (E)
1	1	INSULATOR	POLYAMIDE	BLACK

REVISED & REDRAWN

EC NO: WNA2010-0469

DRW:KLYORK 2010/01/26

CHKD:DTITUS 2010/01/26

APPR:DTITUS 2010/02/02

QUALITY SYMBOLS

▽=0

▽=0

GENERAL TOLERANCES (UNLESS SPECIFIED)

	mm	INCH
4 PLACES	± .005	± .0005
3 PLACES	± .005	± .0005
2 PLACES	± 0.13	± .010
1 PLACE	± 0.3	± .010

ANGULAR ± 2 °

DRAFT WHERE APPLICABLE MUST REMAIN WITHIN DIMENSIONS

DIMENSION STYLE: MM/IN

SCALE: 3:1

DESIGN UNITS: INCH

THIRD ANGLE PROJECTION

DRAWN BY: CLYORK DATE: 2010/01/26

CHECKED BY: DTITUS DATE: 2010/01/26

APPROVED BY: DTITUS DATE: 2010/02/01

MATERIAL NO.:

DOCUMENT NO. SD-39880-003

SHEET NO. 1 OF 1

TITLE: 5.08/.200 EUROSTYLE LOW, SINGLE ROW FIXED BLOCK

MOLEX INCORPORATED

THIS DRAWING CONTAINS INFORMATION THAT IS PROPRIETARY TO MOLEX INCORPORATED AND SHOULD NOT BE USED WITHOUT WRITTEN PERMISSION