

PLEASE CHECK WWW.MOLEX.COM FOR LATEST PART INFORMATION

Part Number: [0955022883](#)
Status: **Active**
Overview: [modular_plugs_jacks](#)
Description: Modular Jack, Through Hole, Bottom Entry, 8/8 Circuits

Documents:

[3D Model](#) [Product Specification PS-95502-001 \(PDF\)](#)
[Drawing \(PDF\)](#) [RoHS Certificate of Compliance \(PDF\)](#)

Agency Certification

UL E107635

General

Product Family Modular Jacks/Plugs
 Series [95502](#)
 Component Type PCB Jack
 Magnetic No
 Overview [modular_plugs_jacks](#)
 Performance Category 3
 Power over Ethernet (PoE) N/A
 Product Name RJ11

Physical

Boot Color N/A
 Color - Resin Black
 Durability (mating cycles max) 200
 Flammability 94V-0
 Inverted / Top Latch No
 Lightpipes/LEDs None
 Material - Metal Phosphor Bronze
 Material - Plating Mating Gold
 Material - Plating Termination Tin
 Material - Resin High Temperature Thermoplastic
 Orientation Bottom Entry
 PCB Locator Yes
 PCB Retention Yes
 PCB Thickness Recommended (in) 0.062 In
 PCB Thickness Recommended (mm) 1.57 mm
 Packaging Type Tray
 Pitch - Mating Interface (in) 0.040 In
 Pitch - Mating Interface (mm) 1.02 mm
 Pitch - Term. Interface (in) 0.050 In
 Pitch - Term. Interface (mm) 1.27 mm
 Plating min: Mating (µin) 50.8
 Plating min: Mating (µm) 1.27
 Plating min: Termination (µin) 76
 Plating min: Termination (µm) 1.9
 Ports 1
 Positions / Loaded Contacts 8/8
 Surface Mount Compatible (SMC) Yes
 Temperature Range - Operating -40°C to +80°C
 Termination Interface: Style Through Hole
 Waterproof / Dustproof No
 Wire/Cable Type N/A

Electrical

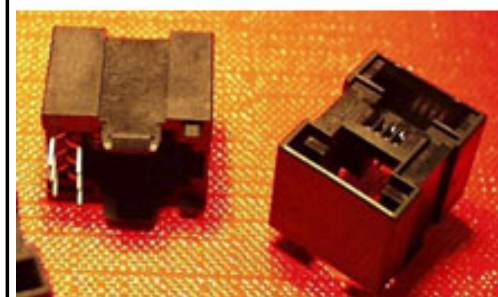

Series

image - Reference only

EU RoHS

**ELV and RoHS
 Compliant
 REACH SVHC
 Contains SVHC: No
 Halogen-Free
 Status**

China RoHS



**Need more information on product
 environmental compliance?**

Email productcompliance@molex.com
 For a multiple part number RoHS Certificate of
 Compliance, [click here](#)

Please visit the [Contact Us](#) section for any
 non-product compliance questions.

Search Parts in this Series

[95502Series](#)

Mates With

[90075 FCC 68 Plug](#)

Current - Maximum per Contact	1.5A
Shielded	No
Voltage - Maximum	125V DC

Solder Process Data

Duration at Max. Process Temperature (seconds)	3
Lead-free Process Capability	Wave Capable (TH only)
Max. Cycles at Max. Process Temperature	1
Process Temperature max. C	260

Material Info

Reference - Drawing Numbers

Packaging Specification	PK-95002
Product Specification	PS-95502-001
Sales Drawing	SD-95502-001

This document was generated on 06/07/2010

PLEASE CHECK WWW.MOLEX.COM FOR LATEST PART INFORMATION

NOTES :

1- MATERIAL:

-HOUSING: L C P FIBER GLASS FILLED
UL 94-V0 COLOR BLACK.

-MODULE : L C P FIBER GLASS FILLED
UL 94-V0 COLOR BLACK.

-TERMINAL: PHOSPHOR BRONZE .

PLATING:

POST PLATE 0.00127-0.00152/.000050-.000060 GOLD
IN CONTACT AREA.

0.00190/.000075 MIN PURE TIN IN TAIL AREA
BOTH OVER 0.00127/.000050 MIN NICKEL OVERALL.

- 2- JACK FOR MATING WITH FCC 68 PLUGS
90075 MOLEX SERIES.
- 3- PCB THICKNESS : 1.57 / .062
- 4- PRODUCT SPECIFICATION PS-95502-001
- 5- PACKAGING SPECIFICATION PK-95002

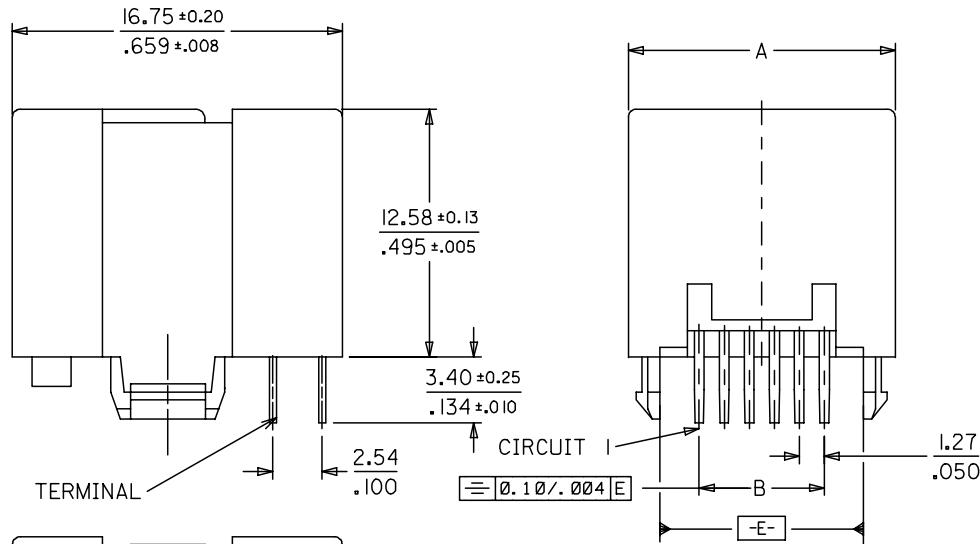
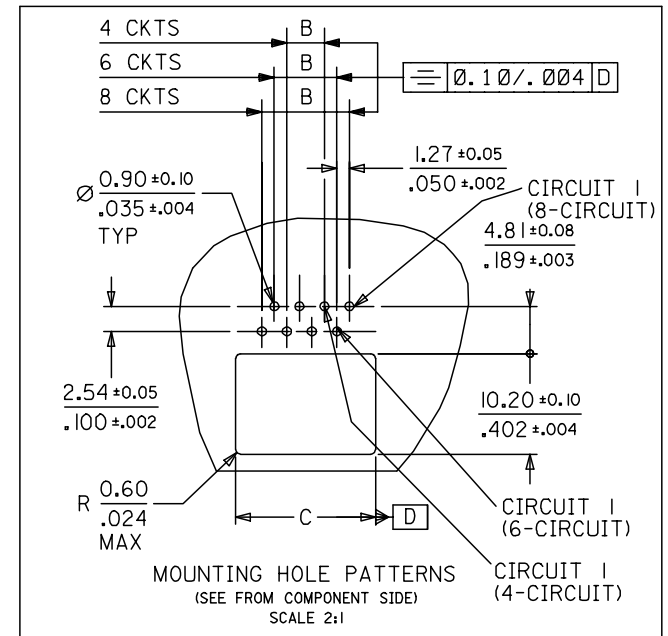

P/N	HOUSING SIZE	CKTS.	DIM.		
			A ±0.13	B $\begin{matrix} +0.05 \\ -0.10 \\ \pm.002 \\ -.004 \end{matrix}$	C $\begin{matrix} \pm.008 \\ \pm.003 \end{matrix}$
95502-2443	POS 4	4 CKTS	$\frac{11.50}{.453}$	$\frac{3.81}{.150}$	$\frac{10.20}{.402}$
95502-2643	POS 6	4 CKTS	$\frac{13.55}{.533}$	$\frac{3.81}{.150}$	$\frac{12.20}{.480}$
95502-2663	POS 6	6 CKTS	$\frac{13.55}{.533}$	$\frac{6.35}{.250}$	$\frac{12.20}{.480}$
95502-2883	POS 8	8 CKTS	$\frac{15.55}{.612}$	$\frac{8.89}{.350}$	$\frac{14.20}{.559}$

MODIFIED MATL. EC NO: E2007-0611 DRWN:DBYRNES 2007/01/22 CHKD: 2007/01/22 APPR:EOMAHONY 2007/01/25	QUALITY SYMBOLS	GENERAL TOLERANCES (UNLESS SPECIFIED)		DIMENSION STYLE	SCALE	DESIGN UNITS	THIRD ANGLE PROJECTION	
	$\nabla=0$ $\sphericalangle=0$	mm	INCH	MM/IN	4:1	METRIC		
		4 PLACES ± --- ± ---	3 PLACES ± --- ±.006	2 PLACES ±0.15 ±.010	1 PLACE ±0.25 ± ---			
		ANGULAR ±.5 °		DRAWN BY DATE		TITLE		
	DRAFT WHERE APPLICABLE MUST REMAIN WITHIN DIMENSIONS		CHECKED BY DATE		MOLEX INCORPORATED			
			APPROVED BY DATE		DOCUMENT NO.		SHEET NO.	
			MATERIAL NO.		SD-95502-001		1 OF 1	
			SIZE		THIS DRAWING CONTAINS INFORMATION THAT IS PROPRIETARY TO MOLEX INCORPORATED AND SHOULD NOT BE USED WITHOUT WRITTEN PERMISSION			