

Philips Components

Document No.	853-0629
ECN No.	99800
Date of Issue	June 14, 1990
Status	Product Specification
ECL Products	

100166

9-Bit Comparator

FEATURES

- Typical propagation delay: 2.3ns
- Typical supply current ($-I_{EE}$): 140mA

DESCRIPTION

The 100166 is a 9-bit Comparator which compares the arithmetic values of two 9-bit words (A and B) and indicates whether one word is greater than, less than, or equal to the other one.

All unused inputs can be left open due to integrated pull-down resistors.

PIN DESCRIPTION

PINS	DESCRIPTION
A ₀ - A ₈	A Data Inputs
B ₀ - B ₈	B Data Inputs
A > B	A Greater Than B Output
B > A	B Greater Than A Output
$\overline{A=B}$	A Equal to B Output (Active Low)

IEC/IEEE SYMBOL

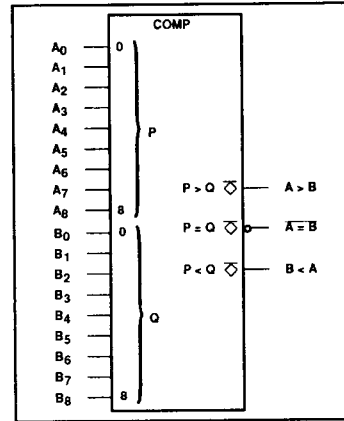

ORDERING INFORMATION

DESCRIPTION	ORDER CODE
24-Pin Ceramic DIP (400 mils wide)	100166F
24-Pin Ceramic Flat Pack	100166Y
28-Pin PLCC	100166A

PIN CONFIGURATIONS

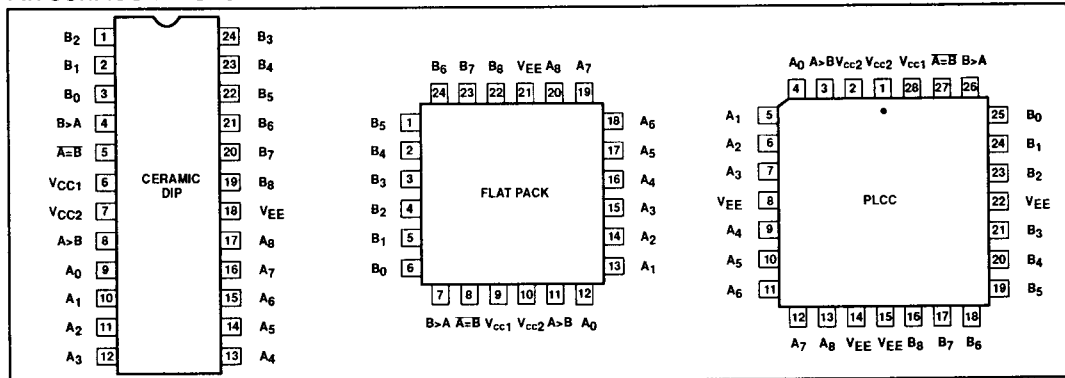

Comparator

100166

LOGIC DIAGRAM

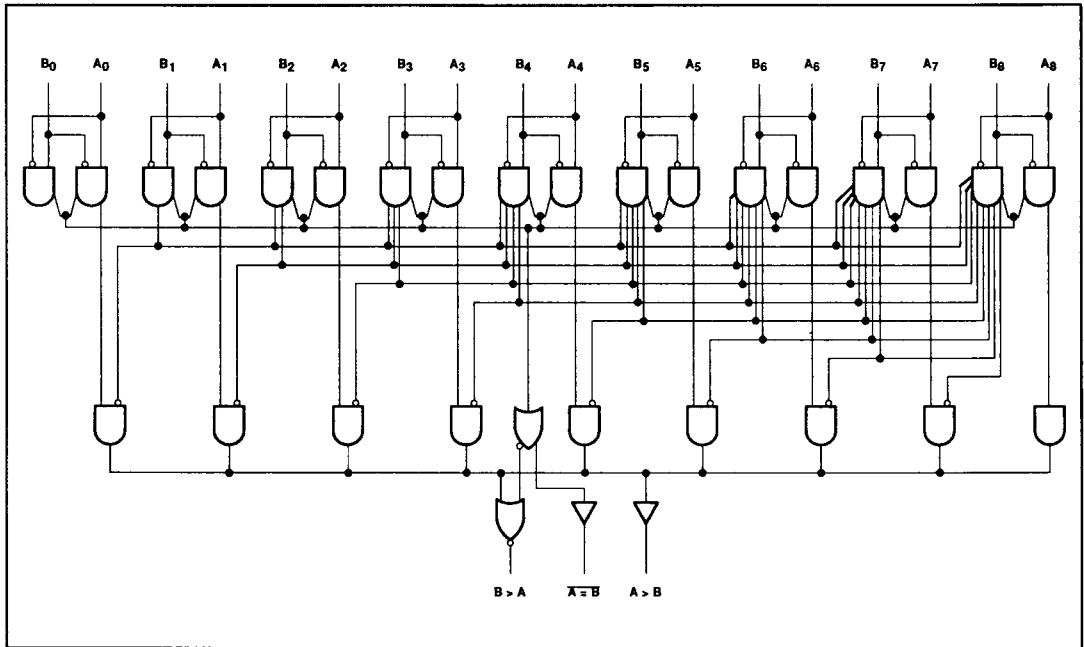

FUNCTION TABLE

INPUTS									OUTPUTS		
A ₀ , B ₀	A ₁ , B ₁	A ₂ , B ₂	A ₃ , B ₃	A ₄ , B ₄	A ₅ , B ₅	A ₆ , B ₆	A ₇ , B ₇	A ₈ , B ₈	A > B	B > A	A = B
								H L L H A ₈ = B ₈ A ₈ = B ₈	H L H L	L H L H	H H H H
					H L L H A ₅ = B ₅ A ₅ = B ₅	H L L H A ₆ = B ₆ A ₆ = B ₆	A ₇ = B ₇ A ₇ = B ₇ A ₇ = B ₇ A ₇ = B ₇	A ₈ = B ₈ A ₈ = B ₈ A ₈ = B ₈ A ₈ = B ₈	H L H L	L H L H	H H H H
			H L L H A ₃ = B ₃ A ₃ = B ₃	H L L H A ₄ = B ₄ A ₄ = B ₄	A ₅ = B ₅ A ₅ = B ₅ A ₅ = B ₅ A ₅ = B ₅	A ₆ = B ₆ A ₆ = B ₆ A ₆ = B ₆ A ₆ = B ₆	A ₇ = B ₇ A ₇ = B ₇ A ₇ = B ₇ A ₇ = B ₇	A ₈ = B ₈ A ₈ = B ₈ A ₈ = B ₈ A ₈ = B ₈	H L H L	L H L H	H H H H
	H L L H A ₁ = B ₁ A ₁ = B ₁	H L L H A ₂ = B ₂ A ₂ = B ₂	A ₃ = B ₃ A ₃ = B ₃ A ₃ = B ₃ A ₃ = B ₃	A ₄ = B ₄ A ₄ = B ₄ A ₄ = B ₄ A ₄ = B ₄	A ₅ = B ₅ A ₅ = B ₅ A ₅ = B ₅ A ₅ = B ₅	A ₆ = B ₆ A ₆ = B ₆ A ₆ = B ₆ A ₆ = B ₆	A ₇ = B ₇ A ₇ = B ₇ A ₇ = B ₇ A ₇ = B ₇	A ₈ = B ₈ A ₈ = B ₈ A ₈ = B ₈ A ₈ = B ₈	H L H L	L H L H	H H H H
H L L H A ₀ = B ₀	A ₁ = B ₁ A ₁ = B ₁ A ₁ = B ₁	A ₂ = B ₂ A ₂ = B ₂ A ₂ = B ₂	A ₃ = B ₃ A ₃ = B ₃ A ₃ = B ₃	A ₄ = B ₄ A ₄ = B ₄ A ₄ = B ₄	A ₅ = B ₅ A ₅ = B ₅ A ₅ = B ₅	A ₆ = B ₆ A ₆ = B ₆ A ₆ = B ₆	A ₇ = B ₇ A ₇ = B ₇ A ₇ = B ₇	A ₈ = B ₈ A ₈ = B ₈ A ₈ = B ₈	H L L	L H L	H H L

NOTES:
 H = High voltage level
 L = Low voltage level
 Blank = Don't care

Comparator

100166

ABSOLUTE MAXIMUM RATINGS $V_{CC1} = V_{CC2} = \text{ground}$, $T_A = 0^\circ\text{C}$ to $+85^\circ\text{C}$ unless otherwise specified.

SYMBOL	PARAMETER	LIMITS	UNIT
V_{EE}	Supply voltage range	-7.0 to +0.5	V
V_{IN}	Input voltage (V_{IN} should never be more negative than V_{EE})	V_{EE} to +0.5	V
I_O	Output source current (continuous)	-55	mA
T_S	Storage temperature range	-65 to +150	$^\circ\text{C}$
T_J	Maximum junction temperature	+150	$^\circ\text{C}$

NOTE:

Operation beyond the limits set forth in this table may impair the useful life of the device.

DC OPERATING CONDITIONS

SYMBOL	PARAMETER	TEST CONDITIONS	LIMITS			UNIT
			MIN.	NOM.	MAX.	
V_{CC1}, V_{CC2}	Circuit ground		0	0	0	V
V_{EE}	Supply voltage		-4.8	-4.5	-4.2	V
V_{EE}	Supply voltage when operating with the 10K or the 10KH ECL family		-5.7			V
V_{IH}	High level input voltage	$V_{EE} = -4.2\text{V}$	-1150			mV
		$V_{EE} = -4.5\text{V}$	-1165		-880	
		$V_{EE} = -4.8\text{V}$	-1165			
V_{IL}	Low level input voltage	$V_{EE} = -4.2\text{V}$			-1475	mV
		$V_{EE} = -4.5\text{V}$	-1810		-1475	mV
		$V_{EE} = -4.8\text{V}$			-1490	mV
T_A	Operating ambient temperature range		0	+25	+85	$^\circ\text{C}$

NOTE:

When operating at other than the specified V_{EE} voltages (-4.2V, -4.5V, -4.8V), the DC and AC electrical characteristics will vary slightly from their specified values.

Comparator

100166

DC ELECTRICAL CHARACTERISTICS

$V_{CC1} = V_{CC2} = \text{ground}$, $V_{EE} = -4.8\text{V}$ to -4.2V , $T_A = 0^\circ\text{C}$ to $+85^\circ\text{C}$ unless otherwise specified^{1,3,4}

SYMBOL	PARAMETER	TEST CONDITIONS ²		LIMITS			UNIT	
				MIN.	TYP.	MAX.		
V_{OH}	High level output voltage		Inputs at V_{IHMAX} or V_{ILMIN} .	$V_{EE} = -4.2\text{V}$	-1020		-870	mV
				$V_{EE} = -4.5\text{V}$	-1025	-955	-880	mV
				$V_{EE} = -4.8\text{V}$	-1035		-880	mV
V_{OHT}	High level output threshold voltage	Outputs loaded with 50Ω to -2.0V $\pm 0.010\text{V}$	Apply V_{IHMIN} or V_{ILMAX} to one input at a time. Other inputs at V_{IHMAX} or V_{ILMIN} .	$V_{EE} = -4.2\text{V}$	-1030			mV
				$V_{EE} = -4.5\text{V}$	-1035			mV
				$V_{EE} = -4.8\text{V}$	-1045			mV
V_{OLT}	Low level output threshold voltage		Apply V_{IHMIN} or V_{ILMAX} to one input at a time. Other inputs at V_{IHMAX} or V_{ILMIN} .	$V_{EE} = -4.2\text{V}$			-1595	mV
				$V_{EE} = -4.5\text{V}$			-1610	mV
				$V_{EE} = -4.8\text{V}$			-1610	mV
V_{OL}	Low level output voltage		Inputs at V_{IHMAX} or V_{ILMIN} .	$V_{EE} = -4.2\text{V}$	-1810		-1605	mV
				$V_{EE} = -4.5\text{V}$	-1810	-1705	-1620	mV
				$V_{EE} = -4.8\text{V}$	-1830		-1620	mV
I_{IH}	High level input current	One input under test at V_{IHMAX} . Other inputs at V_{ILMIN} .					250	μA
I_{IL}	Low level input current	One input under test at V_{ILMIN} . Other inputs at V_{IHMAX} .		0.5				μA
$-I_{EE}$	V_{EE} supply current	All inputs at V_{IHMAX}		119	140	238		mA

NOTES:

- The specified limits represent the worst case values for the parameter. Since these worst case values normally occur at the supply voltage and temperature extremes, additional noise immunity can be achieved by decreasing the allowable operating condition ranges.
- Conditions for testing shown in the tables are not necessarily worst case. For worst case testing guidelines, refer to DC Testing, Chapter 1, Section 3.
- The specified limits shown in the DC electrical characteristics table can be met only after thermal equilibrium has been established. Thermal equilibrium is established by applying power for at least 2 minutes, while maintaining transverse airflow of 2.5 meters/sec (500 linear feet/min) over the device, mounted either in a test socket or on a printed circuit board. Test voltage values are given in the DC operating conditions table.
- The device can function down to $V_{EE} = -5.7\text{V}$, allowing operation with either the 10K or the 10KH family. Correction factors can be used to calculate new DC limits for the extended V_{EE} range. For more information, see Chapters 5 and 10, Section 4.

AC ELECTRICAL CHARACTERISTICS

Ceramic DIP $V_{CC1} = V_{CC2} = \text{ground}$, $V_{EE} = -4.8\text{V}$ to -4.2V

SYMBOL	PARAMETER	TEST CONDITION	LIMITS						UNIT
			$T_A = 0^\circ\text{C}$		$T_A = +25^\circ\text{C}$		$T_A = +85^\circ\text{C}$		
			MIN.	MAX.	MIN.	MAX.	MIN.	MAX.	
t_{PLH} t_{PHL}	Propagation delay Any input to any output	Waveform 1	1.40	3.50	1.40	3.50	1.40	3.90	ns
			1.40	3.50	1.40	3.50	1.40	3.90	ns
t_{TLH} t_{THL}	Transition time for all outputs		0.45	1.60	0.45	1.60	0.45	1.60	ns
			0.45	1.60	0.45	1.60	0.45	1.60	ns

NOTE:

For AC test setup information, see AC Testing, Chapter 2, Section 3.

Comparator

100166

AC ELECTRICAL CHARACTERISTICS

Ceramic DIP $V_{CC1} = V_{CC2} = \text{ground}$, $V_{EE} = -5.2V \pm 5\%$

SYMBOL	PARAMETER	TEST CONDITION	LIMITS						UNIT
			$T_A = 0^\circ\text{C}$		$T_A = +25^\circ\text{C}$		$T_A = +85^\circ\text{C}$		
			MIN.	MAX.	MIN.	MAX.	MIN.	MAX.	
t_{PLH} t_{PHL}	Propagation delay Any input to any output	Waveform 1	1.40	3.50	1.40	3.50	1.40	3.90	ns
t_{TLH} t_{THL}	Transition time for all outputs		0.45	1.60	0.45	1.60	0.45	1.60	ns
			0.45	1.60	0.45	1.60	0.45	1.60	ns

NOTE:

For AC test setup information, see AC Testing, Chapter 2, Section 3.

AC ELECTRICAL CHARACTERISTICS

Flat Pack and PLCC $V_{CC1} = V_{CC2} = \text{ground}$, $V_{EE} = -4.8V$ to $-4.2V$

SYMBOL	PARAMETER	TEST CONDITION	LIMITS						UNIT
			$T_A = 0^\circ\text{C}$		$T_A = +25^\circ\text{C}$		$T_A = +85^\circ\text{C}$		
			MIN.	MAX.	MIN.	MAX.	MIN.	MAX.	
t_{PLH} t_{PHL}	Propagation delay Any input to any output	Waveform 1	1.40	3.30	1.40	3.30	1.40	3.70	ns
t_{TLH} t_{THL}	Transition time for all outputs		0.45	1.60	0.45	1.60	0.45	1.60	ns
			0.45	1.60	0.45	1.60	0.45	1.60	ns

NOTE:

For AC test setup information, see AC Testing, Chapter 2, Section 3.

AC ELECTRICAL CHARACTERISTICS

Flat Pack and PLCC $V_{CC1} = V_{CC2} = \text{ground}$, $V_{EE} = -5.2V \pm 5\%$

SYMBOL	PARAMETER	TEST CONDITION	LIMITS						UNIT
			$T_A = 0^\circ\text{C}$		$T_A = +25^\circ\text{C}$		$T_A = +85^\circ\text{C}$		
			Min	Max	Min	Max	Min	Max	
t_{PLH} t_{PHL}	Propagation delay Any input to any output	Waveform 1	1.40	3.30	1.40	3.30	1.40	3.70	ns
t_{TLH} t_{THL}	Transition time for all outputs		0.45	1.60	0.45	1.60	0.45	1.60	ns
			0.45	1.60	0.45	1.60	0.45	1.60	ns

NOTE:

For AC test setup information, see AC Testing, Chapter 2, Section 3.

AC WAVEFORMS

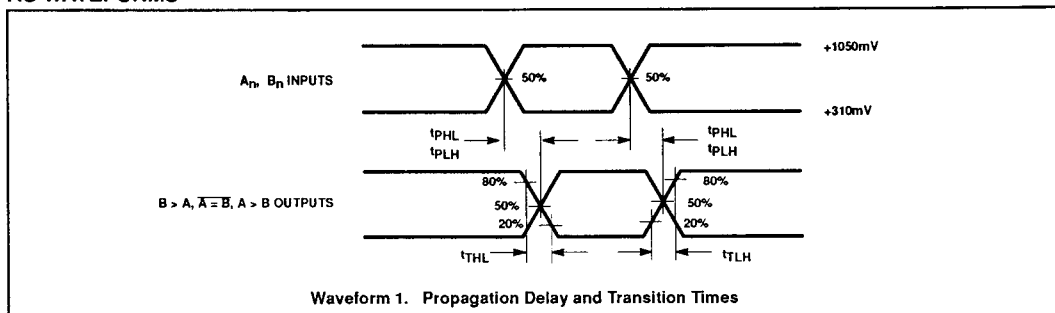

NOTE:

All power and signal voltages shifted up 2.0V for AC bench test purposes.