

Model 1448 High Power, 7/16 Connectors Convection Cooled, Low IMD Design

**dc to 6.0 GHz
 150 Watts**



Features

- /// Optimized for Wireless OEM and Test Applications.
- /// Designed to meet environmental requirements of MIL-D-39030.
- /// Custom Designs Available.

Specifications

NOMINAL IMPEDANCE: 50 Ω

FREQUENCY RANGE: dc to 6.0 GHz

MAXIMUM SWR:

Frequency (GHz)	SWR
dc - 6	1.25

INTERMODULATION: Third Order Reflected Levels (IM3), -100 dBc with two input signals @ 869 MHz and 891 MHz with average carrier power levels of +43 dBm each.

POWER RATING: 150 watts **average (mounted horizontally assuming unobstructed air flow and natural convection around unit)** @ 25°C ambient temperature, derated linearly to 15 watts @ 125°C. 10 kilowatts **peak** (5 μsec pulse width; 0.75% duty cycle).

TEMPERATURE RANGE: -55°C to +125°C

TEST DATA: Swept data plots of SWR from 50 MHz to 6 GHz is available at additional cost.

CONNECTOR: 7/16 connector that conforms to DIN 47 223, IEC 1694, VG 95250, CECC 22190. Choice of 7/16 male (-2) or 7/16 female (-1) connector.

CONSTRUCTION: Black, finned aluminum body, silver plated brass connector.

WEIGHT: 1,248 g (2.75 lbs)

PHYSICAL DIMENSIONS:

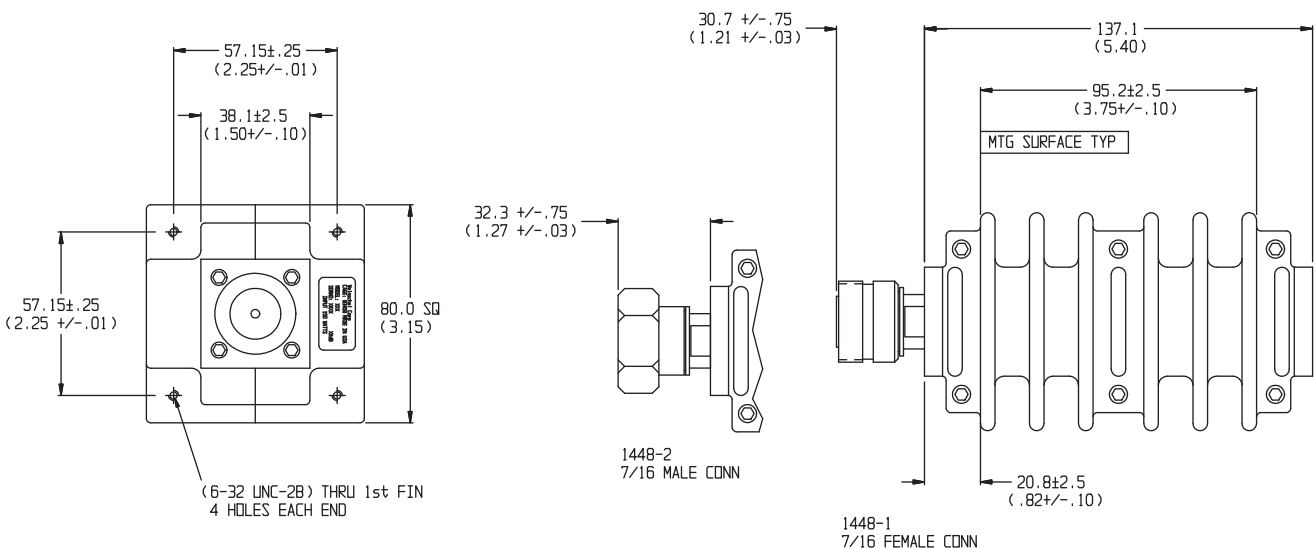

NOTE: All dimensions are given in mm (inches) and are maximum, unless otherwise specified.