

Aluminum Capacitors Radial Long-Life, High Voltage

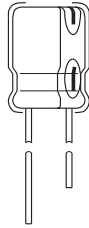
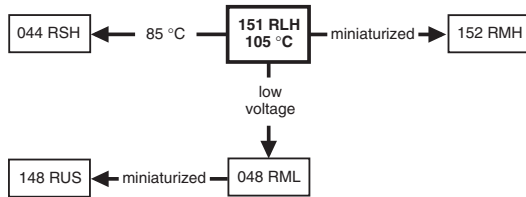


Fig.1 Component outline.



QUICK REFERENCE DATA	
DESCRIPTION	VALUE
Nominal case sizes (∅D × L in mm)	10 × 12 to 18 × 35
Rated capacitance range, C _R	1 to 220 μF
Tolerance on C _R	±20%
Rated voltage range, U _R	160 to 450 V
Category temperature range	-40 to +105 °C
Endurance test at 105 °C	2000 hours
Useful life at 105 °C: case ∅D = 10 and 12.5 mm case ∅D = 16 and 18 mm	3000 hours 4000 hours
Useful life at 40 °C, 1.6 × I _R applied: case ∅D = 10 and 12.5 mm case ∅D = 16 and 18 mm	200000 hours 260000 hours
Shelf life at 0 V, 105 °C	500 hours
Based on sectional specification	IEC 60384-4/EN130300
Climatic category IEC 60068	40/105/56

FEATURES

- Polarized aluminum electrolytic capacitors, non-solid electrolyte
- Radial leads, cylindrical aluminum case, insulated with a blue vinyl sleeve
- Pressure relief
- Charge and discharge proof
- Long useful life: 3000 to 4000 hours at 105 °C, high reliability
- High rated voltage, up to 450 V

APPLICATIONS

- High-reliability and professional applications
- Lighting, monitors, consumer electronics, general industrial
- Filtering of high voltages in power supplies.

MARKING

The capacitors are marked (where possible) with the following information:

- Rated capacitance value (in μF).
- Tolerance on rated capacitance, code letter in accordance with IEC 60062 (M for ±20%).
- Rated voltage (in V).
- Date code, in accordance with IEC 60062.
- Code indicating factory of origin.
- Name of manufacturer.
- Upper category temperature (105 °C).
- Negative terminal identification.
- Series number (151).

SELECTION CHART FOR C _R , U _R AND RELEVANT NOMINAL CASE SIZES (∅D x L in mm)						
C _R (μF)	U _R (V)					
	160	200	250	350	400	450
1.0	-	-	-	-	-	10 × 12
2.2	-	-	-	-	10 × 12	10 × 16
3.3	-	-	-	10 × 12	10 × 16	10 × 20
4.7	-	10 × 12	10 × 12	10 × 16	10 × 20	12.5 × 20
10	10 × 16	10 × 16	10 × 20	12.5 × 20	12.5 × 20	16 × 20
22	10 × 20	10 × 20	12.5 × 25	12.5 × 25	16 × 25	16 × 31
33	-	-	16 × 20	16 × 20	18 × 20	18 × 25
	12.5 × 20	12.5 × 20	12.5 × 25	16 × 25	16 × 31	18 × 35
	-	-	16 × 20	-	18 × 25	-
47	12.5 × 25	12.5 × 25	16 × 25	16 × 35	18 × 31	-
	16 × 20	16 × 20	18 × 20	18 × 31	-	-
100	16 × 25	16 × 31	16 × 31	-	-	-
	18 × 20	18 × 25	18 × 25	-	-	-
220	18 × 35	-	-	-	-	-

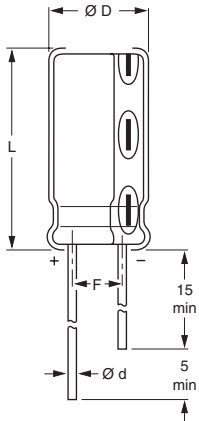
DIMENSIONS in millimeters AND AVAILABLE FORMS


Fig.2 Form CA: Long leads.

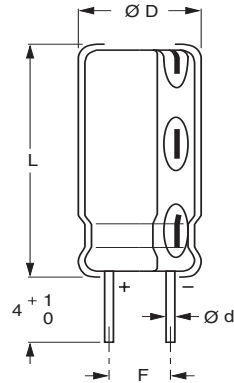


Fig.2 Form CB: Cut leads.

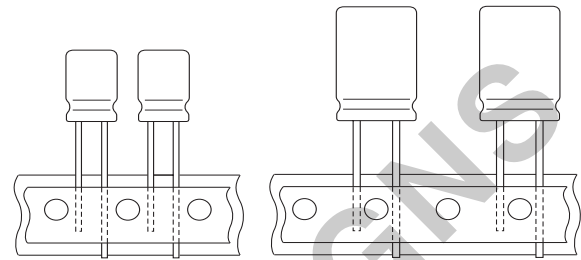

 Case $\text{ØD} \times L \leq 16 \times 31$ mm.

Fig.4 Form TFA Taped in box (ammopack).

Table 1

DIMENSIONS in millimeters, MASS AND PACKAGING QUANTITIES									
NOMINAL CASE SIZE $\text{ØD} \times L$	CASE CODE	Ød	ØD_{max}	L_{max}	F	MASS (g)	PACKAGING QUANTITIES PER BOX		
							FORM CA	FORM CB	FORM TFA
10 × 12	14	0.6	10.5	13.5	5.0 ± 0.5	≈1.6	1000	500	800
10 × 16	15	0.6	10.5	17.5	5.0 ± 0.5	≈1.9	500	500	800
10 × 20	16	0.6	10.5	22.0	5.0 ± 0.5	≈2.2	500	500	800
12.5 × 20	17	0.6	13.0	22.0	5.0 ± 0.5	≈4.0	500	500	500
12.5 × 25	18	0.6	13.0	27.0	5.0 ± 0.5	≈5.0	250	250	500
16 × 20	19a	0.8	16.5	22.0	7.5 ± 0.5	≈6.0	250	250	250
16 × 25	19	0.8	16.5	27.0	7.5 ± 0.5	≈8.0	250	250	250
16 × 31	20	0.8	16.5	33.5	7.5 ± 0.5	≈9.0	100	100	250
16 × 35	21	0.8	16.5	37.5	7.5 ± 0.5	≈11.0	100	100	–
18 × 20	1820	0.8	18.5	22.0	7.5 ± 0.5	≈8.0	100	100	–
18 × 25	1825	0.8	18.5	27.0	7.5 ± 0.5	≈10.0	100	100	–
18 × 31	1831	0.8	18.5	33.5	7.5 ± 0.5	≈12.5	100	100	–
18 × 35	22	0.8	18.5	37.5	7.5 ± 0.5	≈14.5	100	100	–

ELECTRICAL DATA	
SYMBOL	DESCRIPTION
C_R	rated capacitance at 100 Hz, tolerance $\pm 20\%$
I_R	rated RMS ripple current at 100 Hz, 105 °C
I_{L1}	max. leakage current after 1 minute at U_R
Tan δ	max. dissipation factor at 100 Hz
Z	max. impedance at 10 kHz

Note

1. Unless otherwise specified, all electrical values in Table 2 apply at $T_{amb} = 20\text{ °C}$, $P = 86$ to 106 kPa , $RH = 45$ to 75% .

ORDERING EXAMPLE

Electrolytic capacitor 151 series

4.7 $\mu\text{F}/400\text{ V}$; $\pm 20\%$

Nominal case size: $\varnothing 10 \times 20\text{ mm}$; Form TFA

Catalog number: 2222 151 36478.

Table 2

ELECTRICAL DATA AND ORDERING INFORMATION									
U_R (V)	C_R 100 Hz (μF)	NOMINAL CASE SIZE $\varnothing D \times L$ (mm)	I_R 100 Hz 105 °C (mA)	I_{L1} 1 min (μA)	Tan δ 100 Hz	Z 10 kHz (Ω)	CATALOG NUMBER 2222 151		
							BULK PACKAGING		TAPED
							FORM CA	FORM CB	FORM TFA
160	10	10 × 16	95	118	0.12	6.3	51109	61109	31109
	22	10 × 20	145	176	0.12	3.2	51229	61229	31229
	33	12.5 × 20	190	228	0.12	2.3	51339	61339	31339
	47	12.5 × 25	280	296	0.12	1.7	51479	61479	31479
	47	16 × 20	280	296	0.12	1.7	91475	91476	91473
	100	16 × 25	380	550	0.12	1.1	51101	61101	31101
	100	18 × 20	380	550	0.12	1.1	91105	91106	–
	220	18 × 35	630	1126	0.12	0.8	51221	61221	–
200	4.7	10 × 12	60	96	0.12	13.0	52478	62478	32478
	10	10 × 16	95	130	0.12	6.3	52109	62109	32109
	22	10 × 20	145	202	0.12	3.2	52229	62229	32229
	33	12.5 × 20	190	268	0.12	2.3	52339	62339	32339
	47	12.5 × 25	280	352	0.12	1.7	52479	62479	32479
	47	16 × 20	280	352	0.12	1.7	92475	92476	92473
	100	16 × 31	410	670	0.12	1.1	52101	62101	32101
	100	18 × 25	410	670	0.12	1.1	92105	92106	–
250	4.7	10 × 12	60	105	0.12	13.0	53478	63478	33478
	10	10 × 20	105	145	0.12	6.3	53109	63109	33109
	22	12.5 × 25	180	235	0.12	3.2	53229	63229	33229
	22	16 × 20	180	235	0.12	3.2	93225	93226	93223
	33	12.5 × 25	250	318	0.12	2.3	53339	63339	33339
	33	16 × 20	250	318	0.12	2.3	93335	93336	93333
	47	16 × 25	300	423	0.12	1.7	53479	63479	33479
	47	18 × 20	300	423	0.12	1.7	93475	93476	–
	100	16 × 31	410	820	0.12	1.1	53101	63101	33101
	100	18 × 25	410	820	0.12	1.1	93105	93106	–



Aluminum Capacitors
Radial Long-Life, High Voltage

Vishay BCcomponents

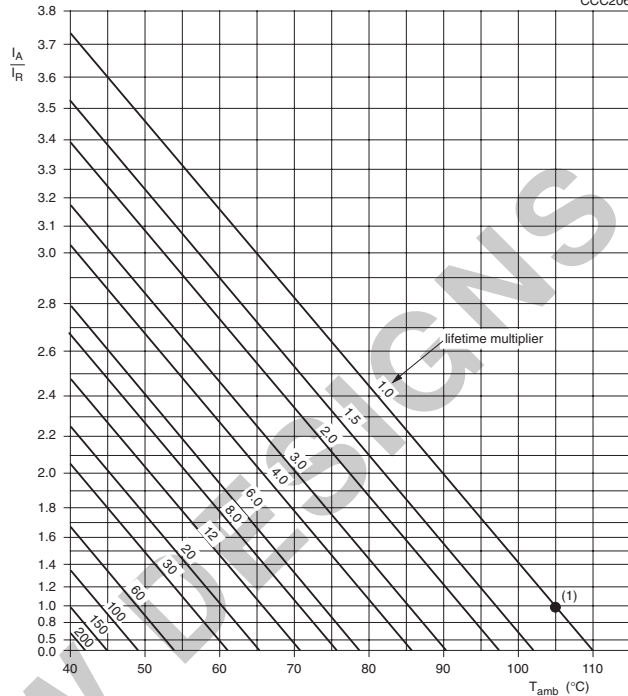
ELECTRICAL DATA AND ORDERING INFORMATION									
U _R (V)	C _R 100 Hz (μF)	NOMINAL CASE SIZE ∅D × L (mm)	I _R 100 Hz 105 °C (mA)	I _{L1} 1 min (μA)	Tan δ 100 Hz	Z 10 kHz (Ω)	CATALOG NUMBER 2222 151		
							BULK PACKAGING		TAPED
							FORM CA	FORM CB	FORM TFA
350	3.3	10 × 12	50	105	0.15	22.0	55338	65338	35338
	4.7	10 × 16	65	119	0.15	16.0	55478	65478	35478
	10	12.5 × 20	120	175	0.15	7.6	55109	65109	35109
	22	12.5 × 25	180	301	0.15	3.8	55229	65229	35229
	22	16 × 20	180	301	0.15	3.8	95225	95226	95223
	33	16 × 25	210	417	0.15	2.6	55339	65339	35339
	47	16 × 35	300	564	0.15	2.0	55479	65479	-
	47	18 × 31	300	564	0.15	2.0	95475	95476	-
400	2.2	10 × 12	40	93	0.15	33.0	56228	66228	36228
	3.3	10 × 16	50	110	0.15	22.0	56338	66338	36338
	4.7	10 × 20	70	126	0.15	16.0	56478	66478	36478
	10	12.5 × 20	120	190	0.15	7.6	56109	66109	36109
	22	16 × 25	200	334	0.15	3.8	56229	66229	36229
	22	18 × 20	200	334	0.15	3.8	96225	96226	-
	33	16 × 31	245	466	0.15	2.6	56339	66339	36339
	33	18 × 25	245	466	0.15	2.6	96335	96336	-
47	18 × 31	300	634	0.15	2.0	56479	66479	-	
450	1.0	10 × 12	30	67	0.2	94.0	57108	67108	37108
	2.2	10 × 16	45	99	0.2	43.0	57228	67228	37228
	3.3	10 × 20	65	115	0.2	29.0	57338	67338	37338
	4.7	12.5 × 20	80	133	0.2	20.0	57478	67478	37478
	10	16 × 20	140	205	0.2	10.0	57109	67109	37109
	22	16 × 31	220	367	0.2	4.6	57229	67229	37229
	22	18 × 25	220	367	0.2	4.6	97225	97226	-
	33	18 × 35	280	516	0.2	3.4	57339	67339	-

ADDITIONAL ELECTRICAL DATA		
PARAMETER	CONDITIONS	VALUE
Voltage		
Surge voltage	IEC 60384-4, subclause 4.14: U _R = 160 to 250 V U _R = 350 to 400 V	U _s ≤ 1.15 × U _R U _s ≤ 1.10 × U _R
Reverse voltage	IEC 60384-4, subclause 4.15	U _{rev} ≤ 1 V
Current		
Leakage current	after 1 minute at U _R : CV ≤ 1000 μC CV > 1000 μC	I _{L1} ≤ 0.06 C _R × U _R + 40 μA I _{L1} ≤ 0.03 C _R × U _R + 70 μA
	after 5 minutes at U _R : CV ≤ 1000 μC CV > 1000 μC	I _{L5} ≤ 0.03 C _R × U _R + 15 μA I _{L5} ≤ 0.015 C _R × U _R + 30 μA
Inductance		
Equivalent series inductance (ESL)	case ∅D = 10 mm	typ. 16 nH
	case ∅D ≥ 12.5 mm	typ. 18 nH
Resistance		
Equivalent series resistance (ESR)	calculated from tan δ _{max} and C _R (see Table 2)	ESR = tan δ / 2πfC _R



RIPPLE CURRENT AND USEFUL LIFE

CCC206



I_A = actual ripple current at 100 Hz.
 I_R = rated ripple current at 100 Hz, 105 °C.
 (1) Useful life at 105 °C and I_R applied:
 case ØD = 10 and 12.5 mm: 3000 hours
 case ØD = 16 and 18 mm: 4000 hours.

Fig.3 Multiplier of useful life as a function of ambient temperature and ripple current load.

Table 3

MULTIPLIER OF RIPPLE CURRENT (I_R) AS A FUNCTION OF FREQUENCY	
FREQUENCY (Hz)	I_R MULTIPLIER
50	0.75
100	1.00
300	1.20
1000	1.35
3000	1.45
≥10000	1.50

Table 4

TEST PROCEDURES AND REQUIREMENTS			
TEST		PROCEDURE (quick reference)	REQUIREMENTS
NAME OF TEST	REFERENCE		
Endurance	IEC 60384-4/ EN130300 subclause 4.15	$T_{amb} = 105\text{ °C}$; U_R applied; 2000 hours	$\Delta C/C: \pm 20\%$ $\tan \delta \leq 2 \times \text{spec. limit}$ $Z \leq 2 \times \text{spec. limit}$ $I_{L5} \leq \text{spec. limit}$
Useful life	CECC 30301 subclause 1.8.1	$T_{amb} = 105\text{ °C}$; U_R and I_R applied; case ØD = 10 and 12.5 mm: 3000 hours; case ØD = 16 and 18 mm: 4000 hours	$\Delta C/C: \pm 50\%$ $\tan \delta \leq 3 \times \text{spec. limit}$ $Z \leq 3 \times \text{spec. limit}$ $I_{L5} \leq \text{spec. limit}$ no short or open circuit total failure percentage: $\leq 1\%$
Shelf life (storage at high temperature)	IEC 60384-4/ EN130300 subclause 4.17	$T_{amb} = 105\text{ °C}$; no voltage applied; 500 hours after test: U_R to be applied for 30 minutes, 24 to 48 hours before measurement	$\Delta C/C: \pm 20\%$ $\tan \delta \leq 2 \times \text{spec. limit}$ $Z \leq 2 \times \text{spec. limit}$ $I_{L5} \leq 2 \times \text{spec. limit}$