

1542 22 GHz 1310 nm Microwave DFB Laser



Applications

- Antenna Remoting
- Cellular and PCS Networks
- Military Communications
- Tracking, Telemetry, and Control

Features

- High-Dynamic-Range
- Long Distance Communications
- 10 MHz to 22 GHz Bandwidth
- Built-in Optical Isolator
- 1310 nm

The 1542 22 GHz 1310 nm Microwave Distributed Feedback (DFB) Laser provides exceptional performance for linear fiber optics communications in very wide bandwidth applications. EMCORE's linear fiber optics are an excellent alternative to using coaxial cable systems to transmit 10 MHz to 22 GHz signals. They offer significant improvements in reliability of microwave communications networks by transmitting the RF signal in its original format. As a result of these properties, the 1542 provides significant improvements in signal quality for a wide variety of applications including antenna remoting, telemetry, timing and reference signal distribution, measurement and delay lines.

The basic 1542 laser module can be integrated into a complete transmitter either as a flange-mount for extreme environments, or as a plug-in for EMCORE's System 10000 rack-mount system. Electronics within the flange-mount and plug-in transmitters control the laser temperature and DC bias current and provide warnings whenever the temperature or power deviates from their intended levels. This provides a self-regulating, fully-integrated microwave product with excellent noise performance in sensitive optical links.



Performance Highlights

Parameter	Min	Typ	Max	Unit
Available Wavelengths	1290	1310	1340	nm
Optical Output Power	-	9	-	dBm
Temperature Range	-40	-	+65	°C
Frequency Range	10	-	22000	MHz

Typical Data

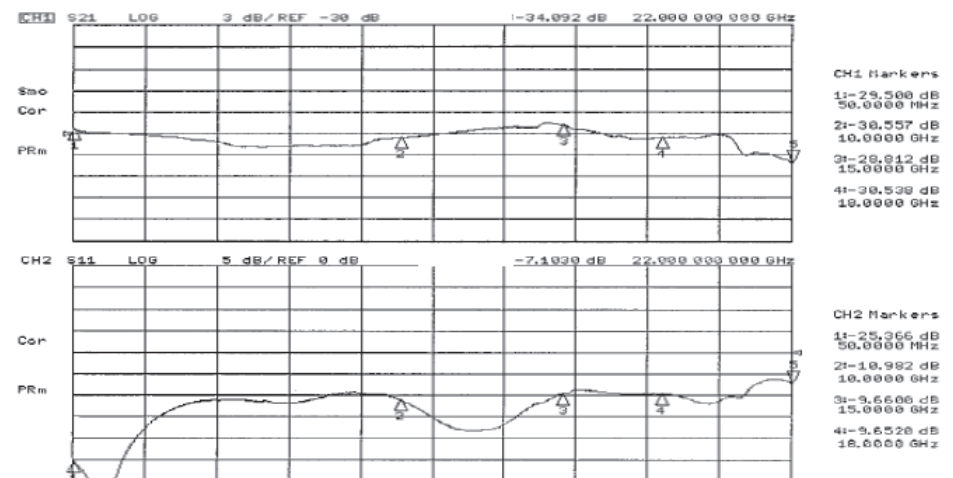

1542 22 GHz 1310 nm Microwave DFB Laser



DATASHEET | AUGUST 2013

MICROWAVE

Absolute Maximum Ratings

Stresses in excess of the absolute maximum ratings can cause permanent damage to the device. These are absolute stress ratings only. Functional operation of the device is not implied at these or any other conditions in excess of those given in the operational sections of the data sheet. Exposure to absolute maximum ratings for extended periods can adversely affect device reliability.

Parameter	Symbol	Condition	Min	Max	Unit
Operating Temperature Range of Baseplate	T_{OP}	Continuous	-40	+65	°C
Storage Temperature	T_{STG}	-	-40	+85	°C
RF Input Power	P_{IN}	60 Seconds	-	+20	dBm
Laser Forward dc Current	-	-	25	120	mA
Photodiode Reverse Voltage	V_{RPD}	-	200	10	V
Laser Reverse Voltage	-	-	-	1	V
ESD	-	HMB: R = 1500 Ohm, C = 100 pF	-500	500	V
TEC Current	I_{TEC}	Continuous	-1.9	1.9	A

Electrical Characteristics

Parameter	Specifications	Unit
Wavelength	1310 to ± 30	nm
Spectral Width, FWHM ² , Typ., Max	10	MHz
Optical Power, Typical @ ITH +55 mA	8 (min)	dBm
Optical Power Stability vs. Temperature	± 15	%
DC Modulations Gain, Typical	0.24	-

1. Specifications guaranteed when unit is connected to an optical path with return loss >35 dB.
2. No RF Input.

DC

Parameter	Symbol	Condition	Min	Max	Units
Laser Bias	I_{OP}	25°C	-	65	mA
Threshold Current	I_{TH}	25°C	-	26	mA
Forward Voltage	V_F	$I_{OP} = I_{TH} + 50$ mA	-	6	V
Thermo Electric Cooler	I_{TEC}	-	-1.1	-	A
Thermistor	R_{TH}	25°C	9.5	10	k Ω
Thermistor Temperature Coefficient	TE_{TH}	25°C	-	4.4	% / °C

Seven-Pin Miniature Rectangular Connector

Pin	Description
A	Thermistor
B	TEC (-)
C	Thermistor
D	TEC (+)
E	Laser Bias
F	Ground
G	Monitor Photodiode

1542 22 GHz 1310 nm Microwave DFB Laser

RF Characteristics

Parameter	Specifications				Unit
	1542B	1542C	1542D	1542E	
Maximum Frequency	7	13	18	22	GHz
Minimum Frequency	0.01				GHz
Amplitude Flatness ^{1,2}	4.0	4.0	5.0	5.0	dB p-p
Input Return Loss (50Ω)	7.0	4.0	4.0	4.0	dB
Input 1 dB Compression	+20				dBm
Input Third Order Intercept ³					
0.01 GHz - 7.0 GHz	+30				
7.0 GHz - 22.0 GHz	+25				
Noise Figure (dB) ⁴					
0.01 GHz - 3.0 GHz	44	44	44	44	
3.0 GHz - 7.0 GHz	50	50	50	50	
7.0 GHz - 13.0 GHz	-	54	54	54	
13.0 GHz - 18.0 GHz	-	-	59	59	
18. GHz - 22.0 GHz	-	-	-	61	

1. Specifications guaranteed when unit is connected to an optical path with return loss >35 dB.
2. Peak to Peak
3. Two Carrier Test
4. No RF Input

Mechanical Drawing (dimensions are in inches)

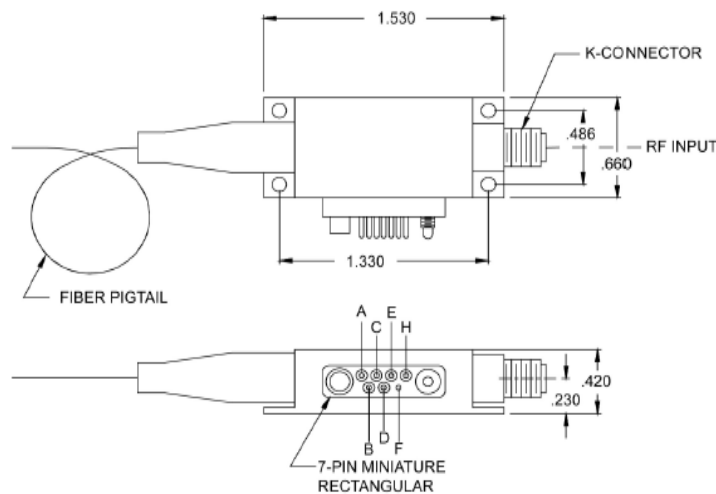

Electrical Schematic

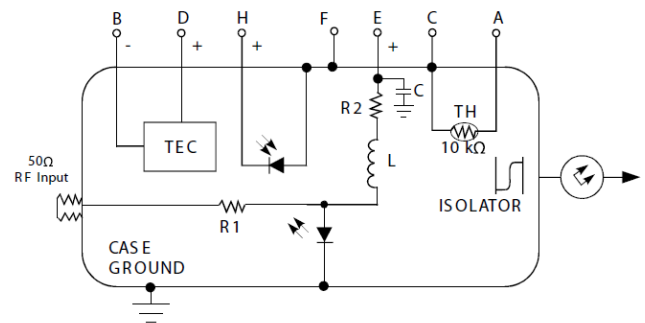

1542 22 GHz 1310 nm Microwave DFB Laser

Ordering Information

1542n-yy-zz

Frequency (n)	Option Code
7 GHz	B
13 GHz	C
18 GHz	D
22 GHz	E

RF Connector (yy)	Option Code
SMA Male	SM
SMA Female	SF

Optical Connector (zz)	Option Code
No optical connector, 900m buffered pigtail	PG
FC/APC optical connector, 900m buffered pigtail	FA
SC/APC, optical connector, 900m buffered pigtail	SA

Laser Safety

This product meets the appropriate standard in Title 21 of the Code of Federal Regulations (CFR). FDA/CDRH Class 1M laser product. This device has been classified with the FDA/CDRH under accession number 0220191. All versions of this laser are Class 1M laser product, tested according to IEC 60825-1:2007 / EN 60825-1:2007. An additional warning for Class 1M laser products. For diverging beams, this warning shall state that viewing the laser output with certain optical instruments (for example, eye loupes, magnifiers and microscopes) within a distance of 100 mm may pose an eye hazard. For collimated beams, this warning shall state that viewing the laser output with certain optical instruments designed for use at a distance (for example, telescopes and binoculars) may pose an eye hazard.

Wavelength = 1.5 μ m.
Maximum power = 30 mW.



Caution: Use of controls, adjustments and procedures other than those specified herein may result in hazardous laser radiation exposure.

*IEC is a registered trademark of the International Electrotechnical Commission.