

used for: D-SUB

POS.	A -0.76	B $+0.25$	C	D -0.3	Part NO.
9	31.19	16.79	25.00 $^{+0.12}_{-0.13}$	6.12	163A11069X
15	39.52	25.12	33.30 $^{+0.15}_{-0.1}$	6.12	163A11079X
25	53.42	38.84	47.04 ± 0.13	5.99	163A11089X
37	69.70	55.30	63.50 ± 0.13	5.99	163A11099X

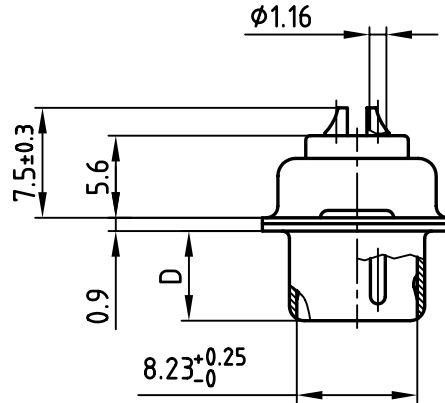
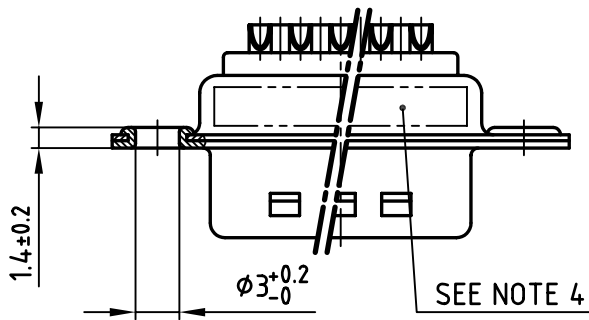
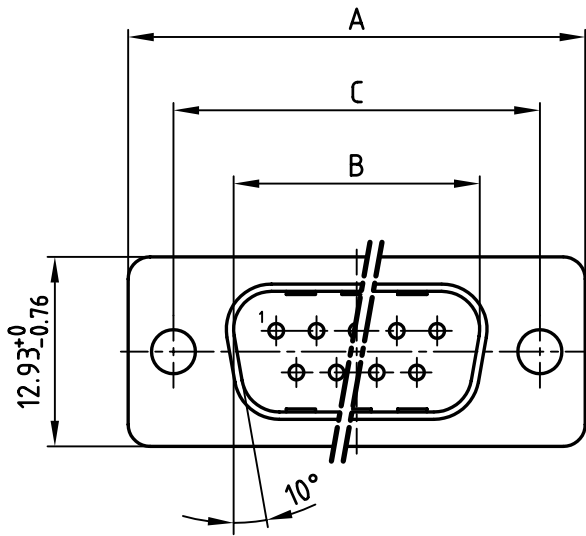

Directive 2002/95/EC
"RoHS"
Compliant

NOTES:

- METALSHELLS: STEEL; min. 315µm TIN over 40-80µm NICKEL
- INSULATORS: PBT GF UL 94 V-0, BLACK
- CONTACTS: COPPER ALLOY
PLATING: 8µm HARD GOLD OVER min. 50µm NICKEL
SOLDER CUP ACCEPTS CABLE AWG 20
- CONNECTOR IS PART MARKED: PART-NO. CONEC ABC

APPROVAL # FREIGABE # DEBLOCAGE # AUTORIZACION # APPROVAL	
CUSTOMER APPROVAL DATE:	
NAME:	TITLE:
COMPANY NAME:	
APPROVAL # FREIGABE # DEBLOCAGE # AUTORIZACION # APPROVAL	

THIS DRAWING MAY NOT BE COPIED OR REPRODUCED IN ANY WAY, AND MAY NOT BE PASSED ON TO A THIRD PARTY WITHOUT WRITTEN PERMISSION.
 OWNERSHIP AND COPYRIGHT OF CONEC GmbH
 DO NOT ALTER CAD DRAWING BY HAND

tolerance		dim. in mm	scale: 2:1	
			material: SEE NOTES	
	1998	date	name	
	drawn	25.08.	Barcinski	
	appd.	25.08.	Mickenbecker	
	norm	DIN 41652		
	d-old			
1 x b	Ä 2535	18.07.2006	Lehmen	
a	Origin			
rev.	description	date	name	



title:		D-SUB MALE 9-37pos. SOLDER CUP	
dwg no:	AutoCAD 2006	DIN-A	
		4	
		sh: 1/1	
part no:	SEE TABLE		

4

3

2

1