

used for: D-SUB

No. of pos.	A ^{-0.76}	B ^{+0.25}	C	D ^{-0.3}	Part No.
9	31.19	16.79	25.00 ^{+0.12} _{-0.13}	6.12	163A11269X
15	39.52	25.12	33.30 ^{+0.15} _{-0.1}	6.12	163A11279X
25	53.42	38.84	47.04 ^{+0.13}	5.99	163A11289X
37	69.70	55.30	63.50 ^{+0.13}	5.99	163A11299X
50	67.31	52.68	61.10 ^{+0.14} _{-0.11}	5.99	163A11309X

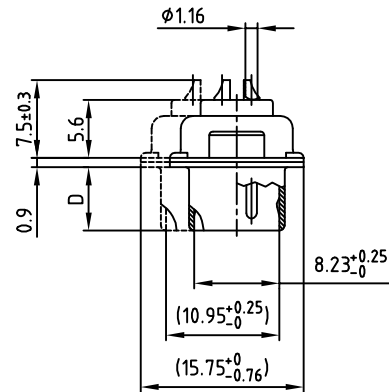
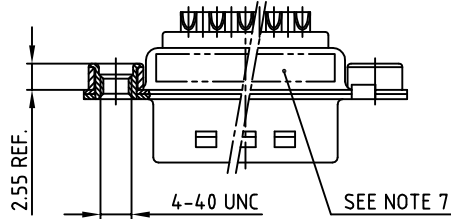
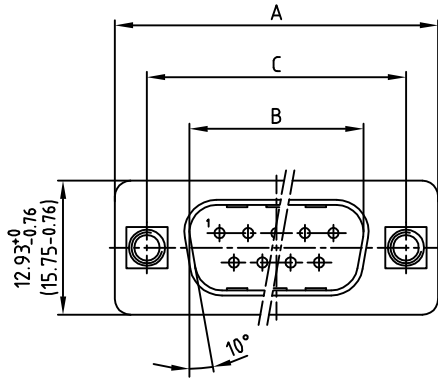

Dimensions in (---) = 50 pos.

NOTES:

- METALSHELLS: STEEL; min. 320µin TIN
- INSULATORS: PBT GF UL 94 V-0, BLACK
- CONTACTS: COPPER ALLOY
PLATING: GOLD FLASH over NICKEL
SOLDER CUP ACCEPTS CABLE AWG 20
- THREADED INSERT: COPPER ALLOY; min. 200µin TIN over 80µin NICKEL
- COLLAR: COPPER ALLOY; min. 200µin TIN over 80µin NICKEL
- MAXIMUM TORQUE VALUE FOR THREAD: 6in LBS
- CONNECTOR IS PART MARKED: PART-NO. CONEC ABC

Directive 2002/95/EC RoHS compliant

APPROVAL * FREIGABE * DEBLOCAGE * AUTORIZACION * APPROVAL	
CUSTOMER APPROVAL DATE:	
NAME:	TITLE:
COMPANY NAME:	
APPROVAL * FREIGABE * DEBLOCAGE * AUTORIZACION * APPROVAL	

THIS DRAWING MAY NOT BE COPIED OR REPRODUCED IN ANY WAY, AND MAY NOT BE PASSED ON TO A THIRD PARTY, WITHOUT WRITTEN PERMISSION. OWNERSHIP AND COPYRIGHT OF CONEC GmbH DO NOT ALTER CAD DRAWING BY HAND

rev.	description	date	name
a	Origin		

tolerance		 dim. in mm
2006	date	
drawn	06.02.	name
appd.	06.02.	Mickenbecker
norm	DIN 41652	
d-old		

scale:	2:1	
material:	SEE NOTES	
title:	D-SUB MALE 9-50pos. SOLDER CUP with threaded insert	
dwg no:	AutoCAD 2004	DIN-A
	16K1A1739	3
		sh: 1/1
part no:	SEE TABLE	