

FEATURES

- Radial Format
- Up to 1.8A IDC
- 10µH to 68mH
- Low DC Resistance
- Miniature Size
- PCB Mounting
- MIL-I-23053/5 Class III Slewing
- Fully Tinned Leads
- Supplied in Packs of 20
- Custom Parts Available

DESCRIPTION

The 1700 Series is a general-purpose range of inductors suitable for low to medium current applications. Their small footprint makes them ideal for high-density applications where a chip inductor will not cope with the power requirement.

SELECTION GUIDE

Order Code	Inductance ±10% (at 1kHz) µH	DC Resistance Ω MAX	DC Current Continuous A MAX	Nominal Q at f kHz		Nominal Self Resonant Frequency MHz
				Q	f	
17103	10.0	0.05	1.80	40	1000	21.2
17153	15.0	0.06	1.50	30	500	19.4
17223	22.0	0.08	1.20	30	500	17.0
17333	33.0	0.13	1.00	25	500	11.4
17473	47.0	0.20	0.86	25	500	10.9
17683	68.0	0.26	0.85	70	100	10.6
17104	100.0	0.35	0.74	65	100	8.9
17154	150.0	0.49	0.58	80	100	6.2
17224	220.0	0.75	0.48	90	100	5.4
17334	330.0	1.10	0.42	95	100	4.5
17474	470.0	1.50	0.34	100	100	3.2
17684	680.0	2.40	0.28	105	100	3.0
17105	1.0mH	3.30	0.19	120	100	2.5
17155	1.5mH	5.90	0.15	130	100	2.1
17225	2.2mH	7.80	0.12	130	50	1.9
17335	3.3mH	9.1	0.11	125	150	1.2
17475	4.7mH	12.0	0.09	130	150	0.95
17685	6.8mH	20.0	0.08	135	150	0.85
17106	10.0mH	34.0	0.07	140	150	0.62
17156	15.0mH	45.0	0.06	145	150	0.51
17226	22.0mH	75.0	0.05	100	50	0.34
17336	33.0mH	100.0	0.04	90	50	0.28
17476	47.0mH	140.0	0.03	80	50	0.25
17686	68.0mH	220.0	0.02	70	50	0.20

TYPICAL CORE CHARACTERISTICS

Inductance Temperature Coefficient	Resistance Temperature Coefficient	Curie Temperature T _C	Saturation Flux B _{SAT}
350ppm	3900ppm	190°C	325mT

ABSOLUTE MAXIMUM RATINGS

Operating free air temperature range	0°C to 70°C
Storage temperature range	-40°C to 125°C

MECHANICAL DIMENSIONS

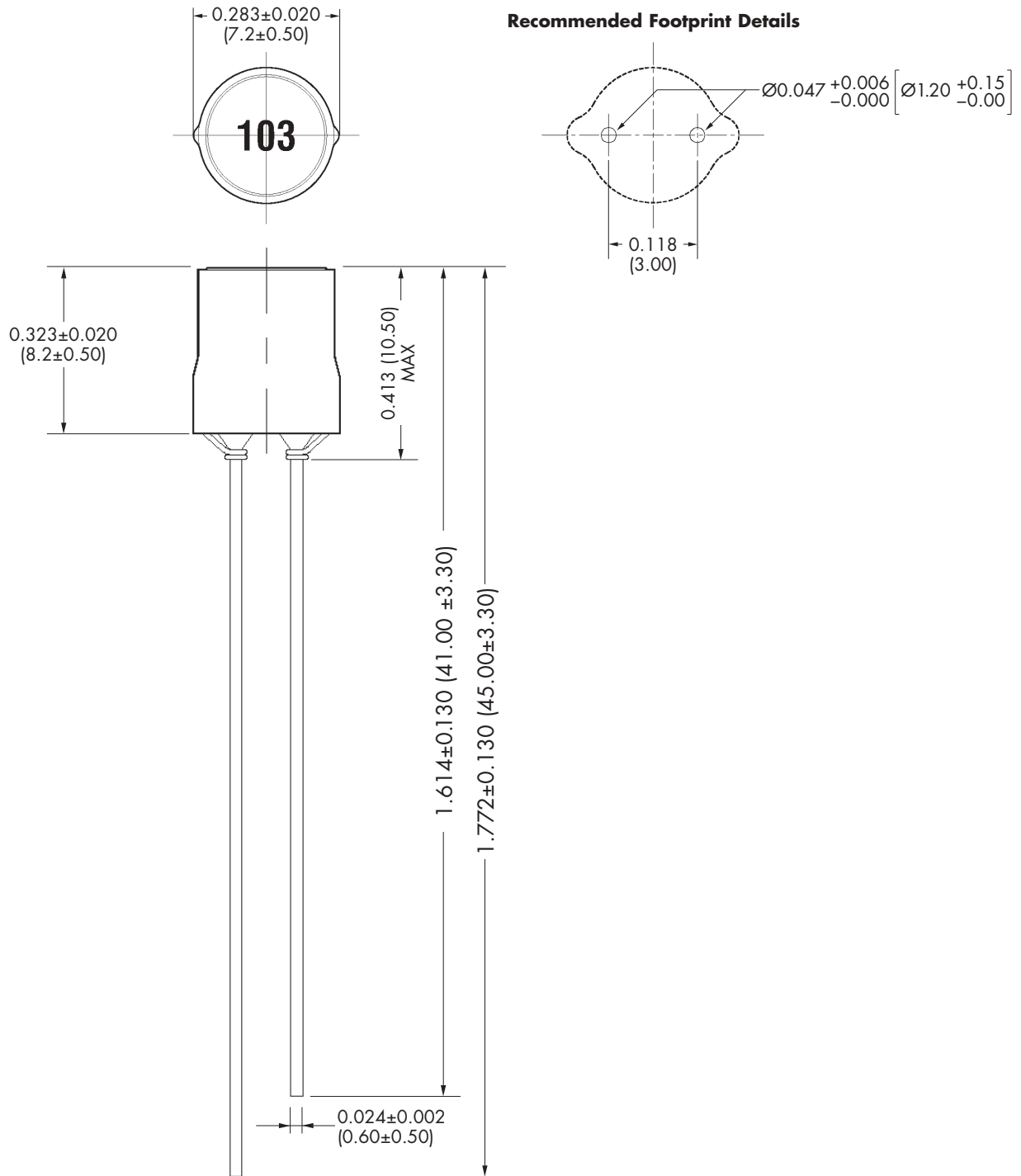

All dimensions in mm XX.X ± 0.50, XX.XX ± 0.25

C&D Technologies Inc. reserve the right to alter or improve the specification, internal design or manufacturing process at any time, without notice. Please check with your supplier or visit our web site to ensure that you have the current and complete specification for your product before use.

© C&D Technologies (NCL) Limited 2004

NMP 1700.3

No part of this publication may be copied, transmitted or stored in a retrieval system or reproduced in any way including, but not limited to, photography, photocopy, magnetic or other recording means, without prior written permission from C&D Technologies Inc.

Instructions for use are available from: www.cdpoweronline.com

C&D Technologies (NCL) Ltd
Tanners Drive, Blakelands North
Milton Keynes MK14 5BU, England
Tel: +44 (0)1908 615232
Fax: +44 (0)1908 617545
email: info@cdtechno-ncl.com

www.cdpoweronline.com

C&D Technologies Inc.
3400 E Britannia Drive, Tucson,
Arizona 85706, USA
Tel: +1 (800) 547-2537
Fax: +1 (520) 741-4598
email: sales@cdtechno.com