

## 35V 1A LED driver with internal switch

### GENERAL DESCRIPTION

The CL6807 is a continuous mode inductive step-down converter, designed for driving single or multiple series connected LEDs efficiently from a voltage source higher than the LED voltage. The device operates from an input supply between 6V and 35V and provides an externally adjustable output current of up to 1A. Depending upon supply voltage and external components, this can provide up to 35 watts of output power.

### FEATURES

- ◆ Simple low parts count
- ◆ Wide input voltage range: 6V to 35V
- ◆ Up to 1A output current
- ◆ Single pin on/off and brightness control using DC voltage or PWM
- ◆ Typical 5% output current accuracy
- ◆ Inherent open-circuit LED protection
- ◆ High efficiency (up to 95%)
- ◆ High-Side Current Sense
- ◆ Soft-start
- ◆ Available in SOT89-5 packages

### APPLICATIONS

- ◆ Low voltage halogen replacement LEDs
- ◆ Automotive lighting
- ◆ Low voltage industrial lighting
- ◆ LED back-up lighting
- ◆ Illuminated signs

### PIN ASSIGNMENT

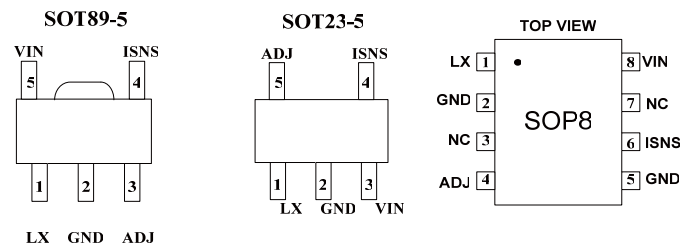

### TYPICAL APPLICATIONS PIN DESCRIPTIONS

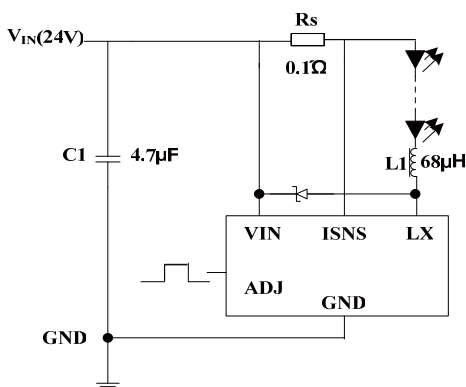

SOP8	PIN NO.		PIN NAMES	DESCRIPTION
	SOT89-5	SOT23-5		
1	1	1	LX	Drain of the internal N-Ch MOSFET switch.
2, 5	2	2	GND	Ground.
4	3	5	ADJ	Multi-function On/Off and brightness control pin: • Leave floating for normal operation ( $V_{ADJ}$ was internal pulled up). average output current $I_{OUTnom} = 0.1/R_S$ • Drive to voltage below 0.4V to turn off output current • Drive with DC voltage ( $0.5V < V_{ADJ} < 2.5V$ ) to adjust output current from 0% to 100% of $I_{OUTnom}$ • Drive with PWM signal from open-collector or open-drain transistor, to adjust output current. Adjustment range 25% to 100% of $I_{OUTnom}$ for $f > 10kHz$ and 1% to 100% of $I_{OUTnom}$ for $f < 500Hz$ • Connect a capacitor from this pin to ground to increase soft-start time.
6	4	4	ISNS	Current sense input
8	5	3	VIN	Input Supply Pin. Must be locally bypassed

### ABSOLUTE MAXIMUM RATINGS

SYMBOL	ITEMS	VALUE	UNIT
$V_{IN}$	Supply Voltage	-0.3~35	V
SW	Drain of the internal power switch	-0.3~35	V
ISNS	Current sense input (Respect to $V_{IN}$ )	+0.3~(-5.0)	V
ADJ	Logic level dimming input	-0.3~6	V
$P_{DMAX}$	Power Dissipation (Note 2)	Internally Limited	W
$P_{TR}$	Thermal Resistance, SOT89-5 $\theta_{JA}$	45	$^{\circ}C/W$
$T_J$	Operation Junction Temperature Range	-40 to 150	$^{\circ}C$
$T_{STG}$	Storage Temperature	-55 to 150	$^{\circ}C$
	ESD Susceptibility (Note 3)	2	kV

### RECOMMENDED OPERATING RANGE

SYMBOL	ITEMS	VALUE	UNIT
$V_{IN}$	VDD Supply Voltage	0 ~ 35	V
$T_{OPT}$	Operating Temperature	-40 to +85	$^{\circ}C$

performance.

**Note 2:** The maximum power dissipation must be derated at elevated temperatures and is dictated by  $T_{JMAX}$ ,  $\theta_{JA}$ , and the ambient temperature  $T_A$ . The maximum allowable power dissipation is  $P_{DMAX} = (T_{JMAX} - T_A) / \theta_{JA}$ , or the number given in Absolute Maximum Ratings, whichever is lower.

**Note 3:** Human body model, 100pF discharged through a 1.5kΩ resistor.

## ELECTRICAL CHARACTERISTICS (Note 4, 5)

The following specifications apply for  $V_{IN}=24V$ ,  $T_A=25^\circ C$ , unless specified otherwise.

Symbol	Parameter	Conditions	Min.	Typ.	Max.	Unit
$V_{IN}$	Input Voltage		6		35	V
$F_{SW}$	Max. Switching Frequency				1	MHz
$V_{ISNS}$	Mean current sense threshold voltage	$V_{IN}-V_{ISNS}$	95	100	105	mV
$V_{ISNS\_HYS}$	Sense threshold hysteresis			±15		%
	Optional			±30		%
$I_{ISNS}$	ISNS Pin Input Current	$V_{IN}-V_{ISNS}=100mV$		8		μA
$I_{OFF}$	Quiescent supply current with output off			75		μA
$I_{OP}$	Quiescent supply current with output switching			1.8		mA
$V_{ADJ\_H}$	ADJ input voltage High		2.5			V
$V_{ADJ\_L}$	ADJ input voltage Low				0.5	V
$V_{ADJ\_DC}$	DC brightness control		0.5		2.5	V
$f_{ADJ}$	Max. ADJ Frequency				20	kHz
$D_{PWM\_LF}$	Duty cycle range of low frequency dimming	$f_{ADJ} > 100Hz$	0.02%		1	
	Brightness control range				5000:1	
$D_{PWM\_HF}$	Duty cycle range of high frequency dimming	$f_{ADJ} < 20KHz$	4%		1	
	Brightness control range				25:1	
$I_{ADJ\_H}$	ADJ input leakage high	$V_{ADJ} = 5V$	-1		+1	μA
$I_{ADJ\_L}$	Duty cycle range of high frequency dimming	$V_{ADJ} = 0$	0.2		1	
$R_{LX}$	LX On Resistance	$I_{LX}=1A$		0.5		Ω
$I_{LXmean}$	Continuous LX Current				1	A
$I_{LEAK}$	LX Leakage Current			0.5	5	μA

**Note 4:** Typical parameters are measured at 25°C and represent the parametric norm.

**Note 5:** Datasheet min/max specification limits are guaranteed by design, test, or statistical analysis.

## SIMPLIFIED BLOCK DIAGRAM

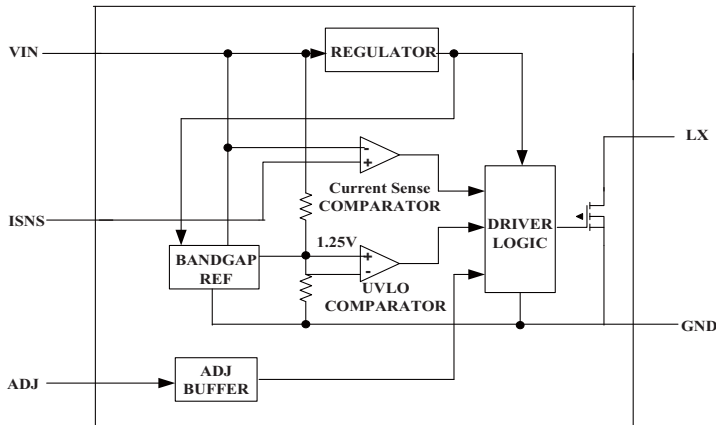

## OPERATION DESCRIPTION

The CL6807 are step-down, constant current, high-brightness LED (HB LED) drivers. These devices operate from a 6V to 35V input voltage range and provide up to 1A sourcing LEDs. A high-side current-sense resistor sets the output current and a dedicated PWM dimming input (ADJ) allows for a wide range of independent pulsed dimming. The high-side current-sensing scheme and on-board current-setting circuitry minimize the number of external components while delivering LED current with a ±5% accuracy (below 30V input), using a 1% sense resistor. The device, in conjunction with the coil (L1) and current sense resistor (RS), forms a self-oscillating continuous-mode buck converter.

When input voltage  $V_{IN}$  is first applied, the initial current in L1 and RS is zero and there is no output from the current sense circuit. Under this condition, the output of CS comparator is high. This turns MN on and switches the LX pin low, causing current to flow from  $V_{IN}$  to ground, via  $R_S$ , L1 and the LED(s). The current rises at a rate determined by  $V_{IN}$  and L1 to produce a voltage ramp ( $V_{ISNS}$ ) across  $R_S$ . When  $(V_{IN}-V_{ISNS}) > 115mV$ , the output of CS comparator switches low and MN turns off. The current flowing on the RS decreases at another rate. When  $(V_{IN}-V_{ISNS}) < 85mV$ , the MN turns on again and the mean current on the LED is determined by  $((85 + 115)/2 mV) / R_S = 100mV / R_S$ .

The high-side current-sensing scheme and on-board current-setting circuitry minimize the number of external components while delivering LED current with ±5% accuracy, using a 1% sense resistor.

The CL6807 allow dimming with a PWM signal at the ADJ input. A logic level below 0.3V at ADJ forces CL6807 to turn off the LED and the logic level at ADJ must be at least 2.5V to turn on the

LED current.

The ADJ pin can be driven by an external dc voltage ( $V_{ADJ}$ ) to adjust the output current to a value below the nominal average value defined by  $R_S$ .

High luminance LEDs often need to be supplied with a temperature compensated current in order to maintain stable and reliable operation at all drive levels. The LEDs are usually mounted remotely from the device so, for this reason, the temperature coefficients of the internal circuits for the CL6807 have been optimized to minimize the change in output current when no compensation is employed. If output current compensation is required, it is possible to use an external temperature sensing network - normally using Negative Temperature Coefficient (NTC) thermistors and/or diodes, mounted very close to the LED(s). The output of the sensing network can be used to drive the ADJ pin in order to reduce output current with increasing temperature.

## 5V Regulator

VCC is the output of a 5V regulator capable of sourcing 10mA. VCC was bypassed to GND with internal capacitor.

## ADJ Input

The CL6807 allow dimming with a PWM signal at the ADJ input. A logic level below 0.5V at ADJ turns off the LED current. To turn the LED current on, the logic level at ADJ must be at least 2.5V.

## APPLICATION DESCRIPTION

參考資料

### Selecting $R_{SENSE}$ to Set the LED Current

The CL6807 feature a programmable LED current using a resistor connected between  $V_{IN}$  and ISNS. Use the following equation to calculate the sense resistor:

$$I_{out} = \frac{0.1 \times V_{ADJ} (0.5V \leq V_{ADJ} \leq 2.5V)}{2.5 \times R_S}$$

### Current Regulator Operation

The CL6807 regulate the LED output current using an input comparator with hysteresis (Figure 1). As the current through the inductor ramps up and the voltage across the sense resistor reaches the upper threshold, turns off the internal MOSFET. The MOSFET turns on again when the inductor current ramps down through the freewheeling diode until the voltage across the sense resistor equals the lower threshold. Use the following equation to determine the operating frequency:

$$f_{sw} = \frac{(V_{IN} - n \times V_{LED}) \times n \times V_{LED} \times R_{SENSE}}{V_{IN} \times \Delta V \times L}$$

where  $n$  = number of LEDs,  $V_{LED}$  = forward voltage drop of one LED, and  $\Delta V = (V_{SNS\_HI} - V_{SNS\_LO})$ .

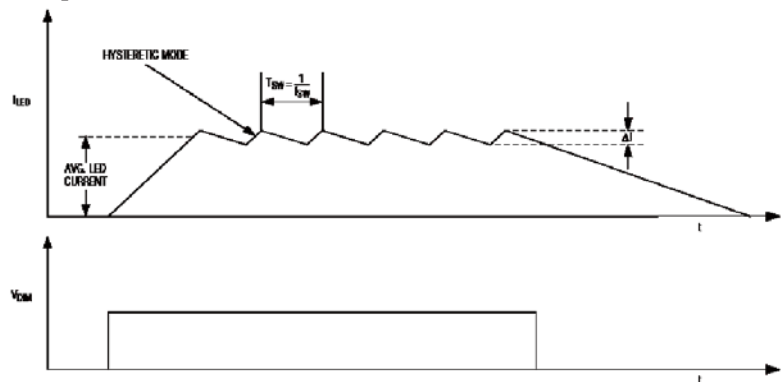

Figure 1. Current Regulator Operation

### Freewheeling Diode Selection

The forward voltage of the freewheeling diode should be as low as possible for better efficiency. A Schottky diode is a good choice as long as the breakdown voltage is high enough to withstand the maximum operating voltage. The forward current rating of the diode must be at least equal to the maximum LED current.

### LED Current Ripple

The LED current ripple is equal to the inductor current ripple. In cases when a lower LED current ripple is needed, a capacitor can be placed across the LED terminals.

### PCB Layout Guidelines

Careful PCB layout is critical to achieve low switching losses and stable operation. Use a multilayer board whenever possible for better noise immunity. Minimize ground noise by connecting high-current ground returns, the input bypass-capacitor ground lead, and the output-filter ground lead to a single point (star ground configuration). In normal operation, there are two power loops. One is formed when the internal MOSFET is on and the high current flows through  $IN-R_{SENSE}-LEDs-Inductor-MOSFET-GND$ . The other loop is formed when the internal MOSFET is off when the high current circulates through  $R_{SENSE}-LEDs-Inductor-freewheeling diode$ . To minimize noise interaction, each loop area should be as small as possible. Place  $R_{SENSE}$  as close as possible to the input filter and  $V_{IN}$ . For better noise immunity, a Kelvin connection is strongly recommended between ISNS and  $R_{SENSE}$ . Connect the exposed paddle to a large-area ground plane for improved power dissipation.

### PACKAGE INFORMATION SOT89-5 Package

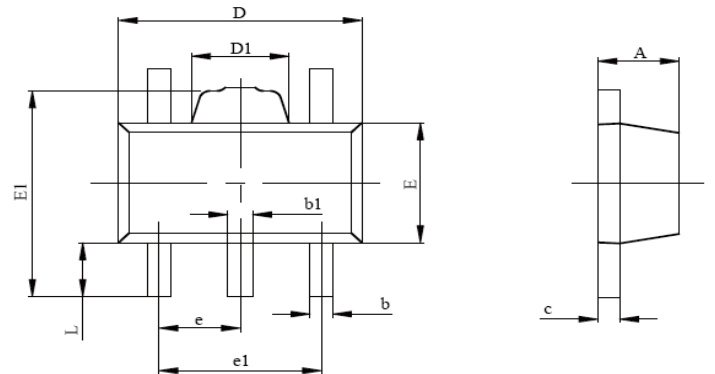

Symbol	Millimeters	
	Min	Max
A	1.400	1.600
b	0.320	0.520
b1	0.360	0.560
c	0.350	0.440
D	4.400	4.600
D1	1.400	1.800
E	2.300	2.600
E1	3.940	4.250
e	1500 TYP	
e1	2.900	3.100
L	0.900	1.100