

## TVSS5VCES-02GP

### 1. Description

The TVSS5VCES-02GP is designed to protect voltage sensitive components from damage or latch-up due to ESD. Excellent clamping capability, low leakage, and fast response time provide best in class protection on designs that are exposed to ESD for board level. Because of its small size and bi-directional design, it is ideal for use in cellular phones, MP3 players, and portable applications that require audio line protection.

### 2. Features

- IEC 61000-4-2 Level 4 ESD Protection
  - ±25kV Contact Discharge
  - ±25kV Air Discharge
- 80W Peak pulse Power (8/20us)
- Low clamping voltage
- Working voltage: 5V
- Low leakage current
- RoHS compliant
- Protecting one bi-directional lines
- Junction capacitance: 15pF Typ.

### 3. Applications

- Cellular handsets and accessories
- Portable digital assistants
- Notebooks & handhelds
- Digital cameras
- MP3 players
- Peripherals

### 4. Ordering Information

| Part Number    | Package | Marking | Material     | Packing     | Quantity per reel | Flammability Rating | Reel Size |
|----------------|---------|---------|--------------|-------------|-------------------|---------------------|-----------|
| TVSS5VCES-02GP | SOD-523 | DT      | Halogen free | Tape & Reel | 3,000 PCS         | UL 94V-0            | 7 inches  |

Table-1 Ordering information

## 5. Pin Configuration and Functions

| Pin | Name | Description   | Outline  | Circuit Diagram   |
|-----|------|---------------|--|---|
| 1   | IO1  | Connect to IO |  |  |
| 2   | IO2  | Connect to IO |  |   |

Table-2 Pin configuration

## 6. Specification

### 6.1. Absolute Maximum rating

Over operating free-air temperature range (unless otherwise noted)

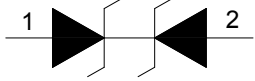
| Parameters                                 | Symbol           | Min. | Max. | Unit |
|--|------------------|------|------|------|
| Peak pulse power (tp=8/20us)@25°C          | P <sub>pk</sub>  | -    | 80   | W    |
| Peak pulse current (tp=8/20us)@25°C        | I <sub>PP</sub>  |      | 8    | A    |
| ESD (IEC61000-4-2 air discharge) @25°C     | V <sub>ESD</sub> | -    | ±25  | kV   |
| ESD (IEC61000-4-2 contact discharge) @25°C | V <sub>ESD</sub> | -    | ±25  | kV   |
| Junction temperature                       | T <sub>J</sub>   | -    | 150  | °C   |
| Operating temperature                      | T <sub>OP</sub>  | -40  | 125  | °C   |
| Storage temperature                        | T <sub>STG</sub> | -55  | 150  | °C   |
| Lead temperature                           | T <sub>L</sub>   | -    | 260  | °C   |

Table-3 Absolute Maximum rating

## 6.2. Electrical Characteristics

At TA = 25°C unless otherwise noted

| Parameter                 | Symbol    | Conditions                      | Min. | Typ. | Max. | Units   |
|---------------------------|-----------|---------------------------------|------|------|------|---------|
| Reverse Stand-off Voltage | $V_{RWM}$ |                                 |      |      | 5    | V       |
| Reverse Breakdown Voltage | $V_{BR}$  | $I_T=1mA$                       | 5.8  |      |      | V       |
| Reverse Leakage Current   | $I_R$     | $V_{RWM}=5V$                    |      |      | 1    | $\mu A$ |
| Clamping Voltage          | $V_C$     | $I_{PP}=1A$ ; $t_p=8/20\mu s$   |      | 6    |      | V       |
| Clamping Voltage          | $V_C$     | $I_{PP}=8A$ ; $t_p=8/20\mu s$   |      | 10   |      | V       |
| Junction Capacitance      | $C_J$     | I/O to GND; $V_R=0V$ ; $f=1MHz$ |      | 15   |      | pF      |

Table-4 Electrical Characteristics

| Symbol    | Parameters                          |
|-----------|-------------------------------------|
| $V_{RWM}$ | Peak Reverse Working Voltage        |
| $I_R$     | Reverse Leakage Current @ $V_{RWM}$ |
| $V_{BR}$  | Breakdown Voltage @ $I_T$           |
| $I_T$     | Test Current                        |
| $I_{PP}$  | Maximum Reverse Peak Pulse Current  |
| $V_C$     | Clamping Voltage @ $I_{PP}$         |

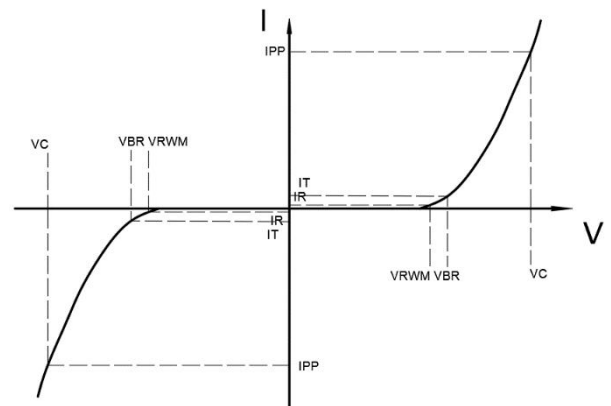

### 7. Typical Characteristic

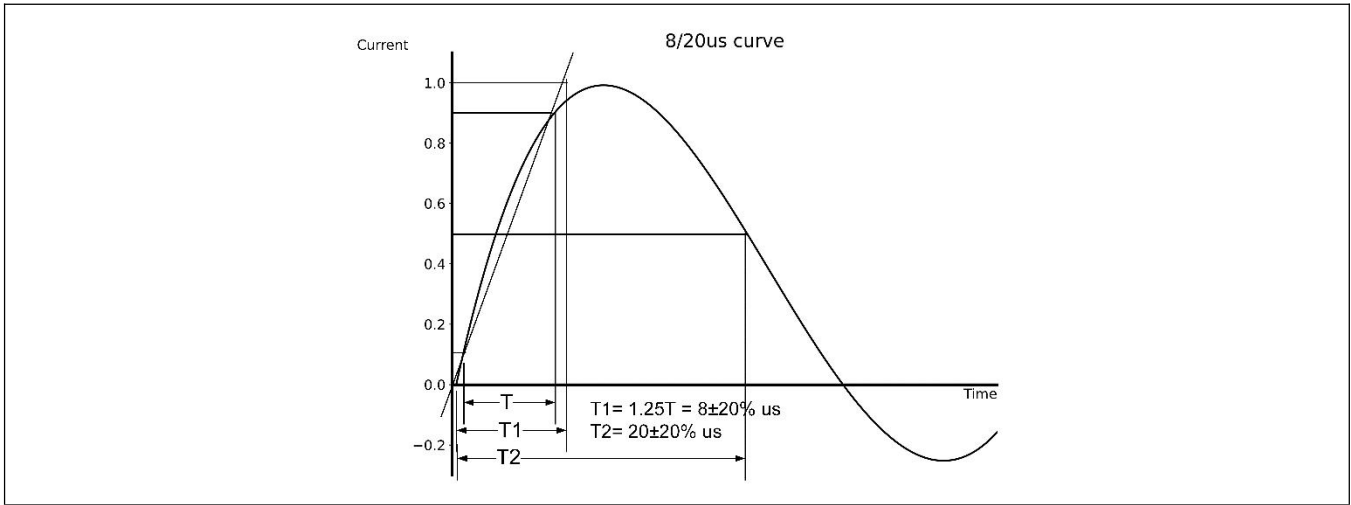

### 8. Typical Application

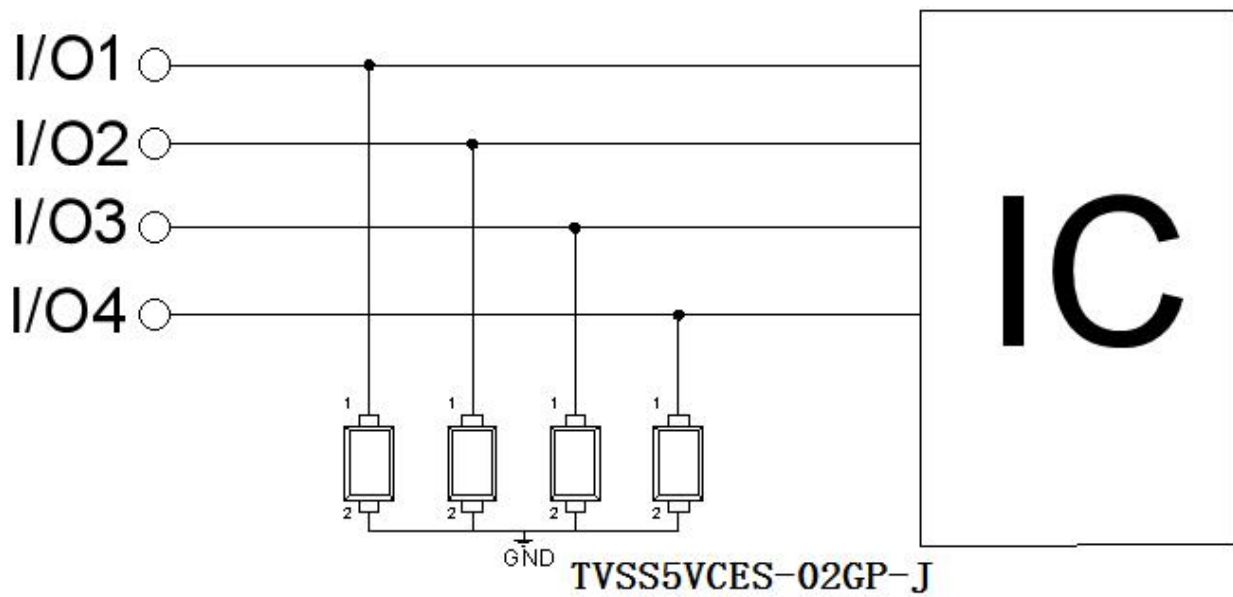

Typical Interface Application

9. Dimension

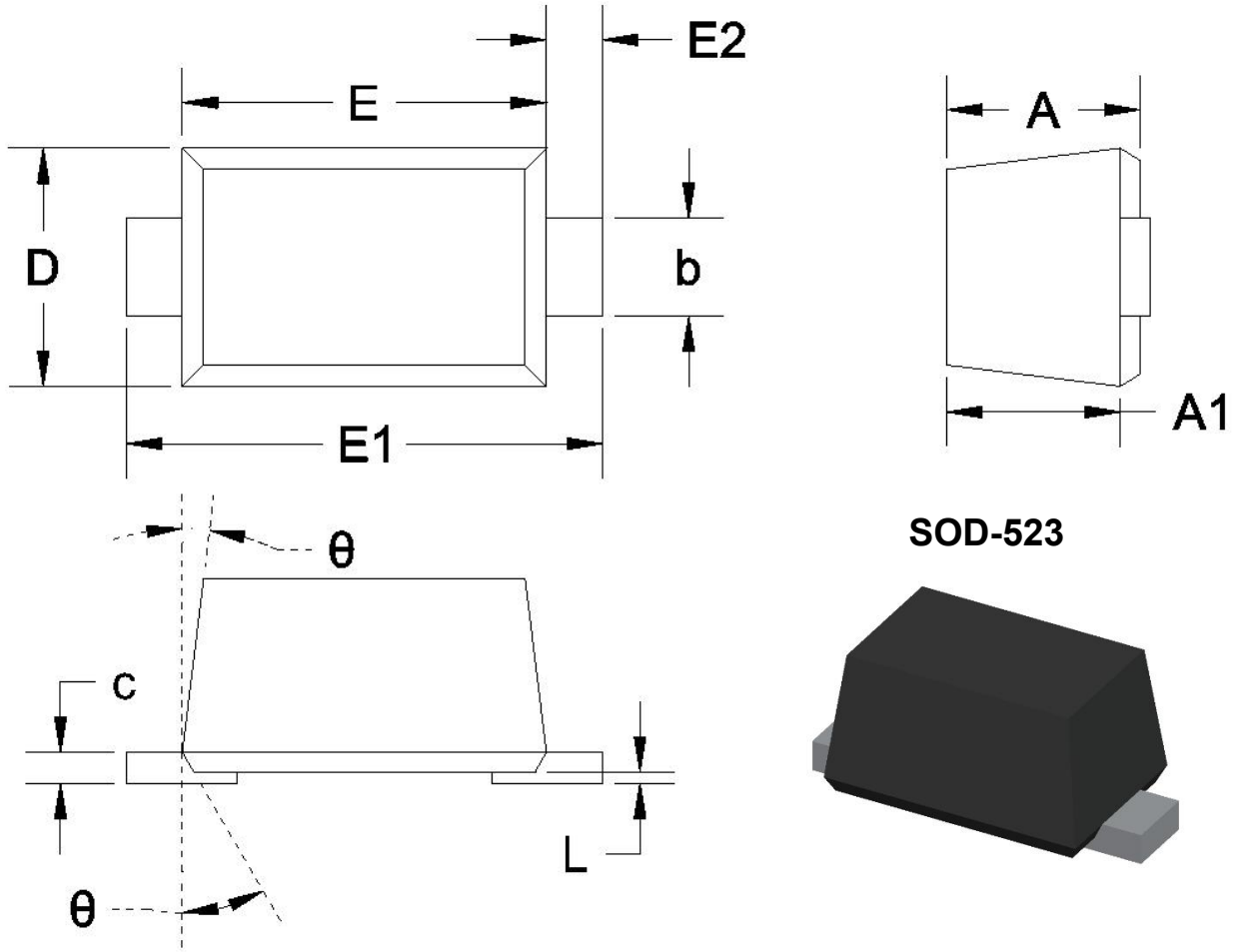

| Unit | A    | A1   | b    | c    | D    | E    | E1   | E2   | L    | θ    |
|------|------|------|------|------|------|------|------|------|------|------|
| Max. | 0.77 | 0.70 | 0.35 | 0.15 | 0.85 | 1.30 | 1.70 | 0.20 | 0.07 | 7°   |
| Min. | 0.51 | 0.50 | 0.25 | 0.08 | 0.75 | 1.10 | 1.50 | REF. | 0.01 | REF. |

Table-5 Product dimensions in millimeter

## 10. Recommended Land Pattern

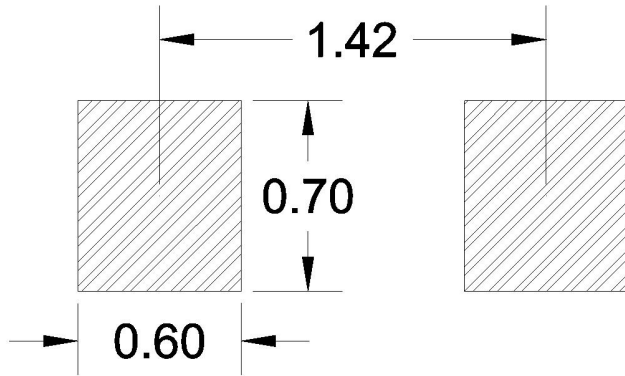

## Note:

1. Controlling dimension: in millimeters
2. General tolerance:  $\pm 0.05\text{mm}$
3. The pad layout is for reference only
4. Unit: mm