

DATE: _____

MESSRS. : _____

AGENT : _____

SPECIFICATION
OF
PYROELECTRIC PASSIVE
INFRARED SENSOR

MODEL NO. RE200B-P

PART NO. _____

PYROELECTRIC PASSIVE INFRARED SENSOR MODEL NO. RE200B-P	PAGE 1 / 6	DRAWING NO.	REV : A
	NIPPON CERAMIC CO., LTD.		
APPROVED BY	CHECKED BY	DRAWN BY	

SCOPE

THIS SPECIFICATION DESCRIBES A PYROELECTRIC PASSIVE INFRARED SENSOR SUPPLIED BY NIPPON CERAMIC CO., LTD.

TYPE OF SENSOR

BALANCED DIFFERENTIAL (SERIES OPPOSED TYPE.)

PHYSICAL CONFIGURATION

- 1) PACKAGE : TO-5 METAL CAN WITH DIMENSIONS SHOWN IN FIGURE 1-C (NICKEL-PLATED)
- 2) ELEMENT GEOMETRY : TWO SENSITIVE AREAS 2.0 mm LONG, 1.0 mm WIDE AND SPACED 1.0 mm APART.
- 3) ELEMENT ORIENTATION : SEE FIGURE 1-B
- 4) LEAD CONFIGURATION : SEE FIGURE 1-C, 1-D

ELECTRICAL CHARACTERISTICS (AT 25 ± 5 °C)

- 1) CIRCUIT CONFIGURATION : THREE-TERMINAL SENSOR WITH SOURCE FOLLOWER
SEE FIGURE 2
- 2) OPERATING VOLTAGE : 3 ~ 10 V DC (R_s : 47K Ω)
- 3) SOURCE VOLTAGE : 0.3 ~ 1.5 V (V_D : 5V, R_s : 47K Ω)
- 4) SIGNAL OUTPUT : MIN. 2.5 V_{p-p} (TYP. 4.0 V_{p-p})

SIGNAL OUTPUT IS MEASURED AT CHOPPER FREQUENCY OF 1 Hz WHEN CONNECTED TO THE AMPLIFIER OF GAIN 72.5 dB (AT 1 Hz) AND SUBMITTED TO THE EMISSION OF INFRARED ENERGY OF 13 μ W/cm² FROM 420 K BLACK BODY.
SEE FIGURE 3

- 5) NOISE OUTPUT : MAX. 250 mV_{p-p} (TYP. 90 mV_{p-p})

NOISE OUTPUT SHALL BE MEASURED FOR 20 SECONDS WHEN CONNECTED TO THE AMPLIFIER OF GAIN 72.5 dB AND SHUT OUT FROM INFRARED ENERGY.
SEE FIGURE 3

MODEL NO. : RE200B-P

PART NO. :

PAGE
2 / 6

DRAWING NO.

REV :
A

 NIPPON CERAMIC CO., LTD.

6) BALANCE OUTPUT : MAX. 15 %

$$\left[\frac{BO}{|SA+SB|} \right] \leq 0.15$$

BO : BALANCE OUTPUT

SA : SIGNAL OUTPUT ON ELEMENT A

SB : SIGNAL OUTPUT ON ELEMENT B

BALANCE OUTPUT IS MEASURED AT CHOPPER FREQUENCY OF 1 Hz WHEN CONNECTED TO THE AMPLIFIER OF GAIN 72.5 dB (AT 1 Hz) AND SUBMITTED TO THE EMISSION OF INFRARED ENERGY OF $13 \mu W/cm^2$ FROM 420 K BLACK BODY.
SEE FIGURE 3

7) FREQUENCY RESPONSE : 0.3 Hz TO 3.0 Hz / ± 10 dB

OPTICAL CHARACTERISTICS

- 1) FIELD OF VIEW : 138° FROM CENTER OF ELEMENT ON AXIS X
: 125° FROM CENTER OF ELEMENT ON AXIS Y
: SEE FIGURE 1-A
- 2) FILTER SUBSTRATE : SILICON
- 3) CUT ON (5 %T ABS) : $5.0 \pm 0.5 \mu m$
- 4) TRANSMISSION : ≥ 70 % AVERAGE 7~14 μm

ENVIRONMENTAL REQUIREMENTS

- 1) OPERATING TEMPERATURE : -30 °C TO +70 °C
- 2) STORAGE TEMPERATURE : -40 °C TO +80 °C
- 3) RELATIVE HUMIDITY :
THE SENSOR SHALL OPERATE WITHOUT INCREASE IN NOISE OUTPUT WHEN EXPOSED TO 90 ~ 95 % RH AT 30 °C CONTINUOUSLY.
- 4) HERMETIC SEAL :
THE SENSOR SHALL BE SEALED TO WITHSTAND A VACUUM OF 21.28 kPa.

RoHS COMPLIANCE

THE SENSOR DOES NOT CONTAIN LEAD, MERCURY, CADMIUM, HEXAVALENT CHROMIUM, POLYBROMINATED BIPHENYLS (PBB) OR POLYBROMINATED DIPHENYL ETHERS (PBDE) IN MORE THAN THE PERCENTAGES SPECIFIED BY EU DIRECTIVE 2002/95/EC, EXCEPT EXEMPTIONS STATED IN EU DIRECTIVE 2002/95/EC ANNEX.

MODEL NO. : RE200B-P

PART NO. :

PAGE
3 / 6

DRAWING NO.

REV :
A

 NIPPON CERAMIC CO., LTD.

CONFIGURATION (FIGURE 1)

FIELD OF VIEW
(FIGURE 1-A)

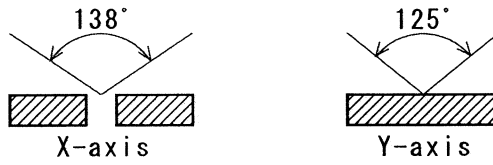

TOP VIEW
(FIGURE 1-B)

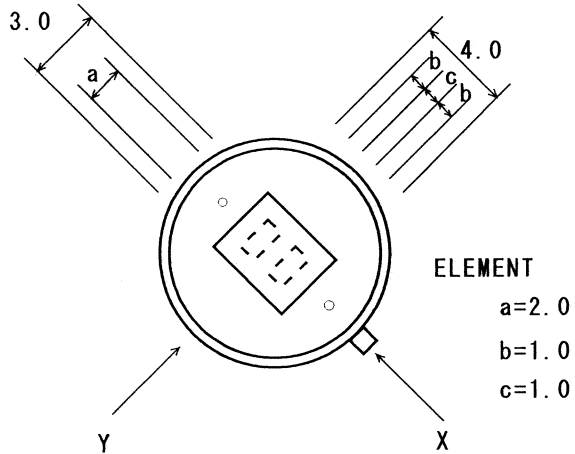

SIDE VIEW
(FIGURE 1-C)

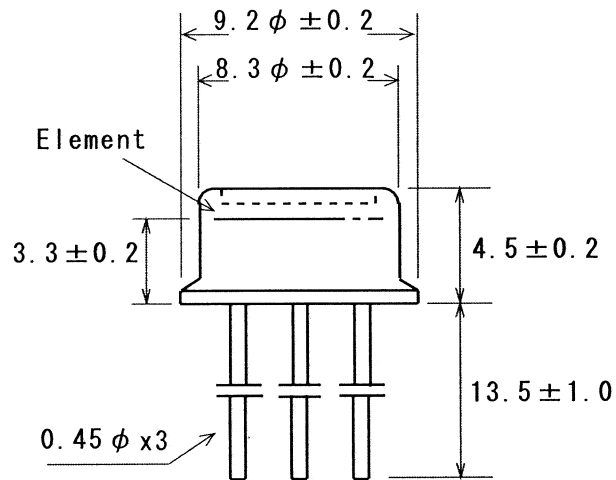

BASE VIEW
(FIGURE 1-D)

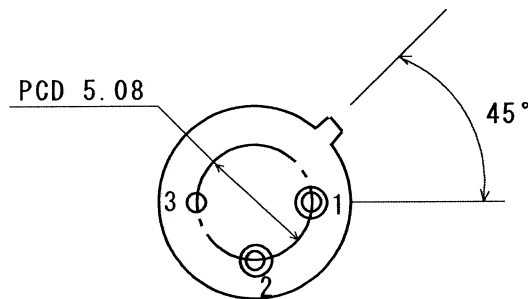

- 1: DRAIN
- 2: SOURCE
- 3: GROUND

UNIT : mm

MODEL NO. : RE200B-P

PAGE
4 / 6

DRAWING NO.

REV :
A

PART NO. :

© NIPPON CERAMIC CO., LTD.

※ NOTES

1. DESIGN RESTRICTIONS/PRECAUTIONS

IF USED FOR OUTDOOR APPLICATIONS, BE SURE TO APPLY SUITABLE SUPPLEMENTARY OPTICAL FILTER AND DRIP-PROOF, ANTI-DEW CONSTRUCTION. THIS SENSOR IS DESIGNED FOR INDOOR USE.

IN CASES WHERE SECONDARY ACCIDENTS DUE TO OPERATION FAILURE OR MALFUNCTIONS CAN BE ANTICIPATED, ADD A FAIL SAFE FUNCTION TO THE DESIGN.

2. USAGE RESTRICTIONS/PRECAUTIONS

TO PREVENT SENSOR MALFUNCTIONS, OPERATIONAL FAILURE OR ANY DETERIORATION OF ITS CHARACTERISTICS, DO NOT USE THIS SENSOR IN THE FOLLOWING, OR SIMILAR, CONDITIONS.

- A. IN RAPID ENVIRONMENTAL TEMPERATURE CHANGES.
- B. IN STRONG SHOCK OR VIBRATION.
- C. IN A PLACE WHERE THERE ARE OBSTRUCTING MATERIALS (GLASS, FOG, ETC.) THROUGH WHICH INFRARED RAYS CANNOT PASS WITHIN DETECTION AREA.
- D. IN FLUID, CORROSIVE GASES AND SEA BREEZE.
- E. CONTINUAL USE IN HIGH HUMIDITY ATMOSPHERE.
- F. EXPOSED TO DIRECT SUN LIGHT OR HEADLIGHTS OF AUTOMOBILES.
- G. EXPOSED TO DIRECT WIND FROM A HEATER OR AIR CONDITIONER.

3. ASSEMBLY RESTRICTIONS/PRECAUTIONS

SOLDERING -----

- A. USE SOLDERING IRONS WHEN SOLDERING.
- B. AVOID KEEPING PINS OF THIS SENSOR HOT FOR A LONG TIME AS EXCESSIVE HEAT MAY CAUSE DETERIORATION OF ITS QUALITY. (E. G. WITHIN 5 SEC. AT 350 °C)

WASHING -----

- A. BE SURE TO WASH OUT ALL FLUX AFTER SOLDERING AS REMAINDER MAY CAUSE MALFUNCTIONS.
- B. USE A BRUSH WHEN WASHING. WASHING WITH AN ULTRASONIC CLEANER MAY CAUSE OPERATIONAL FAILURE.

4. HANDLING AND STORAGE RESTRICTIONS/PRECAUTIONS

TO PREVENT SENSOR MALFUNCTIONS, OPERATIONAL FAILURE, APPEARANCE DAMAGE OR ANY DETERIORATION OF ITS CHARACTERISTICS, DO NOT EXPOSE THIS SENSOR TO THE FOLLOWING OR SIMILAR, HANDLING AND STORAGE CONDITIONS.

- A. VIBRATION FOR A LONG TIME.
- B. STRONG SHOCK.
- C. STATIC ELECTRICITY OR STRONG ELECTROMAGNETIC WAVES.
- D. HIGH TEMPERATURE AND HUMIDITY FOR A LONG TIME.
- E. CORROSIVE GASES OR SEA BREEZE.
- F. DIRTY AND DUSTY ENVIRONMENTS THAT MAY CONTAMINATE THE OPTICAL WINDOW.

SENSOR TROUBLES RESULTING FROM MISUSE, INAPPROPRIATE HANDLING OR STORAGE ARE NOT THE MANUFACTURER'S RESPONSIBILITY.

MODEL NO. : RE200B-P

PART NO. :

PAGE
6 / 6

DRAWING NO.

REV :
A

☉ NIPPON CERAMIC CO., LTD.