



浩畅半导体
www.szhaochang.cn

A1015 TRANSISTOR (PNP)

SOT-23 Plastic-Encapsulate Transistors

产
品
规
格
书

承
认
书

客户确认：

公司签章：

部门

工程部

品保部

采购部

签名

日期



SOT-23 Plastic-Encapsulate Transistors

A1015 TRANSISTOR (PNP)

FEATURES

- High voltage and high current
- Excellent h_{FE} Linearity
- Low noise
- Complementary to C1815

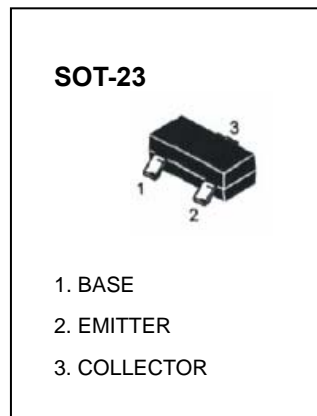

MARKING: BA

MAXIMUM RATINGS ($T_A=25^{\circ}\text{C}$ unless otherwise noted)

Symbol Para	meter	Value	Units
V_{CBO}	Collector-Base Voltage	-50	V
V_{CEO}	Collector-Emitter Voltage	-50	V
V_{EBO}	Emitter-Base Voltage	-5	V
I_C	Collector Current -Continuous	150	mA
P_C	Collector Power Dissipation	200	mW
T_J	Junction Temperature	125	$^{\circ}\text{C}$
T_{stg}	Storage Temperature	-55-125	$^{\circ}\text{C}$

ELECTRICAL CHARACTERISTICS ($T_{amb}=25^{\circ}\text{C}$ unless otherwise specified)

Parameter	Symbol	Test conditions	MIN	TYP	MAX	UNIT
Collector-base breakdown voltage	$V_{(BR)CBO}$	$I_C = -100\mu\text{A}$, $I_E = 0$	-50			V
Collector-emitter breakdown voltage	$V_{(BR)CEO}$	$I_C = -0.1\text{mA}$, $I_B = 0$	-50			V
Emitter-base breakdown voltage	$V_{(BR)EBO}$	$I_E = -100\mu\text{A}$, $I_C = 0$	-5			V
Collector cut-off current	I_{CBO}	$V_{CB} = -50\text{V}$, $I_E = 0$			-0.1	μA
Collector cut-off current	I_{CEO}	$V_{CE} = -50\text{V}$, $I_B = 0$			-0.1	μA
Emitter cut-off current	I_{EBO}	$V_{EB} = -5\text{V}$, $I_C = 0$			-0.1	μA
DC current gain	h_{FE}	$V_{CE} = -6\text{V}$, $I_C = -2\text{mA}$	130		400	
Collector-emitter saturation voltage	$V_{CE(sat)}$	$I_C = -100\text{mA}$, $I_B = -10\text{mA}$			-0.3	V
Base-emitter saturation voltage	$V_{BE(sat)}$	$I_C = -100\text{mA}$, $I_B = -10\text{mA}$			-1.1	V
Transition frequency	f_T	$V_{CE} = -10\text{V}$, $I_C = -1\text{mA}$ $f = 30\text{MHz}$	80			MHz

CLASSIFICATION OF h_{FE}

Rank	L	H
Range	130-200	200-400

A1015 PNP Transistors

Typical Characteristics

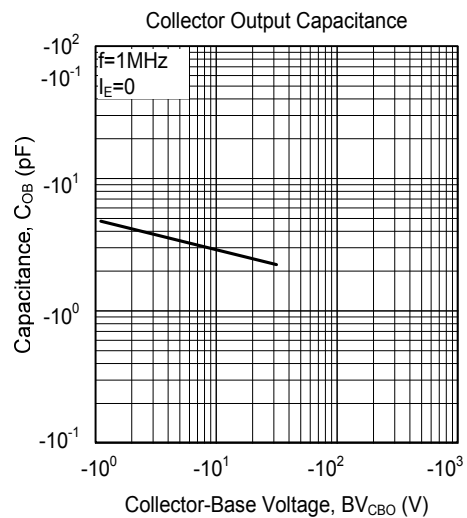
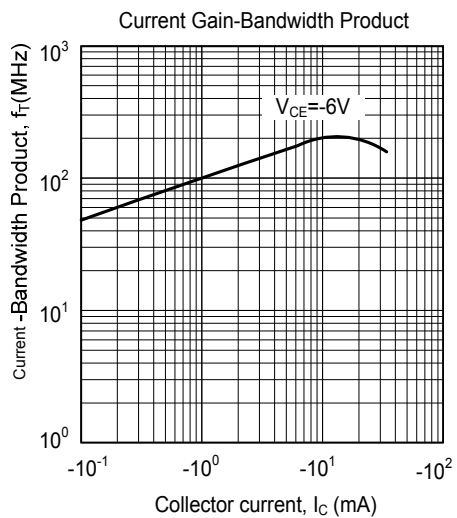
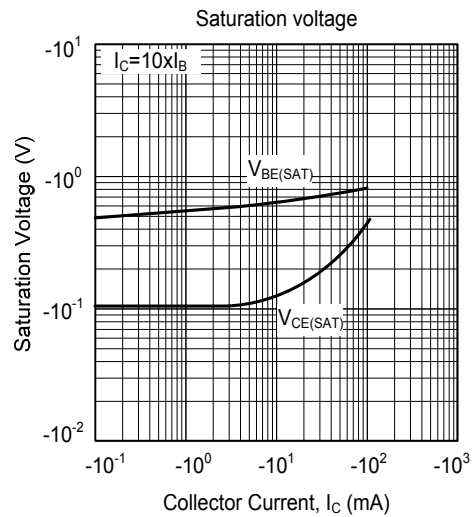
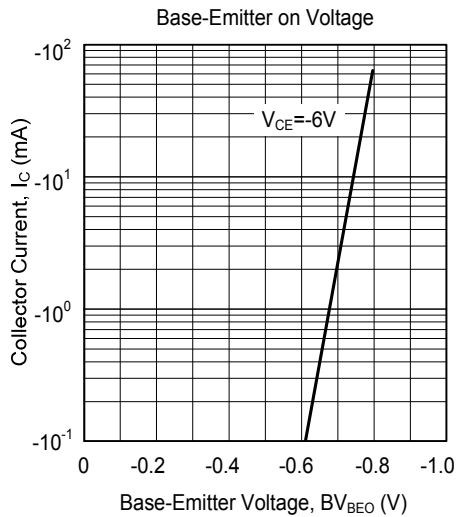
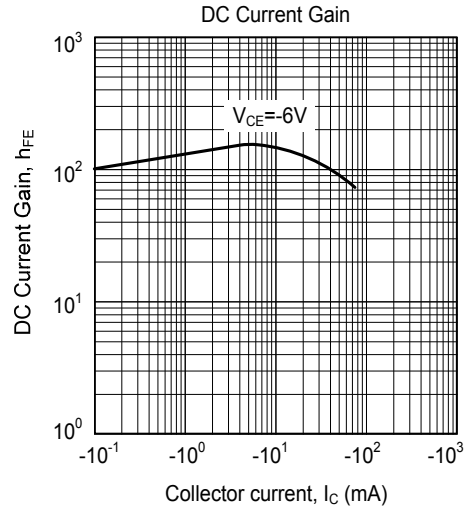
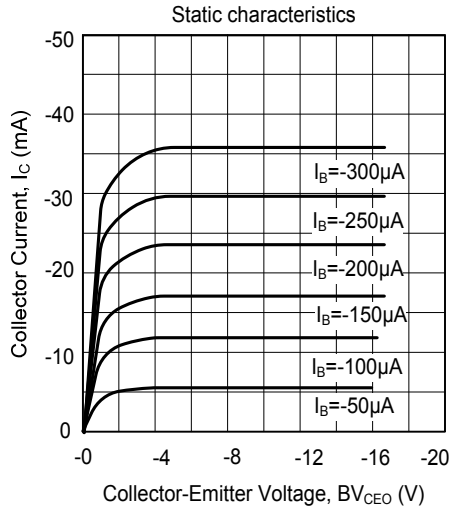

SOT-23 Package Outline Dimensions



Symbol	Dimensions In Millimeters		Dimensions In Inches	
	Min	Max	Min	Max
A	0.900	1.150	0.035	0.045
A1	0.000	0.100	0.000	0.004
A2	0.900	1.050	0.035	0.041
b	0.300	0.500	0.012	0.020
c	0.080	0.150	0.003	0.006
D	2.800	3.000	0.110	0.118
E	1.200	1.400	0.047	0.055
E1	2.250	2.550	0.089	0.100
e	0.950 TYP		0.037 TYP	
e1	1.800	2.000	0.071	0.079
L	0.550 REF		0.022 REF	
L1	0.300	0.500	0.012	0.020
θ	0°	8°	0°	8°

SOT-23 Suggested Pad Layout



Note:

1. Controlling dimension: in millimeters.
2. General tolerance: $\pm 0.05\text{mm}$.
3. The pad layout is for reference purposes only.