

isc N-Channel MOSFET Transistor

IXFN130N30

FEATURES

- Drain Current : $I_D=130A@ T_C=25^\circ C$
- Drain Source Voltage
: $V_{DSS}= 300V(\text{Min})$
- Static Drain-Source On-Resistance
: $R_{DS(\text{on})} = 18m\ \Omega (\text{TYP}) @ V_{GS}= 10V$
- 100% avalanche tested
- Minimum Lot-to-Lot variations for robust device performance and reliable operation

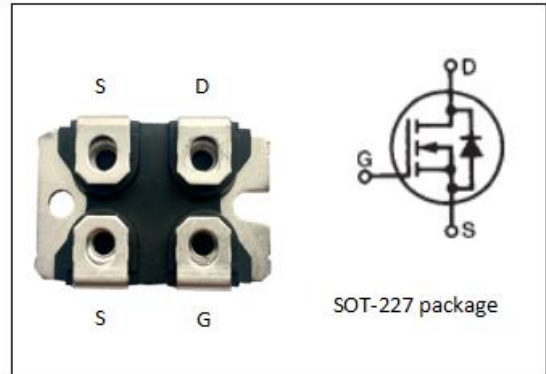

DESCRIPTION

- motor drive, DC-DC converter, power switch and solenoid drive.

ABSOLUTE MAXIMUM RATINGS($T_a=25^\circ C$)

| SYMBOL | PARAMETER | VALUE | UNIT |
|-----------|--------------------------------------|----------|------------|
| V_{DSS} | Drain-Source Voltage | 300 | V |
| V_{GS} | Gate-Source Voltage | ± 20 | V |
| I_D | Drain Current-Continuous | 130 | A |
| I_{DM} | Drain Current-Single Pulsed | 520 | A |
| P_D | Total Dissipation @ $T_C=25^\circ C$ | 700 | W |
| T_j | Max. Operating Junction Temperature | 150 | $^\circ C$ |
| T_{stg} | Storage Temperature | -55~150 | $^\circ C$ |

THERMAL CHARACTERISTICS

| SYMBOL | PARAMETER | MAX | UNIT |
|---------------|-------------------------------------|------|--------------|
| $R_{th(J-c)}$ | Junction-to-case thermal resistance | 0.18 | $^\circ C/W$ |

isc N-Channel MOSFET Transistor
IXFN130N30
ELECTRICAL CHARACTERISTICS

 T_c=25°C unless otherwise specified

| SYMBOL | PARAMETER | CONDITIONS | MIN | TYP | MAX | UNIT |
|---------------------|--------------------------------|---|-----|-----|------|------|
| BV _{DSS} | Drain-Source Breakdown Voltage | V _{GS} =0V; I _D =0.25mA | 300 | | | V |
| V _{GS(th)} | Gate Threshold Voltage | V _{DS} =V _{GS} ; I _D =0.25mA | 2.0 | | 4.0 | V |
| R _{DS(on)} | Drain-Source On-Resistance | V _{GS} =10V; I _D =65A | | 18 | 25 | mΩ |
| I _{GSS} | Gate-Source Leakage Current | V _{GS} =±20V | | | ±200 | nA |
| I _{DSS} | Drain-Source Leakage Current | V _{DS} = 300V; V _{GS} = 0V | | | 100 | μA |
| V _{SD} | Diode forward voltage | I _S = 100A, V _{GS} = 0V | | | 1.2 | V |

PACKAGE OUTLINE

Dimensions in mm

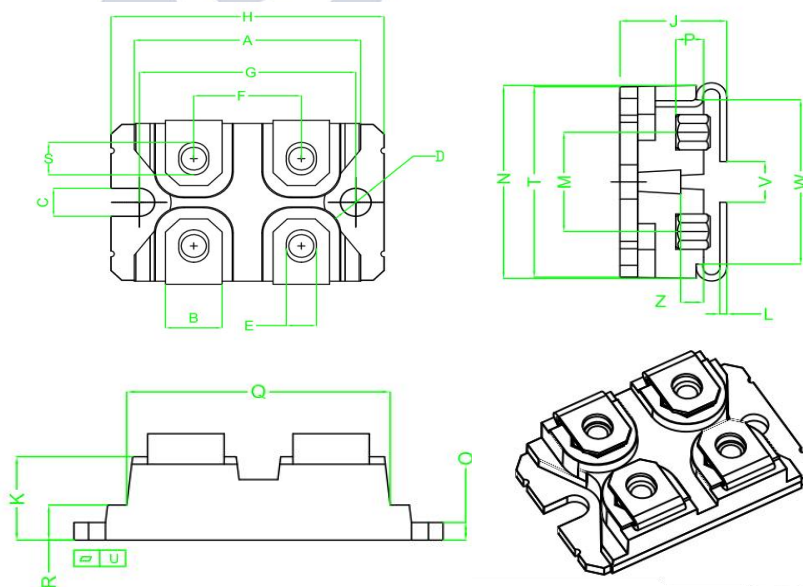

| DIM | Millimeter | |
|-----|------------|-------|
| | min | max |
| A | 31.40 | 31.60 |
| B | 7.70 | 8.10 |
| C | 4.20 | 4.40 |
| D | 4.20 | 4.40 |
| E | 4.10 | 4.40 |
| F | 14.90 | 15.10 |
| G | 30.10 | 30.30 |
| H | 38.00 | 38.40 |
| J | 12.00 | 12.60 |
| K | 9.35 | 9.65 |
| L | 0.74 | 0.84 |
| M | 12.30 | 12.70 |
| N | 24.40 | 25.00 |
| O | 1.90 | 2.10 |
| P | 2.92 | 3.32 |
| Q | 26.60 | 27.00 |
| R | 3.80 | 4.20 |
| S | 4.95 | 5.45 |
| T | 23.70 | 24.30 |
| U | 0 | 0.10 |
| V | 3.50 | 5.50 |
| W | 20.15 | 20.45 |
| Z | 2.50 | 2.70 |

isc N-Channel MOSFET Transistor**IXFN130N30**

NOTICE:

ISC reserves the rights to make changes of the content herein the datasheet at any time without notification. The information contained herein is presented only as a guide for the applications of our products.

ISC products are intended for usage in general electronic equipment. The products are not designed for use in equipment which require specialized quality and/or reliability, or in equipment which could have applications in hazardous environments, aerospace industry, or medical field. Please contact us if you intend our products to be used in these special applications.

ISC makes no warranty or guarantee regarding the suitability of its products for any particular purpose, nor does ISC assume any liability arising from the application or use of any products, and specifically disclaims any and all liability, including without limitation special, consequential or incidental damages.